

ANALYSIS OF TWO DESIGN KIND OF PROPULSION FOR AN INLAND VESSEL

Czesław Dymarski

Gdańsk University of Technology
ul. G. Narutowicza 11/12, 80-952 Gdańsk, Poland
tel.: (58) 347 16 08, fax: (58) 34147 12
e-mail: cpdymars@pg.gda.pl

Abstract

This paper presents design assumptions, technical conditions and two kinds of design solution of propulsion system for an inland waterways ship. In the first version this is a combustion-electric system fitted with frequency converter and in the other - combustion-hydraulic one with hydrostatic reduction gear. There are also a preliminary comparative analysis of these systems.

Keywords: *ship propulsion systems, combustion-electric driving system, combustion-hydraulic driving system*

1. Introduction

Accede Poland to the European Union created significant increase of interest of an inland sailing especially in an east-west direction. A good example of this interest, not only our country but also European authorities, is assign some financial outlays on realization research works in European project EURECA.

One of such projects, realized mainly at Gdansk University of Technology, the Faculty of Ocean Engineering and Ship Technology, is project INCOWATRANS E!3065. The project concerns designing of passenger inland waterways ships intended for sailing on a shipping route Berlin – Torun – Kaliningrad. Acquaintance with rout of navigation is in case of inland waterways ship very essential. Construction of such ships and their propulsion systems depend on depth of the water routes, and dimensions of the existing thereon sluices, and also on different conditioning, in this also ecological.

One of the basic ship systems, which have decisive meaning for effectiveness and safety of navigation is propulsion and steering system. Several kinds of propulsion systems are applied on board modern inland waterways ships, out of which the following can be enumerated :

- conventional one fitted with a combustion engine, toothed gear and fixed or controllable pitch propeller, free or ducted in a fixed or pivot able Kort's nozzle
- combustion-electric one fitted with an electric transmission and frequency converter making it possible to steplessly control rotational speed of the propeller which may be fixed one
- combustion-hydraulic one fitted with a hydrostatic transmission and fixed propeller
- propulsion system fitted with two azimuthal propellers (rotatable thrusters) driven by combustion engines through a toothed, electric or hydrostatic transmission
- propulsion system fitted with cycloidal (Yoith- Schneider) propellers
- propulsion system fitted with water jet propellers.

Below are presented basic design assumptions and two selected design concepts of propulsion system for the mentioned ship.

2. Basic design assumption and choice of propulsion system

In this case the main external conditioning having of the principle influence on the basic projects - foundations of ship, resulted due to technical – exploitation features of the foreseen route of navigation. Some the most important of them are as follow:

- minimum depth of the water route - 1,2 m
- length of the shortest sluices - ~60 m
- minimum clearance of the bridge on the route - 3,87 m
- high ecological requirements

Taking into consideration above-mentioned conditioning worked out general concept design of the ship. Assumed that the ship would consist of two connected segments: pusher and hotel barge, which can be seen in Fig.1.

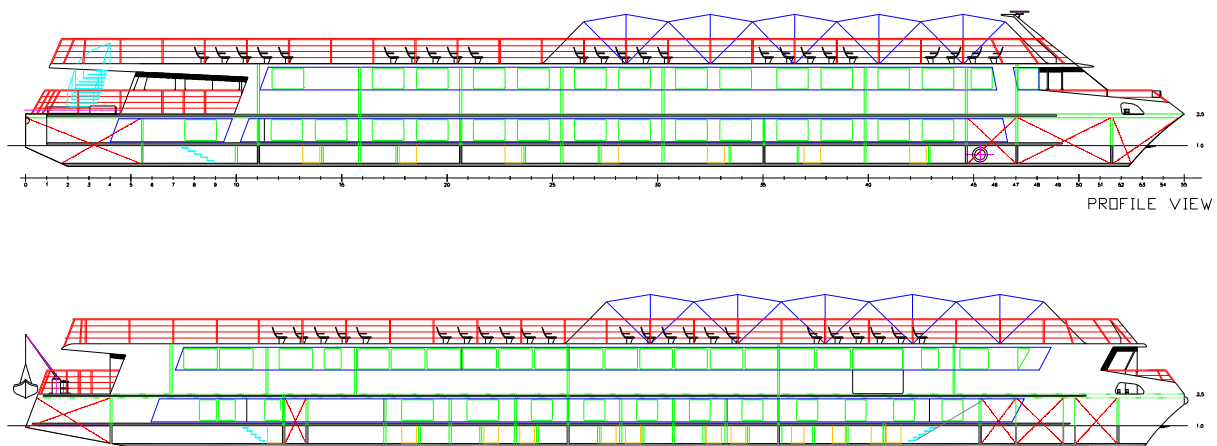

Fig. 1. View of the two segments of the designed inland ship: hotel barge – upper drawing and pusher – lower drawing

The basic technical parameters are as follow:

- | | | |
|--------------------------------------|-------------------|----------------------------|
| - overall length of the each segment | | $L = 56 \text{ m}$ |
| - overall breadth | | $B = 9 \text{ m,}$ |
| - draught | | $T = 1 \text{ m,}$ |
| - ship displacement for | $T = 1 \text{ m}$ | $D_{1.0} = 440 \text{ t,}$ |
| - expected velocity for | $T = 1 \text{ m}$ | $V = 14 \text{ km/h,}$ |
| - required power output | | $P = 300 \text{ kW.}$ |

The required very small draught of the ship is an important limitation in searching for a suitable propulsion system. Certainly it cannot be a propulsion system using cycloidal propellers which are located under the ship's hull. Ships driven by water jets fairly well operate in shallow waters. However such drive is unfavourable from the ecological point of view. A large water stream sucked out from under ship's bottom and thrown overboard with a great velocity destroys bottom and side structures of the waterway and biological live existing there. In this case the factor has been deemed so important that it was decided to exclude the water jet propulsion system from further considerations.

Hence only the systems fitted with screw propellers have been taken into account. As the propeller is assumed to operate in non-cavitating range, its appropriate diameter should be greater than 1.4 m. In the case of two propellers used e.g. in Schottel rotatable thrusters the diameter of each of them might be a little smaller, equal to about 1.35 m.

Due to the small draught of the ship the above mentioned values of propeller diameter are not acceptable.

Therefore it was deemed necessary to apply a double-propeller propulsion system. This way it would be possible to decrease the diameter of the propellers to such an extent as to decrease its value to 0.83 - 0.85 m in the case of placing them in Korfs nozzles, being still large enough to transfer the assumed power. The outer diameter of the nozzles would then exceed a little the draught of 1 m, but if ship's hull form is suitably corrected it will not be a problem. Such solution has many advantages. The double-propeller propulsion system provides higher ship's manoeuvrability and reliability. Location of the propellers inside the nozzles significantly lowers risk of catching the propeller's blade on the bottom that usually results in a failure and necessity of replacement of the propeller. Ducting the propellers also lowers unfavourable influence of screw race on the waterway bottom structure.

An additional improvement of reliability of the system and its simplification can be obtained by applying the fixed-pitch propeller. However it requires to provide the system with capability of changing magnitude and direction of rotational speed of the propeller shaft, that can be realized in the simplest way by a hydrostatic or electric transmission included in the propulsion system.

Further advantages can be achieved by replacing the fixed nozzle with pivotable one, and even better by using a rotatable thruster. This makes it possible to resign from applying the traditional rudder and in consequence to significantly decrease gabarites and weight of the device and simultaneously to improve ship's manoeuvrability.

Taking into account the above presented factors one decided to elaborate conceptual design projects of two solutions of the propulsion system fitted with rotatable thrusters, the most technically justified in the opinion of these authors, namely :

- combustion-electric one fitted with typical asynchronous squirrel-cage electric motors and frequency converters making stepless control of rotational speed of fixed propeller possible
- combustion-hydraulic one fitted with hydrostatic transmission.

3. Combustion-electric propulsion system

The elaborated combustion-electric main propulsion system of the ship is shown as a diagram in Fig.2.

Three electric generating sets were applied; each of them consisted of a four-stroke combustion engine driving a three-phase synchronous generator. The total power output of the three generating sets fully covers power demand for propelling and steering the ship. The output of the third generating set suffices to cover the assumed power demand of other consumers. So produced energy is delivered to the main switchboard. From here its main part goes to the frequency converters and next to the three-phase asynchronous electric motors driving the fixed screw propellers through the toothed intersecting-axis gear.

The ship steering functions are realized by rotating the column of rotatable thruster by an arbitrary angle around the vertical axis. To this end were used two hydraulic motors of a constant absorbing capacity, driving the column through toothed gears. The motors are fed from a constant capacity pump placed in the oil tank system, which is seen in Fig. 3. showing, in two axonometric projections, an arrangement of the main components of the presented system.

In this version of the system have been applied the electric motors in vertical position, that made it possible to obtain a modular construction of rotatable thruster, more compact and having relatively small gabarites. The drive is transmitted from the motors to the propeller shaft through the one-stage toothed gear placed inside the pod (electric podded propulsor) of rotatable thruster under water. Its reduction ratio is small because of a limited size of the pod, that makes it necessary to use a four-pole medium-speed electric motor.

A drawback of the solution is that the upper surface of the electric motor sticks out a little over the first deck of the ship (not shown in the figure). Another unfavourable feature is that the mass centre of electric motors is located high and shifted aft.

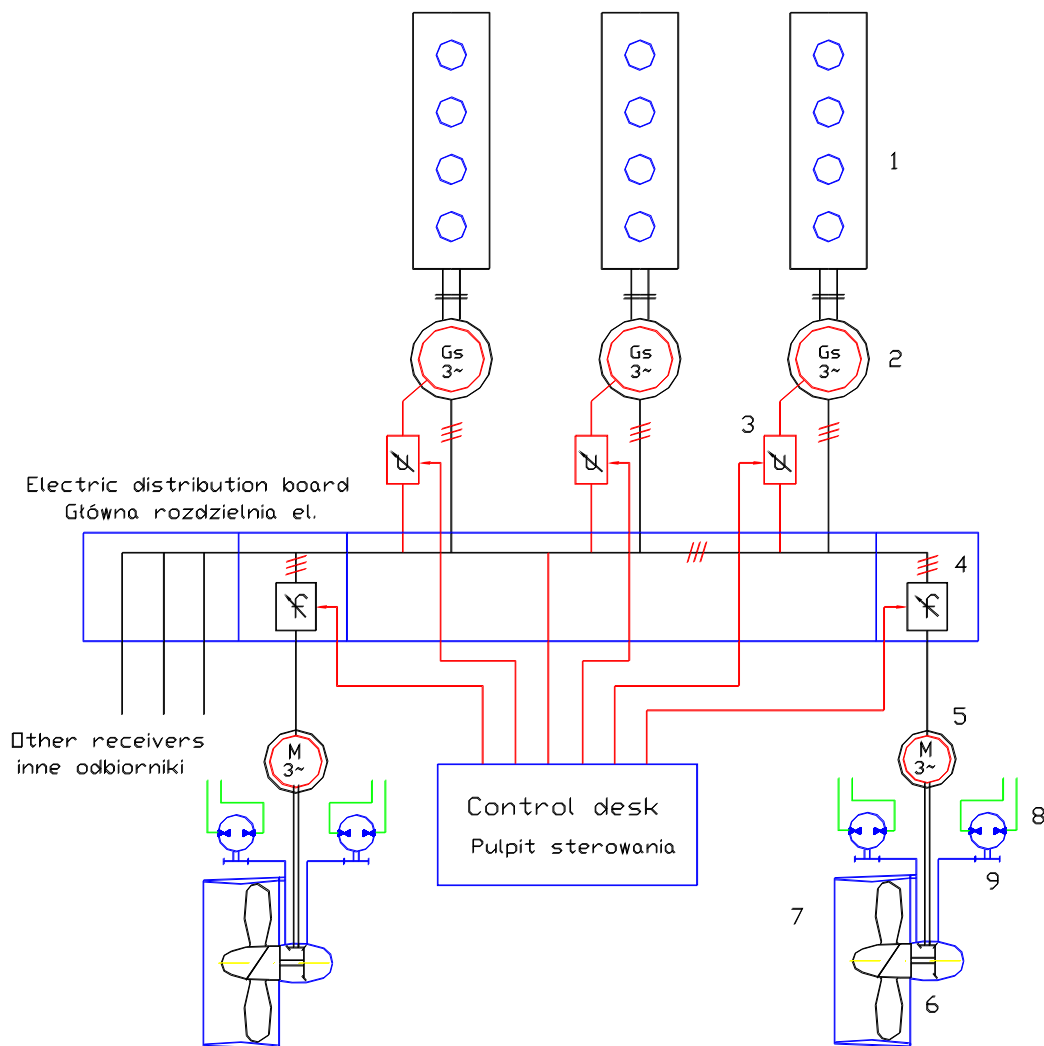
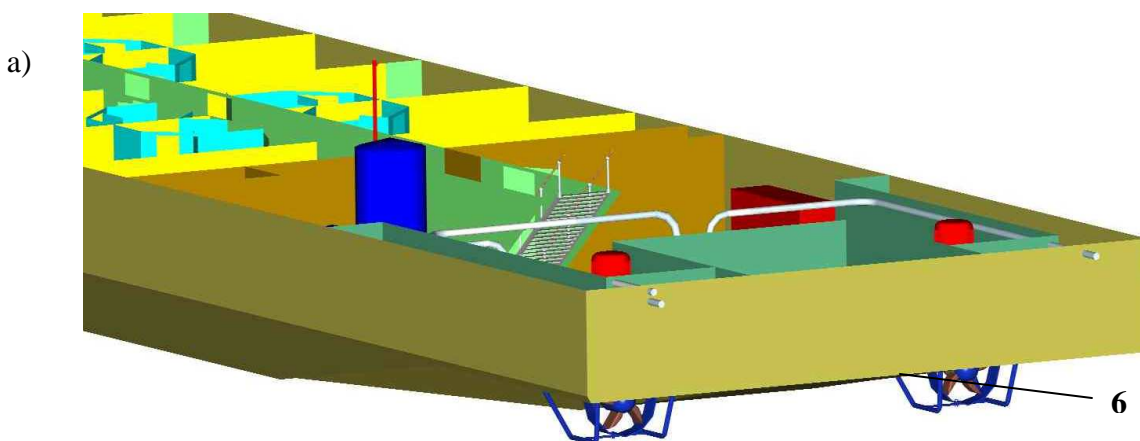

Fig. 2. Simplified schematic diagram of the combustion-electric main propulsion system of the ship. Notation: 1 – combustion engine, 2 – electric generator, auxiliary electric generating set, 3 – regulator of induced voltage of the electric generator, 4 – frequency converter, 5 – electric three-phase asynchronous cage motor, 6 – toothed intersecting-axis gear, 7 – fixed pitch propeller, 8 – hydraulic motors



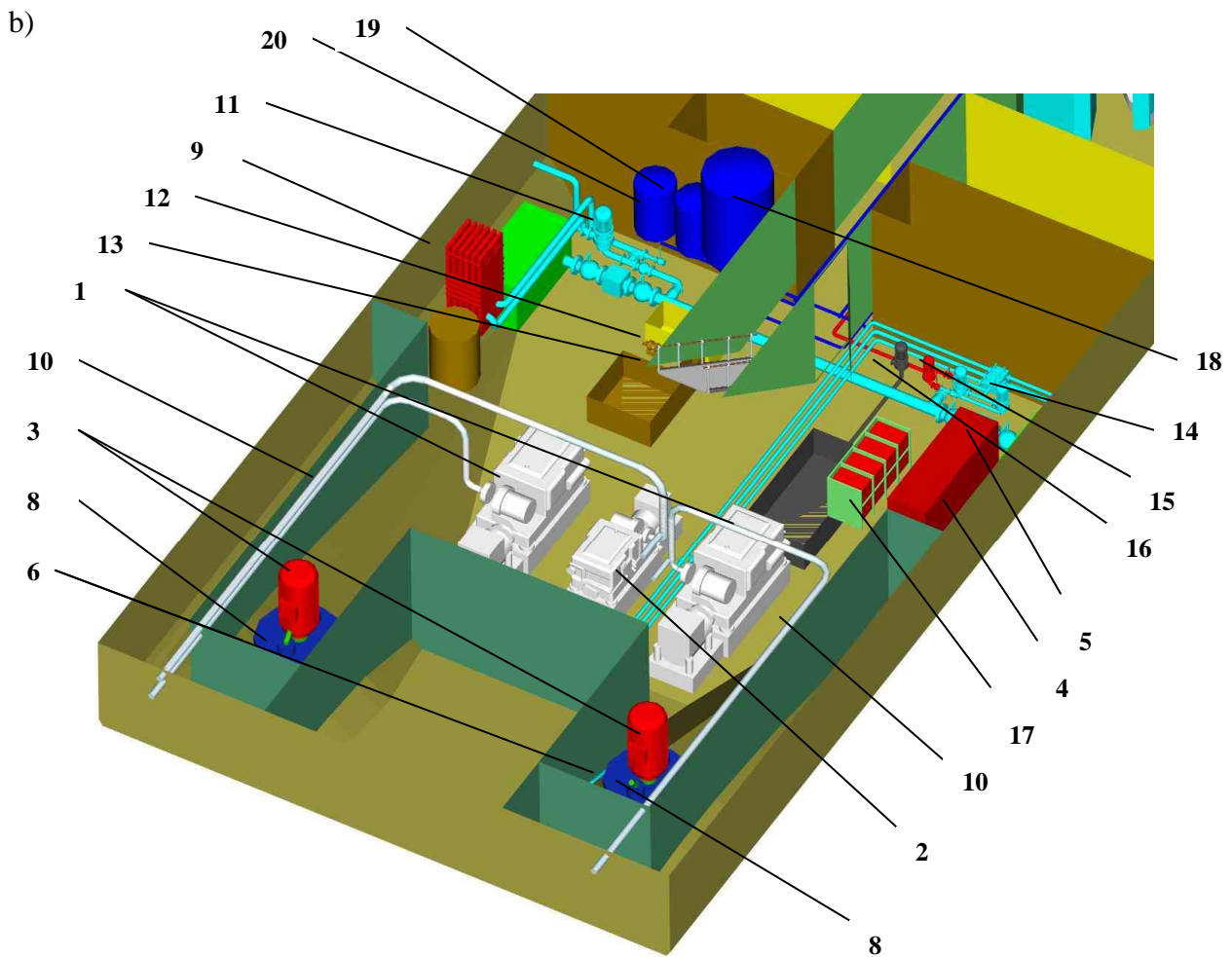

Fig.3. View of an example arrangement of the main components of the combustion-electric propulsion system.
 Notation : 1 - electric generating set, 2 - auxiliary electric generating set, 3 - driving the propeller, 4 -frequency converter, 5 - main switchboard, 6 rotatable thruster, 7 - hydraulic unit for supplying hydraulic motors, 8 - hydraulic motor fitted with planetary gear to drive the mechanism rotating the column of rotatable thruster, 9 - central " outboard water - fresh water " cooler, 10-exhaust piping with silencers, 11 - outboard water pump, 12 - lubricating oil pump and tank, 13 - fuel tank and pump, 14 - ballast pump, 15 - bilge pump, 16 - fire pump, 17 - accumulator, 18 - hydrophore tank, 19 - electric water heater, 20 - water heater

4. Combustion-hydraulic propulsion system

Fig.4 shows schematic diagram of the propulsion system fitted with hydrostatic transmission.

The system is composed of two identical, mutually independent subsystems; each of them is driven by a high-speed combustion engine I. The engine, through a flexible coupling II, directly drives : an unit of two oil pumps 2 and 3, and also, through a mechanical gear III, an electric generator and a pump 4. The pump of variable capacity 3 and the pump of constant capacity 2 together with control unit V are the main source of energetic oil for feeding a fixed displacement hydraulic motor 11. The motor drives, through a toothed bevel gear, a fixed propeller located within a nozzle of a rotatable thruster XIV. In this case the application of a fixed propeller was justified by making it possible to steplessly control speed and direction of rotation of the hydraulic motor 11. This is realized by changing the capacity of the main pump 3 and oil pumping direction with the help of the servomechanism of the pump.

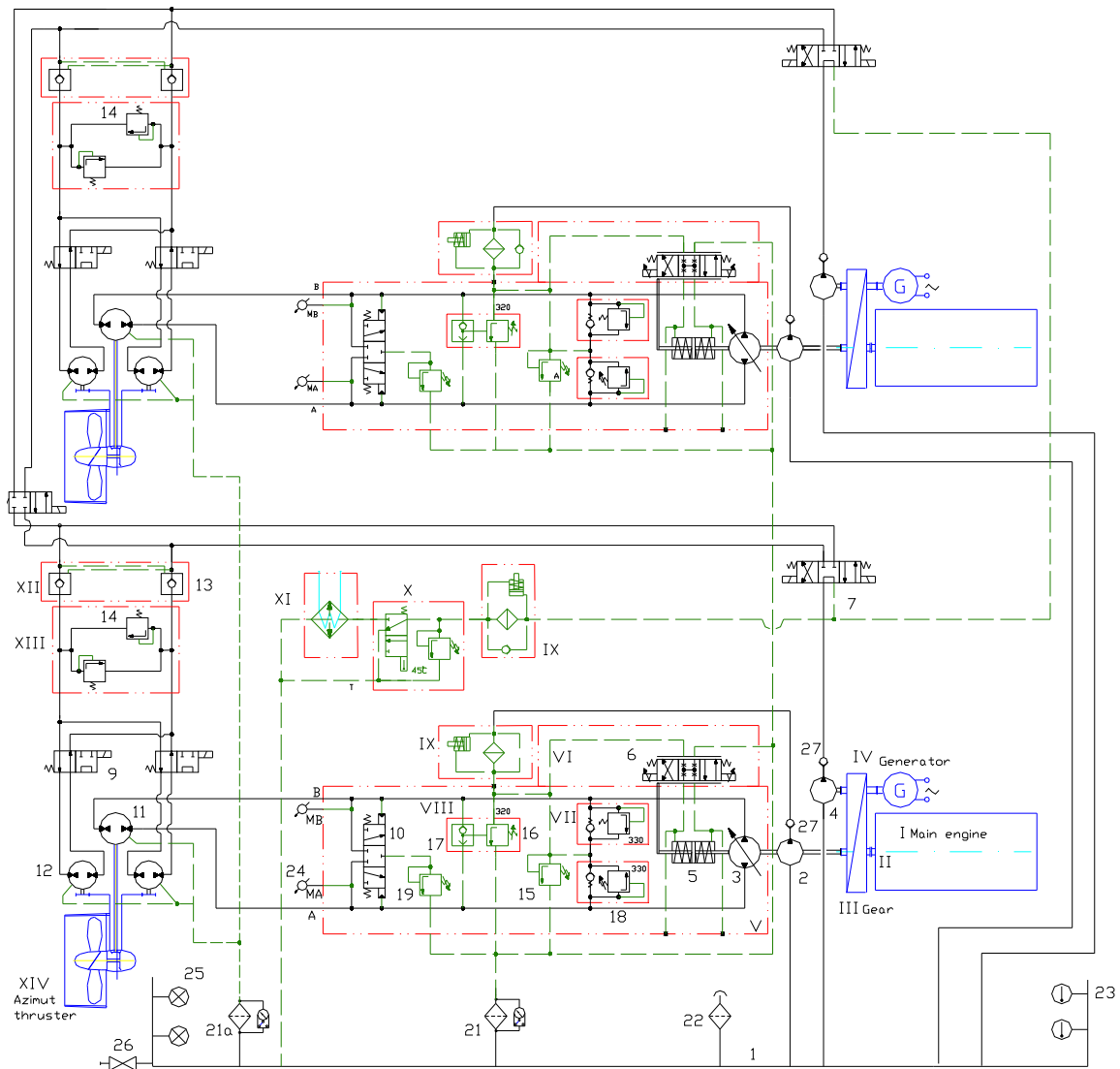

Fig. 4. Schematic diagram of the combustion-hydraulic propulsion system.

The servomechanism consist of a hydraulic cylinder 5 and a proportional valve 6 which is fed from the small pump 2 installed at the main pump 3.

The oil from the pump 2 flows through a check valves 27 to a filter in block IX and next divides into four branches:

- ◆ feeding the proportional valve 6 - block VI,
- ◆ feeding through one of two check valve a low-pressure line of the pump 3 - blocks VII,
- ◆ feeding a pressure relief valves 15,
- ◆ feeding a pilot operated relief valves 16 – block VIII,

During normal work cool and clear oil supplied from the pump 2 flows through one of two check valves in block VII into the actually low-pressure line of the main pump 3. Simultaneously from this line the same quantity of the hot oil have to be taken off. The oil flows off through a 3/3-way directional control valves 10, a pressure relief valves 19 and return filter 21 to an oil tank 1. The valve 10 is controlled by higher pressure of the both lines of the main pump 3, and always connects the low-pressure line with the pressure relief valves 19, which opening pressure value is set up a little lower than for the pressure relief valves 15.

A pressure relief valves 18 fulfill duty of safety valves and protect the both lines of the main pump 3 against excess in increasing of the oil's pressure.

As it was mentioned earlier, each propeller is driven by the hydraulic motor 11 through the reduction conical gear localized inside a pod. The hydraulic motor is placed in vertical position inside the vessel's hull directly above the azimuth thruster. A shaft of the hydraulic motor is coupled with a shaft of the conical gear.

Steering of the vessel is realized by turning of the thruster round vertical axe. A thruster's column is driven by two 2-directional fixed displacement hydraulic motors 12 through the reduction gear. The hydraulic motors 12 are fed by fixed displacement oil pump 4. Both lines feeding these hydraulic motors are equipped with pilot operated check valves 13 (block XI) and pressure relief valves 14 (block XII). The valves 13 protect the column with nozzle against unintentional turning caused by external hydrodynamic forces, and the pressure relief valves – against overloading mechanism in case of striking the nozzle against the bottom.

Use of two hydraulic motors and the reduction gear was dictated mainly by aim to decrease their dimensions for enable to locate all three hydraulic motors in one plane for well-chosen coronary bearing of a vertical column of the azimuth thruster. Two smaller motors make possible, as in symmetrical arrangement, to reduce the weights considerably and the same the dimensions of the toothed gear. The motors 12 are fed in parallel arrangement through 4/2-way directional control valves 9, controlled electromagnetically. This enables to cut hydraulically off from feeding of any motor with simultaneous connection both hydraulic lines of the motor. In this way the thruster column can be driven by one motor only, when the second motor is working as a pump on overflow with insignificant losses of the power. It should be marked, that possible to obtainment torque would be a little less than a half of the nominal torque. However, during normal navigation on longer distances, it seems to be sufficient for control the course of the ship.

Considering, that the time of manoeuvres with turning of the azimuth thruster is relatively very short in comparison with the total time of navigation, this subsystem is used also for cleaning and a cooling oil in the reservoir 1. In periods between manoeuvres a 4/3-way directional control valve 7 is in central-position, cutting hydraulically off feeding of the motors 12 and direct the whole delivery of the pump 4 to block IX - filtration of the oil, block X - control of temperature and alternatively to block XI - cooling of the oil, and in the end to the reservoir 1. Both subsystems for drive turning mechanisms of the thrusters can be connect by means of electromagnetically controlled 4/2-way directional control valves 8. It makes possible turning both thrusters during work only by one main engine also.

Oil tank 1 is common for both main subsystems and is equipped with inlet filter 22, temperature detectors 23, sensors of oil level 25 and a manual operated shut-off valve 26, enabling draining of oil from the reservoir 1. The leakages of oil from hydraulic motors are collected in drain line and are led through a return filter 21 to the oil tank 1.

An arrangement of the main components of the system is presented in axonometric projection in Fig. 5. There are seen an electric switchboard an electric generating set which was applied to satisfy electric energy demand of other consumers.

The system was provided with one oil tank and central "outboard water - fresh water" cooler (12) that made it possible to reduce space of the ship power plant as well as a number of its auxiliary devices.

5. Comparative analysis of the systems

Final choice of the most favourable system is not an easy task as it must take into account a broad range of various factors including first of all: manoeuvrability, reliability, initial and operational costs, as well as area and space occupied by the system, its mass, location of its centre of gravity etc.

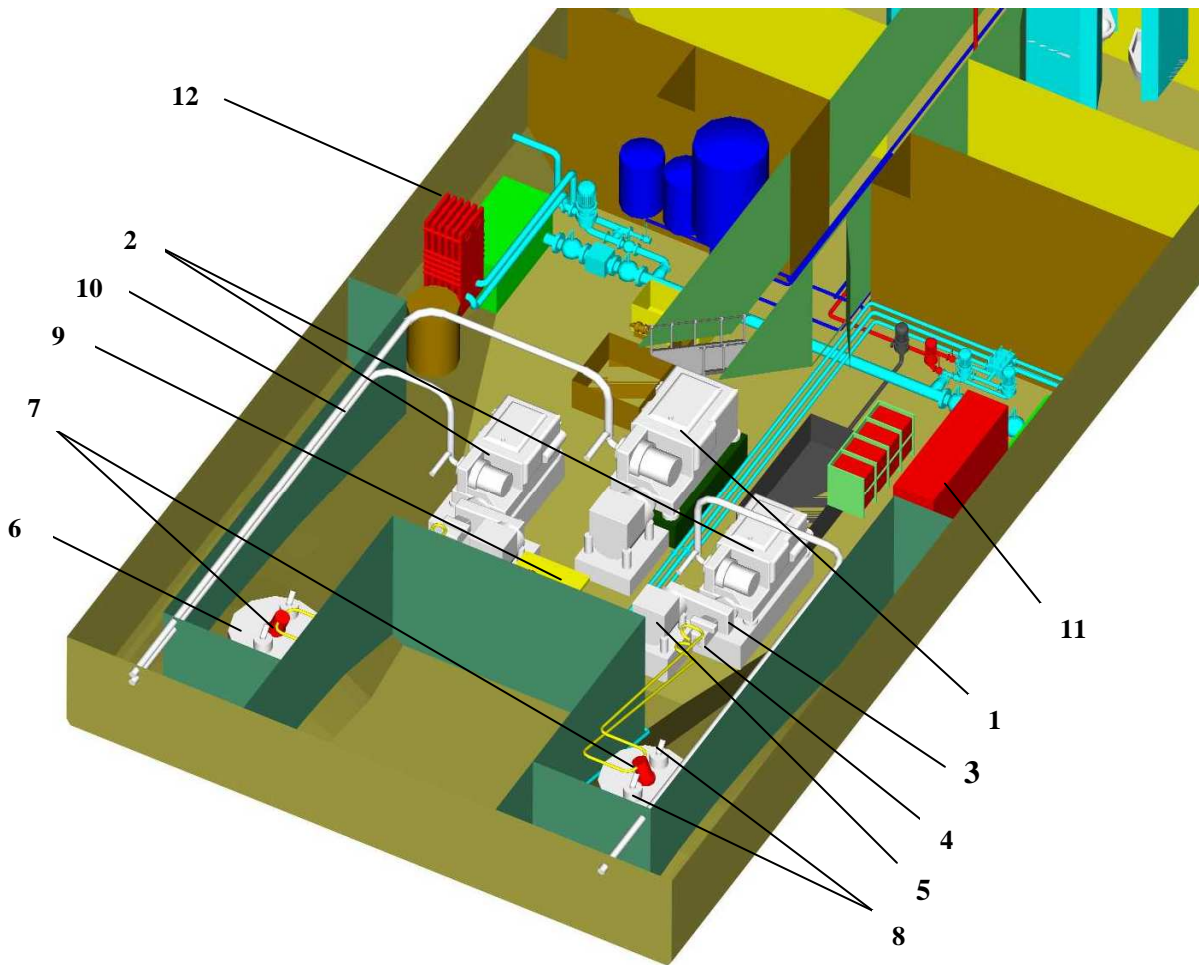

Fig. 5. View of an example arrangement of the main components of the combustion-hydraulic propulsion system. Notation: 1 – electric generating set, 2 - combustion engine, 3 - mechanical gear, 4 – the main pump unit to drive the propeller, 5 - electric generator, 6 - rotatable thruster, 7 - hydraulic motor driving the propeller, 8 - hydraulic motors to rotate the rotatable thruster around vertical axis, 9 – hydraulic oil supplying unit, 10 - exhaust piping with silencers, 11 – electric switchboard, 12 - central " outboard water - fresh water " cooler

In Tab. 1 - 2 and diagrams (Fig.6) are presented some important data concerning the features and costs of the considered propulsion systems, which are supposed to make decision-taking easier.

Tabela 1. Parameters and prices (costs) of the units of the combustion-electric propulsion system

Name o unit	Gabarities	Number	Mass: of one unit /total [kg]	Volume [m ³] / area [m ²]	Gross price: of one unit / total [EURO]
Electric generating set of 240 kW output IVECO GE 8210SRM45	2737x1150x1371	2	2820 / 5640	8.63 / 6.30	57050 / 114100
Electric generating set of 112 kW output IVECO GE 8361SRM32	2309x720x1280	1	1950 / 1950	2.13 / 1.66	37100 / 37100
Electric motors of 200 kW power EMIT SVgm 315 mL4	1210x600x800	2	1120 / 2240	1.16 / 0.96 not accounted for in calculations*	6500 / 13000

Frequency converter Danfoss VLT	370x420x1600	2	200 / 400	0,50 / 0.31	18000 / 36000
Hydraulic oil tank unit	500x500x700	1	300 / 300	0,15 / 0,25	
Azimuth thruster		2	910 / 1820		54000 / 108000
Total			/12350	11.41 / 8,52	/~308200

Tabela 2. Parametry i ceny zespołów systemu Diesel-hydraulicznego z przekładnią hydrostatyczną

Name o unit	Gabarities	Number	Masa: jednostkowa / łączna [kg]	Objętość [m ³] / powierzchnia [m ²]	Cena: jednostkowa / łączna [EURO]
Combustion engine of 220 kW IVECO CURSOR 300	1770x935x1030	2	900 / 1800	3,41 / 3.31	24500 / 49000
Electric generating set of 160 kW output IVECO GE8210SRM36	2975x1110x1940	1	2520 / 2520	6.41 / 3.30	47160 / 47160
Hydraulic pump of 252 kW max. output Rexroth A4VSG 180	350x300x220	2	114 / 228	0,05 / 0.21	12000 / 24000
Hydraulic motor of 220 kW max. output Rexroth A2FM 250	224x280x250	2	73 / 146	0,03 / 0.13 not enter for in calculations*	5368 / 10736
Electric generator of 40kW output Leroy – Somer 2.2VL8	615x450x450	2	165 / 330	0,25 / 0.55	3000 / 6000
Hydraulic oil tank unit	1000x1000x1300	1	1050 / 1050	1.23/1	
Azimuth thruster	-	2	900 / 1800	-	54000 / 108000
Total			/ 7874	11.31 / 8.37	/~244900

- This unit does not occupy any useful space of the power plant

As far as the broadly understood ship's manoeuvrability is concerned the propulsion system with hydrostatic transmission shows more advantages out of which the following are most important:

- better protection of the propulsion system against overloading that results in much higher reliability and durability of its units especially the bevel gear;
- more accurately and faster realized turns that mainly results from many times smaller inertia moments of the hydraulic motors as compared with those of electric ones.

Successive advantages of the combustion-hydraulic system are its smaller weight and gabarities. They first of all result from many times smaller mass of the hydraulic motors and space occupied by them against those of the electric motors of the same power. As results from the data included in the tables the masses differ to each other almost fifteen times. Another source of the merits is the application of the much lighter high-speed combustion engines for driving the hydraulic pumps, having rotational speed much higher than that of the electric generating sets used in the combustion-electric propulsion system. It makes advantageous location of a center of gravity shifted in direction of the ship center. The features are especially favourable in the case of small vessels especially those intended for sailing in shallow waters. Another important advantage of the system fitted with hydrostatic transmission is its smaller initial cost amounting to less than 77% of that of the remaining systems in question.

The main drawback of the considered system is its higher operational costs. They mainly result from a lower efficiency of the system. From the so far performed analyses it results that the efficiency of the combustion-electric system is by about 5% higher than that of the combustion-hydraulic system, at rated values of their operational parameters. For this reason in the combustion-hydraulic system a somewhat higher total power output of combustion engines has been provided for. The need of periodical change of oil and filtering cartridges additionally rises operational costs.

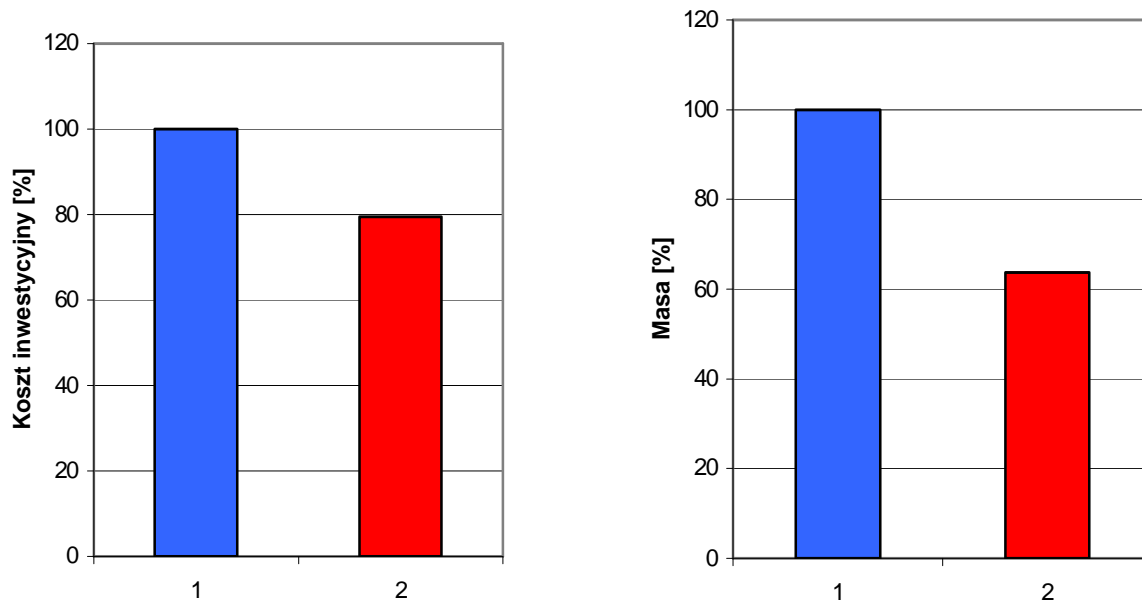

Fig. 6. Comparison of initial costs and mass of the both presented propulsion systems:
1 – Combustion-electric one, 2 – Combustion-hydraulic one

6. Final remarks

The both presented design variants of the ship propulsion systems satisfy the assumptions enumerated in introduction and each of them could be applied to the designed ship. To choose the most favourable one out them is not an easy task. However the author are convinced that the above presented analysis of basic features and costs of each of the systems certainly may help the principal designer of the ship in making a proper choice.

Bibliography

- [1] Dymarski Cz., Skorek G., *Energy balance of conceptual design of propulsion system with hydrostatic transmission for inland and coastal vessel (in Polish)*. Faculty of Ocean Eng. and Ship Techn., Gdansk University of Technology. Research Report No 154/E/2004.
- [2] Dymarski Cz., Rolbiecki R.: *Conceptual design of propulsion and control system with hydrostatic transmission for inland vessel (in Polish)*. Faculty of Ocean Eng. and Ship Techn., Gdansk University of Technology. Research Report No 164/E/2004.
- [3] Dymarski Cz., *An azimuthing combustion-hydraulic propulsion system for inland vessel*, Marine Technology Transaction (Technika Morska), Vol. 16, 2005.
- [4] Information pamphlets and offer materials of the following companies: KaMeWa, Lips, Schottel, Ulstein, Wartsila, Iveco Motors, Bosch Rexroth, Emit, Lcroy - Some.

