

Daniel KOWALAK, Roman PARTYKA, Andrzej WOLNY

GDANSK UNIVERSITY OF TECHNOLOGY, FACULTY OF ELECTRICAL AND CONTROL ENGINEERING

Discrete measurement of fault-arc velocity

M.Sc. Daniel KOWALAK

Was born in 1981 in Reszel, Poland. He received M.Sc. degree from the Gdansk University of Technology in 2006. At present, he is a researcher at the Gdansk University of Technology, High Voltages and Electrical Apparatus. He is interested in fault-arcs and power engineering.



e-mail: d.kowalak@ely.pg.gda.pl

Ph.D. Roman PARTYKA

He received his M.Sc. (1972) and Ph.D. (1987) degrees in Electrical Engineering from the Gdańsk University of Technology. At present he is researcher at the Gdańsk University of Technology, High Voltages and Electrical Apparatus. His area of interest is power engineering, particularly the fault arc in switchboards.



e-mail: r.partyka@ely.pg.gda.pl

Prof. Andrzej WOLNY

Was born in 1939 in Warsaw, Poland. He received M.Sc., Ph.D. and D.Sc. degrees from the Electrical Engineering Faculty of the Gdansk University of Technology in 1961, 1974 and 1995 respectively, and in 2001 was granted the title professor. He is the author of a monography on "Fuse-to varistor current commutation", and the book on "Current breaking through commutation". His scientific activity focuses on problems of electrical apparatuses and the high voltages techniques.



e-mail: awolny@ely.pg.gda.pl

Abstract

The discrete method of measurement of the single-phase fault-arc velocity has been described. A flat, horizontal arrangement of bus-bars was applied. The investigations were conducted with the help of optical sensors evenly arranged along the bus-bars. Description of the test set-up, its characteristics, the influence of dimensions of the ionised area on the measurement results have been presented, as well as some examples of the arc velocity variations.

Keywords: fault-arc, arc velocity, optoelectronic measurement of velocity.

Dyskretny pomiar prędkości łuku awaryjnego

Streszczenie

Opisano metodę dyskretnego pomiaru prędkości jednofazowego łuku awaryjnego poruszającego się w płaskim, poziomym układzie szyn. Badania przeprowadzono za pomocą punktowych czujników optycznych rozmieszczonych równomiernie wzdłuż szyn. Podano opis układu, jego charakterystykę, wpływ obszaru zjonizowanego na uzyskiwane wyniki i zależności między obserwowanymi wielkościami.

Słowa kluczowe: łuk awaryjny, prędkość łuku, optoelektroniczny pomiar prędkości.

1. Introduction

The most of short-circuits occurring in switchgears are fault-arcs. Their movement along bus-bars facilitates air heating provoking dangerous increase in the air pressure. The knowledge on arc behaviour in the switchgear makes it easier to evaluate potential danger.

The fault-arc investigations presented in the literature [1, 3, 5] mostly relate to the average arc velocity linked to RMS value of arc current and bus-bars separation. There is little information about temporal changes of the arc motion, and the effect of external objects interfering the movement, which is important for practical switchgear design. The knowledge on the arc velocity variation facilitates a better analysis of fault-arc effects in switchgears.

One can imagine that the most exhausting information would provide high-speed photography. However the lack of distinct limits of the arc column and, in the practice, the discrete measurement of the arc velocity based on the analysis frame-by-frame the results not always have to be satisfactory. To get reliable measurement a large number of frames for analysis is needed, which demands the application of costly high-speed cameras.

Among various possible ways of the arc velocity evaluation one can distinguish the recording of light signals, associated with the moving arc column, using optical probes located in chosen points along bus-bars. It is characterised by the galvanic separation of measuring and main circuits, low electromagnetic interference, low cost, and simple design.

The lack of distinctive limits of the arc column due to the temperature distribution in the arc makes it difficult to uniquely define the arc-column position. This means that the arc column width measured in different ways is a function of features of used sensors and methods of signal formation.

In opposition to the stationary arc, the temperature profiles in the cross-section of a moving arc column are not centric. The maximum temperature point displaces in the direction of the arc movement due to the electrodynamic forces acting on the lightweight electrons. Therefore the hotter area is located in the front of the moving arc column and the cooler "tail" stays in the rear of the elongated ionised zone (Fig. 1).

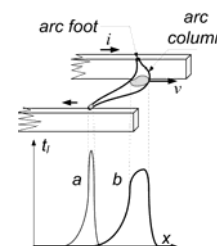

Rys. 1. Rozkład temperatury w przekroju poprzecznym przemieszczającej się kolumny łukowej: a – blisko stóp łuku, b – po środku długości kolumny

Fig. 1. Temperature distribution in the cross-section of moving arc column: a – close to the arc feet, b – in the middle of column length

Brightness of a selected area of the arc zone depends also on the distance of that area from edges of the bus-bars, since the cooling conditions change along the column. The arc feet collecting all current threads do not move smoothly. They tend to jump on a typical rough surface. On the other hand air whirls distort column shape and its movement. Therefore signals collected from different parts of the arc column display different characteristics.

2. Location of light sensors

The way the sensors are located in relation to bus-bars decides which part of the arc is observed, e.g. the arc-foot or a point of the

arc column at a chosen distance from the bus-bar, and how accurate the arc velocity can be evaluated. Selecting separations between sensors the “visible” breadth of the luminous area should be taken under consideration, which means that frequency characteristics of sensors are important. Used sensors and detectors sensitive to high frequency radiation, cooler parts of the luminous zone become invisible. The arc column seems to be narrower, so the distances between sensors can be reduced. It is worth noticing that an uniform distribution of sensors need not assure the best record resolution, because both the arc velocity and the width of luminous area follow the current variation. The arc velocity, and therefore the sensors separation is also influenced by the geometry of bus-bars arrangement, their material, state of their surface, and the separation between them. However, the consideration of all these factors would only be possible, if the variability of speed along busway would be known in advance. Therefore, constant separations between sensors were used in experiments, Fig. 2. Only the effect of test currents settings was considered.

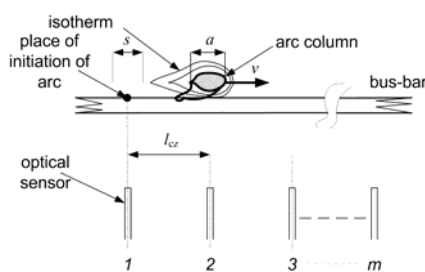

Rys. 2. Czynniki oddziałujące na pomiar prędkości łuku: a – „rozpoznawalna” strefa świecąca łuku, s – obszar detekcji łuku

Fig. 2. Factors affecting the arc velocity measurement: a - the “visible” luminous arc zone, s - the arc-detection zone

To achieve a high measurement precision the application a large number of probes is required. This means that the sensors used should be characterised with a narrow arc-detection zone s . The increase in the number of sensors can lead to an unacceptably short l_{cz} . In such a case several recording channels have to be applied, so that neighbour probes could be connected to different channels. After adequate formation of received information the channels create impulses that are delivered to the common output.

It would be profitable, if the selected sensors were only sensitive to the short-wave part of the visible radiation. This would narrow the arc-detection zone. Unfortunately, the maximum sensitivity of most commercially available optoelectronic elements appears in the red or infra-red zone.

In experiments the separation between neighbouring sensors l_{cz} was defined with the consideration of the width of the luminous zone, the required length of the arc track in one half-period and the number of measuring points m . Applied a large number of recording channels k . To each channel every k^{th} sensors was connected. The k channels were chosen considered the sensitivity zone of sensors s , the prognosed maximum distance of the arc transfer in one half-period T , the average arc velocity v_u , evaluated with the consideration of the simplified analysis presented in chapter 5, and the breadth of the luminous arc zone a , estimated based on the literature [4]. The value of a in the available literature takes a value in the range from 10 mm to 50 mm. It changes almost linearly with current. On this basis, the minimum number of channels enabling the arc velocity recording with the help of m evenly separated sensors during one half-period is given by

$$k > [(m+1) \cdot (2 \cdot a + 4 \cdot s)] \cdot (T \cdot v_u)^{-1}, \quad (1)$$

and the sensors separation l_{cz} describes the following equation

$$l_{cz} = 50 \cdot T \cdot v_u \cdot [(m+1) \cdot k]^{-1}. \quad (2)$$

The distance between sensors connected to the same channel results from

$$l_i = k \cdot l_{cz}. \quad (3)$$

In experiments the length of measuring section l_{pom} was assumed, as the distance covered by the arc at the average velocity taken from the literature for the highest arc current in full period T of the system frequency.

3. Experimental system of arc velocity measurement

The investigations were performed in the set-up shown in Fig. 3. The arc initiated with a thin wire moved along aluminium bus-bars, 40x10 mm in cross-section, arranged horizontally in a flat system.

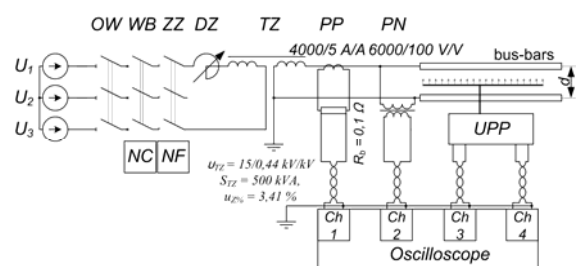

Rys. 3. Schemat stanowiska pobierczego: U_1, U_2, U_3 – napięcie fazowe zasilania, OW – odłącznik, WB – wyłącznik bezpieczeństwa, NC – nastawnik czasowy, ZZ – załącznik zwarcioowy, NF – nastawnik fazowy, DZ – dławik regulacyjny, TZ – transformator wielkoprowadowy, PP – przekładnik prądowy, PN – przekładnik napięciowy, UPP – układ pomiaru prędkości; Ch – wejście sygnałowe oscyloskopu

Fig. 3. Diagram of test set-up for arc velocity measurement : U_1, U_2, U_3 - the mains voltage, OW - the isolator, WB - the circuit breaker, NC - the controller, ZZ - the making switch, NF - the phase controller, DZ - the current setting reactor, TZ - the high-current transformer, PP - the instrument current transformer, PN - the instrument voltage transformer, UPP - the arc velocity measuring set-up; Ch - the oscilloscope input signal

The used arc-velocity measuring set-up UPP, shown in Fig. 4, consists of two recording channels. To each of them 10 sensors are connected delivering light signals through optical fibres. The UPP transforms the light signals into electrical ones, and forms them creating narrow impulses, marking the moment when the arc passes a sensor. All impulses, from both channels are sent into a common output.

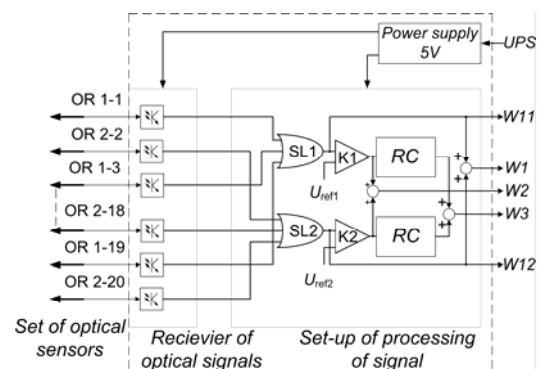

Rys. 4. Schemat blokowy układu pomiaru prędkości UPP: OR - odbiornik optyczny; SL - sumator logiczny, K - komparator; U_{ref} - napięcie odniesienia; RC - układ różniczkujący

Fig. 4. Arc velocity measuring set-up UPP: OR - the receiver of optical signals; SL - the logical adder, K - the comparator; U_{ref} - the reference voltage; RC - the differentiator

Example traces of signals produced by UPP (a) and the arc velocity obtained on this basis (b) are shown in Fig. 5.

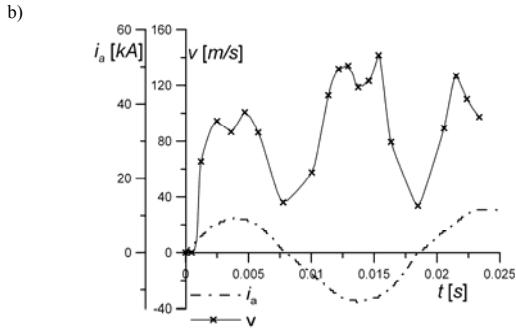
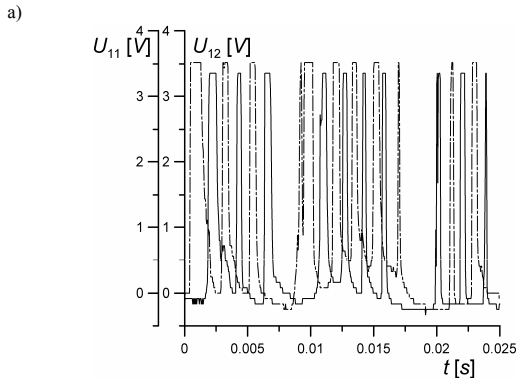

Rys. 5. Przykładowe przebiegi: a) sygnały z układu UPP, b) prąd probierczy i_a oraz pomierzona prędkość łuku v
 Fig. 5. Example traces: a) the UPP produced signals, b) the test current i_a and the measured arc velocity v

4. Arc velocity changes

The measurements were conducted for prospective short-circuit currents I_k taken from the range of 1 kA - 10 kA and three separations between bus-bars axes: $d = 90$ mm, 110 mm, 150 mm. The example measured arc velocity curves are compared with those calculated on the basis of the simplified model of the arc movement along conductors, Fig. 6.

The measured and calculated curves of the arc velocity are similar, particularly in the case of small currents. More pronounced difference can be noted at maximums and minimums (Fig. 6b). They probably result from swirls of the luminous zone due to high arc velocity, errors of measurements and simplifications introduced into the arc-movement model described with the equation (4). The differences increase as the arc velocity.

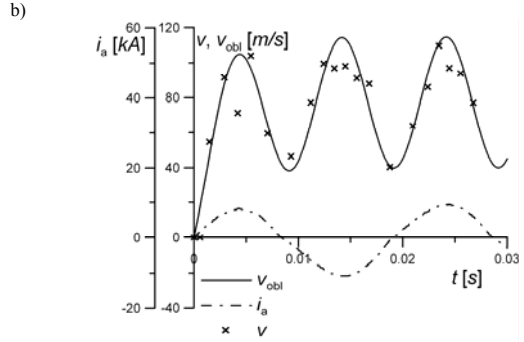
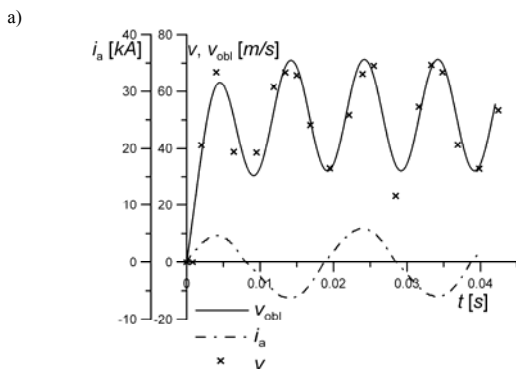

Rys. 6. Prędkość łuku obliczona i pomierzona: a) $I_{RMSa} = 4,336$ kA, $d = 90$ mm, $k_{ogr} = 0,9$, $t_{\delta} = 8,00$ ms, $v_u = 49,44$ m/s, $\Delta v = 37$ m/s, b) $I_{RMSa} = 6,772$ kA, $d = 90$ mm, $k_{ogr} = 0,83$, $t_{\delta} = 8,36$ ms, $v_u = 77,32$ m/s, $\Delta v = 74,7$ m/s
 Fig. 6. The arc velocity calculated and measured: a) $I_{RMSa} = 4,336$ kA, $d = 90$ mm, $k_{ogr} = 0,9$, $t_{\delta} = 8,00$ ms, $v_u = 49,44$ m/s, $\Delta v = 37$ m/s, b) $I_{RMSa} = 6,772$ kA, $d = 90$ mm, $k_{ogr} = 0,83$, $t_{\delta} = 8,36$ ms, $v_u = 77,32$ m/s, $\Delta v = 74,7$ m/s

5. The simplified model of arc movement

Based on the earlier investigations [4], it is possible to define the instant value of a single-phase arc velocity in a flat, horizontal arrangement of aluminium bus-bars

$$v_{obl} = \left(v_u - \frac{\Delta v}{2} \right) \cdot \left(1 - e^{-\frac{t}{T_1}} \right) + \Delta v \cdot \left[\sin^2(\omega \cdot t) - \sin^2(\delta) \right] - \Delta v \cdot \sin^2(\delta) \cdot e^{-\frac{t}{T_1}} \quad (4)$$

when the arc current is symmetrical and the average arc velocity v_u is known. The equation (4) reflects results of measurements with currents taken from the range of 5 kA < I_k < 10 kA, for bus-bars separation $d < 110$ mm. The difference between v and v_{obl} decreases when the current reduces. The dependence (4) only considers the arc velocity components due to the effect of electrodynamic forces.

The amplitude of arc velocity Δv in (4) can be calculated from the following dependence

$$\Delta v = \frac{v_u}{2 \cdot \omega^2 \cdot T_1^2 - 0,5} \quad (5)$$

The value of Δv depends on the average velocity v_u , the frequency of short-circuit current ω , and the arc time-constant T_1 , achieving about 3 ms. Its value did not change significantly in the conducted investigations.

The average arc velocity v_u applied in (4) and (5) is calculated from the dependence

$$v_u = 2 \cdot K_L \cdot k_{ogr}^2 \cdot (I_k \cdot 10^{-3})^2 \quad (6)$$

A good approximation of v_u is given in the literature [1,5]

$$v_u = \sqrt{\frac{F_D}{k_A}} = \frac{1}{c_L} \sqrt{\frac{F_D}{S_l \cdot \rho}} \quad (7)$$

where: the F_D - the electrodynamic force, c_L - the coefficient of aerodynamic drag, S_l - the virtual arc-column cross-section obtained by projection on the plane orthogonal to the bus-bars axes, ρ - the gas density.

The arc velocity v_u (6) is proportional to the prospective short-circuit current square (I_k)², the coefficient of short-circuit current limitation by the fault-arc k_{ogr} , and the parameter K_L , being a function of the prospective short-circuit current I_k and the bus-bars separation. d The last function is depicted in Fig. 7.

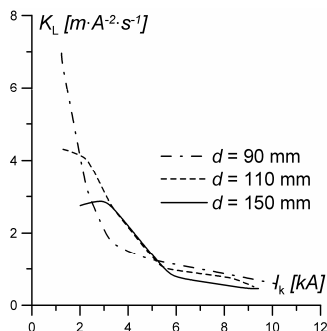

Rys. 7. Zmienność parametru K_L w funkcji spodziewanego prądu zwarcowego I_k
 Fig. 7. Parameter K_L in function of the prospective short-circuit current I_k

The angle δ in (4) depends on the coefficient of short-circuit current limitation by the fault-arc k_{ogr} . It took a value from the range of 20° – 45° in all experiments. It changed inversely proportional as k_{ogr} .

The instant arc velocity changes as the arc current. Therefore two its components can be distinguished (6). A velocity component growing exponentially to the mean value v_u , and an oscillatory component associated with frequency of the current. The arc velocity for small bus-bar separations d increases in the first half-wave of the current and oscillates around v_u . For large separations d , the arc velocity increases over the whole period T .

6. Summary

The described method of arc velocity registration with the application of optoelectronic detectors is practical for a quite wide range of velocities. Although the results are discrete, they can be satisfactory at a great number of points.

Sensors only provide information linked to a selected zone of the moving arc. This facilitates selection of the part of the arc to investigate. Choosing special frequency characteristics of sensors a desired temperature zone of the arc can be watched. Observations of smoothly moving arcs do not create problems. The enhancement of measurement precision requires an increase in the number of sensors, which regrettably needs additional recording channels.

Utilization of light sensors and fibre-optic techniques guarantees galvanic separation of the measuring circuit reducing the level of disturbances.

7. Bibliography

- [1] Fehling H.: Elektrische Starkstromanlagen. Berlin VDE-Verlag 1984.
- [2] Jakob K., Schels W.: A new intelligent digital arc detection system for air- and gas-insulated switchgear CIREC 97. Conference Publication 1997.
- [3] Kochel Z., Rodoń F., Prochownik P.: Fibre optic arc protection systems type ZL of medium and low voltage transformer substations and switchgears. 9th Int. Symposium on "Short – Circuit Currents in Power Systems", Cracow, 11-13 October 2000. Lodz: Tech. Univ. of Lodz 2000.
- [4] Kowalak D.: Dynamika jednofazowego łuku awaryjnego. Praca dyplomowa, Politechnika Gdańska, Wydział Elektrotechniki i Automatyki, Katedra Wysokich Napięć i Aparatów Elektrycznych, 2006.
- [5] Partyka R.: Badanie skutków zwarć łukowych w rozdzielnicach osłoniętych. Wydawnictwo Politechniki Gdańskiej, Gdańsk 2006.

Artykuł recenzowany

KONFERENCJE NAUKOWO-TECHNICZNE

IV Międzynarodowy Kongres ICPM 2007 - "Obróbka Precyzyjna"

Kielce-Sandomierz, 25-28 września 2007

Mam zaszczyt poinformować, że Wydział Mechatroniki i Budowy Maszyn Politechniki Świętokrzyskiej przy współpracy Wydziału Mechatroniki Politechniki Warszawskiej oraz Wydziału Mechanicznego Politechniki Krakowskiej organizuje w dniach 25-28 września 2007 roku IV Międzynarodowy Kongres ICPM – „Obróbka Precyzyjna”.

Wyżej wymieniony Kongres jest organizowany z okazji 190-lecia utworzenia w Kielcach Szkoły Akademiczno-Górnicy, pierwszej wyższej uczelni technicznej w Polsce, a patronat naukowy nad nim objęły Komitet Budowy Maszyn Polskiej Akademii Nauk oraz Komitet Metrologii i Aparatury Naukowej Polskiej Akademii Nauk.

Obrady będą odbywać się w Sali Rycerskiej Zamku Kazimierzowskiego w Sandomierzu oraz w Politechnice Świętokrzyskiej w Kielcach.

Przewodniczącym Komitetu Naukowego Kongresu jest prof. dr inż. Kazimierz E. Ocoś.

Tematyka Kongresu obejmuje zagadnienia dotyczące szeroko pojętych technologii obróbki precyzyjnej, a także zagadnienia metrologii warstwy wierzchniej i kontroli jakości wyrobów.

W szczególności tematyka Kongresu obejmuje zagadnienia, takie jak:

- obróbka skrawaniem, obrabiarki, narzędzia skrawające,
- mikro- i nanotechnologie,
- ekologiczne aspekty obróbki skrawaniem,
- niekonwencjonalne procesy obróbki skrawaniem,
- monitorowanie i sterowanie procesami obróbki,
- metrologia i kontrola jakości,
- pomiar i analiza jakości oraz właściwości eksploatacyjnych obrabianych powierzchni,
- optymalizacja i ekonomika produkcji,
- zarządzanie i organizacja w aspektach zapewniania wysokiej jakości produktów.

Serdecznie zapraszam do uczestnictwa w Kongresie przedstawicieli jednostek naukowych oraz przemysłu.

Z wyrazami szacunku
 Prof. Stanisław ADAMCZAK
 Przewodniczący Komitetu Organizacyjnego

