



## THE CONCEPTION OF UNCERTAINTY ANALYSIS OF RELIABILITY ASSESSMENT OF THE MC TYPE DIESEL ENGINE LUBRICATING OIL SYSTEM

**Roman Liberacki**

*Gdansk University of Technology*  
*ul. Narutowicza 11/12, 80-950 Gdańsk, Poland*  
*tel.: +48 58 3471850, fax: +48 58 3472430*  
*e-mail: romanl@pg.gda.pl*

### **Abstract**

*In the article elements consisting on uncertainty of reliability assessment of the MC type diesel engine lubricating oil system have been discussed. The conception of uncertainty analysis of the system reliability assessment, on computational example, has been introduced. Moreover, the interpretation of the received result - burdened with large uncertainty, has been proposed.*

**Key words:** *reliability, uncertainty, diesel engine, lubricating oil system*

### **1. Introduction**

The key problem in making reliability analysis of systems, like lubricating oil system for diesel engine, is getting credible reliability data, which are the entrance data to created mathematical models. The probabilities of suitable technical elements failures are on generality these data, as well as the probabilities of the human errors (crew which exploits those technical devices).

Problem in this place appears - where from to draw these data. The sources of reliability data for technical structures can be: tests, data gathered with operation, experts' opinions. To estimate human errors probabilities the methods applied in nuclear energetic can be used, where they be led on wide scale. The description of these methods one can find in foreign literature [2, 8, 10, 12, 13, 14] as well as in national studies [3, 7].

We should remember, that reliability assessment of technical devices and energetic systems is always burdened with uncertainty, which we try to introduce as some numerical interval, including in our conviction marked value (reliability for given period of time). In this place we should underline clearly, that there is no certainty never, that appointed interval contains really in demand value. This is because of lack of full knowledge about system, his surroundings and influences inside the system and in relationship system - surroundings.

Applying the clean probabilistic approach to reliability assessment in such conditions is in the author's opinion inappropriate. The calculus of probability requires the possession of exactly definite data of relating random events. In practice, in the best case we can dispose with large number of empirical data, which will allow us to qualify the statistical rights (the distributions of random variables) relating to elements of considered system. However, it is proper to turn the attention, that the distribution of random empirical variable, used in statistics, it is not the same what the distribution of probability density function. We take into account fact this applying interval estimation in demand value, what simultaneously the uncertainty of reached result reflects.

In many situations we possess a small set of statistical data or we have outright to appeal to experts' opinions in aim gaining over reliability data. The use of possibility measure or fuzzy numbers seems to be reasonable solution in such case. They will allow us to estimate reliability of

considered system as well as uncertainty of this estimation. Naturally it is possible to join the statistical methods with the fuzzy set theory methods or with the possibility theory together.

## 2. Lubricating oil system for the MC – type diesel engine

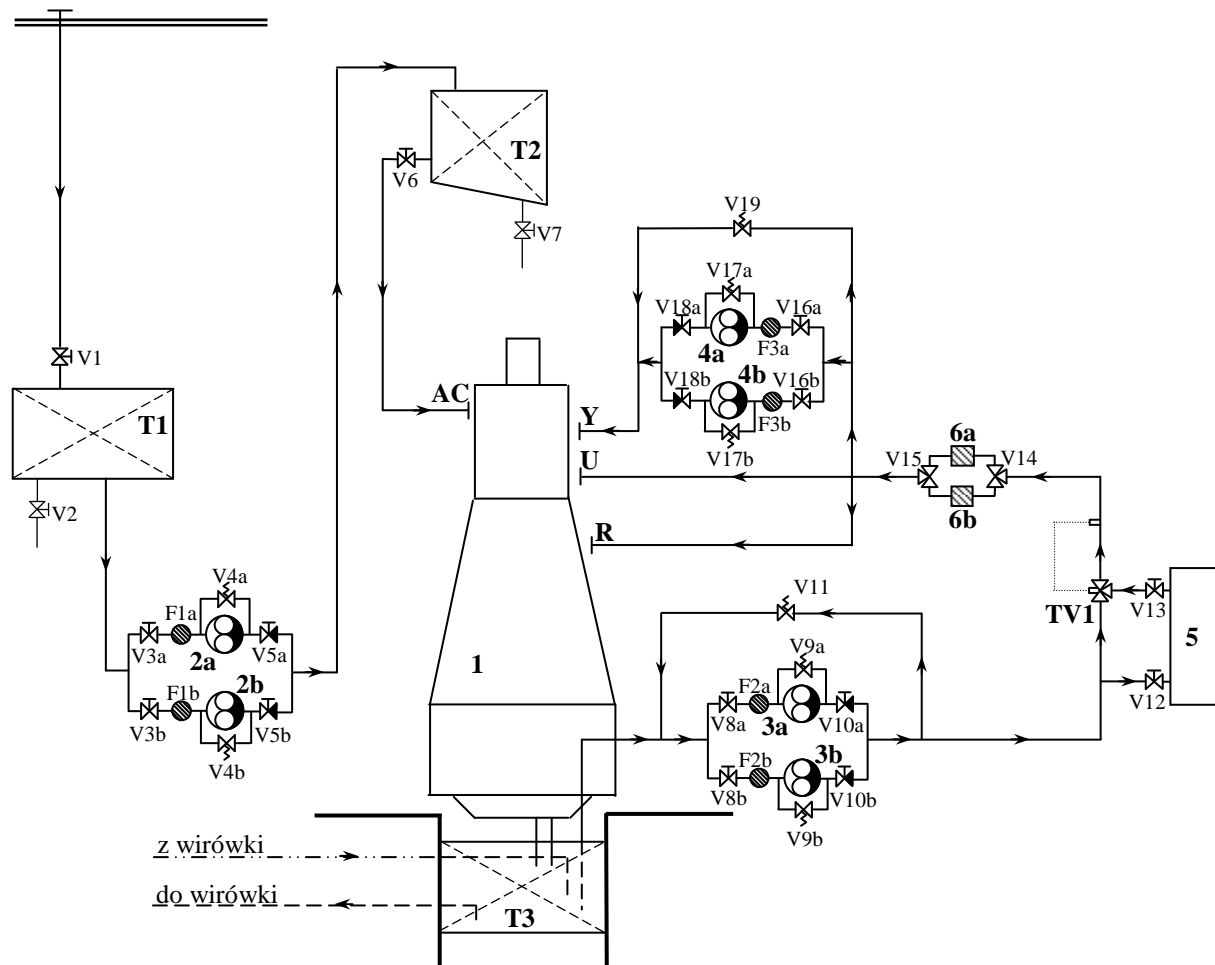

Fig. 1. Lubricating oil system for the MC – type diesel engine: 1 - diesel engine; 2a, 2b – cylinder lubricating oil transfer pumps; 3a, 3b - lubricating oil pumps; 4a, 4b – camshaft lubricating oil booster pumps; 5 – lubricating oil cooler; 6a, 6b – lubricating oil duplex filter; T1 – cylinder lubricating oil storage tank; T2 – cylinder lubricating oil service tank; T3 – lubricating oil bottom tank; TV1 – thermostatic valve; V... – valves; F... – suction filters

Lubricating oil system for the MC – type diesel engine is the object of considerations. The scheme of this system is shown in Fig. 1.

Building relative model of the system following assumptions have been made: stop the pumps can be caused with lack of the power supply among different causes, the lubricating oil purifying system is fit, all stop valves and non return valves are in open position (except of valves V2 and V7), all tanks are equipped with signaling alarm of low level, duplex filter is equipped with signaling alarm of pressure drop to high, suction filters are equipped with signaling alarm of pressure drop to high, the critical leakage of oil from system requires immediate stop of engine.

The reliability of lubricating oil system, for considered period of time, means the probability, that in this period of time the work of engine will be possible. We by event of failure of lubricating oil system understand such event which extorts stop engine or causes stop engine directly.



### **3. Elements consisting on uncertainty of reliability assessment of the MC type diesel engine lubricating oil system**

On uncertainty of reliability assessment of considered system consists:

- uncertainty of relative model,
- uncertainty of mathematical model based on the relative model,
- uncertainty resulting from possessed reliability data.

#### **3.1. Uncertainty of relative model of system**

Under notion of relative model of system one should understand a fault tree or reliability structure created for the system, which in graphic form reflect all sequences of basic events leading to appearing the event of failure of considered system.

The fault tree method found the wide use in reliability analyses of technical systems. The method is applied in nuclear energetic, chemical industry, aviation, land transportation. It is also commanded for shipping systems by developed under auspices of International Sea Organization (the IMO) Formal Safety Assessment method [11].

Uncertainty of relative model results from concern, or really sequences of basic events, recorded in form of fault tree or reliability structure, lead to appearing the event of failure of considered system or if any essential sequence of events was not skipped.

Verification of correctness of such model can be done using the experts' courts only. If experts will state, that all recorded in the fault tree sentences are true, as well as they will not be able to show different sequences of events, than these which were used already, then we can believe, that there are no bases to judge, that created model is inadequate.

We will attribute such a model plausibility measure  $1(P_l = 1)$ . It means that we recognise our model for plausible. The plausibility measure 1, in distinction from probability measure 1, does not mark the hundred - percent certainty to adequacy of model (an additional expert would can find in the model mistake). The plausibility measure and the necessity measure were introduced by Shafer, how the authors write in [1].

It is obvious, that it is proper so long to consult with experts the correctness of model as well as to make possible corrections until we will can attribute the model plausibility measure 1.

#### **3.2. Uncertainty of mathematical model**

We build mathematical model with algebraical structure with support of fault tree, using the minimal cut sets method. We do not achieve in this case formula for reliability of the system, described with the fault tree, but formula for the lower boundary of reliability of this system. We can rebuild the fault tree on the success tree, then to solve the success tree using the minimal path sets method and to receive the formula for the upper boundary of reliability of this system. In the result we receive some area in which the demand function of reliability contains. We proceed so, because the exact delimitation the function of reliability of complex systems is in general very difficult.

In majority of reliability analyses we give up from marking the upper boundary of reliability. Only the lower boundary of reliability is marked. In this case we can say, that the reliability of system for considered interval of time is not lower than appointed value. Approach such is the working on principle of investigation of the worst case. It is obviously reasonable. Reliability of devices and technical systems influences on safety of those technical objects, men, natural environment as well as on achieved economic effects. Pessimistic approach to reliability assessment is therefore reasonable.

Simplifications used in the minimal cut sets and minimal path sets methods cause, that for considered period of time, we receive the result in the form of the interval, in which the reliability of system (modeled with the use of the fault tree and the success tree methods) contains.

To receive more precise results, we should abandon the fault tree and the success tree methods, than to try to model the reliability of the system with the help of the reliability structure method and to mark using this method exact formula on reliability of the system. However in practice it is very difficult, as it was said earlier. That is why the majority of system reliability analysts inclines to use only and the minimum cut sets method.

### **3.3. Uncertainty resulting from possessed reliability data**

There are several situations possible with getting reliability data. We seek for such data for technical elements and for human as well.

When we have at our disposal a large statistical sample or a small statistical sample, but we know the statistical distribution of the time to failure for elements or we use the data given in reliability handbooks or guides, then we define the statistical distribution of the time to failure and parameters of the distribution on definite significance level (e.g.  $\alpha = 0,1$ ), in compliance with laws of mathematical statistics.

Uncertainty of reliability assessment of the system for considered period of time is delimited then by numerical interval. We receive this interval by substituting the 5 % quantile and 95 % quantile of the statistical data to the formula describing reliability function of the system.

When we have at our disposal a small statistical sample and we do not know the statistical distribution of the time to failure for elements, then the problem can be solved using the possibility theory or the fuzzy sets theory. In case of using the possibility theory the uncertainty of estimation of reliability contains in numerical interval limited with measure of possibility and the measure of necessity [1].

The case in which we dispose no reliability data stays to consider. We have to reach the data in some way. We can try to find out these data in support of experts' opinions. Previous experiences show, that experts have difficulties with formulating their opinions in the form of numerical data. I propose so, to ask experts to formulate their opinion in the form of the linguistic probability terms like: probability, that the event of failure of given kind of element will happen in considered period of time is: very high, high, average, low, very low. We can transform the linguistic variables into the data in the form of the fuzzy numbers without experts' participation. The uncertainty of estimation of reliability is represented by the fuzzy number. Questions these became described wider by the author in [5, 6].

## **4. Reliability of the system with the uncertainty of the assessment taken into consideration**

### **4.1. Uncertainty of relative model**

The relative model, built for analysed system had the form of fault tree. In compliance with this what was written earlier (subentry 3.1.), the plausibility measure 1 was given for the fault tree. The structure of the fault tree is very complex, and that is why it was not introduced in this article. The fault tree structure the reader can find in study [6].

### **4.2. Uncertainty of mathematical model**

The mathematical model was built with support of the fault tree, using the minimal cut sets method and the minimal path sets method. Moreover the reliability structure was built to avoid inaccuracies resulting from use of minimal cut sets and minimal path sets methods.

To illustrate uncertainty of the mathematical model the calculations of reliability of lubricating oil system were done:

- a. using the reliability structure method (exact value of reliability)
- b. using the minimal cut sets method (lower boundary of reliability)
- c. using the minimal path sets method (upper boundary of reliability).

The reliability of the system was calculated for one year of service and for four years of service accepting, that the system at the beginning was new. Moreover, to show the uncertainty of mathematical model – a clean hypothetic assumption was taken, that the reliability data are certain.

The set of reliability data used in calculations, the fault tree and the reliability structure the reader can find in study [6]. Results of calculations were introduced in Tab. 1.

Tab. 1. Reliability of lubricating oil system for the MC type engines calculated using: the minimal path sets method, the exact method, the minimal cut sets method

Reliability of the system	1 year	4 years
Minimal path sets method	100 %	100 %
Exact method	92,7 %	65,3 %
Minimal cut sets method	92,1 %	51,3 %

Received results reflect the uncertainty of mathematical model, when we use the minimal cut sets and the minimal path sets methods. It was said in subsection 3.2., that the minimal cut sets method is the most often used method - as working on principle of the worst case. It is proper to turn attention, that in considered lubricating oil system case - the value of reliability calculated using the exact method is more approximate to this got using the minimal cut sets method, than these got with minimal path sets method.

Because it was possible to get exact formula for reliability of the system, therefore in more far considerations only this formula will be taken under attention. It will avoid us from received mathematical model uncertainty.

#### 4.3. Uncertainty resulting from possessed reliability data

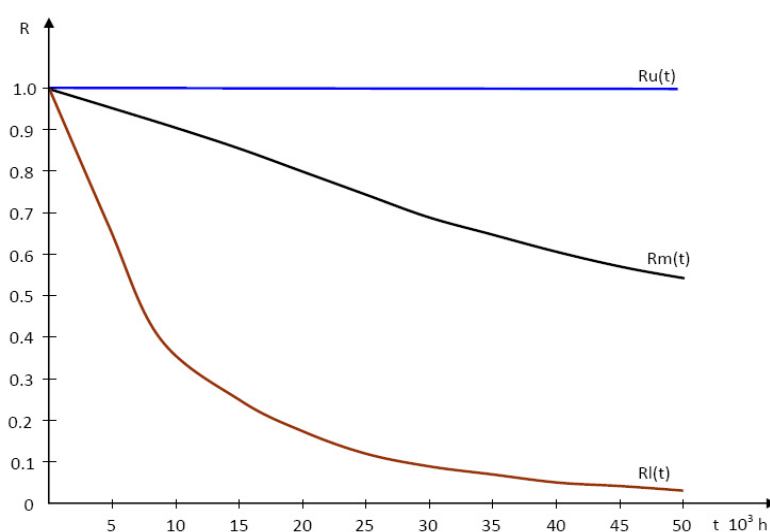

Fig. 2. The reliability function of the lubricating oil system for the MC – type diesel engine, considering the uncertainty of accomplished assessment;  $R_m(t)$  – reliability function appointed with the use of median values of reliability data,  $R_l(t)$  – lower boundary of reliability function,  $R_u(t)$  – upper boundary of reliability function

Reliability data for technical elements were taken from guide [9] as well as from study [4]. These data have a character of mean failure rate, what implies the use of the exponential distribution of time to failure for those technical elements. The ASEP – HRAP method was used to determine human error probabilities. Failure rate boundaries for technical elements were been delimited with the use of the 5 % quantile and 95 % quantile of lognormal distribution of the mean failure rate values. Similarly, the boundaries of human error probabilities were been delimited with the use of the 5 % quantile and 95 % quantile of lognormal distribution. Received results are shown in Fig. 2.

## 5. Proposal of interpretation of result with the large uncertainty

The reliability data used in calculations were burdened with large uncertainty, what was transferred on large uncertainty of reliability assessment of the lubricating oil system. Received results shown in Fig.2. tell us clearly, that it is very hard to assess reliability of our system. In support about such uncertainty results it is very hard to take the decision: to permit the system to work or to phase out the system from work. The decision is particularly hard for longer times of work.

It there is no possibility to define the reliability data more precisely - and the same to reduce the area of uncertainty, then we can try to analyse received results with the use of fuzzy numbers.

Let's accept, that we are interested in the reliability of the lubricating oil system for working time 4 years (35040 h) since the moment of putting this system to use. According to the author's model we can affirm, that for considered period of time: the upper boundary of reliability of the system equals 0.999; the median value of reliability of the system equals 0.653; the lower boundary of reliability of the system equals 0.068. We will demonstrate the received result in the form of fuzzy number  $A_R$  "about 0,653" in Fig. 3.

We can also affirm respectively, that for considered period of time: the lower boundary of unreliability of the system equals 0.001; the median value of unreliability of the system equals 0.347; the upper boundary of unreliability of the system equals 0.932. We will demonstrate the received result in the form of fuzzy number  $A_F$  "about 0,347" in Fig. 3.

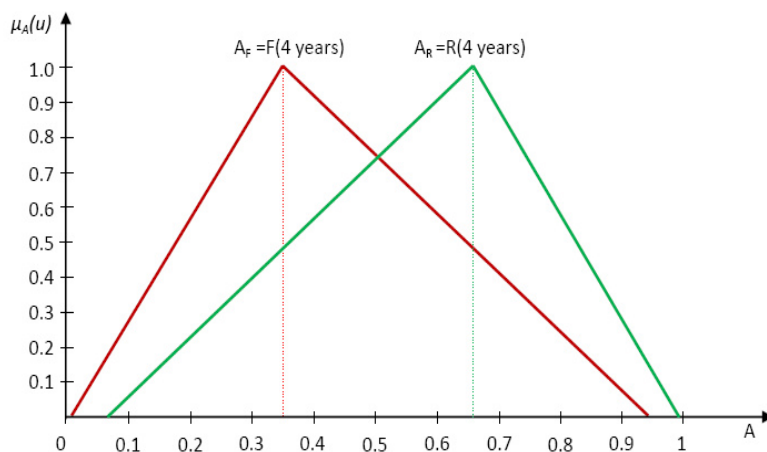

Fig. 3. The reliability value  $A_R$  and the unreliability value  $A_F$  of the lubricating oil system for the MC - type engine evaluated for working time 4 years, expressed in form of fuzzy numbers

Looking at Fig. 3. we can draw out following conclusions: 1) Generally, reliability of the system is higher then the unreliability. 2) The median value of probability, that system failure or system failures will occur in considered period of time equals 0.347. 3) The median value of probability, that no system failure will occur in considered period of time equals 0.653.



Let's try now to express the reliability of our system in terms of linguistic probability. To do this we will put in the same figure values of the linguistic reliabilities (established before) and the value of reliability of the system received in the form of fuzzy number  $A_R$ , for considered in our example period of time. The result is shown in Fig. 4. We can notice, that fuzzy value of reliability of our system belongs in different degree to every one from fuzzy numbers valuating linguistic reliability.

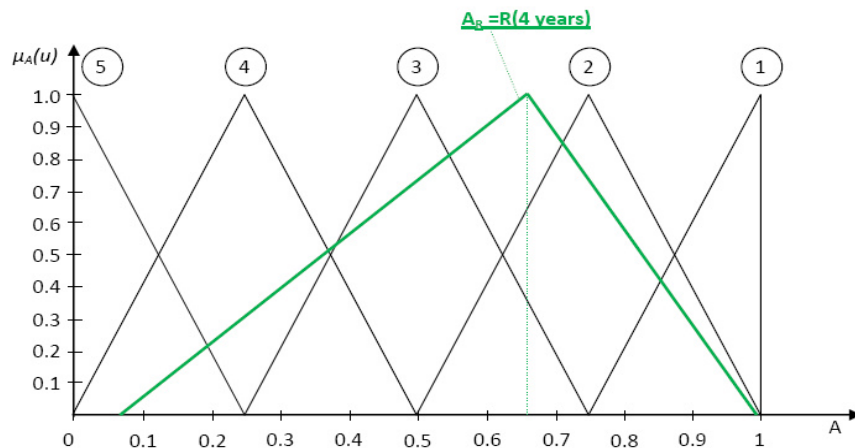

Fig. 4. Valuating the linguistic reliabilities

1 - very high reliability, 2 - high reliability, 3 - reliability about 50 %, 4 - low reliability, 5 - very low reliability,  
 $A_R$  - the reliability of considered system given in the form of fuzzy number

Let's accept the measure of possibility, that reliability of the system belongs to the valuating number  $A_i$  as:  $\Pi_i = \max(\mu_{A_R} \wedge \mu_{A_i})$ . We will take down the results in Tab. 2. The sum total of possibility measures (in distinction from probability measures) according to the possibility theory can be greater than 1. In our case the sum is 2.81. Of course, we can transform these values to the form of percentages to give in total 100 %.

The results collected in Tab. 2. shows, that the highest possibility is that the reliability of lubricating oil system for the MC - type engines, in considered period of time is high – it means the reliability value contains in interval [0.5 - 1). Possibility this was estimated on 30% of all possibilities. The lowest possibility is that the reliability is very small – it means the reliability value contains in interval [0 - 0,25). Possibility that was estimated on 8% of all possibilities.

Tab. 2. The comparison of possibility measures, that reliability of lubricating oil system belongs to established fuzzy numbers valuating reliability

Linguistic values of reliability	Intervals of numerical values	Possibility measure $\Pi_i$ that reliability of the system belongs to $A_i$
$A_1$ – reliability very high	[0,75 – 1)	$\Pi_1=0,42$ (15 %)
$A_2$ – reliability high	[0,5 – 1)	$\Pi_2=0,85$ (30 %)
$A_3$ – reliability about 50 %	[0,25 – 0,75)	$\Pi_3=0,81$ (29 %)
$A_4$ – reliability low	[0 – 0,5)	$\Pi_4=0,51$ (18 %)
$A_5$ – reliability very low	[0 – 0,25)	$\Pi_5=0,22$ ( 8 %)

## 6. Final remarks

In the case of large uncertainty of estimated reliability of system, as in considered example (Fig. 2.) it is very hard to take rational decisions: to permit the system to work or to phase out the system from work, especially for longer time in service.

What should be done in such situation? First of all, we should try to gain over reliability data burdened with smaller uncertainty. If this is not possible, we can analyse received results using fuzzy numbers according to the author's proposal (Tab. 2.), what gives us enough good knowledge for undertaking the decision about more far exploitation of system.

The proposed method of reliability assessment with the large uncertainty has to be improved.

The studies on appointment of numerical boundaries of estimations of linguistic reliabilities of diesel engines' systems in the closest time will be led. The boundaries not at all have to be and they should not be spread equably like it was shown in Fig. 4.

## References

- [1] Dubois, D., Prade, H., *Possibility Theory. An Approach to Computerised Processing of Uncertainty*, New York, 1988.
- [2] Gertman, D.I., Blackman, H.S., *Human Reliability and Safety Analysis Data Handbook*, New York, 1994.
- [3] Kosmowski, K.T., *Ocena niezawodności operatora w realizacji wybranych funkcji w procesie sterowania na przykładzie instalacji wytwarzania energii elektrycznej statków serii B 488*, Politechnika Gdańska, Gdańsk, 1997.
- [4] Liberacki, R. Nowak, P., *Wyniki symulacji bezpieczeństwa napędowego statków serii B 488*, opracowanie wewnętrzne, Politechnika Gdańska, Gdańsk 1998.
- [6] Liberacki, R., *Niepewność oszacowania niezawodności instalacji okrętowych*, XXVIII Sympozjum siłowni okrętowych, Gdynia, 2007.
- [7] Liberacki, R., *Koncepcja szacowania danych niezawodnościowych dotyczących urządzeń energetycznych w przypadku uzyskania statystyk o małej liczności bądź braku danych niezawodnościowych dotyczących określonych urządzeń*, opracowanie wewnętrzne, Politechnika Gdańska, Gdańsk, 2007.
- [8] Radkowski, S., *Podstawy bezpiecznej techniki*, Oficyna wydawnicza Politechniki Warszawskiej, Warszawa, 2003.
- [9] Swain, A.D., Guttman, H.E., *Handbook of Human Reliability Analysis with Emphasis on Nuclear Power Plant Applications*, Final Report, prepared for U.S. Nuclear Regulatory Commission, August, 1983.
- [10] DNV, *Offshore Reliability Data Handbook*, OREDA, 1998.
- [11] IMO (MEPC 45/13), *Formal Safety Assessment Including Environmental Indexing of Ships*, 27 June 2000.
- [12] IMO (MSC 66/INF.8), *A methodology for formal safety assessment of shipping*, London, 1996.
- [13] Nuclear Energy Agency, Committee on the Safety of Nuclear Installations, *Critical Operator Actions, Human Reliability Modeling and Data Issue*, Final Task Report, OECD, 1998.
- [14] Office of Nuclear Regulatory Research, US Department of Commerce, NUREG/CR – 2300, *PRA Procedures*
- [15] *Guide, A Guide to the Performance of Probabilistic Risk Assessment for Nuclear Power Plants*, Final Report – Vol.1., Washington DC., Jan 83.
- [16] Safety and Reliability Directorate UK Atomic Energy Authority, *Human Reliability Assessors Guide*, October, 1988.

