



SOME ADJUSTMENT AND EXPLOITATION PROBLEMS OF THE CONTROLLABLE PITCH PROPELLER PNEUMATIC AND HYDRAULIC CONTROL SYSTEMS

Czesław Dymarski

*Gdansk University of Technology
Faculty of Ocean Engineering and Ship Technology
11/12 G. Narutowicza Str., 80-233 Gdańsk, POLAND*

Abstract

The paper presents selected problems of the controllable pitch propeller (CPP) pneumatic and hydraulic control systems. For this aim a description of the collision of the rescue fire ship with the trestle of the fuel pier in the North Port in Gdańsk was used. Activities undertaken by author, included analysis and an experiment conducted by a commission, permitted to explain the reasons of the event. It is expected that presented description of the works and their results will be a useful knowledge material for designers and users of the control systems.

1. Introduction

Few years ago in the North Port in Gdansk the rescue fire ship during last stage berthing operation suddenly started to move rapidly ahead with grooving speed and in short time struck the trestle of the fuel pier in the North Port in Gdańsk. According to the captain and the crew relations after setting control lever of the CP Propeller in “astern” position in wheelhouse for final stopping of the ship, the pitch automatically was setting in “full ahead” position. It resulted in rapid grow of the main engine load and ship speed. Because attempts of the CPP pitch changing did not succeed and the vessel quickly moved close to the pier, captain pressed “switch off” button of the main engine, ordered to throw an anchor and left the wheelhouse. A moment later superstructure of the ship struck the concrete trestle. Fortunately, because of a better elasticity of the superstructure than the bow part of the ship hull, the dynamic force of a collision was reduced and damages of the ship equipment as well as the trestle infrastructure were smaller. Fortunately, there were no fatal victims, but not serious injuries only. Also, there were no dangerous damages to main ship systems such as fuel, ballast or bilge systems. Similarly, on the trestle only fresh water pipeline was damaged, which lay along the fuel pipe line but on side close to edge of the trestle.

After towing away the ship and mooring her at safe part of the wharf a detailed inspection of the propulsion system was carried out, especially controllable pitch propeller. Some investigation actions which were done with the aim to clarify the reasons of the event, are presented in the following parts of the paper.

2. Description of the analysed controllable pitch propeller control system

Controllable pitch propeller, which is applied on the ship has a diameter of 2,1m and is

driven by the middle – speed diesel engine through a reduction gear. The CPP control system is a pneumatic – hydraulic type. The remote control from the wheelhouse and from the engine control room is pneumatic and local direct control is hydraulic. Simplified drawing of the propulsion system with a scheme of the hydraulic part of the CPP control system is presented on fig. 1.

The controllable pitch propeller 1 is mounted on the flange of the propeller shaft 2, which is located on journal bearing at the stern tube. The propeller shaft has a coaxial hole with a control rod inside it. One end of the control rod is connected with a pivot mechanism of the blades located in the propeller hull and second end is fixed to a piston of the hydraulic cylinder 4. The hydraulic cylinder is simultaneously a section of the main shaft and is connected with the flange clutch of the propeller shaft at one end with an output shaft of the gear 5 at the second end. An oil distribution box is coaxial attached to a fore wall of the gear. In the oil distribution box there are: a directional control valve, a feedback mechanism and a transmitter of a real pitch indicator 22. On a side wall of the oil distribution box there is an installed lever 8 of the manual control of the propeller pitch. The lever is connected to a pneumatic servomotor 7 through pneumatic connector (look item 5 on fig. 3).

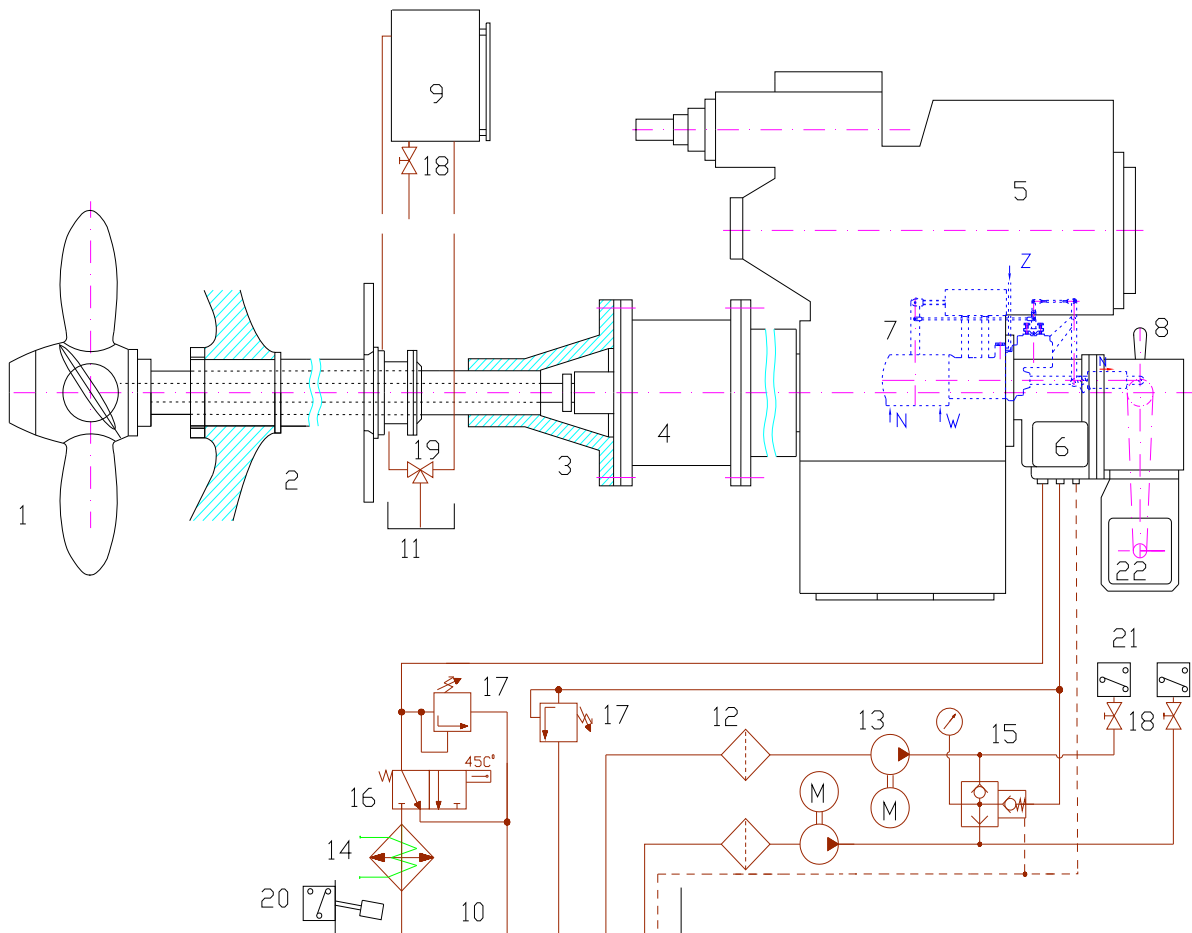

Fig. 1. Simplified drawing of the propulsion system with a scheme of the hydraulic part of the CPP control system

A hydraulic oil supply unit consists of a main tank 10 and two identical interchangeably worked subsystems. Each of these subsystems contains: suction filter 12, screw pump 13 driven by asynchronous electric motor, shut-off valve 18 and pressure relay 21. Both

subsystems are connected through a logical valve 15 and a check valve with a main line supplying oil to the directional control valve located in the oil distribution box which is presented more clearly on fig. 2. In case of significant pressure drop in the main oil conduit the second pump automatically starts to work simultaneously with varying signal. Oil returning from the directional control valve flows through thermostatic directional valve 16 to the water-oil cooler 14 or directly to the tank 10 depending on the oil temperature. Pressure relief valves 17 protected the main and return oil lines from excessive increase of pressure. In case of oil level drop to lower acceptable value a relay 22 turns on varying signal.

At the hydraulic oil system of the controllable pitch propeller there is also an additional stern tube oil lubrication unit. The unit consists of two oil tanks: gravitational tank 9 and discharge tank 11, three-way cock 19, shut-off valve 18 and tubes. Oil flows from the gravitational tank through the three-way cock into the stern tub bearings and the propeller hub. The tank 9 is located at a height of 3 - 4 m over the sea level with the aim of obtain an oil pressure value inside the hull higher than a hydrostatic pressure of the sea water outside. During inspections or repairs the oil from the gravitational system is drained into the discharge tank 11. Possible oil losses in this system are resupplied with use of additional oil line with check valve (not shown on fig. 1) connected to the main line supplying oil to the directional control valve. The shut-off valve 18 located under the gravitational tank 9 enables periodic inspection leaktightness of the system by draining a small quantity of oil from the bottom of the tank and checking if there is no water or other pollutants.

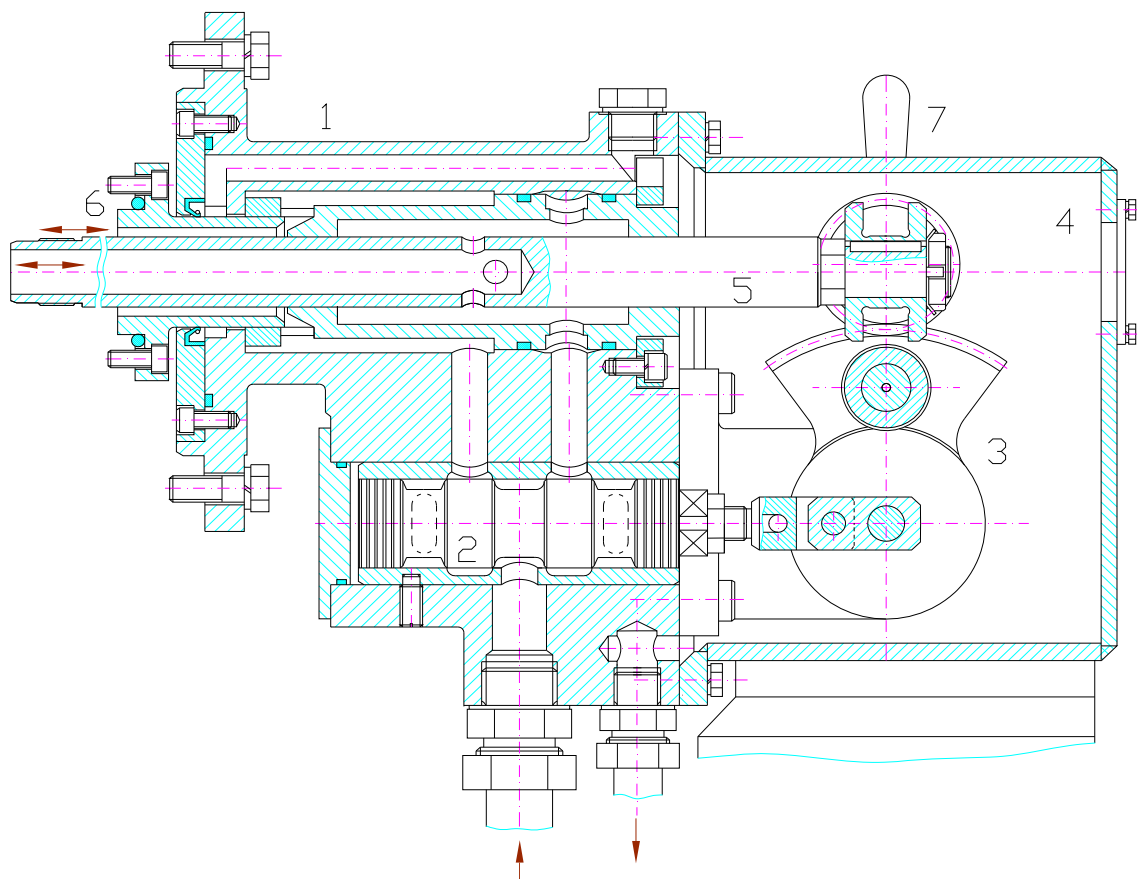

Fig. 2. Simplified drawing of the oil distribution box with visible directional control valve and the feedback mechanism

The oil distribution box is presented on fig. 2. A flange of a body 1 of the box is fixed to a front wall of a gear box (item 5 on fig. 1). The directional control valve 2 is in a lower part

of the body. The valve 2 is underlap version (in a central position oil flow from the supply to return line). Such kind of the valve 2 enables significant lightening of the pump during keeping up adjusted pitch of the propeller, especially in “full ahead” position. It should be mentioned that in the typical modern CP propellers the maximum loads of a servomotor, therefore also the highest oil pressure, appears during changing pitch of the propeller from “astern” to “ahead” direction when it passes the “0” position. Considering that the ship usually sails more than 95% of the time with the pitch adjusted to “full ahead or close to it, the pump works with the forcing oil pressure only a little higher than it is needed in the servomotor. It increases survivability and reliability of the pump as well as effectiveness of whole propulsion system.

Adjustment of the propeller pitch is realized by turning the lever 7. It can be done by using the pneumatic cylinder ((item 7 on fig. 1) and the pneumatic connector – in case of remote control or directly by hand. In both cases a steering signal from the lever 7 is carried through a unit 3 of shafts, wheels and levers to a control spoon of the directional control valve 2, causing its displacement. Displacement of the control spoon to the right causes the oil flow from the main supply line to the right outflow and next to an interior of the control rod 5, which passes through a coaxial hole of the output shaft of the gear. The aft end of the rod is connected to the piston of the servomotor (item 4 on fig. 1), so the oil flows into an aft chamber of the servomotor. Simultaneously the oil from the fore chamber flows out through a space outside the rod but inside the outer shaft and fixed to it sleeve 6 and next through a left channel to the directional control valve. From the valve the oil flows through channels drawing broken line to the return line (visible only on fig.1).

On the fore end of the rod there is fixed a sliding ring with a circumferential groove, in which is located a shoe attached in a revolving way to one of the feed back unit (3) lever. Displacement of the servomotor piston and the rod and sliding ring connected to it causes movement of the feed back unit elements and as a result displacement of the control spoon of the directional control valve in opposite direction then the piston. The movement lasts till a moment when a real value of the propeller pitch achieve an adjusted value in assumed accuracy.

The remote pneumatic control system of the controllable pitch propeller is presented in a simplified way on fig. 3. A setting lever 1, together with pressure signal relays 2 (for “ahead”) and 3 (for “astern”) are located in the wheeling room. After deflection of the lever 1 from a central position pressure signals from the relays run through a connecting valve 6 to the pneumatic servomotor 4. In result, a piston rod displaces and together with it moves also joined with it pneumatic connector 5, which causes deflection of the local control lever (item 8 on fig. 1). The pneumatic connector 5 serves as an elastic element, which characteristic depends on the supply air pressure. The connecting valve 6 together with a hydraulic – pneumatic transmitter 7 and main engine regulator 12 constitute automatic control system. The main aim of the system is protection of the main engine from overload by reduction of the propeller pitch value.

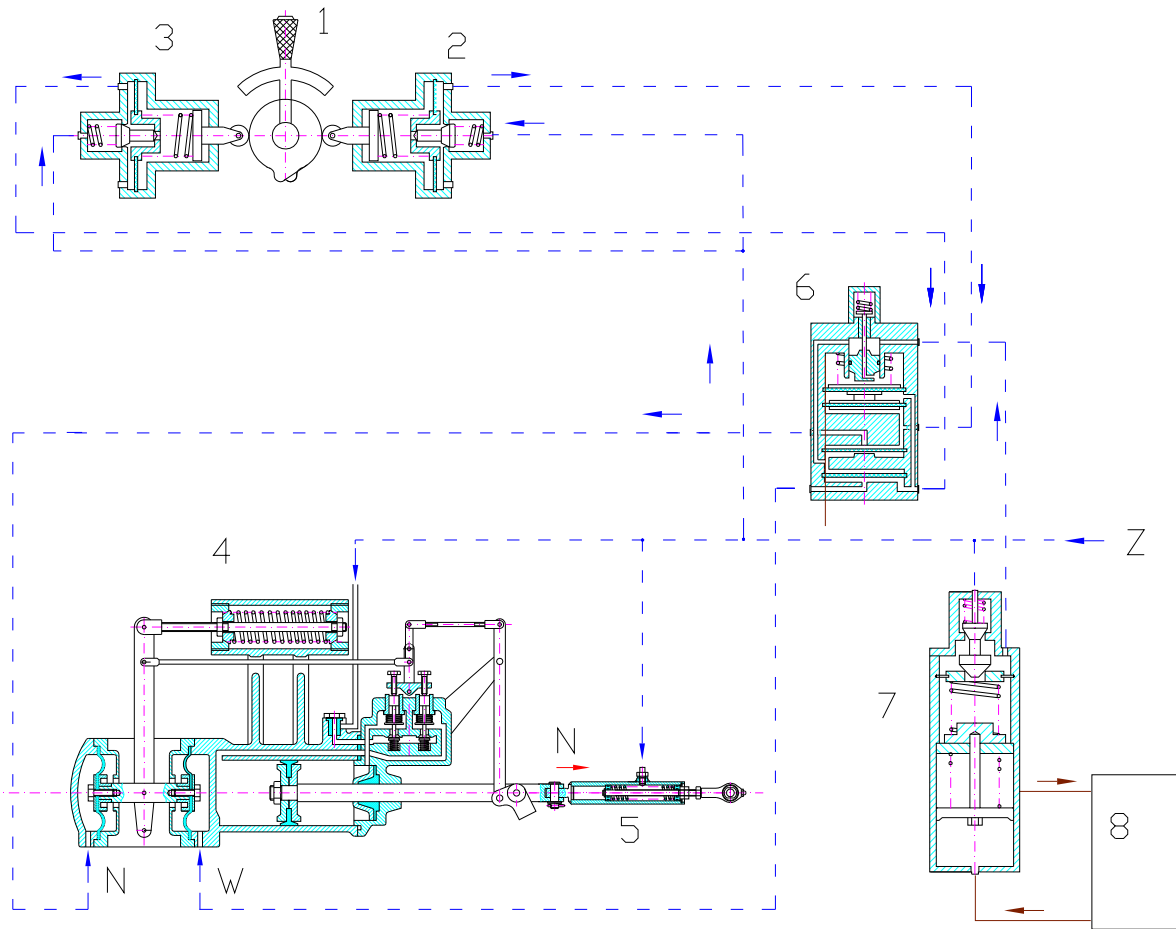

Fig. 3. A simplified drawing of the remote pneumatic control system of the controllable pitch propeller. Letter nomenclature: N – „ahead” direction, W – „astern” direction, Z – air supply.

The pneumatic servomotor is presented more clearly on fig. 4. The pneumatic pressure control signals run to intakes N and W of a double membrane cylinder 1, which a rod is connected by articulated joint with a lever 2. The lever 2 is connected in the same way with a body of the cylinder 1 at the lower end and with connectors 3 and 5 at the upper end. Movement of the rod causes a deflection of the lever 2 and displacement of the connectors 3 and 5. The connector 3 is attached to the pneumatic servomotor body through elastic preloaded element 4, what enables to cumulate the energy of the control signal for its bigger value. A right end of the connector 5 is joined with the lever 6 what causes its deflection relate to its axis of articulated joint with connecting link 7, and also deflection of a tri-armed lever 9, which controls action of a double valve 10. A lower chamber of a valve body is common for both valves and is connected with air supply pipe Z through an air filter 13. Two upper separate chambers of the valve body are individually connected with fore and back chambers of the main pneumatic cylinder 11. Deflection of the tri-armed lever 9 causes throttling air flow in one valve and simultaneously reliving in second. It resulted in diversifying of the pressure values on both sides of a pneumatic cylinder piston and its movement. The movement of the piston together with a piston rod 12 and connected with it a lower end of a lever 8 will last till a moment when an upper end of the lever 8 moving in opposite direction together with the connected link 7 and an upper end of the lever 6 cause returning movement of the lever 9 to a central position. Then the pressure in both chambers

will be equal and the piston will stop at a position adequate to an adjusted value of the propeller pitch.

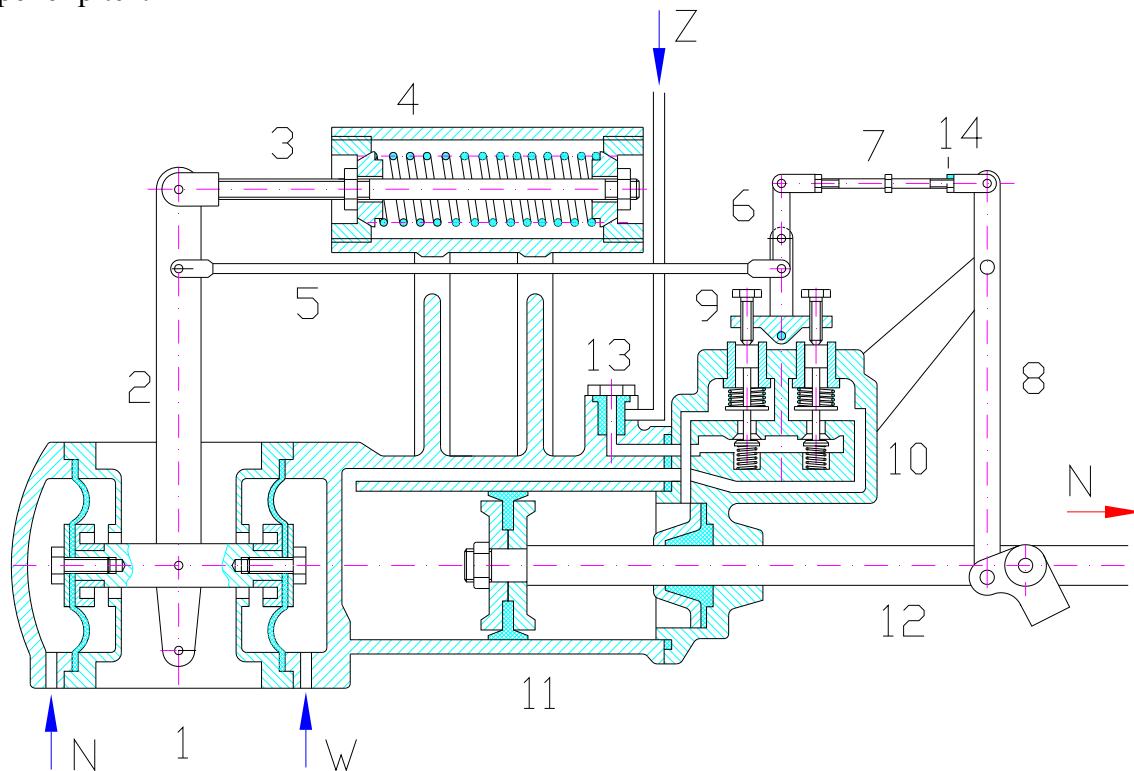

Fig. 4. A simplified drawing of the pneumatic servomotor of the controllable pitch propeller remote control system. Letter nomenclature: N – „ahead” direction, W – „astern” direction, Z – air supply.

3. Investing conduct of the collision’s cause

Two hours after collision during the engine room machinery inspection the ship’s engineer spotted the broken connecting link (item 7 on fig. 4). A break intersection was at a fore face plain of a left lock-nut, which is shown on fig. 5. No other damages were found.

Outside the air pipes connecting control desk in the wheel house with the engine room lying on interior side of a front wall of the ship superstructure were bended, similarly as the wall, but not broken. All following investigation works were conducted with knowledge and in presence of the author of the paper.

In the beginning, the testimony of the captain and the ship crew concerning collision circumstances and a technical documentation of the CPP propeller were analysed. Next in the CP propeller producer presence tested the CPP hydraulic control system. The main engine was switched off. During this test different values of the propeller pitch in a full range were set, with the local control lever (item 8 on fig.1). Simultaneously a diver kept underwater observation and checked correctness of this test results. The system worked correctly and nothing wrong was noticed.

The remote pneumatic control system without broken connecting link was also tested. Even by very light finger pushing on the upper end of the lever 6 (on fig.4) the piston rod 12 moved in one or another direction according to direction of finger pushing. In full range of control it worked correctly. During this test I have noticed one characteristic feature of the pneumatic servomotor. It was that from each set position of the piston rod after stopping pushing on lever 6, it automatically moved to “full ahead” position.

After one more analysis of the control system I have decided to conduct next test but of the completed system with mounted new connecting link, which basic significant dimensions

would be exactly the same as in the damaged one. Conformity of two most significant dimensions, namely a distance between outer surfaces of botch pins of connecting link and distance between the pin and face surface of the connecting link screw, which are shown on fig. 5, was checked in front of the commission.

The tests were conducted in a presents of the representatives of all interested sides. At the beginning a correctness of the CPP hydraulic control system operation was check with the use of the local setting lever. The propeller pitch was several times changed in a full range from one to second extreme positions, until relief valve opening. During this test the system worked correctly.

The following tests were conducted with using the remote pneumatic control system and checking conformity of the set values with real values of the propeller pitch during a few full cycles of the pitch changing. Also this time the system worked correctly. In this situation I have decided to repeat last test changing gradually, step by step the propeller pitch and each time observing and touching the connecting link 7, gently pressing it by finger. In almost all steps the pressing connector displaced slightly crosswise in a clearance range, but just in positions “full ahead” and close to it the connector tensed and stiffened. Precise observation of this connection unit revealed a reason of this stiffness. Just in mentioned above position close to „full ahead”, a face surface of the connector link screw rested against the lever 6 in such way, as is shown on fig. 5. Because of it, a bending moment in the screw was generated. This additional bending moment load was undoubtedly many times bigger than a nominal axial force load.

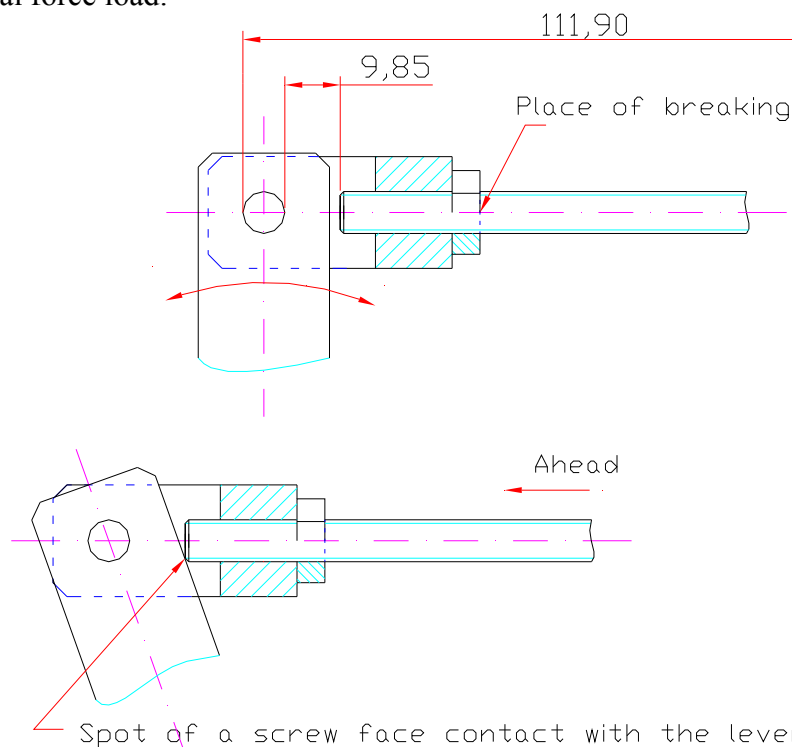

Fig. 5. An articulated joint of the connecting link with the lever in “zero” and “full ahead” positions with shown two dimensions checked in front of the commission

A test of the system reaction on a rapid disconnection of the connecting link 7 and lever 6 was conducted by pulling off the pin connecting both these elements, which simulated a break of the connecting link. The simulation was done for both extreme and a few intermediate pitch settings. Every time at a moment of disconnection of the system caused a change of the propeller pitch to “full ahead” position.

Apart from described works a metallographic examination of a broken screw surface was conducted at the Faculty of Ocean Engineering and Ship Technology of Gdansk University of Technology Laboratory. The results of the examination shown that the connecting link breaking was caused by material fatigue under influence of changing bending moment loads in a long period of time.

Photographs of the screw fatigue fracture with marked zones of conducting fatigue damages are presented on fig. 6. A fatigue crack was a result of acting in the first area a parallel but displaced in comparison with a screw axe force in long period of time, what generated a bending moment. This kind of load caused sequential “opening” and “closing the fatigue crack which propagated in the zone”2” direction. With the passage of time the crack was slowly increasing and after reaching the zone “2” the increase was successively faster because of a more significant decreasing of a loaded cross-section area and growing value of stresses. When the crack reached zone “3” about 60% of a screw cross-section area was lost and stresses excided strength of the material what caused final breaking

4. Final remarks

The above presented analytical works and inspections as well as the CPP control system tests and a metallographic examination of the fatigue fracture enabled to find a real reason of the collision. It was an incorrect adjustment of the feedback elements connection in the pneumatic servomotor unit. More precisely speaking the screw of the connecting link 7 was too deep screwed in the lug at the side of lever 6 (fig. 4 and fig. 5). Because of it, every time in the “full ahead” propeller pitch position the screw face contact with the lever occurred. It caused an additional load of the bending moment on both these elements. The moment was acting at a vertical surface of their movement. The effects of such loads were most unfortunate for this screw, because its cross-section area was the smallest and the thread was a significant notch. It should be marked that during the nominal work the load of the screw, that is – axial force being very small, about 1 N, the generated stresses could not cause such damage. But the additional periodic bending moment loads were multiply bigger and generated much higher stresses. Value of these stresses was lower than static strength so did not caused short term breaking, but repeating continuously in long period of time led to fatigue breaking. Mechanism of this kind of damage was explained in the metallographic examination of a broken screw surface report [1].

It is worth mention that there is conformity of the damage area propagation direction with the bending moment acting surface, what is noticeable on fig.6

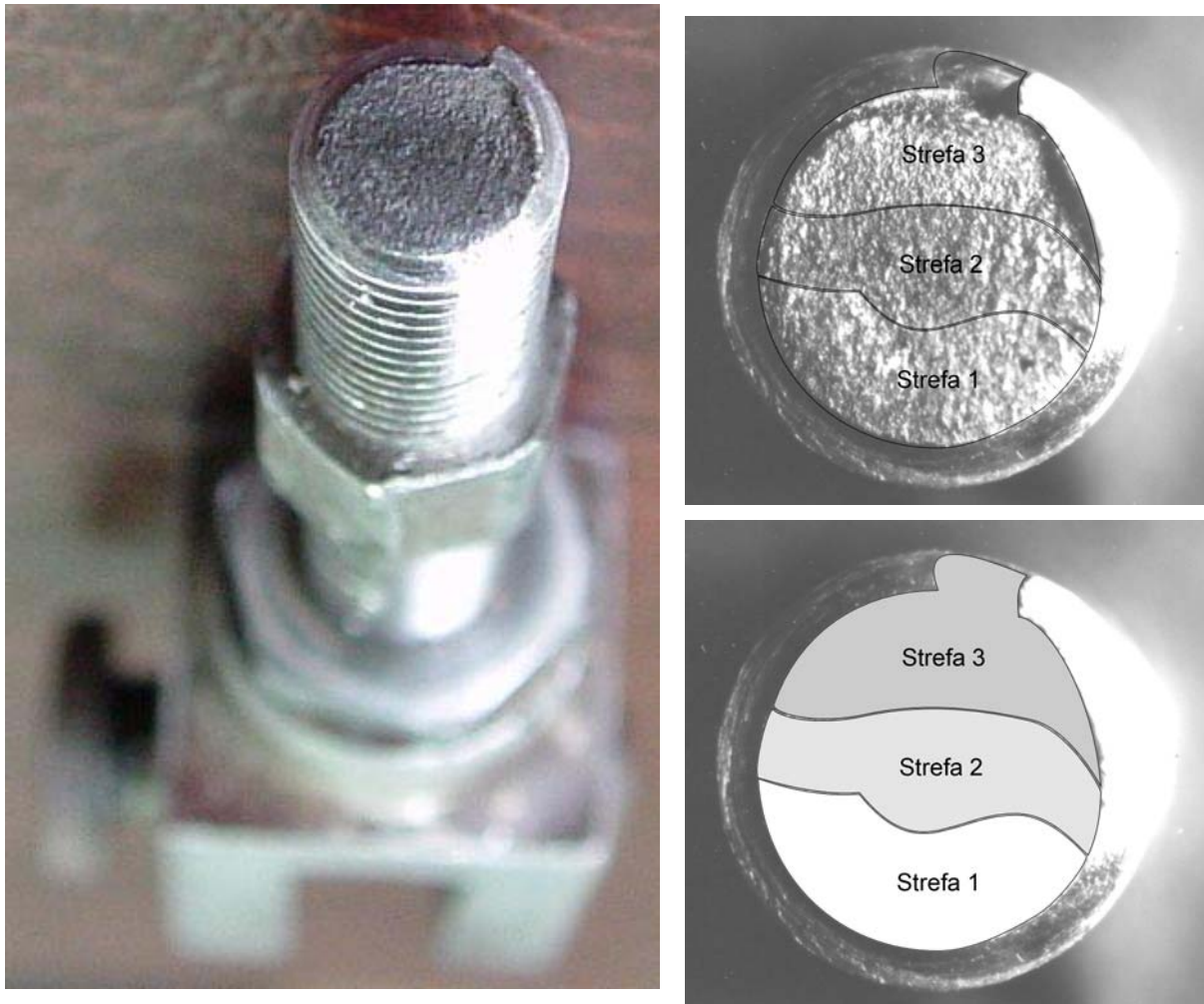

Fig. 3. A view of the fatigue fracture with marked zones of conducted fatigue damage

Apart from an explanation of the reason of the connecting link breaking it is worth to wonder when and in what circumstances the incorrect system regulation took place. Analysis of the technical period inspection report of the CPP control system, which was written a half of year before the collision, has shown that the length of the connecting link did not change and event did not disconnect this element. Only the correctness and precision of the CPP control system work in a full range of its operation was checked, especially in zero position. Because the system worked correctly and sufficiently accurately, which was confirmed during an investigation tests with the new connecting link, the service crew did not see a need to do a detailed inspection which could be done after dismantling the system elements. Probably the previous inspections were conducted in similar way, which explains such long period of the exploitation time, and propagation of the fatigue damage.

Essentials feature of the presented CPP remote control system was its incorrect adjustment contradictory to a rule widely accepted in engineering that damage of any control system or supply unit element should cause stoppage of the device or switching over on the most safe operation conditions. In this case a break of the connecting link should have caused a setting change rather to “full astern” than “full ahead”. It should be marked that modern CP propellers are made with a blade geometry designed in such a way to generate on its surface hydrodynamic forces and moments automatically causing the turning of the blade, from each actual pitch to “full astern” position. It is advantageous from two reasons. Firstly, in case of any failure the hydraulic control system and oil pressure drop the propeller pitch

automatically changes to “full astern” position, which causes decrease of the ship velocity. It enables to switch off the main engine at the proper moment and to stop the ship. Secondly, a constant direction of external load assures system operation with a slightly one-direction tensioned elements, which eliminates an influence of the any clearance and increases accuracy of the CPP control system.

I hope that presented description of the control system and analysis of the collision reasons might be a useful knowledge material, especially for designer and users of the control systems

Bibliography

1. Kozak J. Opinia na temat sposobu niszczenia łącznika. Prace badawcze Wydziału Oceanotechniki i Okrętownictwa.
2. Dokumentacja zdawcza śruby nastawnej produkcji Zakładów Mechanicznych ZAMECH w Elblągu