

Quantum superadditivity in linear optics networks: Sending bits via multiple-access Gaussian channels

Ł. Czekaj,^{1,2} J. K. Korbicz,^{1,2,3} R. W. Chhajlany,^{1,2,4} and P. Horodecki^{1,2}

¹*Faculty of Applied Physics and Mathematics, Gdańsk University of Technology, PL-80-952 Gdańsk, Poland*

²*National Quantum Information Center of Gdańsk, PL-81-824 Sopot, Poland*

³*Institute of Theoretical Physics and Astrophysics, University of Gdańsk, PL-80-952 Gdańsk, Poland*

⁴*Faculty of Physics, Adam Mickiewicz University, Umultowska 85, PL-61-614 Poznań, Poland*

(Received 13 May 2009; revised manuscript received 9 October 2009; published 31 August 2010)

Superadditivity effects of communication capacities are known in the case of discrete variable quantum channels. We describe the continuous variable analog of one of these effects in the framework of Gaussian multiple access channels (MACs). Classically, superadditivity-type effects are strongly restricted: For example, adding resources to one sender is never advantageous to other senders in sending their respective information to the receiver. We show that this rule can be surpassed using quantum resources, giving rise to a type of truly quantum superadditivity. This is illustrated here for two examples of experimentally feasible Gaussian MACs.

DOI: [10.1103/PhysRevA.82.020302](https://doi.org/10.1103/PhysRevA.82.020302)

PACS number(s): 03.67.Hk, 89.70.Kn

The study of the power of utilizing quantum resources for information-processing tasks is key to the field of quantum information [1,2]. Quantum resources can be harnessed to beat performance attainable in certain tasks by using only classical bit processing. In particular, certain impossible tasks under classical processing turn out to be possible using quantum resources. Apart from the analysis of single resources, a fundamental question is whether the quantum parallel use of two or more resources is better than their separate use for certain tasks.

Entanglement catalysis [3] for the transformation of one pure state into another pure state attainable by adding a fixed entangled resource was the first example of such a superadditivity effect in the pure-state domain. In the mixed-state scenario, the first superadditivity effect consisted of the activation of bound entanglement [4] using free, weakly entangled states. An even more striking effect was shown to exist in the multipartite case where pure-state entanglement can be distilled from different types of bound entanglement [5]. In the context of communication theory, quantum channel capacity was shown to be superadditive in a multisender-multireceiver scenario where two-way unlimited classical communication can be used [6]. The strongest version of superadditivity of quantum capacity between a single sender and receiver without access to classical communication was recently proved by Yard and Smith [7]. Recently, an analogous effect has been proved for the so-called private capacity in the one-sender–one receiver scenario [8,9]. The question of superadditivity of classical capacity of quantum channels is open, although certain milestone steps have been made [10]. In the case of multiple access channels (MACs), however, it has been shown [11] that entangled encodings allow one to break the additivity of classical capacity regions. This result has been recently generalized to both quantum and classical capacities when one of the used channels is entanglement breaking [12].

All the results up to date pertain to the case of discrete variables. Here we address the question of additivity of classical capacity of continuous variable MACs (see [13]) and present two simple schemes involving Gaussian channels which exhibit an analog of the superadditivity effect of

Ref. [11]. Importantly, these schemes may be realized in the near future, as they may require as little as 6 dB of squeezing. One of these schemes based on a beam-splitter channel is directly related to standard fiber coupler theory [14] and is a natural formalism for optical networks [15].

We consider Gaussian MACs with two senders and one receiver. Classical Gaussian MACs (see [16]) are characterized by a locality rule: That is, increasing local resources of one sender (e.g., by providing the sender with more power or a new connection to the receiver) can never increase the maximal transmission rate of another sender.

This rule can be beaten in *quantum* Gaussian MACs. In a single-channel scenario, one sender may use all the energy at his disposal to produce a highly squeezed vacuum state, that is, a quantum resource, which is constantly fed into his input. This squeezing (quantum noise reduction) allows the other user to achieve a higher transmission rate (which depends on the squeezing level) than classically possible (see [17] for details), violating the dependence of individual rates only on individual power resources.

However this is not the sought-after superadditivity in a communication scheme. In general this effect takes place if and only if we have *two* channels Φ and Ψ that satisfy the superadditivity condition:

$$I_{A_k \rightarrow B}(\Phi \otimes \Psi) > I_{A_k \rightarrow B}(\Phi) + I_{A_k \rightarrow B}(\Psi). \quad (1)$$

Here I denotes the transmission rate or maximal mutual information between the sender A_k and receiver B . We show in the following the possibility of fulfilling this relation, thus also beating the achievable rates described in the previous paragraph. In the presented schemes, two channels, that is, a two-to-one MAC Φ and a one-to-one identity channel Ψ provided only to one user, are used in parallel to communicate to a common receiver.

The first scheme [see Fig. 1(a)] consists of a beam-splitter MAC $\Phi : A_1 A_2 \rightarrow B$ with only one output mode B , that is, $\Phi(\varrho_1 \otimes \varrho_2) = \text{tr}_1(U_{BS} \varrho_1 \otimes \varrho_2 U_{BS}^\dagger)$, where $U_{BS} = \exp[i\theta(a_1^\dagger a_2 + a_1 a_2^\dagger)]$. The transmittivity of the device is $\tau = \cos^2 \theta$. The first (second) user accesses only one arm

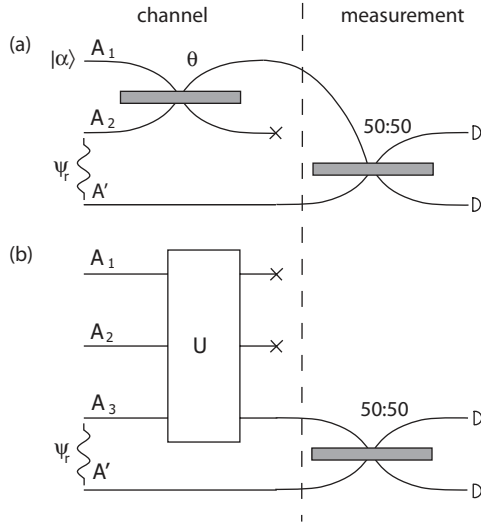

FIG. 1. Two schemes for entanglement-assisted single-user classical capacity superadditivity based on (a) a beam-splitter MAC and (b) a triple quantum nondemolition sum gate MAC. The quantity of interest is the capacity attainable by the top sender.

$A_1(A_2)$ of this MAC. The second user has sole access to $\Psi : A' \rightarrow B'$.

We choose an entanglement-assisted (EA) transmission scheme where the lower sender always inputs a two-mode squeezed vacuum state containing no information into A_2A' :

$$|\psi_r\rangle = \exp[r(a_2^\dagger a'^\dagger - a_2 a')] |00\rangle. \quad (2)$$

The messages are encoded by the upper user in coherent states $|\alpha\rangle$ [18]. The receiver decodes these messages by mixing the two signals output from both channels at a 50:50 beam-splitter and performing homodyne measurements on the mixed signals. Note that, inputting a strong coherent state to one arm A_1 of an almost perfectly transmitting beam-splitter effectively displaces the state input at the other arm A_2 , that is, $\Phi(|\alpha\rangle\langle\alpha| \otimes \rho_2) \rightarrow D(\alpha \sin \theta) \rho_2 D(\alpha \sin \theta)^\dagger$ when $\theta \rightarrow 0$, $|\alpha| \rightarrow \infty$, $|\alpha| \sin \theta \rightarrow \text{constant}$, as shown in [19]. Thus, in this limit, the displacement modulates half of the entangled state used here and we obtain dense coding of the messages, through our scheme.

By assuming a Gaussian probability distribution for the messages α (see [13,20]),

$$p_0(\alpha) = \frac{1}{\pi \sigma^2} e^{-\frac{|\alpha|^2}{\sigma^2}}, \quad (3)$$

the mutual information of A_1 and BB' is

$$I(A_1 : BB') = \log \left[1 + \frac{\sigma^2 \sin^2 \theta}{(\cosh r - \cos \theta \sinh r)^2} \right]. \quad (4)$$

This reproduces the dense coding formula in the limit $\theta \rightarrow 0$, $\sigma \rightarrow \infty$, $\sigma \sin \theta = \text{constant}$ [21], as expected: $I \rightarrow \log(1 + e^{2r} \sigma^2 \sin^2 \theta)$, with an effective dispersion σ^2 multiplied by the beam-splitter reflectivity $\sin^2 \theta$.

We maximize Eq. (4) under power (average photon number) constraints \mathcal{P} for the two users:

$$\{\text{upper sender power}\} = \sigma^2 \leq N_1, \quad (5)$$

$$\{\text{lower sender power}\} = 2 \sinh^2 r \leq 2N_2. \quad (6)$$

The *unconstrained* maxima of I of (4) are located at

$$\cos \theta = \tanh r. \quad (7)$$

The constraint (6) leads to two cases: $\cos^2 \theta \leq N_2/(N_2 + 1)$ and $\cos^2 \theta > N_2/(N_2 + 1)$. We will study only the first case now [22]. Then the constrained maximum of I is attained at (7) and $\sigma^2 = N_1$:

$$I_{\max}^{\text{ent}} = \log(1 + N_1). \quad (8)$$

The matching condition (7), connecting the signal parameter (squeezing r) to the device parameter (transmittivity $\cos^2 \theta$), eliminates the explicit dependence of I_{\max}^{ent} on N_2 or θ . Note that I_{\max}^{ent} scales only as $\log N$ instead of the expected $\log N^2$ for ideal dense coding [13] due to the highly lossy nature of the channel in the high-transmittivity (i.e., dense coding) limit.

We are interested in whether the EA scheme leads to enhancement of capacity with respect to the case where no entanglement is used. We therefore bound the optimal capacity I_{\max}^{prod} attainable using any entanglement-free encoding schemes (i.e., not necessarily using Gaussian states) restricted only by the same energy constraints on each sender as used earlier. Without entanglement, the identity channel is of no direct use to the upper sender, so the quantity of interest is only the MAC capacity. The total rate of this channel $R_1 + R_2 \leq \max_{\rho_1 \otimes \rho_2} S(\Phi(\rho_1 \otimes \rho_2))$ is bounded by the maximal possible output entropy by Holevo's theorem [23]. Using the extremality property of Gaussian states, this entropy is maximized by some Gaussian state for bosonic systems (see [24]). In particular, therefore, we obtain for the capacity of the first user

$$I_{\max}^{\text{prod}} \leq g(N_{\max}), \quad (9)$$

where $g(x) = (1+x) \log(1+x) - x \log(x)$ is the single-mode Gaussian entropy and N_{\max} is the maximal number of output photons (see [25]).

For a given beam-splitter channel,

$$N_{\max} = N_{\max}(\theta) = N_1 \sin^2 \theta + 2N_2 \cos^2 \theta \quad (10)$$

under the constraints (5) and (6). The bound Eq. (9) in this case can be achieved, if the lower user sends no information ($R_2 = 0$), inputting instead a squeezed vacuum utilizing all his available energy, $2N_2$ [17].

To simply show the possibility of superadditivity, consider MACs with high transmittivity, where quantum effects are most prominent in the EA protocol. Under (6), the largest transmittivity is (cf. [26])

$$\cos^2 \theta = \frac{N_2}{N_2 + 1}. \quad (11)$$

For such a beam-splitter $N_{\max} = [N_1 + 2(N_2)^2]/(N_2 + 1)$ determines I_{\max}^{prod} . For comparison with the EA scheme, assume the worst case scenario [i.e., equality in Eq. (9)]. Now, the ratio $I_{\max}^{\text{ent}}/I_{\max}^{\text{prod}}$ is maximized by the condition $N_1 = 2N_2(N_2 + 2)$,

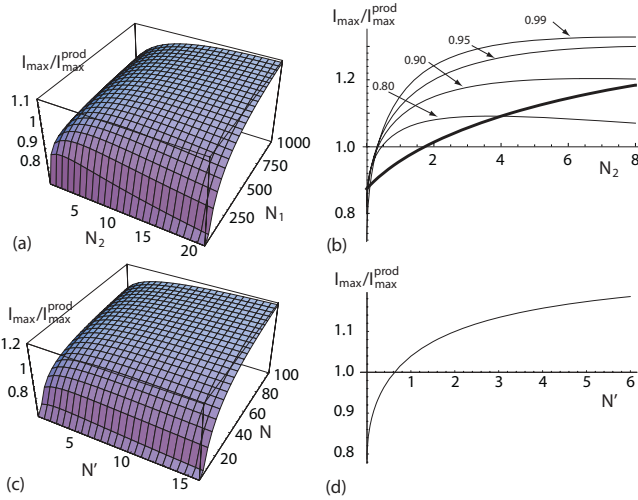

FIG. 2. (Color online) Ratios of the classical capacities of entanglement-assisted channels and regularized capacities of the same channels with product inputs as functions of the power constraints for (a) the beam-splitter channel of Fig. 1(a), (b) the cut for $N_1 = 1000$; and (c) the triple QND sum gate channel of Fig. 1(b), (d) the cut for $N = 100$. In (b), the bold line depicts results obtained using condition (7), while the other lines are results for exemplary beam-splitters with transmittivities of 80%, 90%, 94%, and 98%. The break-even squeezing values for these beam-splitters are 6.34, 5.73, 5.79, and 7.69 dB, respectively.

leading to $N_{\max} = 4N_2$. The maximum value of this parameter is therefore $\log[1 + 2N_2(N_2 + 2)]/g(4N_2)$, which is easily seen to surpass unity for large enough N_2 , indeed proving quantum superadditivity. In particular, $I_{\max}^{\text{ent}}/I_{\max}^{\text{prod}}$ approaches 2 as $N_2 \rightarrow \infty$.

More generally, ramping up the local input powers leads to superadditivity [Fig. 2(a)]. For example, Fig. 2(b) shows the capacity enhancement for the a modest input power $N_1 = 1000$. Note that each point in the figure corresponds to a distinct physical channel—different N_2 's correspond via Eq. (11) to different beam-splitters. Superadditivity appears for $N_2 \geq 1.73$, corresponding to a squeezing $r \geq 9.46$ dB of the lower sender's signal state.

It is interesting practically to consider the time of onset of superadditivity for beam-splitters of given transmittivities, in particular whether this occurs at lower squeezing than just described. Consider therefore the ratio of EA capacity (see Eq. (4) and [22]) to product input capacity, away from the curve (7) (treating the beam-splitter parameter θ as an independent parameter now) under the constraints (5) and (6) as the power N_2 is increased. By choosing a reasonable value of $N_1 = 1000$, superadditivity effects appear [see Fig. 2(b)] for beam-splitters characterized by small yet finite reflectivity for squeezing in the range 5.7–7.7 dB, which is very close to values routinely obtained in laboratories.

Our second example [Fig. 1(b)] consists of the Gaussian MAC channel $\Phi : A_1A_2A_3 \rightarrow B$ defined by $\Phi(\varrho_{12} \otimes \varrho_3) = \text{tr}_{12}(U\varrho_{12} \otimes \varrho_3U^\dagger)$, where

$$U = \exp[-i(\hat{x}_1\hat{p}_3 - \hat{p}_2\hat{x}_3)]. \quad (12)$$

This unitary is generated by two quantum nondemolition (QND) type interactions and can be decomposed into three

QND sum gates [27] among modes 1, 2, and 3. The upper sender holds both lines A_1 and A_2 , while the lower one holds lines A_3 and A' of channel Ψ .

The EA transmission protocol is the following. The upper sender encodes a message $\alpha = \alpha_R + i\alpha_I$ into the displaced state: $|\psi_{\text{in}}\rangle_{A_1A_2} = D(\alpha_R, 0)|R\rangle \otimes D(0, \alpha_I)|-R\rangle$, where $|\pm R\rangle$ are single-mode squeezed vacuum states with squeezing parameters $\pm R$. For large squeezing $R \rightarrow \infty$, the action of Φ again approaches the displacement $D(\alpha)$. Just as before, we assume that (i) the lower sender always sends a two-mode squeezed state ψ_r , cf. Eq. (2), on the lines A_3A' ; (ii) the input probability $p_0(\alpha)$ is given by Eq. (3); and (iii) the decoding is done through homodyne detection on the output lines BB' (see Fig. 1).

The mutual information between the upper sender A_1A_2 and the receiver BB' is

$$I(A_1A_2 : BB') = \log \left[1 + \frac{\sigma^2}{e^{-2r} + (e^{-2R}/2)} \right]. \quad (13)$$

As expected, in the limit $R \rightarrow \infty$ we again recover the continuous variable dense coding capacity [21]. We apply similar photon number constraints \mathcal{P} as before in Eqs. (5) and (6):

$$\{\text{upper sender power}\} = \sigma^2 + 2\sinh^2 R \leq N, \quad (14)$$

$$\{\text{lower sender power}\} = 2\sinh^2 r \leq 2N'. \quad (15)$$

The constrained maximum of I of Eq. (13) is achieved when the inequalities (14) and (15) are saturated: $\sinh^2 r = N'$ and $\sigma^2 = N - 2\sinh^2 R$, the latter leading through maximization of Eq. (13) to $2e^{2R} = -e^{2r} + \sqrt{e^{4r} + 4e^{2r}(N+1)} + 4$. Substituting into (13) yields the desired maximum achievable one-shot rate I_{\max}^{ent} .

Using the same argument as in the previous scheme, we compare I_{\max}^{ent} with the capacity of Φ with product input states. By analogous calculation, it is bounded by Eq. (9) (see [25]) with

$$N_{\max} = \left(\sqrt{2N' + \frac{1}{2}} + \sqrt{N+1} \right)^2 - \frac{1}{2}, \quad (16)$$

which, due to the quadratic character of the channel [see (12)], is the maximum output number of photons. This bound follows directly from the input-output relations for the MAC (12) and constraints (14) and (15) for product inputs in the cut $A_1A_2|A_3$. Regions of superadditivity are manifest in the plot of $I_{\max}^{\text{ent}}/I_{\max}^{\text{prod}}$ in Fig. 2(c). Figure 2(d) shows the cut for $N = 100$ [cf. Eq. (14)]. Quantum superadditivity occurs for power $N' \geq 0.63$ or 6.33 dB of two-mode squeezing while the upper sender uses 4.21 photons in each line requiring single-mode squeezing of 12.73 dB. In the end of the range, that is, $N' = 6$ (noise reduction of 14.15 dB) the upper sender uses at most 9.45 photons per line or 16.02 dB.

We have shown capacity superadditivity in Gaussian MAC channels, which has no classical analog. Finally, we comment on perspectives for implementation of proof-of-principle experiments of these effects. The first scheme consists of an extremely basic linear optics setup, while a QND sum gate has also been implemented [28]. The main obstacle for observation of superadditivity effects is the amount of squeezing required. However, recently, techniques yielding squeezing of up to 10 dB have been reported, with 15 dB being claimed attainable in the near future [29]. Such parameters

are sufficient for manifestation of superadditivity as shown in this Rapid Communication. Indeed squeezing above 5.7 dB suffices to observe this effect using a beam-splitter with 90% transmittivity.

We thank M. Horodecki and R. Horodecki for discussions and the EU integrated project SCALA for financial support. RWC gratefully acknowledges support from the Foundation for Polish Science (FNP).

- [1] M. Nielsen and I. Chuang, *Quantum Computation and Quantum Information* (Cambridge University Press, Cambridge, UK, 2000).
- [2] C. H. Bennett, D. P. Di Vincenzo, J. A. Smolin, and W. K. Wootters, *Phys. Rev. A* **54**, 3824 (1996); H. Barnum, M. A. Nielsen, and B. Schumacher, *ibid.* **57**, 4153 (1998).
- [3] D. Jonathan and M. B. Plenio, *Phys. Rev. Lett.* **83**, 3566 (1999).
- [4] P. Horodecki, M. Horodecki, and R. Horodecki, *Phys. Rev. Lett.* **82**, 1056 (1999).
- [5] P. Shor, J. A. Smolin, and A. V. Thapliyal, *Phys. Rev. Lett.* **90**, 107901 (2003).
- [6] W. Dür, J. I. Cirac, and P. Horodecki, *Phys. Rev. Lett.* **93**, 020503 (2004).
- [7] G. Yard and J. Smith, *Science* **321**, 1812 (2008).
- [8] K. Li *et al.*, e-print [arXiv:0903.4308](https://arxiv.org/abs/0903.4308).
- [9] G. Smith and J. A. Smolin, *Phys. Rev. Lett.* **102**, 010501 (2009); **103**, 120503 (2009).
- [10] M. B. Hastings, *Nature Phys.* **5**, 255 (2009).
- [11] Ł. Czekaj and P. Horodecki, *Phys. Rev. Lett.* **102**, 110505 (2009).
- [12] A. Grudka and P. Horodecki, *Phys. Rev. A* **81**, 060305 (2010).
- [13] S. L. Braunstein and P. van Loock, *Rev. Mod. Phys.* **77**, 513 (2005).
- [14] A. A. El-Fadl, G. E. Elabiad, S. M. Eladl, and M. S. I. Rageh, presented at 16th National Radio Science Conference, Ain Shams University, 1999, Cairo, Egypt.
- [15] J. M. Myers, e-print [arXiv:quant-ph/0411107](https://arxiv.org/abs/quant-ph/0411107); e-print [arXiv:quant-ph/0411108](https://arxiv.org/abs/quant-ph/0411108).
- [16] T. M. Cover and J. M. Thomas, *Elements of Information Theory* (Wiley, New York, 1991).
- [17] B. J. Yen and J. H. Shapiro, *Phys. Rev. A* **72**, 062312 (2005).
- [18] The classical messages are assumed as complex numbers. Coherent states form the simplest implementable alphabet for continuous variable communication and are used in the EA schemes here as they are sufficient for proving superadditivity.
- [19] M. G. A. Paris, *Phys. Lett. A* **217**, 78 (1996).
- [20] Y. Yamamoto and H. A. Haus, *Rev. Mod. Phys.* **58**, 1001 (1986).
- [21] M. Ban, *J. Opt. B* **1**, L9 (1999); S. L. Braunstein and H. J. Kimble, *Phys. Rev. A* **61**, 042302 (2000).
- [22] In the second case, the maxima (7) lie outside the region [(5) and (6)], so that the constrained maximum of I is simply attained for $\sinh^2 r = N_2$ and $\sigma^2 = N_1$: $I_{\max}^{\text{ent}} = \log[1 + N_1 \sin^2 \theta / 2(\sqrt{N_2 + 1} - \cos \theta \sqrt{N_2})^2]$. This is applicable when we consider how the capacity changes by ramping the power N_2 from zero upward, for a given transmittivity.
- [23] A. S. Holevo, *IEEE Trans. Inf. Theory* **44**, 269 (1998).
- [24] A. S. Holevo, M. Sohma, and O. Hirota, *Phys. Rev. A* **59**, 1820 (1999).
- [25] This discussion is common to both MACs considered here [Figs. 1(a) and 1(b)]. The provided relation (9) is a true bound for the full capacity of both quantum MACs discussed here; i.e., it also holds under regularization. The regularization of a quantity $I(\Phi)$ is $\mathcal{I} = \lim_{n \rightarrow \infty} (1/n)I(\Phi^{\otimes n})$ and may increase capacity regions due to entanglement between copies. To see that this does not occur consider n copies of Φ under additive power constraints (i.e., each user now has a power constraint that is n times that available for a single channel). Once again using extremality of Gaussian states, one has that $\max_{\rho_1 \otimes \rho_2} S(\Phi^{\otimes n}) = S\{\varrho_G[N_{\text{out}}(\Phi^{\otimes n})]\} \leq \sum_k S[\varrho_G^{(k)}(N_{\text{out}}^{(k)})]$, for some n -mode Gaussian state ϱ_G with a total of $N_{\text{out}}(\Phi^{\otimes n})$ photons. The inequality bound is due to the subadditivity of entropy, where $\varrho_G^{(k)}$ is the reduced state of the k th copy with $N_{\text{out}}^{(k)}$ photons. For both MACs used here, the maximum output photon number is easily seen to be n times the maximum output for a single channel. The right-hand side of the inequality is maximized by distributing this energy equally over the n output states, thus yielding $(1/n) \max_{\varrho_1 \otimes \varrho_2} S(\Phi^{\otimes n}) \leq g[N_{\max}(\theta)]$.
- [26] It is enough to find *some* θ , for which $I_{\max}^{\text{ent}} \geq I_{\max}^{\text{prod}}$.
- [27] S. D. Bartlett, B. C. Sanders, S. L. Braunstein, and K. Nemoto, *Phys. Rev. Lett.* **88**, 097904 (2002).
- [28] J. Yoshikawa *et al.*, *Phys. Rev. Lett.* **101**, 250501 (2008).
- [29] Y. Takeno *et al.*, *Opt. Express* **15**, 4321 (2007); H. Vahlbruch *et al.*, *Phys. Rev. Lett.* **100**, 033602 (2008).

