

A SPICE EQUIVALENT CIRCUIT FOR MODELING THE PERFORMANCE OF DUAL FREQUENCY ECHO-SOUNDER

MAREK MOSZYNSKI, WALDEMAR LIS

Gdansk University of Technology
11/12, G. Narutowicza St., 80-233 Gdansk, Poland
marmo@eti.pg.gda.pl, wall@eti.pg.gda.pl

The paper presents novel network equivalent circuit of piezoceramic circular disc transducer that takes into account thickness and radial mode of vibrations. The starting point of the analysis is 4-port description of circular disc element representing the solution of wave equation set in radial and thickness directions. The approximate solution for harmonic case is represented in the form of 4x4 matrix, which is synthesized and implemented in circuit analysis software. The network is extended with acoustical port that allows for pressure calculations in the similar manner as when measuring echo-sounder transmitting and receiving parameters. The model is especially useful for simulating complete electronic circuit of dual frequency echo-sounders based on single circular disc transducer.

INTRODUCTION

The central part of an echo-sounder is the piezoelectric transducer. It is also widely used as the active element of other underwater inspection systems and ultrasonic devices. The problem of modeling vibration of piezoelectric transducers is well recognized in the literature. The number of authors have proposed different modifications of the equivalent circuit model of piezoelectric ceramic element vibrating in thickness mode as proposed by Mason in his early works in 1948. They include additional elements in the form of complex coefficients that allow modeling some observed in measurement effects, that maybe interpreted as dielectric, electro-mechanical and mechanical losses. Recently, due to numerical implementations of partial differential equations solvers it is relatively easy to model vibrations of transducer composed from any number of piezoelectric elements by finite element methods. However, there is still a need to have relatively simple model of piezoelectric transducer that could simulate internal workings of typical echo-sounder when one circular disc ceramic is used for dual-frequency operation using thickness and radial modes of vibration.

1. EXCERPT FROM THEORY OF PIEZOCERAMIC ELEMENT VIBRATIONS

The mathematical modeling of piezoelectric element properties along with comparison to laboratory measurements was the main topic of large amount of literature papers. The excellent overview with critic of different approaches could be found in [1]. The general formulation for circular cylindrical shells is presented in cylindrical coordinates using element mechanical displacement $u = (u_r, u_\theta, u_z)$ and stress $T = (T_{rr}, T_{\theta\theta}, T_{zz}, T_{rz}, T_{\theta z}, T_{r\theta})$ [2]. It leads to partial differential set of equilibrium equations combined with a set of piezoelectric constitutive equation set that links stress T and electric field $E = (E_r, E_\theta, E_z)$ with a strain $S = (S_{rr}, S_{\theta\theta}, S_{zz}, S_{rz}, S_{\theta z}, S_{r\theta})$ and electric displacement $D = (D_r, D_\theta, D_z)$ by the matrices of elastic stiffness coefficients c_{ij}^D , piezoelectric constants h_{ij} and dielectric permittivity coefficients ε_{ij}^S . Observed quantities are forces (mechanical and electric) and they represent surface integrals of field quantities. Virtually, the formulation could be expressed using other mechanical quantities i.e. forces F and surface velocities \dot{u} and electrical quantities i.e. voltage potential across transducer surfaces V and driving current I .

The analytical solution of such equation set is possible only due to certain assumptions that describe boundary conditions when piezoceramic element is forced to certain vibrations [3] and mounted in the housing. The approximate solution as presented for circular disc with radius a and thickness l in [4] assumes that two coordinate axes r and z are pure mode propagation directions i.e. $u_r = u_r(r)$ and $u_z = u_z(z)$. For harmonic driving signals with an angular frequency ω the force $F = (F_1, F_2, F_3)$ acting on side, back and front part of element (combined into a vector with voltage V) depend on velocity amplitudes $\dot{u} = (u_1, u_2, u_3)$ respectively (combined with electric current I). It can be expressed in a matrix equation:

$$\begin{bmatrix} F_1 \\ F_2 \\ F_3 \\ V \end{bmatrix} = \begin{bmatrix} \frac{Z_1 J_0(\omega a/v_1)}{j} & \frac{2\pi l(c_{11}^D - c_{12}^D)}{j\omega} & \frac{2\pi a c_{13}^D}{j\omega} & \frac{2\pi a c_{13}^D}{j\omega} & \frac{2lh_{31}}{j\omega a} \\ \frac{2\pi a c_{13}^D}{j\omega} & \frac{Z_3}{\tanh(j\omega l/v_3)} & \frac{Z_3}{\sinh(j\omega l/v_3)} & \frac{Z_3}{\sinh(j\omega l/v_3)} & \frac{h_{33}}{j\omega} \\ \frac{2\pi a c_{13}^D}{j\omega} & \frac{Z_3}{\sinh(j\omega l/v_3)} & \frac{Z_3}{\tanh(j\omega l/v_3)} & \frac{Z_3}{\tanh(j\omega l/v_3)} & \frac{h_{33}}{j\omega} \\ \frac{2lh_{31}}{j\omega a} & \frac{h_{33}}{j\omega} & \frac{h_{33}}{j\omega} & \frac{h_{33}}{j\omega} & \frac{l}{j\omega \varepsilon_{33}^S \pi a^2} \end{bmatrix} \begin{bmatrix} u_1 \\ u_2 \\ u_3 \\ I \end{bmatrix} \quad (1)$$

where J_0 and J_1 are zero and first order Bessel functions of the first kind, \sinh and \tanh are hyperbolic functions, $v_1 = \sqrt{c_{11}^D/\rho}$ and $v_3 = \sqrt{c_{33}^D/\rho}$ are wave velocities in r and z directions and $Z_1 = 2\pi a l \rho v_1$ and $Z_3 = \pi a^2 \rho v_3$ are piezoceramic acoustic impedances along those directions. It is worth to note that although practically the vibrations in z direction are of the most interest, these vibrations are coupled with vibration in r direction as all matrix elements are non zero. Thus, the piezoceramic element could be treated as a 4-port network. When a transducer operates in an echo-sounder, its active front part is loaded with acoustic impedance of the water i.e. $F_3 = -Z_F u_3 = -\pi a^2 Z_w u_3$, which is typically matched with acoustic window (for example made from urethane). Back part and side part are passive and embedded in acoustically soft material (for example cork). Then $F_2 = -Z_B u_2 = -\pi a^2 \rho_c c_c u_2$ and $F_1 = -Z_S u_1 = -2\pi a l \rho_c c_c u_1$. When the element is driven by hypothetical voltage V its solution could be obtained by simple matrix inversion:

$$\begin{bmatrix} u_1 \\ u_2 \\ u_3 \\ I \end{bmatrix} = \left([Z] + \begin{bmatrix} Z_S & 0 & 0 & 0 \\ 0 & Z_B & 0 & 0 \\ 0 & 0 & Z_F & 0 \\ 0 & 0 & 0 & 0 \end{bmatrix} \right)^{-1} \begin{bmatrix} 0 \\ 0 \\ 0 \\ V \end{bmatrix} \quad (2)$$

where $[Z]$ is 4x4 matrix from Eq.1. Fig.1 shows the solution as obtained using Eq.2 for piezoceramic circular disc made from PZT-5 with radius 22mm and thickness 10mm. For comparison purposes the solution as obtained for thickness mode only is also presented.

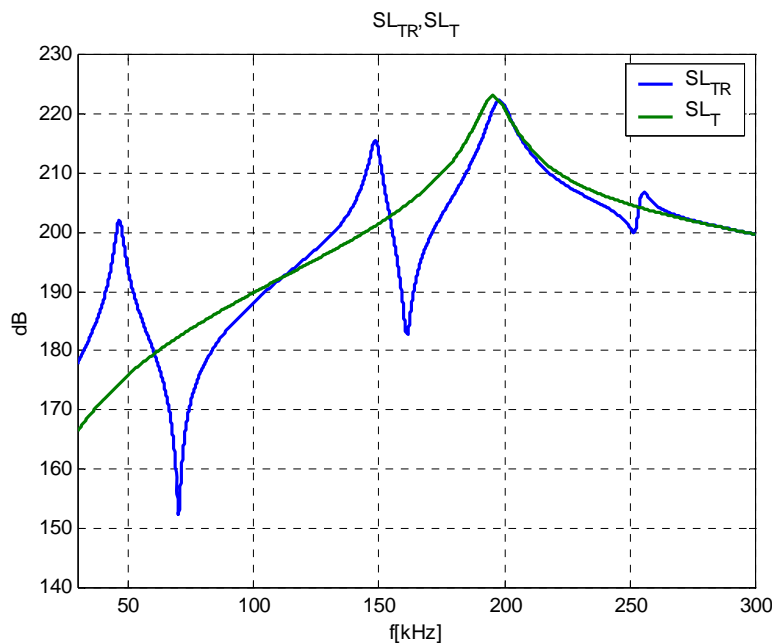

Fig. 1. Calculated Source Level of hypothetical dual-frequency echo-sounder designed for 50kHz and 200kHz operation with circular piezoceramic disc transducer driven by $1000V_{pp}$. Thickness and radial modes solution – SL_{TR} and thickness mode solution – SL_T

2. SYNTHESIS OF NETWORK EQUIVALENT CIRCUIT

The equivalent network model of piezoceramic transducer including radial and thickness modes of vibrations was considered in [5] and [6]. The model presented in the paper is based on the synthesis of impedance matrix Z using the analogy between acoustical, mechanical and electrical quantities. The synthesized Z matrix can be spitted into parts that constitute three subnetworks named radial, thickness, and electric from diagonal component in the row of the matrix (the back and front equations could be combined into one subnetwork):

$$Z = \begin{bmatrix} Z_R & | & Z_{12} & | & Z_{13} \\ \text{-----} & & & & \\ Z_{12} & | & Z_T & | & Z_{23} \\ \text{-----} & & & & \\ Z_{13} & | & Z_{23} & | & Z_E \end{bmatrix} \quad (3)$$

The trans-impedances Z_{12} , Z_{13} and Z_{23} describe coupling between subnetworks that could be modeled by three 2x2 impedance matrices that describe 2-port networks:

$$Z_I = \begin{bmatrix} Z_R & Z_{12} \\ Z_{12} & Z_T \end{bmatrix} \quad Z_{II} = \begin{bmatrix} Z_T & Z_{23} \\ Z_{23} & Z_E \end{bmatrix} \quad Z_{III} = \begin{bmatrix} Z_R & Z_{13} \\ Z_{13} & Z_E \end{bmatrix} \quad (4)$$

Each subnetwork impedance matrix could be further decomposed into two matrices. As an example of the process, consider the part responsible for thickness mode of vibrations:

$$Z_{II} = \begin{bmatrix} Z_T & 0 \\ 0 & Z_E \end{bmatrix} + \begin{bmatrix} 0 & Z_{23} \\ Z_{23} & 0 \end{bmatrix} \quad (5)$$

The first matrix represents simple 2-port network with Z_T as an observed impedance of its first port and Z_E as an impedance observed from the second port. Both ports are not connected in this case due to diagonal form of the matrix. The second matrix with zeros on diagonal represents negative impedance inverter (NIV) which is rarely used in practice and considered as a theoretical element in classical theory of electric networks. Although it's theoretical, it could be quite easily implemented in SPICE simulation software in the form of two current controlled voltage sources with gain factor equal to transimpedance. The addition of impedance matrices is an equivalent of so called series-series type of connection between networks, in which input ports of both network are connected in series and output ports in series as well.

3. IMPLEMENTATION IN CIRCUIT SIMULATION SOFTWARE

The network equivalent circuit was implemented in MicroCap SPICE circuit simulator based on the principles presented in previous section. MicroCap is an integrated schematic editor and mixed analog/digital simulator that provides an interactive sketch and simulate environment for electronics engineers. Its extended features like analog behavioral sources and functions containing Laplace S-domain expressions allow implementing not typical circuit elements. Fig. 2 presents implementation of piezoceramic transducer using Laplace function current controlled voltage sources as a implementation of NIV element. The values of all elements are calculated based on PZT-5 ceramics. Its values are defined in coefficients column below the circuit. Radial impedance Z_R was also implemented using current controlled voltage source and taking advantage of internally defined Bessel functions J_0 and J_1 . The thickness impedance Z_T was implemented as a transmission line with length equal to the thickness of circular disc with frequency dependant resistance simulating mechanical losses. The dielectric losses were also added on electrical input in parallel. The load of back and side part of disc is implemented as a resistance proportional to the area of these parts. The load of active front side Z_F was again simulated by current controlled voltage source as its value equals to mechanical radiation impedance for circular piston containing Bessel J_1 and Struve H_1 functions. The latter one was approximated according to [7].

It is worth to note that all coupling trans-impedances are reactances, so they maybe interpreted as negatively inverted capacitors with values equal to:

$$C_{12} = \frac{1}{2\pi a c_{13}^D}, \quad C_{13} = \frac{a}{2lh_{31}}, \quad C_{23} = \frac{1}{h_{33}} \quad (6)$$

Hence, alternatively, NIV could be implemented using balanced X-lattice 2-port network structure with two positive and two negative capacitors.

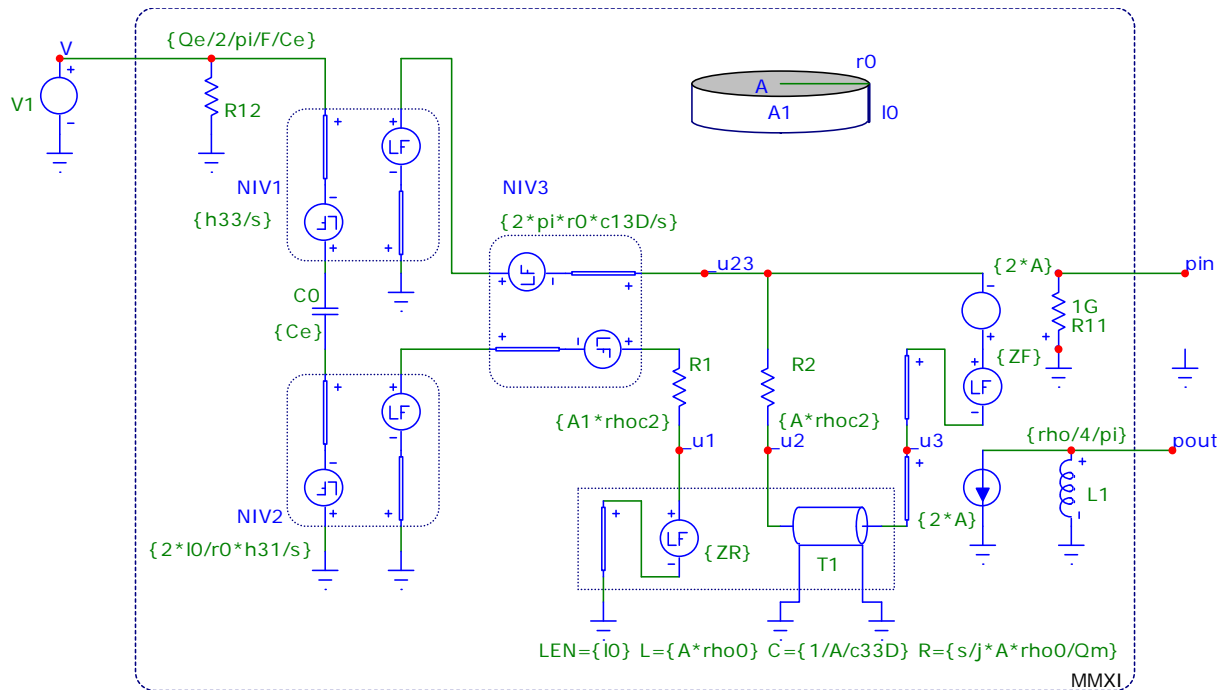

Coefficients:

```
.define K33S 830
.define rho0 7750
.define Qm 75
.define Qe 50
.define c11D 126G
.define c12D 80.9G
.define c13D 65.2G
.define c33D 147G
.define h31 -0.73G
.define h33 2.15G
```

Geometry:

```
.define r0 12.5m
.define I0 10m
.define A pi*r0^2
.define A1 2*pi*r0*I0
```

Loading:

```
.define rho 1000
.define rhoc 1.5e6
.define rhoc2 0.12e6
```

Consts and Functions:

```
.define eps0 1e-9/36/pi
.func H1(z) 2/pi-J0(z)+(16/pi-5)*sin(z)/z+(12-36/pi)*(1-cos(z))/z^2
```

Defines:

```
.define Z1 2*pi*I0*r0*sqrt(c11D*rho0)
.define kr 2*pi*f*r0/sqrt(c11D/rho0)
.define ZR Z1/j*J0(kr)/J1(kr)+2*pi*I0*(c12D-c11D)/s
.define ZF A*rhoc*(1-J1(2*kr)/kr-j*H1(2*kr)/kr)
.define Ce {K33S*eps0*A/I0}
```

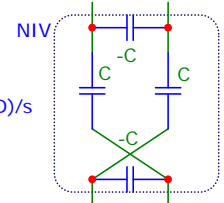

Fig. 2. Transducer's equivalent circuit taking into account thickness and radial modes of vibration as implemented using current controlled voltage sources. Alternative implementation of each NIV element by lattice 2-port network presented in lower right

The acoustic part is bifid into output interface and input one. It is assumed that transducer is mounted in infinite baffle so the mechano-acoustic transformer has a factor equal to double of transducer surface area. The output pressure p is calculated on axis in the standard distance $r_1 = 1$ m as usually used when defining such parameters like Transmitting Voltage Response (TVR) of transducer or Source Level (SL) of echo-sounder. When implementing Rayleigh integral in a circuit simulator, it is convenient to implement the phenomenon (the transmitted pressure proportional to wave frequency) in the form of inductor driven by current controlled current source. When simulating receiver of echo-sounder the input interface should be used which transforms pressure at the transducer face (voltage) into driving force (voltage) using voltage controlled voltage source. Fig. 3. shows Source Level of an echo-sounder and its Receiving Sensitivity as obtained from network simulation.

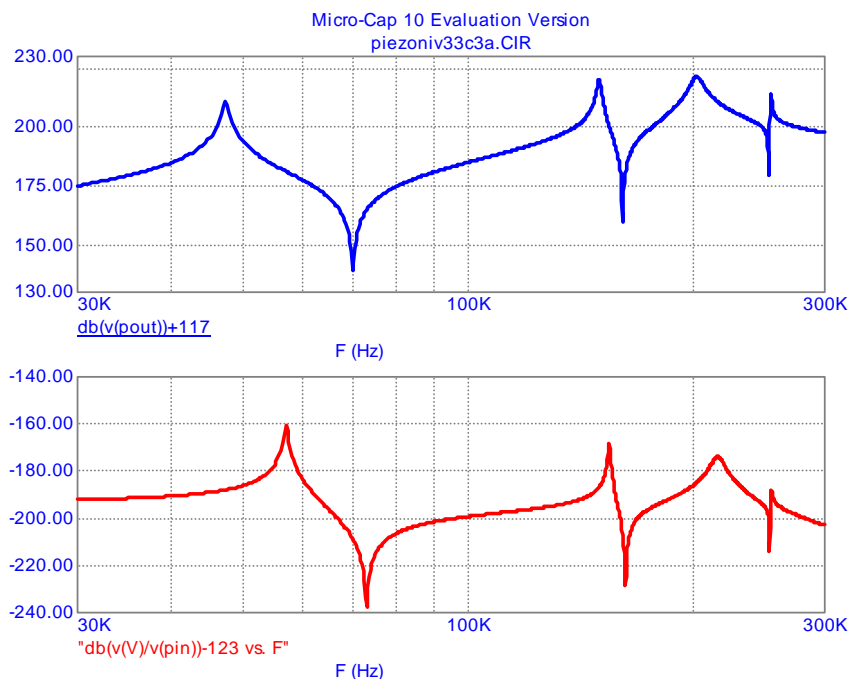

Fig. 3. Simulated results showing Source Level and Receiver Sensitivity of a hypothetical echo-sounder

4. CONCLUSIONS

The network equivalent circuit of piezoceramic circular disk was modeled taking into account radial and thickness mode of vibration. It was implemented in circuit simulation software as a part of dual-frequency echo-sounder, for which the parameter like source level and receiver sensitivity could be calculated for both designed frequencies.

REFERENCES

- [1] Brissaud M., Three-Dimensional Modeling of Piezoelectric Materials, *IEEE Transaction on Ultrasonics, Ferroelectrics and Frequency Control*, Vol. 57, No 5, (2010), 2051–2065.
- [2] Paul H. S., Vibrations of Circular Cylindrical Shells of Piezoelectric Silver Iodide Crystals, *J. Acoust. Soc. Am.* 40, (1966), 1077–1080.
- [3] Ebenezer D. D., Ramesh R., Analysis of axially polarized piezoelectric cylinders with arbitrary boundary conditions on flat surfaces, *J. Acoust. Soc. Am.* 113(4), (2003), 1900–1908.
- [4] Iula A., Lamberti N., Pappalardo M., An Approximated 3-D Model of Cylinder-Shaped Piezoceramic Elements for Transducer Design, *IEEE Transaction on Ultrasonics, Ferroelectrics and Frequency Control*, Vol. 45, No 4, (1998), 1056–1064.
- [5] Lin S., Study on the equivalent circuit and coupled vibration for the longitudinally polarized piezoelectric ceramic hollow cylinders, *Journal of Sound and Vibration*, Vol. 275, (2004), 859–875.
- [6] Feng F., Shen J., Deng J., A 2D equivalent circuit of piezoelectric ceramic ring for transducer design, *Ultrasonics*, Vol. 44, (2006), e723–e726.
- [7] Aarts R. M., Janssen A. J. E. M., Approximation of the Struve function H_1 occurring in impedance calculations, *J. Acoust. Soc. Am.* 113(5), (2003), 2635–2637.