

On unique kinematics for the branching shells

W. Pietraszkiewicz^{a,*}, V. Konopińska^b

^a Institute of Fluid Flow Machinery, PAFci, ul. Gen. J. Fiszera 14, 80-952 Gdańsk, Poland

^b Gdańsk University of Technology, Department of Structural Mechanics and Bridge Structures, ul. G. Narutowicza 11/12, 80-952 Gdańsk, Poland

ARTICLE INFO

Article history:

Received 2 August 2010

Received in revised form 29 March 2011

Available online 3 April 2011

Keywords:

Shell

Junction

Branching

Finite rotation

Principle of virtual work

ABSTRACT

We construct the unique two-dimensional (2D) kinematics which is work-conjugate to the exact, resultant local equilibrium conditions of the non-linear theory of branching shells. It is shown that the compatible shell displacements consist of the translation vector and rotation tensor fields defined on the regular parts of the shell base surface as well as independently on the singular surface curve modelling the shell branching. Discussing relations between limits of the translation vector and rotation tensor fields when approaching the singular curve, and analogous fields given only along the singular curve itself, several types of the junctions are described. Among them are the stiff, entirely simply connected and partly simply supported junction as well as the elastically and dissipatively deformable junction, and the non-local elastic junction. For each type of junction the explicit form of the principle of virtual work is derived.

© 2011 Elsevier Ltd. All rights reserved.

1. Introduction

Already Reissner (1974, 1982) noticed that the 2D kinematic structure of the general theory of regular shells, which is uniquely induced by the exact, resultant local shell equilibrium equations, corresponds to that proposed by Cosserat and Cosserat (1909). Libai and Simmonds (1983, 1998) formulated the 2D kinematics for shells modelled by a non-material weighted surface of mass taken as the shell base surface during deformation process. When the base surface is taken to be a material surface arbitrary located in the shell-like body, the 2D shell kinematics was discussed by Makowski and Stumpf (1990) and Chróścielewski et al. (1992) and summarised in detail in the book by Chróścielewski et al. (2004), where references to other papers are given. In the above works the 2D shell kinematics was uniquely established as the work-conjugate dual structure following from some 2D integral identity of the virtual work type. As a result, the unique 2D shell displacements are described by six fields: three components of the translation vector \mathbf{u} and three independent parameters of the rotation tensor \mathbf{Q} fields describing the gross deformation of the shell cross section.

In case of irregular shell structures, called also multi-shells, several special cases of 2D six-field shell kinematics were discussed by Makowski and Stumpf (1994), Chróścielewski et al. (1997, 2004) and Pietraszkiewicz (2001). In those works it was assumed that the region of irregularity (branching, self-intersection, stiffening,

technological junction, etc.) is small as compared with other dimensions of the shell base surface and its size can be disregarded. Such an assumption introduced an undefinable error into the resultant dynamic continuity conditions at the singular surface curves and points modelling the regions of irregularity. Konopińska and Pietraszkiewicz (2007) removed this inaccuracy and formulated the exact, resultant 2D equilibrium conditions for the general, non-linear six-field theory of branching and self-intersecting shells.

In this note by extending the results of Konopińska (2007) we construct the dual structure work-conjugate to the exact resultant equilibrium conditions derived by Konopińska and Pietraszkiewicz (2007). This structure represents the unique 2D kinematics on the irregular shell base surface M for the branching shell. We begin with the integral identity (9) in which initially arbitrary vector fields \mathbf{v} and \mathbf{w} are interpreted as the kinematically admissible virtual translations $\delta\mathbf{u}$ and rotations ω corresponding to the real deformation of the shell base surface. This allows us to introduce the 2D principle of virtual work (21) formulated on the irregular material base surface M which includes the stationary singular curve Γ modelling the region of shell branching. As a result, the shell displacements consist of two fields \mathbf{u} , \mathbf{Q} on $M \setminus \Gamma$ and independent two fields \mathbf{u}_Γ , \mathbf{Q}_Γ defined only along Γ . Then we discuss relations between limits of the fields \mathbf{u} , \mathbf{Q} when approaching Γ and the fields \mathbf{u}_Γ , \mathbf{Q}_Γ themselves. In this way several types of junctions at Γ can be described. Among them are the stiff, entirely simply connected, partly simply supported and partly deformable junctions. For each type of junction we characterize its specific kinematics and establish the appropriate form of the principle of virtual work.

* Corresponding author. Tel.: +48 58 69 95 263; fax: +48 58 341 61 44.

E-mail address: pietrasz@karol.imp.gda.pl (W. Pietraszkiewicz).

2. Notation and local equilibrium conditions

A shell is a 3D thin solid body identified in a reference (undeformed) placement with a region B of the physical space \mathcal{E} having E as its 3D translation vector space. The position vector $\mathbf{x} = \mathbf{x} - \mathbf{o}$ of any point $x \in B$ relative to an origin $\mathbf{o} \in \mathcal{E}$ can be given by

$$\mathbf{x}(x, \xi) = \mathbf{x}(x) + \xi \mathbf{t}(x), \tag{1}$$

where $\mathbf{x}(x) = \mathbf{x}(x, 0)$ is the position vector of a point x of some undeformed base surface M , while ξ is the distance from M to x along the unit vector \mathbf{t} not necessarily normal to M .

The position vector $\mathbf{y} = \chi(x) = \mathbf{y} - \mathbf{o}$ relative to the same origin $\mathbf{o} \in \mathcal{E}$ of any shell point y in the deformed placement $\bar{B} = \chi(B)$ can always be represented by

$$\mathbf{y}(x, \xi) = \mathbf{y}(x) + \mathbf{z}(x, \xi), \quad \mathbf{z}(x, 0) = \mathbf{0}, \tag{2}$$

where $\mathbf{y} = \chi(x)$ is the position vector of the deformed material base surface $\bar{M} = \chi(M)$, and \mathbf{z} is a deviation of $y \in B$ from $\bar{M} = \chi(M)$.

For the branching and self-intersecting shells Konopińska and Pietraszkiewicz (2007) worked out the through-the-thickness integration procedure leading to the exact, resultant local equilibrium conditions for any part $\Pi \in M$ which includes the singular surface curve Γ modelling the common junction of regular branches M_k , $k = 1, \dots, n$, of M , with $n = 3$ for the branching and $n = 4$ for the self-intersection.

In the referential description these resultant local equilibrium conditions consist of the equilibrium equations in $\Pi \subset M \setminus \Gamma$,

$$\text{Div}_s \mathbf{N} + \mathbf{f} \equiv \tilde{\mathbf{f}} = \mathbf{0}, \quad \text{Div}_s \mathbf{M} + ax(\mathbf{N}\mathbf{F}^T - \mathbf{F}\mathbf{N}^T) + \mathbf{c} \equiv \tilde{\mathbf{c}} = \mathbf{0}; \tag{3}$$

the static boundary conditions along that part $\partial \Pi_f \subset \partial M_f$ where the resultant forces and couples are prescribed,

$$\mathbf{n}^* - \mathbf{N}\mathbf{v} \equiv \tilde{\mathbf{n}} = \mathbf{0}, \quad \mathbf{m}^* - \mathbf{M}\mathbf{v} \equiv \tilde{\mathbf{m}} = \mathbf{0}; \tag{4}$$

the static continuity conditions along $\Gamma \cap \Pi$,

$$\llbracket \mathbf{N}\mathbf{v} \rrbracket + \mathbf{f}_\Gamma \equiv \tilde{\mathbf{f}}_\Gamma = \mathbf{0}, \quad \llbracket \mathbf{M}\mathbf{v} \rrbracket + \mathbf{c}_\Gamma \equiv \tilde{\mathbf{c}}_\Gamma = \mathbf{0}; \tag{5}$$

and the static boundary conditions

$$\mathbf{n}_e - \mathbf{n}_i \equiv \tilde{\mathbf{n}}_x = \mathbf{0}, \tag{6}$$

$$\mathbf{m}_e - \mathbf{m}_i + \mathbf{y}_e \times \mathbf{n}_e - \mathbf{y}_i \times \mathbf{n}_i \equiv \tilde{\mathbf{m}}_x = \mathbf{0}$$

at the singular points $x_i, x_e \in \Gamma \cap \partial M_f$, see Fig. 1.

In (3)–(5), $(\mathbf{N}, \mathbf{M}) \in E \otimes T_x M$ are the surface stress resultant and stress couple tensors of the 1st Piola–Kirchhoff type, which are related to the corresponding stress resultant and stress couple vectors $\mathbf{n}_v, \mathbf{m}_v$, defined along any edge $\partial \Pi$ of a regular part $\Pi \subset M$ by the surface Cauchy theorem $\mathbf{n}_v = \mathbf{N}\mathbf{v}$, $\mathbf{m}_v = \mathbf{M}\mathbf{v}$, where $\mathbf{v} \in T_x M$ is the unit vector externally normal to $\partial \Pi$. In (3)–(6), $(\mathbf{f}, \mathbf{c}) \in E$ are the surface resultant force and couple vectors, Grad_s and Div_s denote the referential surface gradient and divergence operators on M , $(\mathbf{n}^*, \mathbf{m}^*) \in E$ are the boundary resultant force and couple vectors along ∂M_f ,

$(\mathbf{f}_\Gamma, \mathbf{c}_\Gamma) \in E$ are the compensating curvilinear resultant force and couple vectors along Γ , while $\mathbf{n}_i, \mathbf{m}_i$ and $\mathbf{n}_e, \mathbf{m}_e$ are the compensating concentrated force and couple vectors applied at the initial x_i and end x_e points of Γ , respectively. Additionally, $ax(\mathbf{A})$ means the axial vector of the skew tensor $\mathbf{A}^T = -\mathbf{A}$, $\llbracket \mathbf{a} \rrbracket$ is the jump of the vector field $\mathbf{a}(x)$ at the singular surface curve Γ , and $(\cdot)' \equiv \frac{d}{ds}(\cdot)$.

In Konopińska and Pietraszkiewicz (2007) the compensating concentrated forces $\mathbf{n}_e, \mathbf{n}_i$ and couples $\mathbf{m}_e, \mathbf{m}_i$ were equivalently represented by curvilinear integrals over some distributed loads \mathbf{n}, \mathbf{m} along Γ . In the present paper we do not use this equivalent representation.

The relations (3) and (4) are formally equivalent to those given for the regular shell for example by Libai and Simmonds (1983) and Makowski and Stumpf (1990). The static relations (5) and (6) complete by some correcting terms various analogous approximate relations proposed by Makowski and Stumpf (1994), Chróścielewski et al. (1997, 2004) and Pietraszkiewicz (2001) using alternative approximate reduction procedures.

To avoid ambiguity, let us recall that in this paper the surface gradient Grad_s of a differentiable vector field $\mathbf{v}(x) \in E$ is the 2nd-order tensor field $\text{Grad}_s \mathbf{v}(x) \in E \otimes T_x M$ defined by

$$\{\text{Grad}_s \mathbf{v}(x)\} \mathbf{a} = \frac{d}{dt} \mathbf{v}(x + t\mathbf{a})|_{t=0} \quad \text{for any } t \in \mathbb{R}, \mathbf{a} \in T_x M. \tag{7}$$

The surface divergence Div_s of a differentiable tensor field $\mathbf{A}(x) \in E \otimes T_x M$ is the vector field $\text{Div}_s \mathbf{A}(x) \in E$ satisfying

$$\{\text{Div}_s \mathbf{A}(x)\} \cdot \mathbf{b} = \text{Div}_s \{\mathbf{A}^T(x)\mathbf{b}\} = \text{tr}\{\text{Grad}_s(\mathbf{A}^T(x)\mathbf{b})\} \quad \text{for any } \mathbf{b} \in E. \tag{8}$$

3. Work-conjugate shell kinematics

Let $(\mathbf{v}, \mathbf{w}) \in E$ be two vector fields smooth in regular points of $M \setminus \Gamma$, and $(\mathbf{v}_\Gamma, \mathbf{w}_\Gamma) \in E$ be two other vector fields smooth along Γ including the initial x_i and end x_e points of $\Pi \cap \Gamma$. Then for any part $\Pi \subset M$ containing a part of Γ , Fig. 1, we can set the integral identity

$$\int \int_{\Pi \setminus \Gamma} (\tilde{\mathbf{f}} \cdot \mathbf{v} + \tilde{\mathbf{c}} \cdot \mathbf{w}) da + \int \int_{\Pi \cap \partial M_f} (\tilde{\mathbf{n}} \cdot \mathbf{v} + \tilde{\mathbf{m}} \cdot \mathbf{w}) ds - \int \int_{\Pi \cap \Gamma} (\tilde{\mathbf{f}}_\Gamma \cdot \mathbf{v}_\Gamma + \tilde{\mathbf{c}}_\Gamma \cdot \mathbf{w}_\Gamma) ds - \tilde{\mathbf{n}}_x \cdot \mathbf{v}_\Gamma - \tilde{\mathbf{m}}_x \cdot \mathbf{w}_\Gamma = 0. \tag{9}$$

Introducing (3)–(6) into (9) we can transform the identity as suggested in Chróścielewski et al. (2004, Chapter 3).

In particular, note that by simple algebra

$$(\text{Div}_s \mathbf{N}) \cdot \mathbf{v} = \mathbf{N} \bullet \text{Grad}_s \mathbf{v}, \quad (\text{Div}_s \mathbf{M}) \cdot \mathbf{w} = \mathbf{M} \bullet \text{Grad}_s \mathbf{w}, \tag{10}$$

$$ax(\mathbf{N}\mathbf{F}^T - \mathbf{F}\mathbf{N}^T) \cdot \mathbf{w} = -\frac{1}{2}(\mathbf{N}\mathbf{F}^T - \mathbf{F}\mathbf{N}^T) \bullet \mathbf{W} = \mathbf{N} \bullet (\mathbf{W}\mathbf{F}),$$

where \bullet is the scalar product in the tensor space such that for any $\mathbf{A}, \mathbf{B} \in E \otimes T_x M$, $\mathbf{A} \bullet \mathbf{B} = \text{tr}(\mathbf{A}^T \mathbf{B})$, $\mathbf{W} = \mathbf{w} \times \mathbf{1}$ is the skew tensor, and $\mathbf{1}$ means the unit tensor of $E \otimes E$.

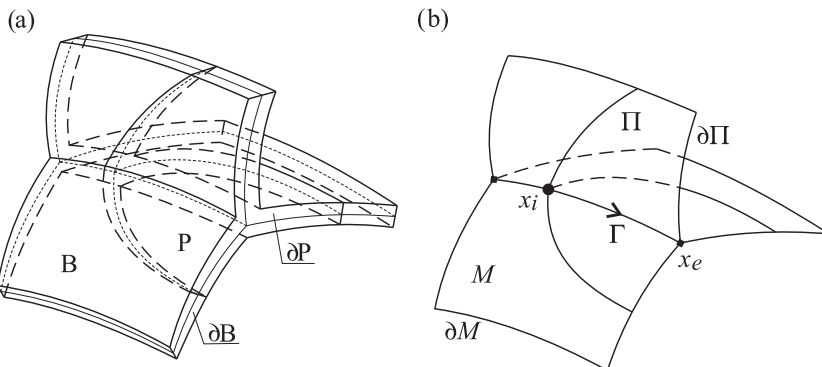

Fig. 1. The branching shell element: (a) the 3D shell, (b) the corresponding 2D base surface.

Let us apply in the reverse order the divergence theorem used by Konopińska and Pietraszkiewicz (2007, f. (23)–(26)). Then the first integral of (9) with (10) can be transformed as follows:

$$\begin{aligned} \iint_{M \setminus \Gamma} (\tilde{\mathbf{f}} \cdot \mathbf{v} + \tilde{\mathbf{c}} \cdot \mathbf{w}) da &= \iint_{M \setminus \Gamma} \{(\text{Div}_s \mathbf{N} + \mathbf{f}) \cdot \mathbf{v} \\ &+ [\text{Div}_s \mathbf{M} + \alpha \chi (\mathbf{N} \mathbf{F}^T - \mathbf{F} \mathbf{N}^T) + \mathbf{c}] \cdot \mathbf{w}\} da \\ &= - \iint_{M \setminus \Gamma} \{\mathbf{N} \bullet \text{Grad}_s \mathbf{v} - \mathbf{N} \bullet (\mathbf{W} \mathbf{F}) \\ &+ \mathbf{M} \bullet \text{Grad}_s \mathbf{w}\} da + \int_{\Pi \cap \Gamma} (\llbracket \mathbf{N} \mathbf{v} \cdot \mathbf{v} \rrbracket \\ &+ \llbracket \mathbf{M} \mathbf{v} \cdot \mathbf{w} \rrbracket) ds + \int_{\Pi \setminus \Gamma} (\mathbf{f} \cdot \mathbf{v} + \mathbf{c} \cdot \mathbf{w}) da \\ &+ \int_{\Pi \cap \partial M_f} (\mathbf{N} \mathbf{v} \cdot \mathbf{v} + \mathbf{M} \mathbf{v} \cdot \mathbf{w}) ds \\ &+ \int_{\Pi \cap \partial M_d} (\mathbf{N} \mathbf{v} \cdot \mathbf{v} + \mathbf{M} \mathbf{v} \cdot \mathbf{w}) ds. \end{aligned} \quad (11)$$

In (11), $\partial M_d = \partial M \setminus \partial M_f$ is the complementary part of ∂M where the kinematic boundary conditions $\mathbf{u} = \mathbf{u}^*$, $\mathbf{Q} = \mathbf{Q}^*$ are prescribed, and the jumps along the singular curve Γ are defined by

$$\llbracket \mathbf{N} \mathbf{v} \cdot \mathbf{v} \rrbracket = \sum_{k=1}^3 \mathbf{N}_k \mathbf{v}_k \cdot \mathbf{v}_k, \quad \llbracket \mathbf{M} \mathbf{v} \cdot \mathbf{w} \rrbracket = \sum_{k=1}^3 \mathbf{M}_k \mathbf{v}_k \cdot \mathbf{w}_k. \quad (12)$$

In (12), \mathbf{N}_k and \mathbf{M}_k are the one-sided finite limits of \mathbf{N} and \mathbf{M} when the respective boundary ∂M_k coinciding with Γ is approached, respectively, and $\mathbf{v}_k \in T_x M_k$ is the unit vector externally normal to ∂M_k .

The second integral of (9) can be divided into two parts

$$\begin{aligned} \int_{\Pi \cap \partial M_f} (\tilde{\mathbf{n}} \cdot \mathbf{v} + \tilde{\mathbf{m}} \cdot \mathbf{w}) ds &= \int_{\partial \Pi \cap \partial M_f} (\mathbf{n}^* \cdot \mathbf{v} + \mathbf{m}^* \cdot \mathbf{w}) ds \\ &- \int_{\partial \Pi \cap \partial M_f} (\mathbf{N} \mathbf{v} \cdot \mathbf{v} + \mathbf{M} \mathbf{v} \cdot \mathbf{w}) ds. \end{aligned} \quad (13)$$

The third integral of (9) can also be rewritten in two parts

$$\begin{aligned} - \int_{\Pi \cap \Gamma} (\tilde{\mathbf{f}}_r \cdot \mathbf{v}_r + \tilde{\mathbf{c}}_r \cdot \mathbf{w}_r) ds &= - \int_{\Pi \cap \Gamma} (\llbracket \mathbf{N} \mathbf{v} \rrbracket \cdot \mathbf{v}_r + \llbracket \mathbf{M} \mathbf{v} \rrbracket \cdot \mathbf{w}_r) ds \\ &- \int_{\Pi \cap \Gamma} (\mathbf{f}_r \cdot \mathbf{v}_r + \mathbf{c}_r \cdot \mathbf{w}_r) ds, \end{aligned} \quad (14)$$

where all fields are defined only along Γ .

Since Π is an arbitrarily chosen part of M , the results presented in (11)–(14) are valid for the whole M as well, so that (9) with (11), (13) and (14) for the whole M with Γ leads to

$$\begin{aligned} &- \iint_{M \setminus \Gamma} \{\mathbf{N} \bullet (\text{Grad}_s \mathbf{v} - \mathbf{W} \mathbf{F}) + \mathbf{M} \bullet \text{Grad}_s \mathbf{w}\} da \\ &+ \iint_{M \setminus \Gamma} (\mathbf{f} \cdot \mathbf{v} + \mathbf{c} \cdot \mathbf{w}) da + \int_{\partial M_f} (\mathbf{n}^* \cdot \mathbf{v} + \mathbf{m}^* \cdot \mathbf{w}) ds \\ &- \int_{\Gamma} (\mathbf{f}_r \cdot \mathbf{v}_r + \mathbf{c}_r \cdot \mathbf{w}_r) ds + \int_{\partial M_d} (\mathbf{N} \mathbf{v} \cdot \mathbf{v} + \mathbf{M} \mathbf{v} \cdot \mathbf{w}) ds \\ &+ \int_{\Gamma} \{\llbracket \mathbf{N} \mathbf{v} \rrbracket \cdot \mathbf{v} - \llbracket \mathbf{N} \mathbf{v} \rrbracket \cdot \mathbf{v}_r + \llbracket \mathbf{M} \mathbf{v} \rrbracket \cdot \mathbf{w} \\ &- \llbracket \mathbf{M} \mathbf{v} \rrbracket \cdot \mathbf{w}_r\} ds - (\mathbf{n}_e \cdot \mathbf{v}_{r_e} - \mathbf{n}_i \cdot \mathbf{v}_{r_i}) \\ &- \{(\mathbf{m}_e + \mathbf{y}_e \times \mathbf{n}_e) \cdot \mathbf{w}_{r_e} - (\mathbf{m}_i + \mathbf{y}_i \times \mathbf{n}_i) \cdot \mathbf{w}_{r_i}\} = 0. \end{aligned} \quad (15)$$

Let the real shell deformation be described by the translation vectors $\mathbf{u} = \mathbf{y} - \mathbf{x} \in E$ and $\mathbf{u}_r = \mathbf{y}_r - \mathbf{x}_r \in E$ of the base surface as well as the rotation tensors \mathbf{Q} and $\mathbf{Q}_r \in SO(3)$ of the shell cross sections defined as $\mathbf{Q} = \mathbf{d}_i \otimes \mathbf{t}_i$, $\mathbf{Q}_r = \mathbf{d}_i^r \otimes \mathbf{t}_i^r$, where \mathbf{d}_i , \mathbf{d}_i^r and $\mathbf{t}_i = (\mathbf{t}_{\alpha}, \mathbf{t}_3)$, $\mathbf{t}_i^r = (\mathbf{t}_{\alpha}^r, \mathbf{t}_3^r)$, $i = 1, 2, 3$, $\alpha = 1, 2$, are triads of orthonormal directors in the deformed and undeformed placement associated with $M \setminus \Gamma$ and Γ , respectively. Then the vector fields \mathbf{v} , \mathbf{v}_r and \mathbf{w} , \mathbf{w}_r may be interpreted, in particular, as the kinematically admissible virtual translations and rotations

$$\mathbf{v} = \delta \mathbf{u}, \quad \mathbf{v}_r = \delta \mathbf{u}_r, \quad \mathbf{w} = (\delta \mathbf{Q}) \mathbf{Q}^T \equiv \boldsymbol{\omega}, \quad \mathbf{w}_r = (\delta \mathbf{Q}_r) \mathbf{Q}_r^T \equiv \boldsymbol{\omega}_r, \quad (16)$$

such that $\delta \mathbf{u} = \boldsymbol{\omega} = \mathbf{0}$ along ∂M_d , and δ is the symbol of virtual change (variation). With such virtual displacements the integral over ∂M_d in the third row of (15) vanishes. In the last two rows of (15) the terms at points $(x_i, x_e) \in \partial M_d$ identically vanish as well, because the compensating concentrated forces and couples are defined only at $(x_i, x_e) \in \partial M_f$.

Moreover, two integrals in the second row, the first integral in the third row and terms in the last two rows of (15) may now be interpreted as the external virtual work performed by the given surface \mathbf{f} , \mathbf{c} , boundary \mathbf{n}^* , \mathbf{m}^* and compensating concentrated \mathbf{n}_i , \mathbf{n}_e , \mathbf{m}_i , \mathbf{m}_e loads as well as by the compensating loads \mathbf{f}_r , \mathbf{c}_r prescribed along Γ , respectively. In this context the first surface integral in (15) should have the meaning of internal virtual work performed by \mathbf{N} , \mathbf{M} on the respective virtual strain measures $\text{Grad}_s \delta \mathbf{u} - \boldsymbol{\Omega} \mathbf{F}$, $\text{Grad}_s \boldsymbol{\omega}$, where $\boldsymbol{\Omega} = \boldsymbol{\omega} \times \mathbf{1}$. These virtual strain measures should now be expressed by variations of appropriately defined global 2D stretch and bending measures on $M \setminus \Gamma$.

The 2D strain measures on $M \setminus \Gamma$ corresponding to the 2D virtual strain measures were discussed in Chrościelewski et al. (2004), Pietraszkiewicz et al. (2005) and Eremeyev and Pietraszkiewicz (2006). It was found that

$$\text{Grad}_s \delta \mathbf{u} - \boldsymbol{\Omega} \mathbf{F} = \delta^c \mathbf{E}, \quad \text{Grad}_s \boldsymbol{\omega} = \delta^c \mathbf{K}, \quad (17)$$

where $\delta^c(\cdot) = \mathbf{Q} \delta \{ \mathbf{Q}^T(\cdot) \}$ is the co-rotational variation of (\cdot) , and the 2D stretch and bending tensors are defined by

$$\mathbf{E} = \mathbf{J} \mathbf{F} - \mathbf{Q} \mathbf{I}, \quad \mathbf{K} = \mathbf{C} \mathbf{F} - \mathbf{Q} \mathbf{B}. \quad (18)$$

In (18), $\mathbf{I} = \text{Grad}_s \mathbf{x} \in E \otimes T_x M$ and $\mathbf{J} = \text{grad}_s \mathbf{y} \in E \otimes T_y \bar{M}$ are the inclusion operators on $M \setminus \Gamma$ and $\bar{M} \setminus \bar{\Gamma}$, $\mathbf{F} \in T_y \bar{M} \otimes T_x M$ is the tangential surface deformation gradient such that $d\mathbf{y} = \mathbf{F} d\mathbf{x}$, while \mathbf{B} and \mathbf{C} are the structure curvature tensors of the base surface in the undeformed $M \setminus \Gamma$ and deformed $\bar{M} \setminus \bar{\Gamma}$ placements, respectively, defined as follows:

$$\mathbf{T} = \mathbf{t}_i \otimes \mathbf{e}_i, \quad \text{ax} \{ (d\mathbf{T}) \mathbf{T}^{-1} \} = \mathbf{B} d\mathbf{x}, \quad \mathbf{B} \in E \otimes T_x M, \quad (19)$$

$$\mathbf{D} = \mathbf{Q} \mathbf{T} = \mathbf{d}_i \otimes \mathbf{e}_i, \quad \text{ax} \{ (d\mathbf{D}) \mathbf{D}^{-1} \} = \mathbf{C} d\mathbf{y}, \quad \mathbf{C} \in E \otimes T_y \bar{M},$$

where \mathbf{e}_i are the orthonormal base vectors of a 3D inertial frame of reference.

The description of shell deformation given in (16)–(19) is equivalent to that proposed by Cosserat and Cosserat (1909).

If we introduce the virtual strain energy density in $M \setminus \Gamma$ defined as

$$\sigma = \mathbf{N} \bullet \delta^c \mathbf{E} + \mathbf{M} \bullet \delta^c \mathbf{K}, \quad (20)$$

then the principle of virtual work following from (15) for the branching shell can be given in the form

$$\begin{aligned}
 \iint_{M \setminus \Gamma} \sigma da &= \iint_{M \setminus \Gamma} (\mathbf{f} \cdot \delta \mathbf{u} + \mathbf{c} \cdot \boldsymbol{\omega}) da \\
 &+ \int_{\partial M_f} (\mathbf{n}^* \cdot \delta \mathbf{u} + \mathbf{m}^* \cdot \boldsymbol{\omega}) ds \\
 &- \int_{\Gamma} (\mathbf{f}_\Gamma \cdot \delta \mathbf{u}_\Gamma + \mathbf{c}_\Gamma \cdot \boldsymbol{\omega}_\Gamma) ds \\
 &+ \int_{\Gamma} \{ [\mathbf{N}\mathbf{v} \cdot \delta \mathbf{u}] - [\mathbf{N}\mathbf{v}] \cdot \delta \mathbf{u}_\Gamma + [\mathbf{M}\mathbf{v} \cdot \boldsymbol{\omega}] \\
 &- [\mathbf{M}\mathbf{v}] \cdot \boldsymbol{\omega}_\Gamma \} ds - (\mathbf{n}_e \cdot \delta \mathbf{u}_{\Gamma e} - \mathbf{n}_i \cdot \delta \mathbf{u}_{\Gamma i}) \\
 &- \{ (\mathbf{m}_e + \mathbf{y}_e \times \mathbf{n}_e) \cdot \boldsymbol{\omega}_{\Gamma e} - (\mathbf{m}_i + \mathbf{y}_i \times \mathbf{n}_i) \cdot \boldsymbol{\omega}_{\Gamma i} \}. \quad (21)
 \end{aligned}$$

In the PVW (21), two surface integrals over $M \setminus \Gamma$ and one line integral along ∂M_f are the classical contributions appearing for the regular base surface. All other terms in (21) take into account that now M is the irregular surface containing the singular curve Γ modelling the surface branching. The minus sign in front of some terms reflects the virtual works of compensating loads which had to be subtracted in Konopińska and Pietraszkiewicz (2007) to assure the exact global force and couple equilibrium of the branching shell.

The line integral along Γ in the fourth and fifth rows of (21) contains the jump terms which explicit forms depend on the type of junction modelled by Γ . This integral describing the shell-junction interaction (S-JI) for some types of shell junction will be discussed in detail below.

4. Junctions at shell branching

Let us discuss in more detail the branching shell whose undeformed base surface M consists of three regular parts M_k , $k = 1, 2, 3$, joined together along the common junction modelled by the singular curve Γ , see Fig. 1.

In general, one can independently characterise the behaviour of all six components of \mathbf{u} and \mathbf{Q} when Γ is approached along a path within each M_k . This would lead to a large variety of junctions characterised by any of 36 combinations of such relations for each M_k .

In this paper we assume that the translations of the base surface always remain continuous during deformation, i.e. the kinematic continuity conditions $\mathbf{u}_k = \mathbf{u}_\Gamma$ are always satisfied, where \mathbf{u}_k mean the one-sided limits of \mathbf{u} on each M_k when Γ is approached.

Since

$$[\mathbf{N}\mathbf{v} \cdot \delta \mathbf{u}] = [\mathbf{N}\mathbf{v}] \cdot \langle \delta \mathbf{u} \rangle + \langle \mathbf{N}\mathbf{v} \rangle \cdot [\delta \mathbf{u}], \quad (22)$$

where $\langle \mathbf{a} \rangle$ means the average value of \mathbf{a} at Γ , by translational continuity conditions we have $\langle \delta \mathbf{u} \rangle = \delta \mathbf{u}_\Gamma$ and $[\delta \mathbf{u}] = \mathbf{0}$, so that in this case

$$[\mathbf{N}\mathbf{v} \cdot \delta \mathbf{u}] = [\mathbf{N}\mathbf{v}] \cdot \delta \mathbf{u}_\Gamma. \quad (23)$$

With (23), the first two terms in the S-JI integral of the fourth and fifth rows of (21) cancel each other out. As a result, different types of junctions along Γ can now be characterised by additional constraints put on one-sided limits \mathbf{Q}_k of \mathbf{Q} when Γ is approached.

4.1. Stiff junction

The junction is called *stiff* along Γ if both \mathbf{u} and \mathbf{Q} are continuous on the whole M including Γ , see Fig. 2, that is

$$\mathbf{u}_k = \mathbf{u}_\Gamma, \quad \mathbf{Q}_k = \mathbf{Q}_\Gamma, \quad k = 1, 2, 3. \quad (24)$$

In this case in the integrand of the S-JI integral we have not only (23) but also

$$[\mathbf{M}\mathbf{v} \cdot \boldsymbol{\omega}] = [\mathbf{M}\mathbf{v}] \cdot \boldsymbol{\omega}_\Gamma, \quad (25)$$

so that the S-JI integral identically vanishes. As a result, the kinematics of the branching shell with all junctions stiff along Γ is

entirely described by two fields \mathbf{u} , \mathbf{Q} smooth in the whole M containing Γ . The corresponding PVW reads

$$\begin{aligned}
 \iint_{M \setminus \Gamma} \sigma da &= \iint_{M \setminus \Gamma} (\mathbf{f} \cdot \delta \mathbf{u} + \mathbf{c} \cdot \boldsymbol{\omega}) da \\
 &+ \int_{\partial M_f} (\mathbf{n}^* \cdot \delta \mathbf{u} + \mathbf{m}^* \cdot \boldsymbol{\omega}) ds \\
 &- \int_{\Gamma} (\mathbf{f}_\Gamma \cdot \delta \mathbf{u}_\Gamma + \mathbf{c}_\Gamma \cdot \boldsymbol{\omega}_\Gamma) ds \\
 &- (\mathbf{n}_e \cdot \delta \mathbf{u}_e - \mathbf{n}_i \cdot \delta \mathbf{u}_i) \\
 &- \{ (\mathbf{m}_e + \mathbf{y}_e \times \mathbf{n}_e) \cdot \boldsymbol{\omega}_e - (\mathbf{m}_i + \mathbf{y}_i \times \mathbf{n}_i) \cdot \boldsymbol{\omega}_i \}, \quad (26)
 \end{aligned}$$

where $\delta \mathbf{u}_e$, $\delta \mathbf{u}_i$ and $\boldsymbol{\omega}_e$, $\boldsymbol{\omega}_i$ are the virtual translation and rotation vectors of M evaluated at the points x_e , $x_i \in M$, respectively.

4.2. Entirely simply connected junction

The junction is called *entirely simply connected* along Γ if only \mathbf{u} is continuous at Γ but \mathbf{Q} is not constrained when approaching Γ along a path on each M_k , see Fig. 3.

In this case, when approaching Γ we have to satisfy the following independent static continuity conditions:

$$\mathbf{M}_k \mathbf{v}_k = \mathbf{0}, \quad k = 1, 2, 3. \quad (27)$$

Then, besides of (23), the third and fourth terms of S-JI integral identically vanish

$$[\mathbf{M}\mathbf{v} \cdot \boldsymbol{\omega}] = \mathbf{0}, \quad [\mathbf{M}\mathbf{v}] \cdot \boldsymbol{\omega}_\Gamma = \mathbf{0}. \quad (28)$$

The relations (23) and (28) mean that the S-JI integral vanishes as well and the corresponding PVW reduces to (26). In this case the relation of any \mathbf{Q}_k to the rotation field $\boldsymbol{\omega}_\Gamma$ cannot be uniquely established, because definition of $\boldsymbol{\omega}_\Gamma$ itself is not unique.

4.3. Partly simply supported junction

The shell junction can be called *partly simply supported* along Γ if \mathbf{u} is continuous at Γ , one of \mathbf{Q}_k is not constrained while the remaining two of \mathbf{Q}_k are assumed to coincide with \mathbf{Q}_Γ when Γ is

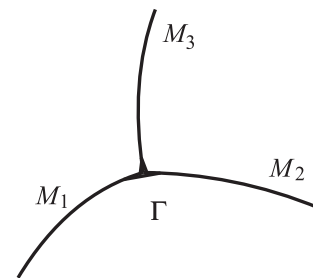

Fig. 2. Stiff junction.

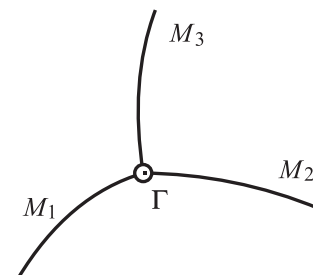

Fig. 3. Entirely simply connected junction.

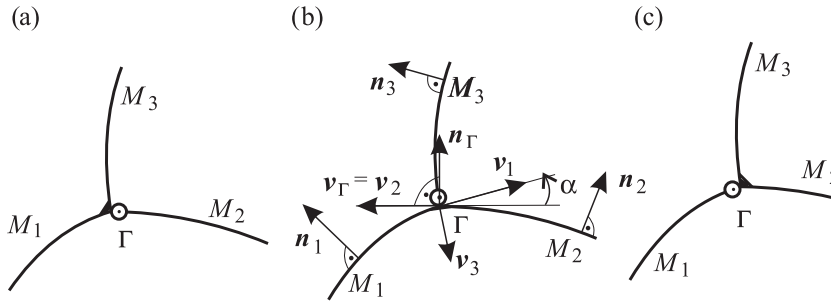

Fig. 4. Partly simply supported junctions of the branching shell.

approached. Since in our branching shell there are three branches M_k , each of them may be regarded as simply supported in the junction Γ , while the remaining two are then assumed to be stiffly connected with each other, see Fig. 4.

Let us assume, for definiteness, that the branches M_1 and M_2 are stiffly connected with each other and the branch M_3 is simply supported, see Fig. 4(b). Then the continuity conditions along Γ become

$$\begin{aligned} \mathbf{u}_k &= \mathbf{u}_\Gamma, \quad \mathbf{Q}_1 = \mathbf{Q}_2 = \mathbf{Q}_\Gamma, \quad \mathbf{M}_3 \mathbf{v}_3 = \mathbf{0}, \\ \delta \mathbf{u}_k &= \delta \mathbf{u}_\Gamma, \quad \boldsymbol{\omega}_1 = \boldsymbol{\omega}_2 = \boldsymbol{\omega}_\Gamma, \quad \boldsymbol{\omega}_3 \neq \boldsymbol{\omega}_\Gamma. \end{aligned} \quad (29)$$

Let $\mathbf{v}_\Gamma, \boldsymbol{\tau}_\Gamma, \mathbf{n}_\Gamma$ be the orthonormal triad along Γ that defines \mathbf{Q}_Γ with $\boldsymbol{\tau}_\Gamma$ tangent to Γ in the positive direction as in Fig. 1(b). Then choosing orientations of M_1 and M_2 defined by the unit normals \mathbf{n}_1 and \mathbf{n}_2 and taking $\mathbf{n}_\Gamma = \mathbf{n}_2|_\Gamma$, as is shown in Fig. 4(b), we may relate \mathbf{v}_Γ to the respective \mathbf{v}_1 and \mathbf{v}_2 according to

$$\mathbf{v}_\Gamma = \boldsymbol{\tau}_\Gamma \times \mathbf{n}_\Gamma = -\frac{1}{\cos \alpha} \mathbf{v}_1 = +\mathbf{v}_2, \quad (30)$$

where α is the angle between \mathbf{v}_1 and the tangent space $T_x M_2$ along Γ , see Fig. 4(b). In this case, within the Lagrangian description used in the PVW (21) we obtain

$$\begin{aligned} \llbracket \mathbf{M} \mathbf{v} \cdot \boldsymbol{\omega} \rrbracket &= (\mathbf{M}_1 \mathbf{v}_1) \cdot \boldsymbol{\omega}_1 + (\mathbf{M}_2 \mathbf{v}_2) \cdot \boldsymbol{\omega}_2 + (\mathbf{M}_3 \mathbf{v}_3) \cdot \boldsymbol{\omega}_3 \\ &= \{(\mathbf{M}_2 - \mathbf{M}_1 \cos \alpha) \mathbf{v}_\Gamma\} \cdot \boldsymbol{\omega}_\Gamma = \llbracket \mathbf{M} \mathbf{v} \rrbracket \cdot \boldsymbol{\omega}_\Gamma, \end{aligned} \quad (31)$$

and this term cancels out with the last term in the S-JI integral of (21). Then the curvilinear S-JI integral (21)_{4,5} vanishes as well leading to the same form (26) of the PVW as for the stiff and entirely simply connected junctions. However, now \mathbf{Q}_Γ is defined by the kinematic continuity conditions (29)₁ while \mathbf{Q}_3 can be found only in the process of solution of the boundary value problem,

in which the static continuity conditions $\mathbf{M}_3 \mathbf{v}_3 = \mathbf{0}$ is taken into account.

5. Deformable junctions

Let us discuss again the junction of the branching shell for which the translational continuity conditions $\mathbf{u}_k = \mathbf{u}_\Gamma$ still hold along Γ and the rotation tensor \mathbf{Q}_Γ of Γ is defined again by two stiffly connected branches M_1 and M_2 , so that $\mathbf{Q}_1 = \mathbf{Q}_2 = \mathbf{Q}_\Gamma$. But now the branch M_3 is assumed to be connected along the junction Γ in some deformable manner, Fig. 5.

The junction of M_3 is called *deformable* along Γ if, besides of the continuity conditions given above, the edge couple vector $\mathbf{m}_3 = \mathbf{M}_3 \mathbf{v}_3 \in E$ depends on $\mathbf{Q}_3, \mathbf{Q}'_3$ and/or $\delta \mathbf{Q}_3$ as follows:

$$\mathbf{m}_3 = \hat{\mathbf{m}}_3(\mathbf{Q}_3, \mathbf{Q}'_3, \delta \mathbf{Q}_3) \neq \mathbf{0}, \quad (32)$$

where $(\cdot)' = \frac{d}{ds}(\cdot)$ is derivative along Γ . Of course, higher-order derivatives and higher-order variations of \mathbf{Q}_3 may enter the function $\hat{\mathbf{m}}_3$ as well, if necessary.

Let us discuss in more detail the influence of separate ingredients of the function $\hat{\mathbf{m}}_3$ on the form of S-JI integral of (21).

5.1. Elastic junction

The junction of M_3 is called *elastic* along Γ if \mathbf{m}_3 in (32) depends on \mathbf{Q}_3 alone,

$$\mathbf{m}_3 = \hat{\mathbf{m}}_3(\mathbf{Q}_3). \quad (33)$$

Using the results of Section 4.3, the moment terms in the S-JI integral with account of (33) can be given by

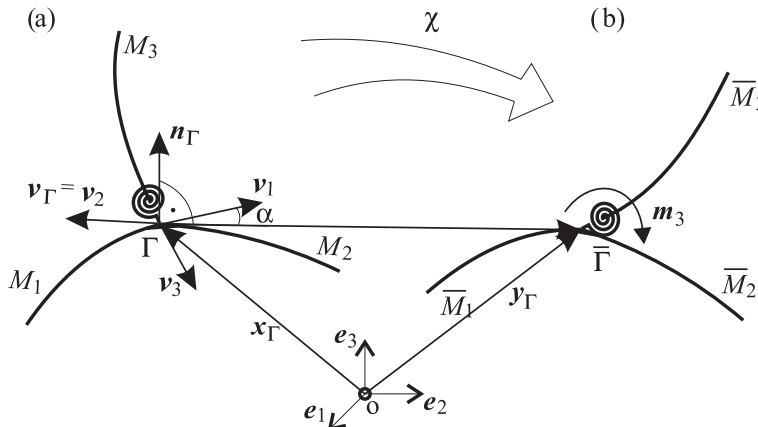

Fig. 5. The junction of M_3 in undeformed (a) and deformed (b) placements.

$$\begin{aligned} \llbracket \mathbf{M}\mathbf{v} \cdot \boldsymbol{\omega} \rrbracket &= \{(\mathbf{M}_2 - \mathbf{M}_1 \cos \alpha)\mathbf{v}_\Gamma\} \cdot \boldsymbol{\omega}_\Gamma + \hat{\mathbf{m}}_3(\mathbf{Q}_3) \cdot \boldsymbol{\omega}_3, \\ \llbracket \mathbf{M}\mathbf{v} \rrbracket \cdot \boldsymbol{\omega}_\Gamma &= \{(\mathbf{M}_2 - \mathbf{M}_1 \cos \alpha)\mathbf{v}_\Gamma\} \cdot \boldsymbol{\omega}_\Gamma + \hat{\mathbf{m}}_3(\mathbf{Q}_3) \cdot \boldsymbol{\omega}_\Gamma. \end{aligned} \quad (34)$$

For the elastic junctions of M_3 the S-JI integral in the PVW (21) should be replaced by

$$\text{S-JI} = \int_\Gamma \hat{\mathbf{m}}_3(\mathbf{Q}_3) \cdot (\boldsymbol{\omega}_3 - \boldsymbol{\omega}_\Gamma) ds. \quad (35)$$

For some elastic junctions it is more appropriate to use the linear function $\hat{\mathbf{m}}_3$,

$$\mathbf{m}_3 = \mathbb{A} \cdot \mathbf{Q}_3 = \mathbf{A}\phi_3, \quad (36)$$

where \mathbb{A} and \mathbf{A} are given 3rd-order and 2nd-order junction stiffness tensors, respectively, composed of scalar coefficients, and $\phi_3 = \phi\mathbf{i}$ is the equivalent finite rotation vector of \mathbf{Q}_3 with ϕ as the angle of rotation about the rotation axis defined by the unit vector \mathbf{i} . For such *linearly elastic* junction of M_3 the S-JI integral becomes

$$\text{S-JI} = \int_\Gamma (\mathbb{A} \cdot \mathbf{Q}_3) \cdot (\boldsymbol{\omega}_3 - \boldsymbol{\omega}_\Gamma) ds = \int_\Gamma \phi(\mathbf{A}\mathbf{i}) \cdot (\boldsymbol{\omega}_3 - \boldsymbol{\omega}_\Gamma) ds. \quad (37)$$

5.2. Non-locally elastic junction

The junction of M_3 is called *non-locally elastic* along Γ if \mathbf{m}_3 in (32) depends on \mathbf{Q}'_3 alone,

$$\mathbf{m}_3 = \hat{\mathbf{m}}_3(\mathbf{Q}'_3). \quad (38)$$

Let us take into account that $\mathbf{Q}'_3 \mathbf{Q}'_3 = -(\mathbf{Q}'_3 \mathbf{Q}'_3)^T$ is the skew tensor expressible through its axial vector $\boldsymbol{\kappa}_3$ by, see Pietraszkiewicz and Badur (1983, f. (4.22)),

$$\mathbf{Q}'_3 \mathbf{Q}'_3 = \boldsymbol{\kappa}_3 \times \mathbf{1}, \quad \boldsymbol{\kappa}_3 = \phi' \mathbf{i} + \{\sin \phi \mathbf{1} - (1 - \cos \phi) \mathbf{i} \times \mathbf{1}\} \mathbf{i}', \quad (39)$$

so that (38) can equivalently be expressed by

$$\mathbf{m}_3 = \hat{\mathbf{m}}_3\{\mathbf{Q}_3(\boldsymbol{\kappa}_3 \times \mathbf{1})\} = \tilde{\mathbf{m}}_3(\boldsymbol{\kappa}_3). \quad (40)$$

For the non-locally elastic junction the S-JI integral takes the form

$$\text{S-JI} = \int_\Gamma \hat{\mathbf{m}}_3(\mathbf{Q}'_3) \cdot (\boldsymbol{\omega}_3 - \boldsymbol{\omega}_\Gamma) ds = \int_\Gamma \tilde{\mathbf{m}}_3(\boldsymbol{\kappa}_3) \cdot (\boldsymbol{\omega}_3 - \boldsymbol{\omega}_\Gamma) ds. \quad (41)$$

If, in particular, the functions $\hat{\mathbf{m}}_3$ in (38) and $\tilde{\mathbf{m}}_3$ in (40) are linear, then

$$\mathbf{m}_3 = \mathbb{G} \cdot \mathbf{Q}'_3 = \mathbf{G}\boldsymbol{\kappa}_3, \quad (42)$$

where now \mathbb{G} and \mathbf{G} are known 3rd-order and 2nd-order stiffness tensors composed of scalar coefficients, respectively. For such *non-locally linearly elastic* junction the S-JI integral reads

$$\text{S-JI} = \int_\Gamma (\mathbb{G} \cdot \mathbf{Q}'_3) \cdot (\boldsymbol{\omega}_3 - \boldsymbol{\omega}_\Gamma) ds = \int_\Gamma (\mathbf{G}\boldsymbol{\kappa}_3) \cdot (\boldsymbol{\omega}_3 - \boldsymbol{\omega}_\Gamma) ds. \quad (43)$$

5.3. Dissipative junction

The deformable junction of M_3 can be called *dissipative* along Γ if \mathbf{m}_3 in (32) depends on $\delta\mathbf{Q}_3$ alone,

$$\mathbf{m}_3 = \hat{\mathbf{m}}_3(\delta\mathbf{Q}_3). \quad (44)$$

Taking again into account that $\mathbf{Q}_3^T \delta\mathbf{Q}_3 = -(\mathbf{Q}_3^T \delta\mathbf{Q}_3)^T$ is the skew tensor expressible through its axial vector $\boldsymbol{\omega}_3$ by

$$\begin{aligned} \mathbf{Q}_3^T \delta\mathbf{Q}_3 &= \boldsymbol{\omega}_3 \times \mathbf{1}, \\ \boldsymbol{\omega}_3 &= (\delta\phi) \mathbf{i} + \{\sin \phi \mathbf{1} - (1 - \cos \phi) \mathbf{i} \times \mathbf{1}\} \delta\mathbf{i}, \end{aligned} \quad (45)$$

the relation (44) can equivalently be expressed by

$$\mathbf{m}_3 = \hat{\mathbf{m}}_3\{\mathbf{Q}_3(\boldsymbol{\omega}_3 \times \mathbf{1})\} = \bar{\mathbf{m}}_3(\boldsymbol{\omega}_3). \quad (46)$$

In this case the S-JI integral takes the form

$$\text{S-JI} = \int_\Gamma \hat{\mathbf{m}}_3(\delta\mathbf{Q}_3) \cdot (\boldsymbol{\omega}_3 - \boldsymbol{\omega}_\Gamma) ds = \int_\Gamma \bar{\mathbf{m}}_3(\boldsymbol{\omega}_3) \cdot (\boldsymbol{\omega}_3 - \boldsymbol{\omega}_\Gamma) ds. \quad (47)$$

If, in particular, the functions $\hat{\mathbf{m}}_3$ in (44) and $\bar{\mathbf{m}}_3$ in (46) are linear, then

$$\mathbf{m}_3 = \mathbb{H} \cdot \delta\mathbf{Q}_3 = \mathbf{H}\boldsymbol{\omega}_3, \quad (48)$$

where again \mathbb{H} and \mathbf{H} are known 3rd-order and 2nd-order stiffness tensors composed of scalar coefficients, respectively. For such *linearly dissipative* junction the S-JI integral becomes

$$\begin{aligned} \text{S-JI} &= \int_\Gamma (\mathbb{H} \cdot \delta\mathbf{Q}_3) \cdot (\boldsymbol{\omega}_3 - \boldsymbol{\omega}_\Gamma) ds \\ &= \int_\Gamma (\mathbf{H}\boldsymbol{\omega}_3) \cdot (\boldsymbol{\omega}_3 - \boldsymbol{\omega}_\Gamma) ds. \end{aligned} \quad (49)$$

6. Conclusions

It has been shown that the unique 2D kinematics of the branching shell consists of the translation vector \mathbf{u} and rotation tensor \mathbf{Q} fields defined on the regular parts of the shell base surface as well as of independent fields $\mathbf{u}_\Gamma, \mathbf{Q}_\Gamma$ defined only along the singular surface Γ modelling the shell branching.

For the branching shell we have derived the 2D principle of virtual work (21), in which different types of junctions are taken into account by appropriate forms of the shell-junction interaction integral. It has been found that the S-JI integral vanishes for the stiff, entirely simply connected and partly simply supported junctions. In case of deformable junctions, the S-JI integral has been explicitly calculated for the elastic and dissipative junctions as well as for the non-locally elastic junction, and their particular linear behaviour is characterized as well.

The 2D principle of virtual work (21), with S-JI integrals corresponding to the particular type of junctions along Γ , may be used to develop appropriate computer programs for analyses of branching shells with various types of junctions.

Acknowledgement

This research was supported by the Polish Ministry of Science and Higher Education with the Grant No. N501 0073 33.

References

- Chróścielewski, J., Makowski, J., Pietraszkiewicz, W., 2004. Statics and Dynamics of Multi-Shells: Nonlinear Theory and Finite Element Method (in Polish). Wydawnictwo IPPT PAN, Warszawa.
- Chróścielewski, J., Makowski, J., Stumpf, H., 1992. Genuinely resultant shell finite elements accounting for geometric and material non-linearity. International Journal for Numerical Methods in Engineering 35, 63–94.
- Chróścielewski, J., Makowski, J., Stumpf, H., 1997. Finite element analysis of smooth, folded and multi-shell structures. Computer Methods in Applied Mechanics and Engineering 141, 1–46.
- Cosserat, E., Cosserat, F., 1909. Théorie des Corps Deformables. Paris: Herman et Flis. English translation: NASA TT F-11, vol. 561, NASA, Washington, DC, 1968.
- Eremeyev, V.A., Pietraszkiewicz, W., 2006. Local symmetry group in the general theory of elastic shells. Journal of Elasticity 85, 125–152.
- Konopińska, V., 2007. Continuity Conditions at Singular Curves in the Non-Linear Mechanics of Shells. Ph. D. thesis, Oprac. wewn. IMP PAN Nr 7360/07 Gdańsk (in Polish).
- Konopińska, V., Pietraszkiewicz, W., 2007. Exact resultant equilibrium conditions in the non-linear theory of branching and self-intersecting shells. International Journal of Solids and Structures 44, 352–369.
- Libai, A., Simmonds, J.G., 1983. Nonlinear elastic shell theory. In: Hutchinson, J.W., Wu, T.Y. (Eds.), Advances in Applied Mechanics, vol. 23. Academic Press, New York, pp. 271–371.
- Libai, A., Simmonds, J.G., 1998. The Nonlinear Theory of Elastic Shells, second ed. University Press, Cambridge.
- Makowski, J., Stumpf, H., 1990. Buckling equation for elastic shells with rotational degrees of freedom undergoing finite strain deformation. International Journal of Solids and Structures 26, 353–368.
- Makowski, J., Stumpf, H., 1994. Mechanics of Irregular Shell Structures. Institut für Mechanik, Ruhr-Universität, Mitteilung Nr 95, Bochum, pp. 1–206.

- Pietraszkiewicz, W., Badur, J., 1983. Finite rotations in the description of continuum deformation. *International Journal of Engineering Science* 21 (9), 1097–1115.
- Pietraszkiewicz, W., 2001. Nonlinear theories of shells. In: Woźniak, C. (Ed.), *Mechanics of Elastic Plates and Shells*. PWN, Warszawa, pp. 424–497 (in Polish).
- Pietraszkiewicz, W., Chróścielewski, J., Makowski, J., 2005. On dynamically and kinematically exact theory of shells. In: Pietraszkiewicz, W., Szymczak, Cz. (Eds.), *Shell Structure: Theory and Applications*. Taylor & Francis, London, pp. 163–167.
- Reissner, E., 1974. Linear and nonlinear theory of shells. In: Fung, Y.C., Sechler, E.E. (Eds.), *Thin Shell Structures*. Prentice-Hall, Englewood Cliffs, pp. 29–44.
- Reissner, E., 1982. A note on two-dimensional finite deformation theories of shells. *International Journal of Non-Linear Mechanics* 17 (3), 217–221.