

DETERMINATION OF LEAKAGE INDUCTANCES OF MULTI-WINDING AND SINGLE-PHASE TRANSFORMER

Andrzej WILK¹, Rafał POKOŃSKI²

1. Politechnika Gdańska, ul. G. Narutowicza 11/12, 80-233 Gdańsk
tel: 058 347 1087 fax: 058 341 0880 e-mail: awilk@ely.pg.gda.pl
2. Politechnika Gdańska, ul. G. Narutowicza 11/12, 80-233 Gdańsk
tel: 058 347 6075 fax: 058 341 0880 e-mail: rpokonski@ely.pg.gda.pl

Abstract: This paper presents the method for determination of leakage inductances of single-phase and multi-winding transformer. The matrix of leakage inductances takes into account leakage self and also leakage mutual magnetic couplings. It is assumed that there is a flux common to all windings and several leakage fluxes referred to a particular winding. The flux linkages of each coil needed for calculation of leakage inductances was computed by FEM commercial software Opera 3D. The values of leakage inductances matrix have been calculated for special reduced scale traction, 19.3 kVA transformer. This is core type construction transformer with eight windings.

Keywords: single-phase transformer, FEM simulation, leakage inductance.

1. INTRODUCTION

The leakage inductances presented in this paper are referenced to the core structure of reduced scale traction transformer RSTT with tape wound core (Figure 1).

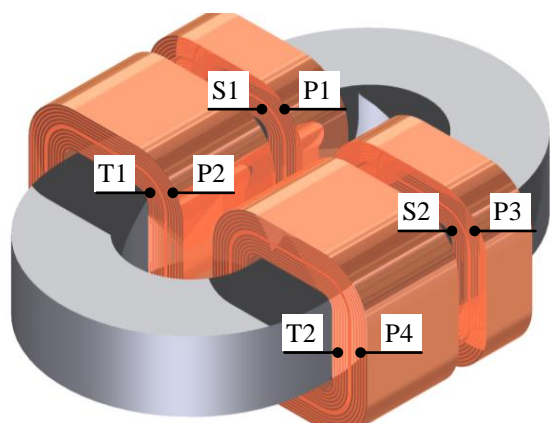

Fig. 1. 3D computer model of single-phase transformer that has the core and 8 windings arranged in the core type construction: P1, P2, P3, P4 – primary windings; S1, S2, T1, T2 – secondary windings

Single-phase transformers used in electric traction can have from 8 to 16 windings. A structure shown in Figure 1 is assembled with tape wound iron core and 8 coils symmetrically distributed on the two columns. Transformer plates in yoke part are curved in a circle shape. The cross-section of the core in column and yoke areas is a square with 100 mm side. The apparent powers of P2, P4, T1 and T2 coils are 6.4 kVA, with rated voltage 230 V. The apparent powers of P1, P3, S1, S1 and S2 coils are 3.2 kVA, with rated voltage 115 V. Rated current of all coils is the same - 28 A. Coils P1, P2, P3 and P4 belong to the primary side, and the other to the secondary side of transformer.

All windings are magnetically coupled. A portion of magnetic flux partially closes by the area outside the core. This part of magnetic flux gives an essential contribution to the so-called leakage fluxes of particular coils. These fluxes are referenced to the transformer's leakage inductance in longitudinal branch of equivalent scheme.

Determination of the leakage inductance of multi-winding transformer by analytical approach is given in [1]. The currently used FEM simulators allow for a more accurate calculation of inductance. Methodology for calculating the transformer leakage inductances by the FEM simulation (calculations in 2D) can be found in [2].

Dynamic magnetizing inductance of RSTT has been determined by FEM simulations in 3D space are presented in [3]. The considerations in this paper are mainly referenced to leakage inductance matrix.

Chapter 2 presents a mathematical model of RSTT that takes into account leakage inductance matrix. Chapter 3 shows the values of the inductance matrix obtained from the FEM simulations. Discussion of the results and important findings have been given in the summary.

2. MATHEMATICAL MODEL OF TRANSFORMER

Figure 2 presents a schematic approach of RSTT transformer in the form of an electromagnetic multi-winding transducer. In this diagram the voltages at the terminals of each winding and the currents flowing in each coil have been indicated. There is a lack on this figure of the equivalent circuit representing the eddy current loss and hysteresis. RSTT

mathematical model that takes into account the equivalent circuit for hysteresis and eddy currents by time variant dissipative element is presented in [4].

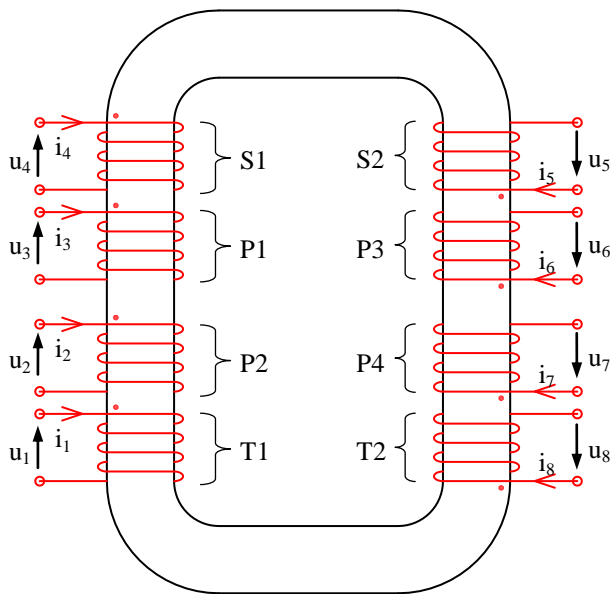

Fig. 2. Diagram of multi-winding and single-phase transformer with indicated voltages and currents of particular coils

A mathematical model of transformer with K windings (coils) at low frequencies formulated on the basis of Kirchoff's loop law is described by the equation

$$\mathbf{u} = \mathbf{R}\mathbf{i} + \frac{d}{dt} \Psi(\mathbf{i}), \quad (1)$$

where: $\mathbf{u} = [u_1 \ u_2 \ \dots \ u_K]^T$ – voltages vector at the terminals of the particular coils, $\mathbf{i} = [i_1 \ i_2 \ \dots \ i_K]^T$ – vector of currents flowing in the particular windings, \mathbf{R} – matrix of resistances of particular coils, $\Psi(\mathbf{i}) = [\Psi(\mathbf{i})_1 \ \Psi(\mathbf{i})_2 \ \dots \ \Psi(\mathbf{i})_K]^T$ – vector of flux linkages of particular windings.

From equation (1) the vector of currents \mathbf{i} can be determined if vector of voltages $\mathbf{u}(t)$ is defined as time function. The accuracy of the model depends on the accuracy of determination of $\Psi(\mathbf{i})$ as nonlinear function of vector of currents \mathbf{i} and accuracy of determination of the resistances of the coils.

Flux linkage coupled with the particular winding is strongly non-linear function of all winding currents. The derivative of the vector $\Psi(\mathbf{i})$ with respect to time yields voltage induced in each winding. The total time derivative of $\Psi(\mathbf{i})$ as complex function can be expressed as formula including matrix of dynamic inductance \mathbf{L}_d composed of the self and mutual inductances. The result of time differentiation is given by

$$\frac{d}{dt} \Psi(\mathbf{i}(t)) = \begin{bmatrix} \frac{\partial \Psi_1}{\partial i_1} & \dots & \frac{\partial \Psi_1}{\partial i_K} \\ \vdots & & \vdots \\ \frac{\partial \Psi_K}{\partial i_1} & \dots & \frac{\partial \Psi_K}{\partial i_K} \end{bmatrix} \frac{d}{dt} \begin{bmatrix} i_1 \\ \vdots \\ i_K \end{bmatrix} = \mathbf{L}_d(\mathbf{i}) \frac{d}{dt} \mathbf{i} \quad (2)$$

It may be assumed that the flux linkage contains strongly non-linear components due to the magnetization characteristics of the core and approximately linear

components resulting from the leakage flux. With this assumption a flux linkage of each k -th winding may be represented by formula

$$\Psi_k(\mathbf{i}) = N_k \Phi_k(\Theta(\mathbf{i})) + \sum_{n=1}^K L_{\sigma,k,n} i_n, \quad k, n = 1, 2, \dots, K, \quad (3)$$

where Φ_k is the main magnetic flux (represented only by closed lines in the core) coupled with the winding number k , Θ is the vector of magnetomotive forces of particular coils $L_{\sigma,k,n}$ is the leakage inductance resulting from the existence of the leakage flux coupled to the coil k induced by the current in the winding n , N_k is the number of turns of the k -th coil.

Due to the core construction of tested transformer additional simplifying assumption has been taken involving the distribution of magnetic flux on the common flux Φ_c for all coils and a sum of leakage fluxes. Under this assumption flux linkages of each winding can be represented in the following form

$$\Psi_k(\mathbf{i}) = N_k \Phi_c(\Theta(\mathbf{i})) + \sum_{n=1}^K L_{\sigma,k,n} i_n, \quad k, n = 1, 2, \dots, K, \quad (4)$$

where Φ_c is a magnetic flux common to all windings

Significant facilitate of calculation of dynamic inductance matrix can be achieved by representing a common flux as a function of the total magnetomotive force of all windings

$$\Theta(\mathbf{i}) = N_1 i_1 + N_2 i_2 + \dots + N_K i_K \quad (5)$$

On this basis, the matrix \mathbf{L}_d is defined by the equation

$$\mathbf{L}_d = \frac{\partial \Phi_c}{\partial \Theta} \begin{bmatrix} N_1 N_1 & N_1 N_2 & \dots & N_1 N_K \\ N_2 N_1 & N_2 N_2 & \dots & N_2 N_K \\ \vdots & \vdots & & \vdots \\ N_K N_1 & N_K N_2 & \dots & N_K N_K \end{bmatrix} + \begin{bmatrix} L_{\sigma,1,1} & L_{\sigma,1,2} & \dots & L_{\sigma,1,K} \\ L_{\sigma,2,1} & L_{\sigma,2,2} & \dots & L_{\sigma,2,K} \\ \vdots & \vdots & & \vdots \\ L_{\sigma,K,1} & L_{\sigma,K,2} & \dots & L_{\sigma,K,K} \end{bmatrix}, \quad (6)$$

where a derivative of common flux Φ_c with respect to total of magnetomotive force is a common non-linear factor of magnetizing inductance for all windings.

3. MATRIX OF LEAKAGE INDUCTANCES

The second component of the right side of equation (6) represents the leakage inductance matrix. To determine the elements of the matrix the common flux $\Phi_c(\Theta)$ as a function of the total magnetomotive force is needed. This characteristic is shown in Figure 3 as set of discrete points and approximated by set of cubic splines. Calculations were made on the basis of FEM simulations in 3D space using Opera 3D software. A method of determining $\Phi_c(\Theta)$ and implementation of RSTT FEM model are given in detail in [3].

For determination of leakage inductances of particular k -th winding the characteristic of fluxes difference (between the total flux linkages of k -th winding and flux linkages of k -th winding based on common magnetic flux excited by current in n -th winding) has been calculated.

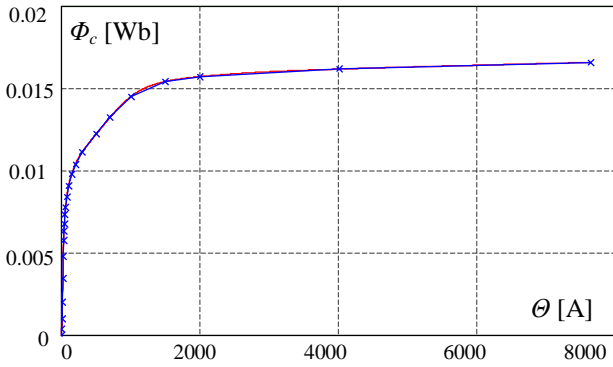

Fig 3. Characteristic of common flux $\Phi_c(\Theta)$ to all windings versus total magnetomotive force

In case of P2 winding these characteristics of differences are determined from the equations

$$\begin{aligned}
 \Psi_{\sigma P2}(\Theta_{P2}) &= \Psi_{P2}(\Theta_{P2}) - N_{P2}\Phi_c(\Theta_{P2}), \\
 \Psi_{\sigma P2}(\Theta_{T1}) &= \Psi_{P2}(\Theta_{T1}) - N_{P2}\Phi_c(\Theta_{T1}), \\
 \Psi_{\sigma P2}(\Theta_{P1}) &= \Psi_{P2}(\Theta_{P1}) - N_{P2}\Phi_c(\Theta_{P1}), \\
 \Psi_{\sigma P2}(\Theta_{S1}) &= \Psi_{P2}(\Theta_{S1}) - N_{P2}\Phi_c(\Theta_{S1}), \\
 \Psi_{\sigma P2}(\Theta_{P3}) &= \Psi_{P2}(\Theta_{P3}) - N_{P2}\Phi_c(\Theta_{P3}), \\
 \Psi_{\sigma P2}(\Theta_{P4}) &= \Psi_{P2}(\Theta_{P4}) - N_{P2}\Phi_c(\Theta_{P4}), \\
 \Psi_{\sigma P2}(\Theta_{S2}) &= \Psi_{P2}(\Theta_{S2}) - N_{P2}\Phi_c(\Theta_{S2}), \\
 \Psi_{\sigma P2}(\Theta_{T2}) &= \Psi_{P2}(\Theta_{T2}) - N_{P2}\Phi_c(\Theta_{T2}),
 \end{aligned} \quad (7)$$

where: $\Psi_{\sigma P2}(\Theta_{P2})$, $\Psi_{\sigma P2}(\Theta_{T1})$, $\Psi_{\sigma P2}(\Theta_{P1})$, $\Psi_{\sigma P2}(\Theta_{S1})$, $\Psi_{\sigma P2}(\Theta_{P3})$, $\Psi_{\sigma P2}(\Theta_{P4})$, $\Psi_{\sigma P2}(\Theta_{S2})$, $\Psi_{\sigma P2}(\Theta_{T2})$, mean flux linkages of P2 winding as functions of magnetomotive force of the winding P2, T1, P1, S1, P3, P4, S2, and T2 respectively.

Plots of characteristics defined by equation (7) are shown in Figure 4. With these charts, it is easy to determine the leakage inductances related to P2 winding using the appropriate difference quotients. Similar relations, as in equations (7) have been formulated for the other windings.

Characteristics presented in Figure 4 are non-linear. Roughly it can be concluded that they are linear only in some ranges of magnetomotive force.

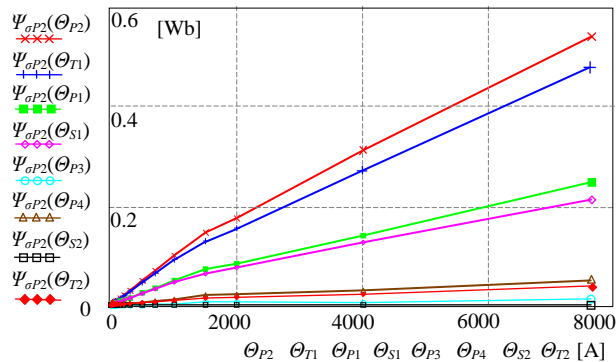

Fig.4. Characteristics of leakage flux $\Psi_{\sigma P2}$ coupled with P2 winding versus magnetomotive forces Θ_{P2} , Θ_{T1} , Θ_{P1} , Θ_{S1} , Θ_{P3} , Θ_{P4} , Θ_{S2} , and Θ_{T2} accordingly of P2, T1, P1, S1, P3, P4, S2, and T2 windings

Particular characteristics have greater and approximately constant slope for the magnetomotive force in the range from 0 to 1500 A. When the value of

magnetomotive force is greater than 2000 A the slope of particular characteristics decreases and can be assumed as constant. According to the accepted assumption of the leakage inductance linearity the difference quotients $\Delta\Psi_{\sigma} / \Delta\Theta$ has been used to calculate the inductances for the second range of the magnetomotive force values. Based on these ratios and taking into account the number of turns, the leakage inductances referenced to P2 winding and to other windings have been determined.

On the basis of the same procedure and taking into account the number of turns appropriate for each winding, leakage inductances of remaining winding of RSTT have been determined. Leakage inductance components of the reference RSTT mathematical model expressed in matrix form presents the equation

$$\begin{bmatrix} L_{\sigma,1,1} & L_{\sigma,1,2} & \cdots & L_{\sigma,1,8} \\ L_{\sigma,2,1} & L_{\sigma,2,2} & \cdots & L_{\sigma,2,8} \\ \vdots & \vdots & & \vdots \\ L_{\sigma,8,1} & L_{\sigma,8,2} & \cdots & L_{\sigma,8,8} \end{bmatrix} = 10^{-3} \begin{bmatrix} 13,7 & 12,2 & 2,93 & 2,77 & 0 & 0,08 & 1,0 & 0,84 \\ 12,2 & 13,7 & 3,05 & 2,81 & 0,024 & 0,1 & 1,23 & 1,0 \\ 2,93 & 3,05 & 4,26 & 3,53 & 0,297 & 0,40 & 0,1 & 0,08 \\ 2,77 & 2,81 & 3,53 & 4,02 & 0,21 & 0,29 & 0,024 & 0 \\ 0 & 0,024 & 0,297 & 0,21 & 4,02 & 3,53 & 2,81 & 2,77 \\ 0,08 & 0,1 & 0,40 & 0,29 & 3,53 & 4,26 & 3,06 & 2,93 \\ 1,0 & 1,23 & 0,1 & 0,024 & 2,81 & 3,06 & 13,7 & 12,2 \\ 0,84 & 1,0 & 0,08 & 0 & 2,77 & 2,93 & 12,2 & 13,7 \end{bmatrix} \quad (8)$$

The matrix (8) is symmetric with respect to the main diagonal. Some inductances differ by a several orders of value. As expected the highest value of leakage inductance occurs when leakage flux linkages of winding is induced by the current flowing in this winding. In that case the inductances are noted as self leakage inductances. The values of self leakage inductances lie on the main diagonal of the matrix (8). The final value of inductance also depends on the number of turns, hence significant differences of L_{σ} arise between the traction windings (P2, P4, T1 and T2) and auxiliary windings (P1, P3, S1 and S2). Traction windings have twice number of turns as the auxiliary windings. It should be noted that the some mutual leakage inductances have lower but still significant values compared to self inductances. Mutual leakage inductances are located outside the main diagonal of matrix (8).

In Figure 5 values of individual leakage inductances from matrix (8) have been presented by means of 3D bar plot to better evaluation of ratios between components. On the axes of "Rows" and "Columns" there are symbolic designations of windings according to Figure 1. It allows for a better assessment of the relationship between particular leakage inductances components. From the analysis of the matrix (8) and Figure 5 it can be concluded that leakage inductances resulting from the interaction between the windings of the (P2-T1, P4-T2, P1-S1, P3-S2) located on the same column and at the same height is slightly less than the self leakage inductances.

Smaller, but still significant values of matrix elements (8) are revealed by the mutual interactions between the windings arranged on the same column, but at different heights (P2-P1,

P4-P3, S1-T1 and S2-T2, etc.). Neglect of these leakage fluxes can lead to significant errors in the accurate circuit simulations.

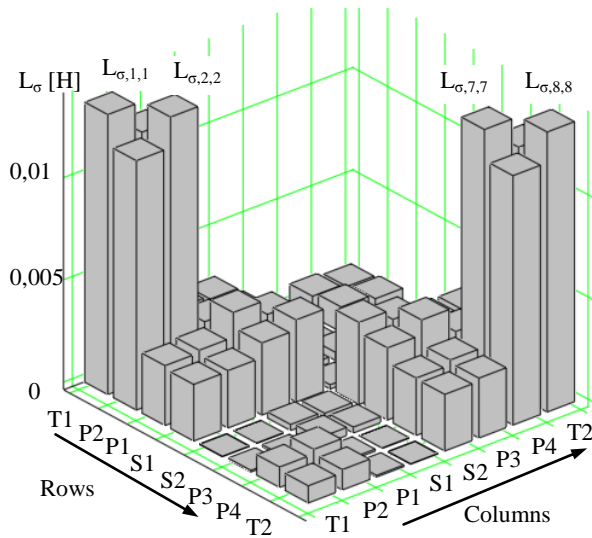

Fig.5. Values of leakage inductances matrix of RSTT transformer model as a 3D bar plot.

Mutual leakage inductances between the windings symmetrically arranged on separate columns (P2-P4, T1-T2, P1-P3, S1-S2) are generally about one order of value lower. However, they can be important in some circuit simulations.

The lowest values of matrix (8) components are observed in the interactions between windings arranged in different columns and different levels (P1-P 4, P2-P3, S2 T1-, T2-S1, etc.).

4. CONCLUSIONS

In mathematical model of the transformer, magnetic flux coupled with a particular winding can be decomposed into a common flux to all windings and other fluxes surrounding the winding and having the core for a part of its path. Thank to this it is able to represent the matrix of dynamic induction as a sum of two matrices. The first component of this sum represents highly nonlinear self-

inductances and mutual inductances resulting from magnetization of the iron core. The second component of this sum represents the leakage inductance matrix. Leakage inductance matrix elements can be approximated as independent of the current value.

The values of the matrix components have been determined on the calculation of the difference between the total flux linkage coupled with the winding and the flux linkages of this winding resulting from common flux. To accurate determining of flux linkage characteristics versus magnetomotive force, 3D FEM simulations have been executed. Only reversible characteristic of core magnetizing have been taken into account. Leakage inductance matrix contains self-inductances and mutual inductances components. Self-inductances have the greatest values, but the mutual leakage inductances are important for accurate circuit simulations. The analysis shows that the mutual leakage inductances between windings arranged on the same column may be important in some types of circuit simulation. Leakage inductances between windings arranged on different columns and different levels can be neglected.

5. REFERENCES

1. Hayek J.El., Sobczyk T.J.: Analytic one-dimensional design method for railways traction transformers. International Electric Machines & Drives Conference IEMDC'03, Madison, WI, USA, 1-4 June 2003, pp. 1760-1765.
2. Hayek J. El., Sobczyk T. J.: Equivalent circuit of multi-windings traction transformers including magnetizing currents. Proceedings of the Eighth International Conference on Electrical Machines and Systems, ICEMS 2005, Nanjing, China, 27-29 Sept. 2005, pp. 1740-1745
3. Wilk A.: Nonlinear modeling of traction transformer with coiled iron core for dynamic simulation. The Scientific Papers of Faculty of Electrical and Control Engineering, Gdansk University of Technology, No. 26, Gdansk 2009, pp. 125-128.
4. Wilk A., Nieznanski J., Moson I.: Nonlinear model of a wound iron core traction transformer with the account of magnetic hysteresis. IEEE XIX International Conference on Electrical Machines (ICEM2010), Rome, Italy, 6-8 September 2010, 7 pp

WYZNACZANIE REAKTANCJI ROZPROSZENIA CEWEK ELEMENTARNYCH TRANSFORMATORA JEDNOFAZOWEGO

Słowa kluczowe: transformator jednofazowy, symulacja polowa, indukcyjności rozproszenia.

Streszczenie: W referacie przedstawiono sposób wyznaczania indukcyjności rozproszenia cewek elementarnych transformatora jednofazowego na podstawie obliczeń elektromagnetycznych. Wyznaczono indukcyjności rozproszenia własne i wzajemne. Pojęcie indukcyjności własnej ujmuje strumień rozproszenia sprzęgający się z cewką wzbudzany przez prąd tej cewki. Pojęcie indukcyjności wzajemnej obejmuje strumień rozproszenia sprzęgający się z cewką wzbudzany przez prądy innych cewek. Wartości indukcyjności rozprożeń są ważnym parametrem obwodowym transformatora mającym istotny wpływ na stany przejściowe i ustalone. Obliczenia wykonano w odniesieniu do transformatora o mocy 19,3 kVA o konstrukcji rdzeniowej, który zawiera osiem uzwojeń. Rozkład pola magnetycznego wyznaczono na drodze symulacji polowej przy wykorzystaniu programu Opera 3D. Indukcyjności wyznaczono na podstawie analiz strumieni sprzężonych z cewkami w funkcji prądów w poszczególnych cewkach.