

METHOD AND MEASUREMENT SYSTEM FOR DC CHARACTERISTICS MEASUREMENT OF POWER DIODES IN VERY WIDE CURRENT RANGE

Jacek CICHOSZ, Arkadiusz SZEWCZYK, Barbara STAWARZ-GRACZYK

Gdansk University of Technology, Faculty of Electronics, Telecommunications and Informatics
Department of Metrology and Optoelectronics, 11/12 G. Narutowicza Street, 80-233 Gdansk, Poland
tel: 58 347 14 84 fax: 58 348 63 73 e-mail: jcichosz@eti.pg.gda.pl

Abstract: The new measurement set-up of DC characteristics of power diodes measurements was presented. Authors proposed to organize measurements in a pulse manner, because in typical method junction temperature of power diodes under test during measurements increase. The system elaborated on the base of method for measuring DC in a very wide current range which utilizes modified $R-2R$ resistor ladder (short-circuit keys instead of switching keys) was constructed. The measurement system is controlled by the computer with LabView application that allows to apply measurement procedure in a very short time.

Key-words: SiC power diode, measurement, DC characteristic.

1. INTRODUCTION

The measurements of DC characteristics of power semiconductor devices require wide voltage and current range polarization of the device under test (DUT). Additionally, during the measurement procedure the increase of a junction temperature and visible change of measured DC characteristic are observed. That is why it is important to keep constant DUT temperature during the measurement. The described phenomenon of increasing junction temperature occurs especially in elements with high temperature coefficient, for example in silicon carbide (SiC) power elements [1, 2]. The most popular application of SiC material is for switching elements as diodes and transistors that can work with higher switching frequencies and higher junction temperature, up to 175°C. The most popular DC characteristics measurement methods are:

- oscilloscope method, which bases on element stimulation with sinusoidal signal and observation of the characteristic,
- continuous method with DC stimulation.

Both methods can be applied in limited voltage and current ranges. In order to limit the power lost in DUT during the DC measurement, for higher values of current (several amps) the pulse measurement could be applied. The pulse measurement method is well known and is used in source-measure unit instruments and curve tracers, e.g. Tektronix's 371B, Agilent's B1505 and Keithley's 2600B series.

2. METHOD AND MEASUREMENT SYSTEM

The new method of a DC characteristic of power devices was proposed and on its base the measurement system was constructed. The method was checked on SiC power diodes.

The proposed new method of DC characteristics measurements is based on the rule of a sequential stimulation of DUT by current pulses of a very short duration. The stimulating pulses of current are fixed according to expected DC characteristics. It means that the stimulation is in a form of short current pulses of different values (amplitudes) and for this values of current the voltages on DUT are measured. This method does not cause the significant increase of the junction temperature. This method allows stimulating of DUT in a very short time and with a very high current values. Formally, the temperature during DC characteristics measurements is stable (invariable). The method can be applied for DC characteristics measurements of high power devices without their heating. The typical block diagram of power diodes DC characteristics measurement system is presented in figure 1 [3].

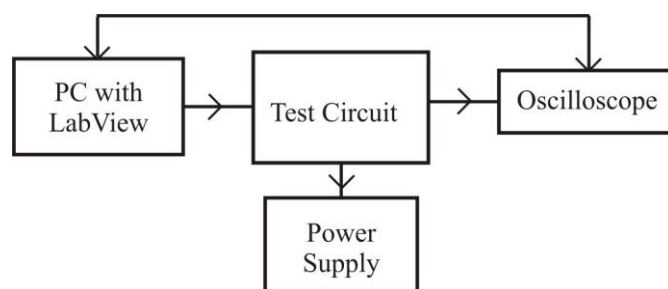

Fig. 1. Measurement system for power diodes DC characteristics

The most important part of this measurement system is the Test Circuit presented in details in figure 2.

It contains the power diode (DUT) and modified $R-2R$ resistor ladder marked as G due to which the changes in pulse amplitude of current can be applied.

The diode current I_d can be calculated from:

$$I_d = (U_1 - U_d) \cdot G_l \quad (1)$$

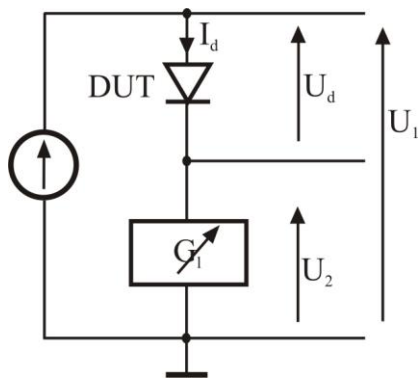

Fig. 2. Test circuit module, G_1 – modified resistor ladder R - $2R$, DUT – power diode, U_d – diode voltage, U_1 – power supply voltage, U_2 – measured voltage, I_d – diode current.

In this kind of system, the typical R - $2R$ resistor ladder presented in figure 3 was modified into a form presented in figure 4.

The output voltage U_{out} of this circuit is given by:

$$U_{out} = U_{ref} \cdot (a_1 2^{-1} + a_2 2^{-2} + \dots + a_n 2^{-n}) \quad (2)$$

where $a_i = 0$ if the switching key K_i is connected to the ground, $a_i = 1$ if the switching key K_i is connected to U_{ref} , $i = 1, 2, \dots, n$.

In the modified ladder (fig. 4) the resistance R is represented by conductance G . This replacement was realized for numerical calculations. The switching keys were replaced by short-circuit keys $K_1 - K_n$ (typical power MOSFETs).

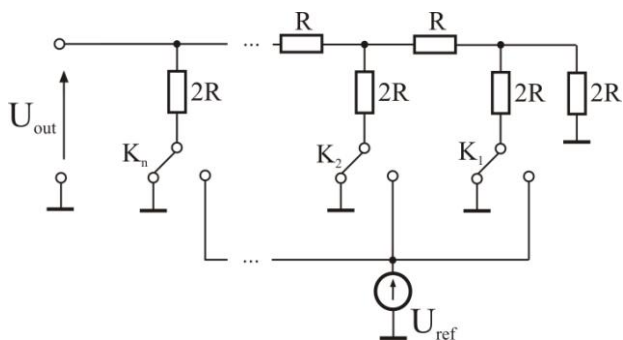

Fig. 3. R - $2R$ resistor ladder; U_{ref} – reference voltage, U_{out} – output voltage, K_n – switching keys

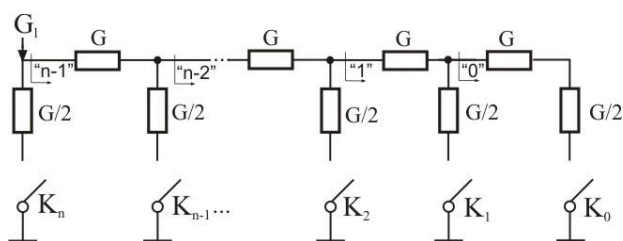

Fig. 4. Modified R - $2R$ resistor ladder, K_n – short-circuit keys

The output conductance of the ladder, G_1 depends on the number of switched on keys and is given by:

$$G_1 = \frac{1}{2} \cdot G \cdot a_n + G_{n-1} \quad (3)$$

where:

$$G_{n-1} = \frac{G \cdot (G/2 \cdot a_{n-1} + G_{n-2})}{G + G/2 \cdot a_{n-1} + G_{n-2}}, \quad (4)$$

$$G_{n-2} = \frac{G \cdot (G/2 \cdot a_{n-2} + G_{n-3})}{G + G/2 \cdot a_{n-2} + G_{n-3}}, \quad (5)$$

⋮

$$G_1 = \frac{G \cdot (G/2 \cdot a_1 + G_0)}{G + G/2 \cdot a_1 + G_0}, \quad (6)$$

$$G_0 = \frac{1}{3} \cdot G \cdot a_0. \quad (7)$$

$$K = 2^{a_n} + 2^{a_{n-1}} + \dots + 2^{a_1} + 2^{a_0}, \quad a_n = \begin{cases} 0 \\ 1 \end{cases}, \quad (8)$$

$a_n, a_k = 0$ if the short-circuit keys K_n and K_k are switched off, $a_n, a_k = 1$ if the short-circuit keys K_n and K_k are switched on, n is the last key number (equal to the total number of keys), $k = 2, 3, \dots, n-1$.

Depending on the number of branches n of the R - $2R$ resistor ladder, it is possible to carry out the measurement for 2^n different values of conductance.

The conductance and resistance characteristics of R - $2R$ ladder in the function of code word for 10 bits and the conductance equal to 1 S are presented in figure 5 and in figure 6.

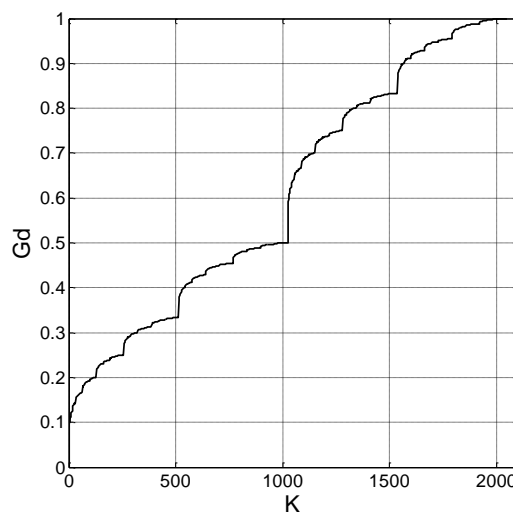

Fig. 5. The conductance characteristics for 10-bits R - $2R$ ladder

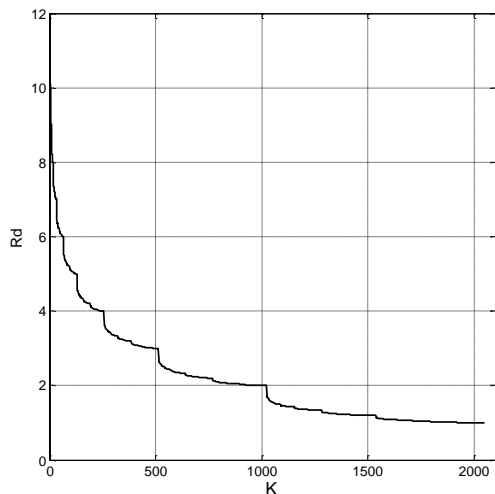

Fig. 6. The resistance characteristics for 10-bits R - $2R$ ladder

The conductance characteristic is similar to linear and it allows for even choosing measurement points for diode characteristic.

In the application of this new method the values of resistors in all branches were the same, and the single resistor has value 1Ω .

The measurement method was elaborated using a special LabView application for ladder controlling. The application switches on the proper number and configuration of the keys to get required value of conductance. Keys switching is synchronized with the voltage measurement. It enables to set the intended values of diode current and to measure the DC characteristics. Such an operation allows for switching on short-circuit keys in any configuration for a very short time, which enables measurement for very high diode current values.

In the circuit, the diode current flows through the diode only as short as it is necessary to carry out the measurement and the changing of the temperature of the junction is minimized. The duration of a single measurement pulse is about few milliseconds, while the gap between successive pulses lasts about 1 second. Experimental results showed that for such orders of pulses and gaps durations, the effect of junction heating (i.e. degradation of the shape of IV curve) was not observed.

3. MEASUREMENT RESULTS

Measurements were carried out for eight power SiC diodes type SDT12S60 (cont. forward current $I_F = 12 \text{ A}$, peak reverse voltage $U_R = 600 \text{ V}$) in three different measurement systems:

- system No. 1 – pulse measurement with modified R - $2R$ resistor ladder (proposed method),
- system No. 2 – continuous mode measurements,
- system No. 3 – continuous mode measurements, the diode equipped with radiator.

The representative DC characteristics for one of power SiC diodes measured in three measurement systems are shown in figure 7.

The measurement current range was from 0 A to 12 A with very dense step. In every system the diode case temperature was noted at each measurement point. It was very important because power SiC diode

type STD12S60 works properly for maximum junction temperature equal to 700°C [4].

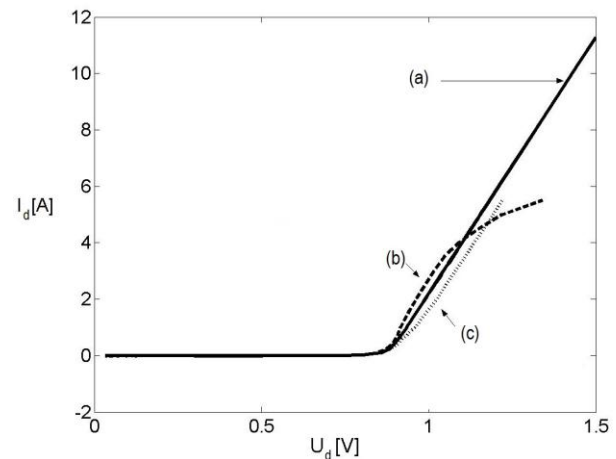

Fig. 7. The DC characteristics for one of SDT12S60 diodes measured in three different systems: (a) – system No. 1, (b) – system No. 2, (c) – system No. 3.

During measurements in system No. 1 the diode case temperature was constant and was equal to 24°C at each point. That is why the measurements were carried out in the assumed current range.

In system No. 2 the measurement were carried out for diode current range from 0.1 A to 5.5 A because the DC characteristic started becoming false at this point. This was caused by the increasing junction temperature – the diode case temperature increased from 27°C (for $I_D = 0.1 \text{ A}$) to 300°C (for $I_D = 5.5 \text{ A}$).

In system No. 3 the measurement were also carried out for diode current range from 0.1 A to 5.5 A. In this case, due to the connected radiator, the diode case temperature increased from 24°C (for $I_D = 0.1 \text{ A}$) to only 32°C (for $I_D = 5.5 \text{ A}$), but still the DC characteristic wasn't alike the one measured in proposed by authors system No. 1.

4. CONCLUSIONS

Authors proposed the simple measurement system (system No. 1) which allows to measure the DC characteristics for very wide current range without causing significant junction temperature increase. As it can be seen in figure 5 the worst results were received in system No. 2. Due to the increasing temperature of the diode, the characteristic became more improper with increasing value of diode current. Measuring DC characteristic with using the radiator gave better results, but not identical with the characteristic measured in system No. 1. Figure 5 shows that only the impulse manner of measurement allows for measuring the isothermal DC characteristic of power SiC diodes.

Using the modified R - $2R$ resistor ladder and short-circuit keys in proposed measurement system allows for very high pulse current measurements. Due to the LabView key controlling application one can switch them on in any configuration for a short time.

The next advantage of the measurement system is its simplicity. Replacing the switching keys by short-circuit keys limits the number of keys needed to carry out the measurement. For N measurement points one needs K keys, where K is the nearest bigger integer value of

$k = \log_2 N$. The example comparison of number of switching and short-circuit keys necessary to the same number of measurement points in the circuits shown in figure 1 and figure 4 is presented in table 1.

Table 1. Comparison of number of switching and short-circuit keys needed for the same number of measurement points.

Number of measurement points	Number of switching keys	Number of short-circuit keys
16	16	4
256	256	8

Moreover, in a typical version of $R-2R$ resistor ladder (fig. 1) each switching key realization needs application of at least two transistors which means the extension of the circuit

5. REFERENCES

1. Cree Technical Data <http://www.cree.com>
2. Infineon Technical Data <http://www.infineon.com>
3. Cichosz J., Szewczyk A. and Stawarz-Graczyk B.: The idea and the system for semiconductor devices DC characteristics measurements, especially for high power semiconductor junctions of electronic devices (in Polish), Biuletyn Urzędu Patentowego, 12/2012, Warszawa, pp. 36-37, ISSN-0137-8015
4. Pyo S., Sheng K.: Junction temperature dynamics of power MOSFET and SiC diode, Proc. Power Electronics and Motion Control Conference, 2009, pp 269-273

METODA I SYSTEM POMIAROWY DO POMIARU CHARAKTERYSTYK STAŁOPRĄDOWYCH DIOD W BARDZO SZEROKIM ZAKRESIE PRĄDÓW

Słowa kluczowe: diody SiC, pomiary, charakterystyka stałoprądowa

Streszczenie: W artykule przedstawiono nowy układ pomiarowy do pomiarów stałoprądowych charakterystyk diod. Autorzy zaproponowali układ do pomiarów impulsowych w celu zachowania niezależności wyników od zmian temperatury diody. Do wytworzenia odpowiednio dużej liczby punktów pomiarowych wartości prądu wykorzystano układ zmodyfikowanej drabinki $R-2R$ z pojedynczymi kluczami sterującymi. Do sterowania system pomiarowym wykorzystano specjalnie opracowaną aplikację w środowisku LabView.