

## MODELLING OF CUTTING BY MEANS OF FRACTURE MECHANICS

**Lubomir JAVOREK**

Assoc.prof. – Technical University in Zvolen – Faculty of Environmental and Manufacturing Technology  
Address: T. G. Masaryka 24, 960 53 Zvolen, Slovak rep.  
E-mail: [lubomir.javorek@tuzvo.sk](mailto:lubomir.javorek@tuzvo.sk)

**Kazimierz ORLOWSKI**

Prof.D.Sc. – Gdansk University of Technology – Faculty of Mechanical Engineering  
Address: Narutowicza 11/12, 80-852 Gdańsk, Poland  
E-mail: [korlowski@pg.gda.pl](mailto:korlowski@pg.gda.pl)

**Jaroslav LALIK**

MSc. – Technical University in Zvolen – Faculty of Environmental and Manufacturing Technology  
Address: T. G. Masaryka 24, 960 53 Zvolen, Slovak rep.  
E-mail: [jaroslav.lalik@tuzvo.sk](mailto:jaroslav.lalik@tuzvo.sk)

**Daniel CHUCHALA**

MSc. – Gdansk University of Technology – Faculty of Mechanical Engineering  
Address: Narutowicza 11/12, 80-852 Gdańsk, Poland  
E-mail: [daniel.chuchala@gmail.com](mailto:daniel.chuchala@gmail.com)

### **Abstract:**

*The suitability of modern fracture mechanic theory was proved for the estimation of the cutting force and the cutting specific resistance. This paper shows modification of Ernst-Merchant theory and its application for determination some other properties of wood sample. This theory is acceptable for evaluation of shear yield stresses and shear plane angle. Sawing by gang saw machine was used as a process similar to the orthogonal cutting. English oak was used as a machined wood species.*

**Key words:** *cutting power; cutting force; specific cutting resistance; oak (Quercus robur L.); fracture mechanics.*

**MODELLING OF CUTTING BY MEANS OF FRACTURE MECHANICS**

**Introduction**

The cutting process is a process of very intensive plastic deformation in the maximal shear tension plane. Machined material will not be modified if shear plane is not exceeded. The first information about cutting models were published in 1937 (Piispanen 1937) and presented cutting as a movement of elementary particles of chips one on another. In order to model the cutting process, it is sufficient to take into consideration the force  $F_{sh,N}$  between workpiece and chip in a share plane and the force  $R_{\gamma N}$  between the rake tool face and the chip (Asthakov).

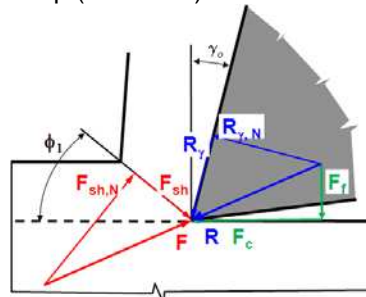

**Fig. 1**  
**Force F and its components (Asthakov).**

After decomposing  $F$  and  $R$  into their components and situating them on the tip of the tool the so-called Merchant circle could be constructed, which represents a fundamental for the theory described below.

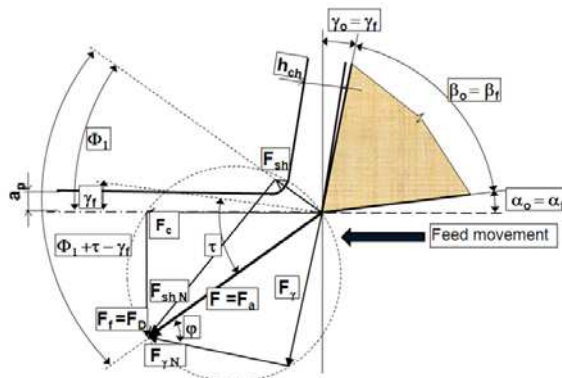

**Fig. 3**  
**Cutting force Merchant's model.**

Having adjusted the model according to the principles of force balance it is possible to specify the friction coefficient between the rake face and the chip by formula (1):

$$\operatorname{tg} \varphi = \mu = \frac{F_{\gamma}}{F_{\gamma N}} = \frac{F_c + F_D \cdot \operatorname{tg} \gamma_0}{F_D - F_c \cdot \operatorname{tg} \gamma_0} \quad (1)$$

The determination of shear strain along the shear plane (i.e. shear deformation) defined by the shear angle  $\phi_1$  allows the formula as follows:

$$\gamma = \frac{\cos \gamma_0}{\sin \phi_1 \cdot \cos(\phi_1 - \gamma_0)} \quad (2)$$

Total energy consumed for cutting per time unit (with regard to plastic deformation only) is:

$$E_c = F_c \cdot v_c \quad (3)$$

Or, specific cutting energy, which is equal to specific cutting resistance (the right side of the equation (i.e. total energy per total volume):

$$e_c = \frac{E_c}{v_c \cdot h_D \cdot b_D} = \frac{F_c}{h_D \cdot b_D} \quad (4)$$

Atkins (2003) established the cutting force equation by considering surface energy as well as plastic deformation work in the primary shear zone and friction work along the tool - chip interface based on Merchant's orthogonal cutting model. In his research, the specific work of new surface formation was regarded as the fracture toughness of the workpiece material. Moreover, in that paper Atkins (2003) proposed to determine a specific cutting resistance as follows:

$$k_c = \frac{1}{Q_{sh}} \cdot \left( \tau_\gamma \cdot \gamma + \frac{R_\perp}{f_z} \right) \quad (5)$$

where:  $Q_{sh}$  is a friction correction factor, which is a function not only friction coefficient  $\mu$  but also rake angle and shear angle  $\Phi_1$ , the latter defines the orientation of the shear plane with respect to cut surface,  $R_\perp$  is fracture toughness (specific work of surface separation/formation) for the cutting speed vector perpendicular to grains,  $\tau_\gamma$  is the shear yield stress,  $\gamma$  is the shear strain along the shear plane, which is given by Eq. (2),  $f_z$  is feed per tooth/uncut chip thickness for sawing processes with linear teeth trajectory (sash gang saw and band saw).

There are several formulas to estimate the angle  $\phi_1$ ; and some of them are presented after Bumbálek (2005) in Table 1.

Even though the cutting model with single shear plane is widely criticised Asthakov (2005), Wang Bing *et al.* (2013), it is still in use by researchers due to its simplicity (Markopoulos 2013). Hence, the most frequent is the formula by Merchant in the form:

$$\phi_1 = 45^\circ - \frac{\varphi}{2} + \frac{\gamma_0}{2} \quad (6)$$

It should be emphasised that this formula is valid for larger values of uncut chip thicknesses (it means in the range where the cutting resistance could has almost constant value). Other authors postulated a little modified formula – some from them mentioned Bumbálek (2005) – see Table 1.

Table 1

**Formulas and authors for computing of angle  $\phi_1$**

Author / year of publishing	Formula for $\phi_1$	Average value
Merchant (1945)	$\phi_1 = 45^\circ - \frac{\varphi}{2} + \frac{\gamma_0}{2}$	24.5°
Time (1870)	$\phi_1 = 90^\circ - \psi_1 + \gamma_0$	29°
Brix (1896)	$\phi_1 = 90^\circ - \eta_1 - \eta_1 + \gamma_0$	34°
Zvorykin – Herman (1893 – 1907)	$\phi_1 = 45^\circ - \frac{\eta}{2} - \frac{\eta_v}{2} + \frac{\gamma_0}{2}$	17°
Ernst – Merchant (1940)	$\phi_1 = 90^\circ - \psi_1 + \gamma_0$	32°
Kristoff – Lee – Shafer (1951)	$\phi_1 = 45^\circ - \varphi + \gamma_0$	19°
Stobler (1951)	$\phi_1 = 45^\circ - \eta + \frac{\gamma_0}{2}$	14°
Hucks (1951)	$\phi_1 = 45^\circ - \frac{\arctg 2\mu}{2} + \gamma_0$	27°
Shaw-Cook- Fienie (1957)	$\phi_1 = 45^\circ - \eta + \gamma_0 + \alpha$	24°
Weiss (1957)	$\phi_1 = 54,7^\circ - \eta + \gamma_0$	28.7°
Zorev (1957)	$\phi_1 = 45^\circ - \frac{\eta + \gamma_0 + \zeta}{2}$	22°

The formula by Atkins (2003) is much more complex, nevertheless, allows to predict shear angles even for small values of uncut thicknesses. However, it can be solved only numerically Orlowski *et al.* (2013).

It should be emphasised that in this approach shear angle is also a function of the uncut chip thickness,  $R_{\perp}$  and  $\tau_{\gamma}$ .

On the basis of Atkins's model (2003), Orłowski and Atkins (2007) proposed a new formula defined for computing the consumption energy during sawing on sash gang saws, which was also useful in case of sawing on circular sawing machines and bandsawing machines (Orłowski *et al.* 2013), as follows:

$$E_{cw} = F_c \cdot v_c + E_{ac} = z_a \left[ \frac{\tau_{\gamma} \cdot s_T \cdot \gamma}{Q_{sh}} \cdot v_c \cdot f_z + \frac{R_{\perp} \cdot s_T}{Q_{sh}} \cdot v_c \right] + E_{ac} \quad (7)$$

where:  $z_a$  is an average number of active teeth being in the contact with the bottom of the kerf. The third component of the eq. might be omitted because its value in the case of sawing on sash gang saw is too small in comparison to other elements. (Orłowski *et al.* (2013)).

$$Q_{sh} = 1 - \left( \frac{\sin \varphi \cdot \sin \phi_1}{\cos(\varphi - \gamma_o) \cdot \cos(\phi_1 - \gamma_o)} \right) \quad (8)$$

Equations (2), (5), (7) and (8) were applied in the further computations of cutting forces and specific cutting resistance.

## MATERIALS AND METHODS

### Specimen preparations

English oak (*Quercus robur* L.) was used for cutting on the sash gang saw. Oak is one of the most important hard wood species in Slovakia (preceded by beech and followed by maple); at present it covers app. 10.7% of the Slovak forest area. Klement *et al.* declares physical properties of the raw material with moisture content 12%. Some from them are shown in the Table 2.

Table 2

**Physical properties of the material**

Density [kg.m <sup>-3</sup> ]		Moisture content of green wood [%]		Fibre-saturation point humidity [%]
in absolute dry status $\rho_0$	reduced in fresh status $\rho_{rc}$	sapwood	adult wood	
390 / 650 / 930	550	70 - 100	60 - 90	32 - 35
Linear shrinkage in direction				Volumetric shrinkage
longitudinal		radial	tangential	
0,4		4,0	7,8	

Because mechanical properties of wood are strongly dependent on its physical properties (i.e. density of wood), which change in the wide range, the best way of determination of needed material values such as fracture toughness and shear yield stresses in the shear plane is cutting experiment Merhar and Bučar (2012), Williams *et al.* (2010). The methodology of those procedures is in details presented in the works Orłowski and Atkins (2007), Orłowski (2009). In computations friction coefficient was equal  $\mu = 0.8$  (Glass and Zelinka 2010).

### Machine, tools and process

All experiments were carried out in the Labs of the Gdansk University of Technology, Dep. of Manufacturing Technology and Automation.

As machine was used the gang saw machine PWR 15 M (Fig. 4), that was designed and made by Wasielewski *et al.* (Wasielewski 1999, Wasielewski and Orłowski 2002). Technical parameters are in Table 4.



**Fig. 4**  
**Sash gang saw PRW 15 M.**

Table 4

**Technical parameters of gang machine**

Stroke of saw blade $H_{pl}$ [m]	0,162
Number of strokes $n$ [ $\text{min}^{-1}$ ]	685
Stroke frequency $n$ [ $\text{s}^{-1}$ ]	11,416
Average cutting speed $v_c$ [ $\text{m}\cdot\text{s}^{-1}$ ]	3,699

As tool was used saw blade presented in Fig. 5 with its parameters in Table 5.

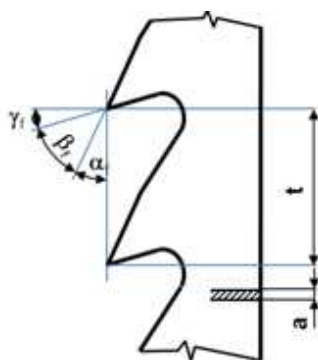

Table 5

**Dimension and geometry of saw blade**

Back (clearance) angle $\alpha_f = \alpha_o$ [ $^\circ$ ]	9.3
Wedge angle $\beta_f = \beta_o$ [ $^\circ$ ]	72.25
Rake angle $\gamma_f = \gamma_o$ [ $^\circ$ ]	8.46
Pitch of saw teeth $t$ [m]	0.013
Kerf $s_T$ [m]	0.002
Thickness of body $a$ [m]	0.0016

**Fig. 5**  
**Saw blade: dimensions and geometry.**

For cutting were used samples of wood with dimensions: 500×75×75mm (Length × Height × Width). Thickness of obtained lamellas was 5mm and simultaneously 5 saw blades were in process.

Feed speed was changed in two levels and it was in range from 0,005mpm to 0,008mpm, and from 0,017mpm to 0,021mpm.

The data was picked up by a simple acquisition software SPEKTRA (Listing of Spektra softver see Fig. 6) from power transducer, via the USB micro-DAQ converter with a sampling frequency of 40Hz, in format \*.dat, where output was total cutting power and that to further processing in the MS Excell software (Fig. 7).

```

Program SPECTRA
4D05 (Code of file)
4095 (Number of values) 0.0250000 (time between records) 1.744380
1.727900
1.724604
1.723945
1.730342
1.738886
...
    
```

**Fig. 6**  
**Listing of data by Spektra software.**

**Analyses and conclusion**

During the cutting process of all samples, the feed speed was changed in two levels. Records of consumed energy as well as sawn surfaces are displayed in Fig. 7.

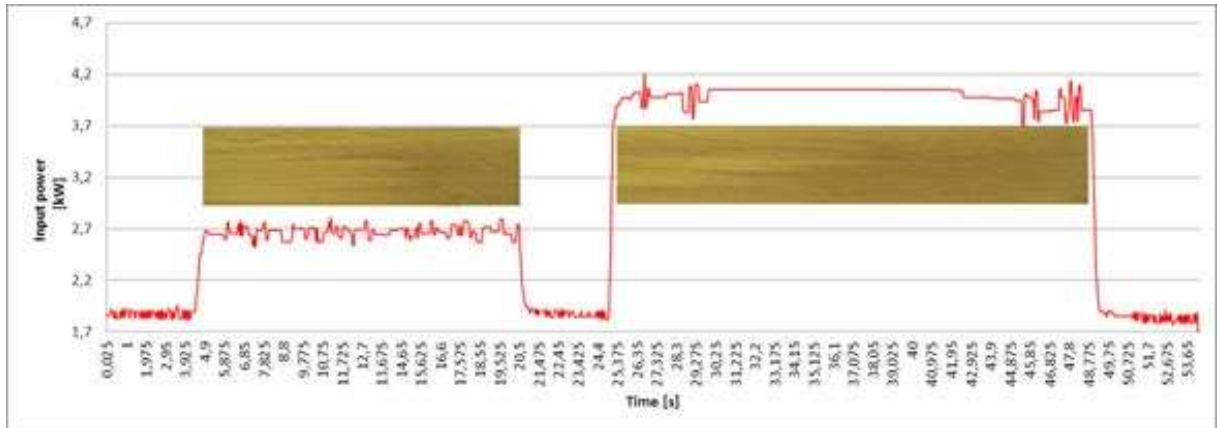

**Fig. 7**  
**Recorded course of cutting power at two levels of feed speed during sawing.**

All values were transferred from analogue to digital form and prepared by MS Office/MS Excell. Results are displayed in and Fig. 8.

Graph in Fig. 7 reflects predictions of cutting force obtained with the use of cutting models that accept energy (work) for separation and in conjunction with plasticity and friction, chip acceleration's power during cutting on gang saw (like simulation of orthogonal cutting).

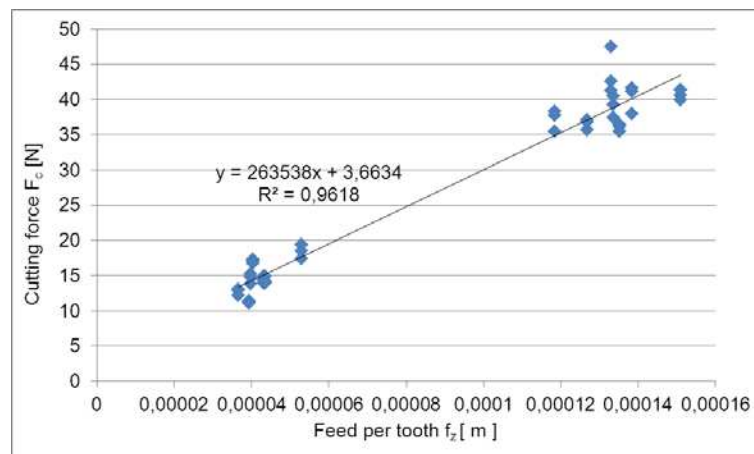

**Fig. 8**  
**Experimental values of cutting force in a function of feed per tooth (uncut chip thickness).**

The graph in Fig. 9 shows the dependence of specific cutting resistance obtained during the same machining. It shows a very high gradient for small feed per tooth, or for small chip thickness; it underlines the importance of technological parameters and their relation for acceptable cutting process. That phenomenon is called a size effect (Atkins 2003, 2009).

From formula (7) by combination with formula of line from Fig. 8 results:

$$3,6634 = \frac{R_{\perp} \cdot s_T}{Q_{sh}} \quad (9)$$

If to this formula  $Q_{sh}$  will be substituted with computing results ( $=0.613$ ) from formula (8) with acceptance of angle  $\gamma$  from formula (2) we obtain  $R_{\perp}=1814\text{Jm}^{-2}$ . This value represents fracture toughness, i.e. parameter joins with machined material.

The curved line in Fig. 9 shows the extreme increase of specific cutting resistance for very small chip thickness.



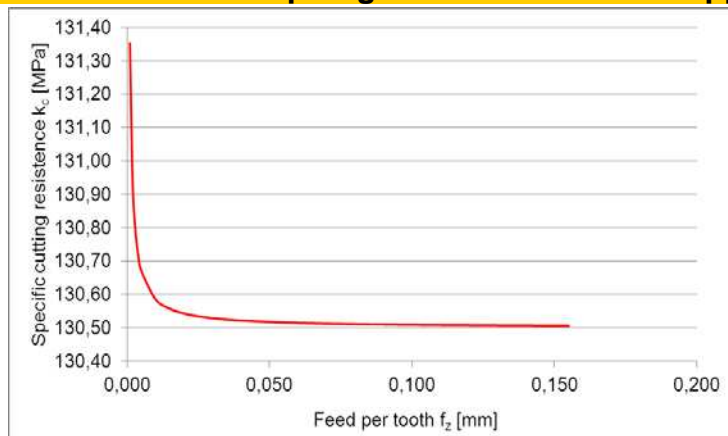

Fig. 9

**Predicted cutting resistance vs. feed per tooth (uncut chip thickness) during sawing of oak wood on the sash gang saw PRW15M.**

Results mentioned above illustrate the possibility to determinate the toughness and shear yield strength during a cutting similar to orthogonal wood cutting. Used technology of sawing was one of available technologies with quasi transversal model of cutting and quasi orthogonal cutting. It shows, that exists a possibility to calculate other parameters of wood directly from machining.

The presumption of applying the theory was proven as quite real.

## CONCLUSION

In the beginning of experiment was expectation, whether exists possibility to evaluate material properties from parameters joined with cutting process, i.e. to eliminate or recompense tests of made raw products. This experiment shows, that this possibility, seems, exist.

## REFERENCES

- Asthakov V (2005) On the inadequacy of the single-shear plane model of chip formation. In: Int. J. of Mechanical Sciences 47:1649–1672
- Atkins AG (2003) Modelling metal cutting using modern ductile fracture mechanics: quantitative explanations for some longstanding problems. In Int. J. of Mechanical Sciences 45:373–396
- Atkins AG (2009) The science and engineering of cutting. The mechanics and process of separating, scratching and puncturing biomaterials, metals and non-metals. Butterworth-Heinemann is an imprint of Elsevier, Oxford
- Bumbálek B (2005) Fyzikální podstata řezání. (The physical basic of cutting). Ústav strojírenské technologie. (Institute of technology engineering) Vysoké učení technické v Brně. (Brno University of Technology). Fakulta strojního inženýrství. (Faculty of Mechanical Engineering). Pp. 125 (P.46, tab. 5,2)
- Glass SV, Zelinka SL (2010) Moisture relations and physical properties of wood (Chapter 4). In: Wood Handbook – Wood as an Engineering Material (Centennial Edition). General Technical Report FPL-GTR-190. Madison, WI: U.S. Department of Agriculture, Forest Service, Forest Products Laboratory. Pp. 508 [http://www.fpl.fs.fed.us/documnts/fplgtr/fpl\\_gtr190.pdf](http://www.fpl.fs.fed.us/documnts/fplgtr/fpl_gtr190.pdf) (access in May 2013)
- Klement I, Réh R, Dettvaj J (2011) Dub letný. In: Základné charakteristiky lesných drevín – spracovanie drevnej suroviny v odvetví spracovania dreva. Národné Lesnícke Centrum, pp. 82 ISBN 978-80-8093-112-4. <http://www.nlcsk.sk/files/1708.pdf>. (access in June, 2013)
- Merchant ME (1945) Basics mechanics of metal cutting process. Trans. ASME Journal of Applied mechanics Phys., 16:267–318
- Merhar M, Bučar B (2012) Cutting force variability as a consequence of exchangeable cleavage fracture and compressive breakdown of wood tissue. Wood Sci Technol 46(5):965–977
- Orlowski KA, Atkins A (2007) Determination of the cutting power of the sawing process using both preliminary sawing data and modern fracture mechanics. pp. 171–174. In: Navi, P., Guidoum, A. (Eds.) Proc. of the Third Inter. Symposium on Wood Machining. Fracture Mechanics and Micromechanics of Wood and Wood Composites with regard to Wood Machining., 21–23 May, Lausanne, Switzerland. Presses



Polytechniques et Universitaires Romandes, Lausanne. ISBN 978-2-88074-725-1

Orlowski K (2010) The fundamentals of narrow-kerf sawing: the mechanics and quality of cutting. Technical University in Zvolen. Pp. 150. ISBN 978-80-228-2140-7

Orlowski K A, Ochrymiuk T, Atkins A, Chuchala D (2013) Application of fracture mechanics for energetic effects predictions while wood sawing. Wood Sci Technol DOI 10.1007/s00226-013-0551-x (Open access)

Wang Bing, Liu Zhanqiang, Yang Qibiao (2013) Investigations of yield stress, fracture toughness, and energy distribution in high speed orthogonal cutting, International Journal of Machine Tools & Manufacture, <http://dx.doi.org/10.1016/j.ijmachtools.2013.05.007>

Wasielewski R (1999) Pilarki ramowe z eliptyczna trajektoria prowadzenia pil i hybridowym wyrownowazonym dynamicznie ukladem napendu glównego. (Frame sawing machines with an elliptical trajectory of saw blades guiding and the hybrid dynamically balanced main drive system). ISBN 83-88007-28-9

Wasielewski R, Orlowski K (2002) Hybrid dynamically balanced saw frame drive. Holz Roh- Werkst 60:202-206

Williams JG, Patel Y, Blackman BRK (2010) A fracture mechanics analysis of cutting and machining. Eng Fract Mech 77(2):293-308