

## SIMPLIFIED DYNAMIC MODEL OF ROTATING BEAM

Rafał HEIN, Cezary ORLIKOWSKI

Faculty of Mechanical Engineering,  
Department of Mechanics and Mechatronics  
Gdansk University of Technology,  
Narutowicza Street 11/12, 80-233 Gdansk  
fax: (+48) 58 347 21 51, email: [rahe@pg.gda.pl](mailto:rahe@pg.gda.pl)

### Summary

In the paper a hybrid model of rotating beam is presented. It was obtained by using two methods: modal decomposition and spatial discretization. Reduced modal model was built for the system without the load related to inertia forces that occur during beam rotation. This inertia load was next modeled by using the method of simply spatial discretization and combined with reduced modal model. This approach allows to obtain accurate low-order model of rotating beam.

Keywords: mechanical system, modelling, vibration, modal analysis, model reduction.

### UPROSZCZONY MODEL DYNAMICZNY WIRUJĄCEJ BELKI

#### Streszczenie

W artykule przedstawiono hybrydowy model wirującej belki. Otrzymano go stosując dwie metody: dekompozycji modalnej oraz dyskretyzacji przestrzennej. Zredukowany model modalny zbudowano dla układu bez obciążenia wynikającego z działania sił bezwładności występujących podczas ruchu belki. Oddziaływanie to uwzględniono stosując metodę dyskretyzacji przestrzennej. Takie podejście umożliwia otrzymanie dokładnego modelu niskiego rzędu wirującej belki.

Słowa kluczowe: układy mechaniczne, modelowanie, drgania, analiza modalna, redukcja modeli.

### [1] INTRODUCTION

Rotating flexible structure can be considered as a physical model of elastic linkage, manipulator arms, helicopter rotor and others. Such structures are distributed or distributed-lumped parameter systems. An rotating Euler-Bernoulli or Timoshenko beam was studied by many authors [1-5,8,9,16-22].

By application of finite element method (FEM) it is possible to obtain adequate accurate mathematical model. However FEM models are usually high order ones. In some applications for example in automatic control systems design procedures, low order models are preferred.

Designers greatly benefit from the availability of very small models that capture the behaviour of a complex system with almost the same accuracy as a high order model. A simple but adequate model of a system reflects the basic properties and provides good inside into the process.

The purpose of the paper is to build the model of a beam vibrating in horizontal plane. Two methods of modelling has been applied – modal decomposition and spatial discretization. Modal model of Euler-Bernoulli beam can be constructed in very simply way by application of known eigenvalues and eigenfunctions. The distributed inertia forces were

modelled by application of simple lumping technique. Hence, finally obtained model is hybrid one.

General idea of the proposed modelling has been presented in [10]. In the method a reduced modal model is built for a part of considered system excluding elements and phenomena that make difficulties in modal decomposition and analysis. These phenomena are next modelled by application of spatial discretization method. In this way one obtains two submodels which are next combined with one another into the hybrid model. The methodology was successfully applied by authors for many different dynamic systems analysis [10-14].

This paper describe the first attempt of hybrid modelling application for rotating beam.

Fig. 1 presents considered Euler-Bernoulli beam. External moment causes body rotation and small elastic deformation.

For the considered system following equation of motion can be derived [21]

$$(I_H + I_B)\ddot{\phi} + \rho A \int_r^{r+l} xy_u dx = M \quad (1)$$

$$\rho y_{tt} + EI y_{xxxx} = \dot{\varphi}^2 y_{xx} \rho A \int_x^{r+l} \xi d\xi - \ddot{\varphi} \rho A x + \quad (2)$$

$$-\dot{\varphi}^2 (xy_x - y) \rho A$$

where

$$I_B = \rho A \int_r^{r+l} x^2 dx$$

is the moment of inertia of the

undeformed beam and:  
 $M$  – external moment,  $\varphi$  – rigid body rotation,  $r$  – hub radius,  $l$  – length of beam,  $I_H$  – hub moment of inertia,  $EI$  – flexural rigidity,  $y$  – transverse displacement of the beam,  $\rho$  – density,  $A$  – cross section area.

The boundary conditions are:

$$y(x, t)|_{x=r} = 0, \quad y_x(x, t)|_{x=r} = 0,$$

$$EI y_{xx}(x, t)|_{x=r+l} = 0$$

$$EI y_{xxx}(x, t)|_{x=r+l} = 0$$

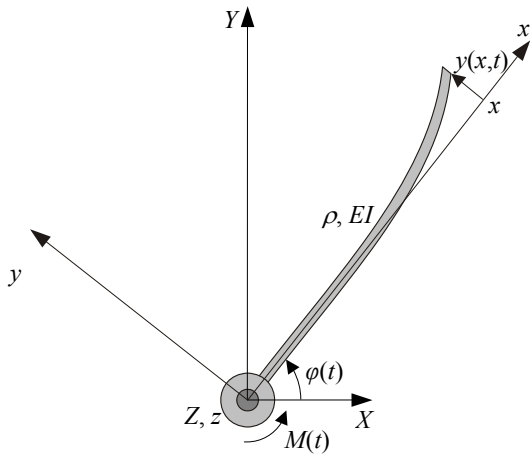

Fig. 1. Euler-Bernoulli beam rotating in horizontal XY plane

In the case of sufficiently small angular speed one can reduce equations (2) to the linear form and finally we have:

$$(I_H + I_B) \ddot{\varphi} + \rho A \int_r^{r+l} xy_{tt} dx = M \quad (3)$$

$$\rho A y_{tt} + EI y_{xxxx} = -\ddot{\varphi} \rho A x \quad (4)$$

Considering beam rotating in vertical plane it is necessary to take into account distributed gravity force which causes a distributed moment dependent on the angular position of rotating beam and transverse distributed load - Fig. 2.

In such case the set of equation describing rotating beam are following

$$(I_H + I_B) \ddot{\varphi} + \rho A \int_r^{r+l} xz_{tt} dx + \rho A g \int_r^{r+l} \cos(\varphi + z_x) x dx = M \quad (5)$$

$$\rho A z_{tt} + EI z_{xxxx} = -\ddot{\varphi} \rho A x - \rho A g \cos(\varphi + z_x), \quad (6)$$

with boundary conditions:

$$z(x, t)|_{x=r} = 0, \quad z_x(x, t)|_{x=r} = 0,$$

$$EI z_{xx}(x, t)|_{x=r+l} = 0$$

$$EI z_{xxx}(x, t)|_{x=r+l} = 0$$

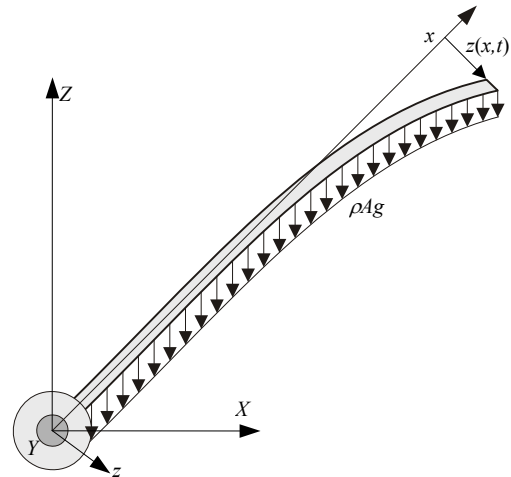

Fig. 2. Beam rotating in vertical ZX plane

Very interesting situation from modelling point of view appears when we assume that a flexible link performs motion in the horizontal and the vertical planes. Let us consider situation when driving rigid hub rotates around vertical axis - Fig. 3.

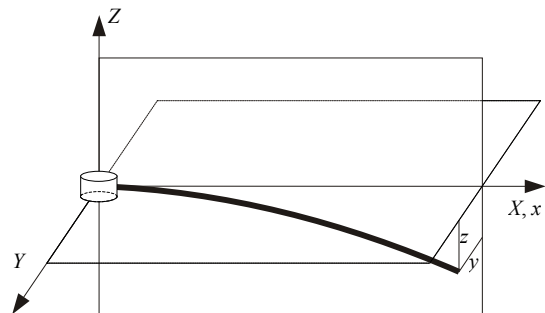

Fig. 3. Beam rotating in horizontal plane YX and transverse displacements in two perpendicular planes YX, ZX

In such case elastic deformations in the horizontal plane are excited by external moment and in the vertical plane are caused by weight of the beam which acts as a distributed force. Such loads cause that combined transverse and torsional vibration appear. Equation describing such system are following [16]:

in the horizontal plane

$$\rho A y_{tt} + EI y_{xxxx} = -\ddot{\varphi} \rho A x \quad (7)$$

and in the vertical plane

$$\rho A z_{tt} + EI z_{xxxx} = -\rho A g \cos z_x. \quad (8)$$



Obtained reduced model of beam can be directly coupled with the discrete model of distributed load (11, 12). Graphical form of the final hybrid reduced model is presented in Fig. 5.

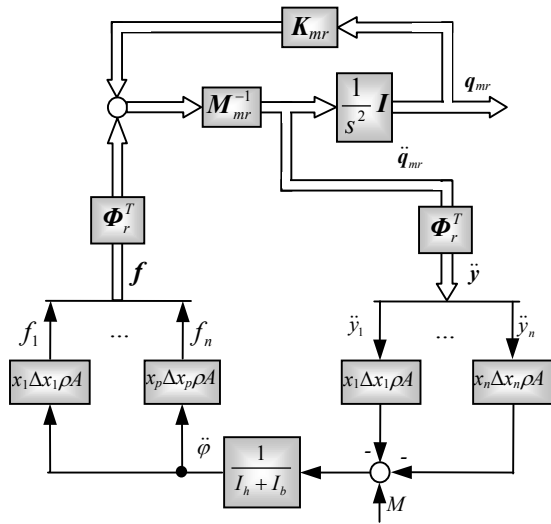

Fig. 5. Graphical representation of hybrid model described by (12,13,16)

Grace to diagonalization it is possible to present the modal model in the detailed form – Fig. 6. It must be mentioned that two submodels reduced modal model of beam and model of inertia load are coupled in  $n$  power ports. The pair of signals  $(f_i, y_i)$  are related to the  $i$ -th port. The order of the whole model depends on the number of retained modes in the modal model but it does not depend on the number of ports. It means that inertia loading can be modelled by using any number of finite elements.

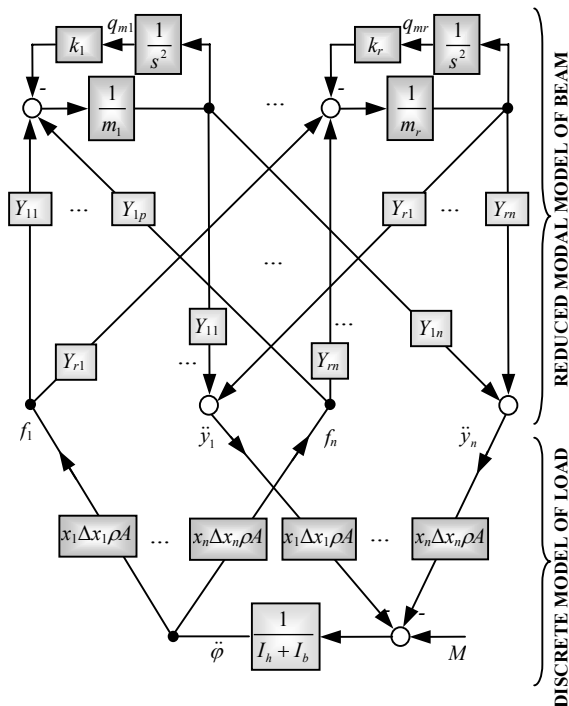

Fig. 6. Hybrid reduced model

### 3. Simulation and results

Simulations were performed using the Matlab-Simulink package applying the following physical data: Young modulus of elasticity  $E=69 \cdot 10^9$  [Pa], mass density  $\rho=2700$  [kg/m<sup>3</sup>], length of beam  $l=0.62$  [m], hube radius  $r= 0.03$ [m], cross section dimensions:  $h=0.002$  (height),  $b=0.015$  (width).

Fig. 4 and Fig. 5 (or 6) present complete mathematical models in the form accepted by mentioned software tool. Model from Fig. 4 was considered as reference (full) model of the given system. Fig. 7 presents frequency response related to not rotating beam (without inertia load) – dotted line, and modal reduced model of the beam – continuous line. Reduced model has 3 retained modes.

Frequency characteristics obtained for the reference model and hybrid reduced model (both of them related to the rotating beam) are presented in Fig. 8. The frequency characteristics of the full (reference) model of the investigated system is presented by dotted line. It is compared to the characteristic related to the proposed hybrid model – continuous line. Obtained results prove that proposed method enables to obtain accurate low order model in the frequency range related to the number of retained modes.

Presented frequency characteristics (Fig. 7-8) were obtained for the moment  $M$  as the input signal and the beam displacement at its free end.

Fig. 9b presents time response of the system. The output signal  $u=\phi l + y(l+r)$  (Fig. 9c) was obtained for the input signal  $M$  in the form presented in Fig. 9a.

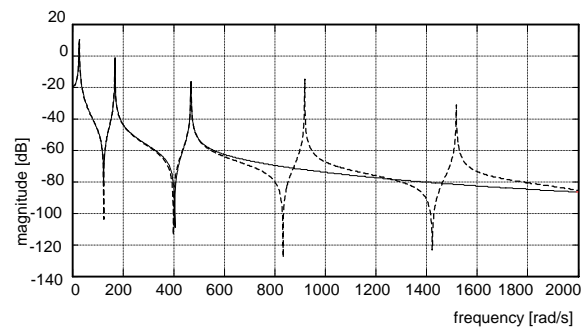

Fig. 7. Comparison of frequency characteristics of full (reference) model and modal reduced model

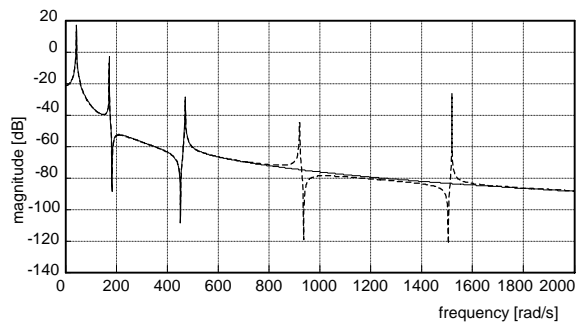

Fig. 8. Frequency response of the whole system

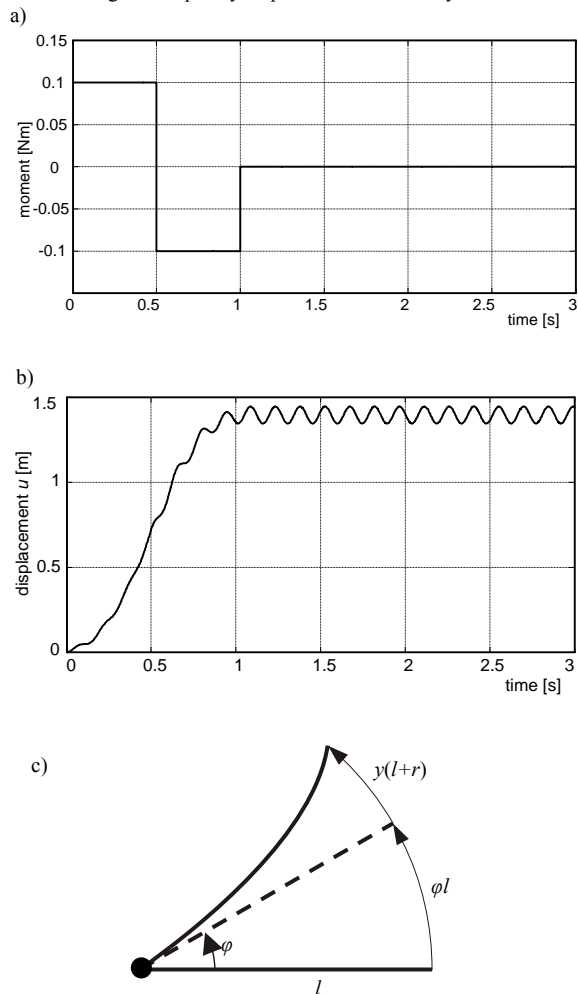

Fig. 9. Time response of the hybrid, reduced model

#### 4. Conclusion

A hybrid modelling procedure for analysis the dynamics features of rotating beam is proposed in the paper. Two modelling techniques are used: modal decomposition and spatial discretization. The final reduced (low order) model is obtained in the following way. First, the finite element method (spatial discretization) is applied to obtain lumped parameter model of the whole investigated system. Next, modal decomposition and reduction is applied for model of beam without inertia load which results from beam rotation. Finally reduced modal model of beam is combined with the model of inertia load. Some simulation results presented in the paper

provide that presented method of modelling is efficient and enables obtain low order model with assumed accuracy.

The presented method of modelling is the first step of application the proposed method to modelling rotating beam.

Further works will be related to the beam rotating in a vertical plane and next to the beam moving in both horizontal and vertical planes.

The last case is very interesting because a torsional vibrations appear as the effect of coupling bending vibrations in two perpendicular planes.

Proposed methodology of hybrid modelling enables to include effects of linear or nonlinear coupling between submodels.

#### REFERENCES

- [2] Al-Said, S., Naji, M., and Al-Shukry, A.: *Flexural Vibration of Rotating Cracked Timoshenko Beam*, J. Vib. Control, Vol. 12, pp. 1271–1287, 2006
- [3] Ansari M., Esmailzadeh, Jalili N.: *Exact frequency analysis of a rotating cantilever beam with tip mass subjected to torsional-bending vibrations*, Journal of Vibration and Acoustics, Vol. 133, 2011
- [4] Barbosa E.G., Gões L.C.S.: *Modeling and identification of flexible structure using bond graphs applied on flexcam quanser system*, ABCM Symposium Series in Mechatronics, Vol. 3, pp. 129-138, 2008
- [5] Bercin, A.N., Tanaka, M.: *Coupled Flexural-Torsional Vibrations of Timoshenko Beams*, J. Sound Vib., Vol. 207, pp. 47–59, 1997
- [6] Furta, S. D.: *Linear Vibrations of a Rotating Elastic Beam With an Attached Point Mass*, J. Eng. Math., Vol. 46, pp. 165–188, 2003
- [7] Gawroński W., Kruszewski J., Ostachowicz W., Tarnowski J., Wittbrodt E.: *The finite element method in the dynamics of structures* [in Polish], Arkady, Warsaw 1984
- [8] Kruszewski J., Gawroński W., Wittbrodt E., Najbar F., Grabowski S.: *The rigid finite element method* [in Polish], Arkady, Warsaw 1975
- [9] Lin S. M.: *Dynamic Analysis of Rotating Nonuniform Timoshenko Beams with an Elastically Restrained Root*, Journal of Applied Mechanics, Vol. 66, pp. 742-749, 1999
- [10] Lin, S., Mao, I., and Lin, J., 2007, *Vibration of a Rotating Smart Beam*, AIAA J., 45, pp. 382–389
- [11] Orlikowski C.: *Modelling, analysis and synthesis of dynamic systems by application of bond graphs*. Gdańsk University of Technology Press, Gdańsk, 2005 [in Polish]
- [12] Orlikowski C., Hein R.: *Modal reduction and analysis of gyroscopic systems*. Solid State Phenomena 164 (2010) 189-194.
- [13] Orlikowski C., Hein R.: *Reduced model of gyroscopic system, Selected Problems of Modal Analysis of Mechanical Systems*, Editor T. Uhl,

- Radom: Publishing House of the Institute for Sustainable Technologies National Research Institute, 2009, AGH, Kraków 2007,
- [14] Orlikowski C., Hein R.: *Modelling and analysis of rotor with magnetic bearing system, Developments in mechanical engineering*, Editor J. T. Cieśliński, GUTP, Gdansk 2008,
- [15] Orlikowski C., Hein R.: *Hybrid, approximate models of distributed-parameter systems*. The 12th Mechatronics Forum Biennial International Conference. Part 2/2, Zurich, June 28-30, 2010 / H. Wild, K. Wegner. - Swiss Federal Institute of Technology, p. 163-170, 2010
- [16] Rao S. S.: *The finite element method in engineering*, IV ed., Elsevier, 2005
- [17] Sutton R.P., Halikias G.D., Plummer A.R., Wilson D.A.: *Modelling and  $H^\infty$  control of a single-link flexible manipulator*, Proc Instn Mech Engrs, Vol. 213, Part I, pp. 85-104, 1999
- [18] Turhan Ö., Bulut G.: *On Nonlinear Vibrations of a Rotating Beam*, J. Sound Vib., Vol. 322, pp. 314–335, 2009
- [19] Yardimoglu B.: *Vibration Analysis of Rotating Tapered Timoshenko Beams by a New Finite Element Model*, Shock Vib., Vol. 13, pp. 117–126, 2006
- [20] Yigit A., Scott R.A., Ulsoy A.G.: *Flexural motion of a radially rotating beam attached to a rigid body*, Journal of Sound and Vibration, Vol. 121, No. 2, pp. 201-210
- [21] Yuksel S., and Aksoy T. M.: *Flexural Vibrations of a Rotating Beam Subjected to Different Base Excitations*, Gazi University Journal of Science, Vol. 22, pp. 33–40, 2009
- [22] Zhu W.D., Mote C.D.: *Dynamic modeling and optimal control of rotating Euler-Bernoulli beams*, Journal of Dynamic Systems, Measurement and Control, Vol. 119, pp. 802-808, 1997
- [23] Zhu W.D.: *Dynamical analysis and optimal control of a flexible robot arms*, M.Sc. Thesis, Arizona State University, Tempe, AZ, 1988

*The research is supported from the science budget resources in 2011-2014 as the research project (N N501 120240)*



**Rafal HEIN**, D.Sc. Eng. is an assistant professor at the Faculty of Mechanical Engineering, Gdańsk University of Technology. His research interests focus on the modelling of dynamic mechanical and mechatronic systems



**Cezary ORLIKOWSKI**, D.Sc. Ph.D. Eng. is an assistant professor at the Faculty of Ocean Engineering and Ship Technology, Gdańsk University of Technology. In addition, he is also working as professor and he is a Deputy Rector in The State School of Higher Professional Education in Elbląg. His current research interest include mechatronics and dynamic systems modelling.

