

PROJECT OF AN TDC SIGNAL DISTRIBUTOR PROTOTYPE WITH GALVANIC SEPARATION DESTINED FOR STUDIES OF THE BEGINNING OF SELFIGNITION USING LANGMUIR PROBE

Jacek Rudnicki

*Gdańsk University of Technology
Faculty of Ocean Engineering and Ship Technology
Department of Marine and Land Power Plants
80-951 Gdańsk, ul. G. Narutowicza 11/12
e-mail: jacekrud@pg.gda.pl*

Leszek Piechowski

*The Szewalski
Institute of Fluid-Flow Machinery
Polish Academy of Sciences
80-231 Gdańsk ul. Fiszera 14*

Abstract

The knowledge of pistons' TDC is crucial while performing any kind of measurement beneficial to diagnostic inference of a diesel engine. The research of engines under exploitation often cause impartial difficulties with, eg. capability of probe installation. Therefore, it becomes crucial to minimize those. The paper presents a description of a TDC impulse distributor - divider that provides signal delivery to more than one measurement system used during the research (here - cylinder indication system and Langmuir probe system). The necessity of galvanic separation of signals was justified and detailed, electronic schematic diagrams of two solutions of TDC signals distributors were presented. Those are systems with two and four independent output. The distributor's system with two outputs was realized in practice as a prototype used during measurements performed on diesel engines. Alternative possibilities of manufacturing any kind of distributor, according to user's needs, were presented.

Key words: diesel engine, top dead center, Langmuir probe

1. Introduction

Knowing the piston's position in TDC point (Top Dead Point) is crucial to determine the correct performance of a diesel or petrol engine. TDC is used as eg. a reference point (Fig. 1) during measurements of parameters listed below [1,4]:

- a) pressure change course (using electronic pressure meter),
- b) point when vibrations appear in engine structure (using vibration meter),
- c) crankshaft's rotation period (rotation velocity measurement)
- d) selfignition angle,
- e) other courses available to imagine using an oscilloscope, eg. electrical pulses received from Langmuir's probe)

A relevant limitation during simultaneous measuring of these parameters is that, when only one source of TDC impulse distribution is used, it is necessary to connect one of measuring tip of every system mutually. It is a reference point common for all measuring systems. This common measure point is marked as **GND** and is called a **measurement mass**. The common connection of one measuring tip (to GND point) is a relevant limitation during measurements, as additional interfering signals

are brought in. These interfering signals are formed as a result of existing current flows during potentials leveling between measuring tips of individual measurement systems.

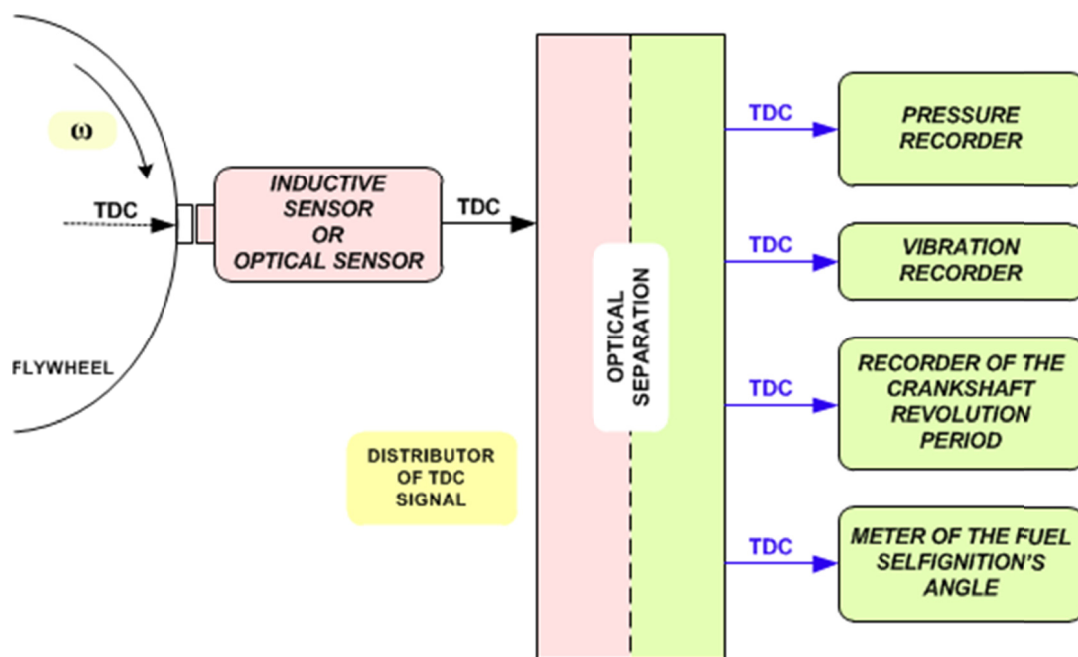

Fig.1 Measurement systems that collect TDC impulse

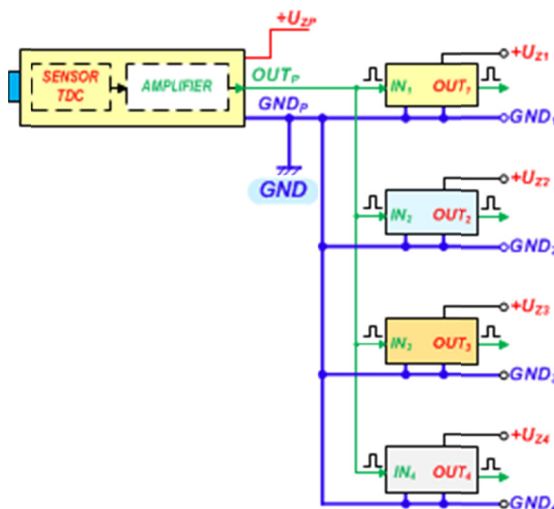

Fig.2 Schematic diagram of TDC impulse distributor without galvanic separation, with common GND point.

2. Galvanic separation of measurement systems

Measurement systems that create individual channels, mentioned previously as 1 a - e, are most commonly reinforced by separate sources. The perfect solution (that brings no additional disruptions) is transfer of TDC signal to separate measurement systems without connection to the mutual GND point. The measurement limitation can be removed when galvanic isolation (separation) in TDC signal transfer to each measurement system alone is used.

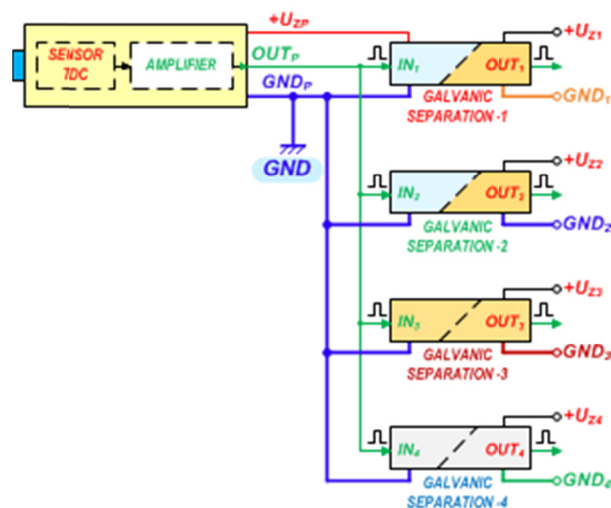

Fig.3 Diagram scheme of a TDC signal distributor with galvanic separation

Fig.3 represents such measurement situation. In such system the TDC signals (directed to different measurement systems) have separate, not connected to each other outputs $GND_1 \div GND_4$.

In Fig. 7 application of this solution in a TDC impulse distributor project is presented. Galvanic separation can be created in a number of ways:

- a) In practice a solution when signal is relayed through separation converter (magnetic separation) is used. This method has its limitations related to separation converter usage and its control.
- b) by using optical signal transfer circuits.

In practice, a TDC signal is binary logic signal (the so-called digital). The variety of electronic components based on digital signal relay allows to design various constructions.

3. Sensors detecting a TDC point location

There are a few types of location sensors that can be used. In practice the most used types of sensors - TDC detectors are as follows: [3,4]:

- a) sensors reacting to metal presence before the sensor's head
A representative of this group is a sensor that works based on a rule of muting the built-in electronic generator's vibrations. The vibrations are muted as metal before the sensor's head appears,
- b) a sensor which uses the Hall effect where magnetic flow is changed as a result of ferromagnetic metal influence,
- c) eddy-current sensors that use the effect of eddy currents in the metal base

Each of these types of sensors has a built-in comparator that change the value of the measurement signal to a binary logic signal. The comparator has a set value of a reference level of the measurement signal. If the value of the signal is below the comparator's reference value, the logical signal at the sensor's output has a logical value of "0" (false). If the value of the signal is over the comparator's reference value, the logical signal at the sensor's output has a logical value of "1" (true).

a) sensors reacting to a change of value of a reflected optical signal

The principle of operation of this sensor is sending an optical signal towards the surface that reflect the light beam. The source of light is usually a light-emitting diode. The surface has a separated area that either reflects (or absorbs) the light beam. The reflected beam is detected by the light radiation detector. The detector is usually a photodiode or a phototransistor. The reflected signal is amplified to the value allowing the proper work of the sensor. As in the magnetic sensors, the sensor has a built-in comparator, that alters the measured signal to a binary logic signal.

b) sensors reacting to discontinuity of optical signal

In this technological solution of the sensor, the light-emitting diode transfers the optical signal directly to the light detector. This principle is used in angle - pulse converters. The converters of this type convert the angle position of converter's shaft to a certain number of impulses (eg. 3600 impulses).

es/1 full rotation). Modern converters have one extra output that sends a single impulse per one full rotation of the crankshaft. The duration of the impulse is, for the presented example, $1/3600$ of T duration of the crankshaft rotation.

4. The prototype of the TDC signal distributor of the diesel engine with galvanic separation.

In Fig. 8 a scheme diagram of the TDC impulse distributor was presented, it is a scheme diagram of a distribution system performed as a prototype. In the TDC impulse distribution system, the elements of combustion pressure analyzer's construction produced by LEMAG [5] were used. The analyzer has in its construction a built-in inductive sensor. The inductive sensor is powered by combustion pressure analyzer's AC. Due to inductive sensor's connection to analyzer with a 3-wire connection (using a socket), there is a possibility of access to signals occurring on single wires of the connection. A proper signal adapter as created for this purpose. The combustion pressure analyzer has three wires marked respectively:

- a) $+U_z=8V$,
- b) GND,
- c) SGN – a signal changing level H to L, when the inductive sensor detects a metal element.

To the wire of + 8V voltage, a stabilizer of + 5V was attached, which supplies integrated circuits U1 and U2 that form the signal transferred to the optocoupler TN1 and TN2 (optical isolation). The power supply of + 8V is so high that there is no problem with the control optocouplers.

Distributor's system has two in-built separation transformers (DC/DC) +12V/+12V.

Primary side of these transformers is powered by an additional power supply with +12V voltage. An additional power source, such as power supply (+12V) or a VRLA battery +12V, can be used. Additional voltage of +12V is supplied to the distributor's system through a power plug.

4.1 Signal forming circuit VIBRATIONS

This circuit has a separated signal mass *GDN - E*.

The signal forming circuit includes:

- transformer DC/DC, 12V/12V,
- +8V and +5V voltage stabilizers, while +8V voltage stabilizer is used to supply power to the impulse signal output with 0÷ +8V voltage. The +5V stabilizer supplies power to digital integrated circuits,
- TN1 optocoupler, which transistor directs the U3, U4 and U5 digital systems,
- U4 digital system (74LS06) allow to create a TDC signal of +8V voltage,
- U5 digital system (74HCT541) allow to create a TDC signal of +5V voltage,
- to the adequate pins of DB9-F (having pin number given) all TDC signals were input. Fig.8 presents these signals' distribution by connector described as VIBRATIONS.

TDC output signals with +8V and +5V also have a different direction of signal's level change. Signals marked as \perp (positive), change their level from 0V to +5V or +8V. Signals marked as \top (negative), change their level from +5V or +8V to 0V.

A pulsing green LED signal diode informs of presence of +8V TDC signal. A pulsing red LED signal diode informs of presence of +5V TDC signal.

4.2 Signal forming circuit OSCILLOSCOPE

This circuit has a separated signal mass *GDN - I*.

The signal forming circuit includes:

- transformer DC/DC, 12V/12V,
- +8V and +5V voltage stabilizers, while +8V voltage stabilizer is used to initial voltage reduction of +5V stabilizer. The +5V stabilizer supplies power to digital integrated circuits,
- TN2 optocoupler, which transistor directs the U6, and U7,
- U7 digital system (74HCT541) allow to create a TDC signal of +5V voltage,

- to the adequate pins of DB9-F (having pin number given) all TDC signals were input. Fig.8 presents these signals' distribution by connector described as OSCILLOSCOPE.

TDC output signals with +5V also have a different direction of signal's level change. Signals marked as \perp (positive), change their level from 0V to +5V. Signals marked as \top (negative), change their level from +5V to 0V.

A pulsing red LED signal diode informs of presence of +5V TDC signal.

5. The project of the TDC signal distributor of the diesel engine with four galvanic separated outputs,

In Fig. 9 a different idea of another project's version of the TDC signal distributor of the diesel engine with four galvanic separated signal grounds and having +5V amplitude outputs was presented. In this project an extended range of additional supply of voltage to DC/DC transformers was used. The supply of voltage may vary between +8V÷+35V. This range of the supply of voltage allow to supply the TDC signal distributor both with +12V and +24V voltage. Such universality of the supply facilitates the use of the distributor during measurements on the ship. Additional +5V analog stabilizers were used. It allows to use the separation transformers (DC/DC) +5V/+5V.

6. Difficulties with supplying the TDC distributor

During prolonged measurements on a ship it is crucial to ensure the continuity of supplying power to the TDC distributor. Not always an AC power supply with ~230V voltage or DC with +24V voltage from the ship's power grid is available. Using additional power supply with +12V or +24V voltage is necessary in such case. To become independent of the incoming supply of power parameters, the construction of the TDC signal distributor must enable supplying in a range, e.g. 8÷35V.

This property can be achieved in a few ways:

a) a single DC/DC transformers (Fig.4) having input supply of voltage that can vary in a range of e.g. 8÷15V (while output supply is set to e.g. 5V) can be used. The quantity of such transformers should correspond to the quantity of the separated exits of the distributor,

b) analog voltage stabilizers (e.g. LM7805) (Fig.5) which input supply is in range of +7,5÷35V, while output supply is set to +5V can be used. The only inconvenience of using this solution are vast heat-losses occurring in the analog stabilizer system. The separation DC/DC 5V/5V transformers are supplied with voltage of 5V. For the analog stabilizers a proper radiators must be used. The quantity of the stabilizers and the transformers should correspond to the quantity on distributor's separated outputs,

c) a single DC/DC transformer of higher power (Fig.6) of varying supply of voltage in range of e.g. 8÷35V (having set output voltage of .e.g. 5V) can be used. All DC/DC 5V/5V separating transformers are supplied by this 5V voltage. This solution is the most economic one, having the least losses in the power system.

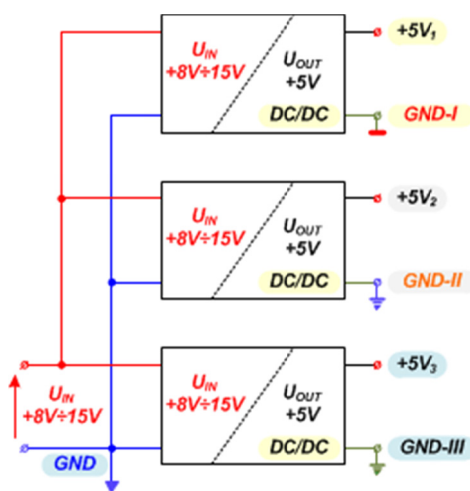

Fig. 4 Single DC/DC transformers in- output voltage supply ranging +8÷15V (having set output voltage of +5V)

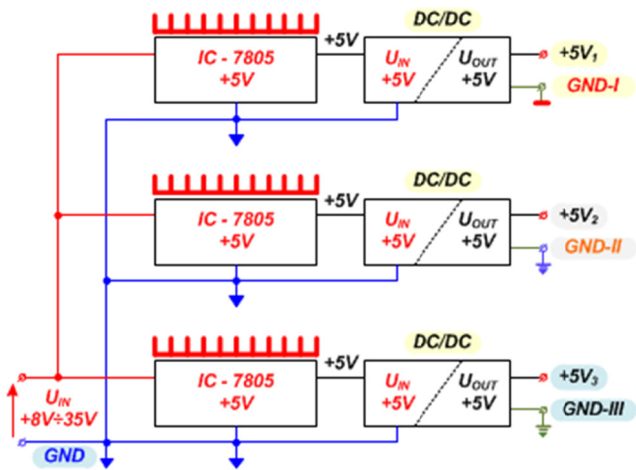

Fig. 5 Analog voltage stabilizers (e.g. LM7805) with output voltage range $+7,5\div35$, having set output voltage of $+5V$ and DC/DC $5V/5V$ separating transformers

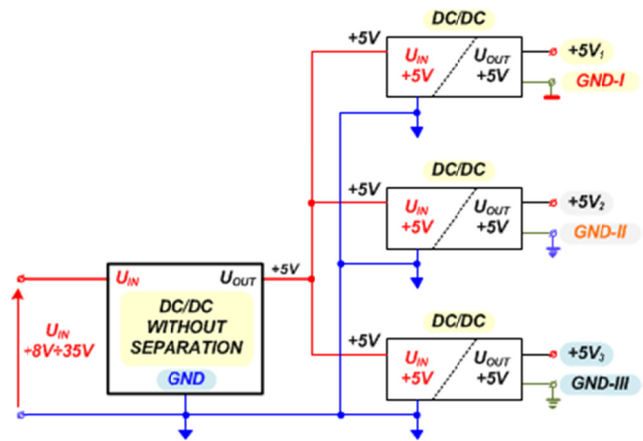

Fig. 6 A single DC/DC transformer of higher power (without separation) of output voltage range of $8\div35V$ (having set output voltage of $+5V$) and DC/DC $5V/5V$ separating transformers

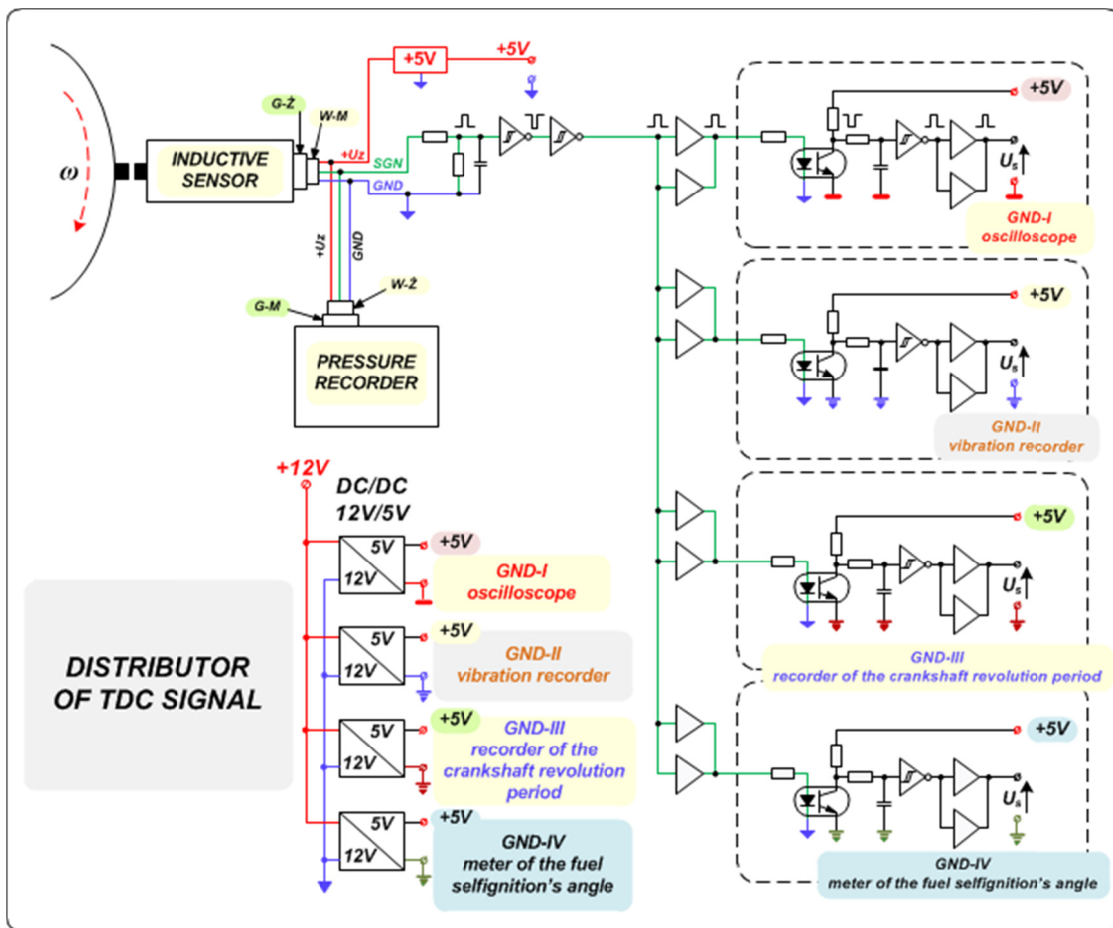

Fig. 7 Schematic diagram of TDC impulse generator



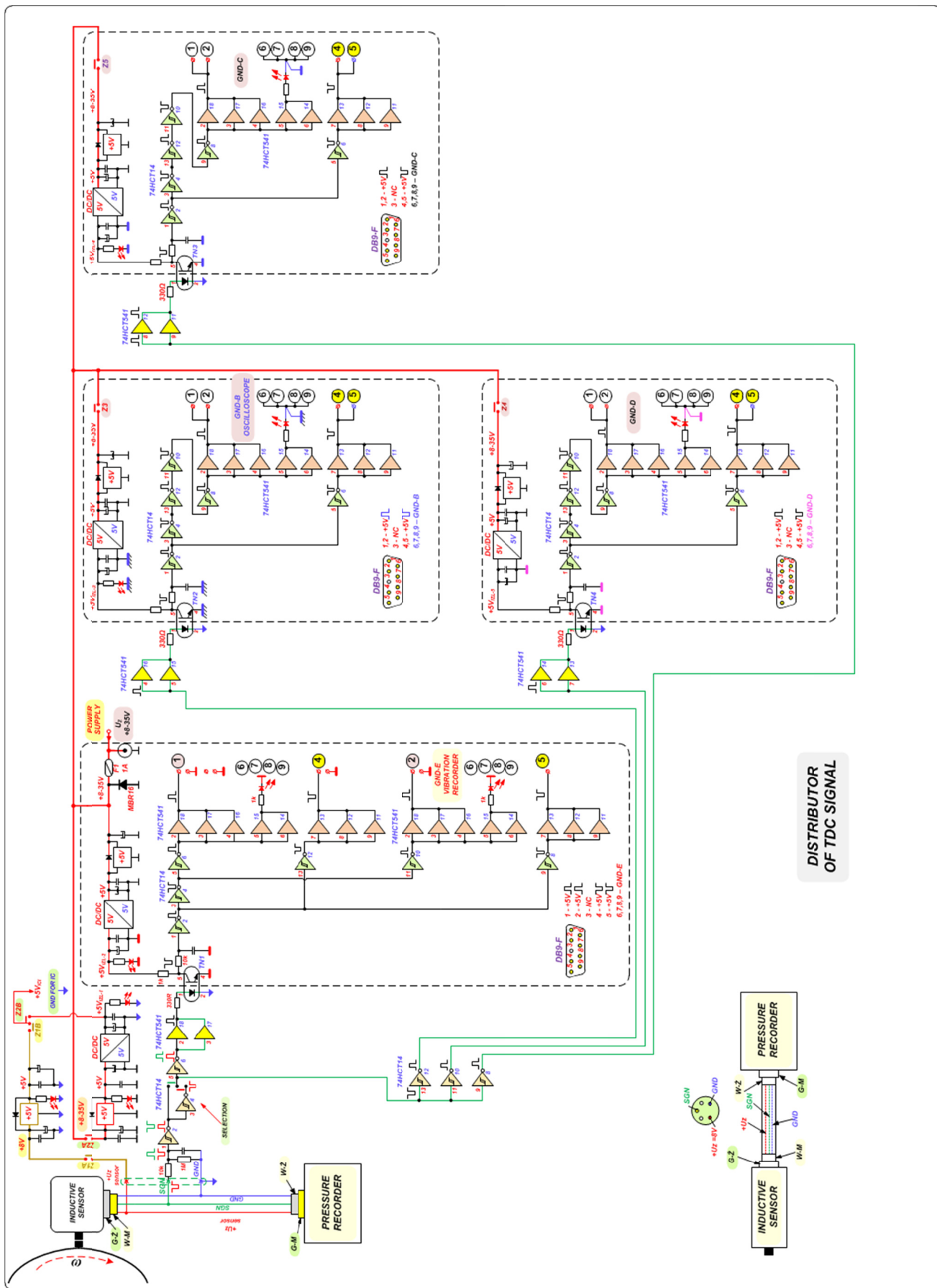

Fig.9 Schematic diagram of a TDC impulse distributor with four galvanically separated outputs with +5V amplitude

5. Application of TDC impulse distributor

Fig. 10 and 11 present examples of application of the TDC impulse distributor. These are exemplary schematic diagrams of systems of selfignition angle meter with simultaneous measurement of the pressure in the cylinder and vibration registration [1, 2].

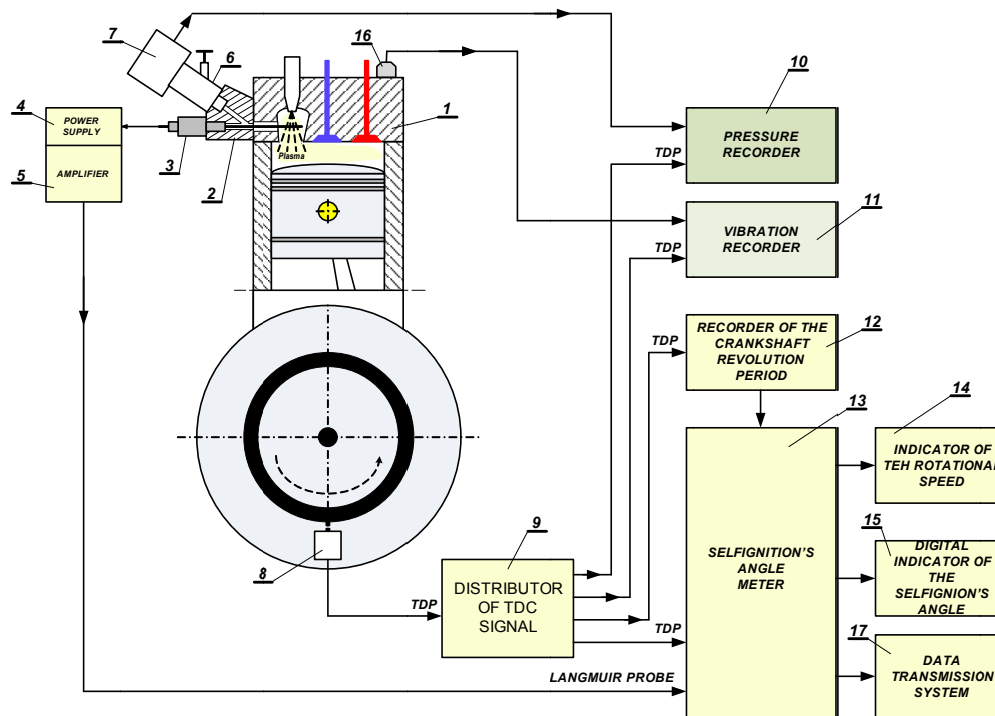
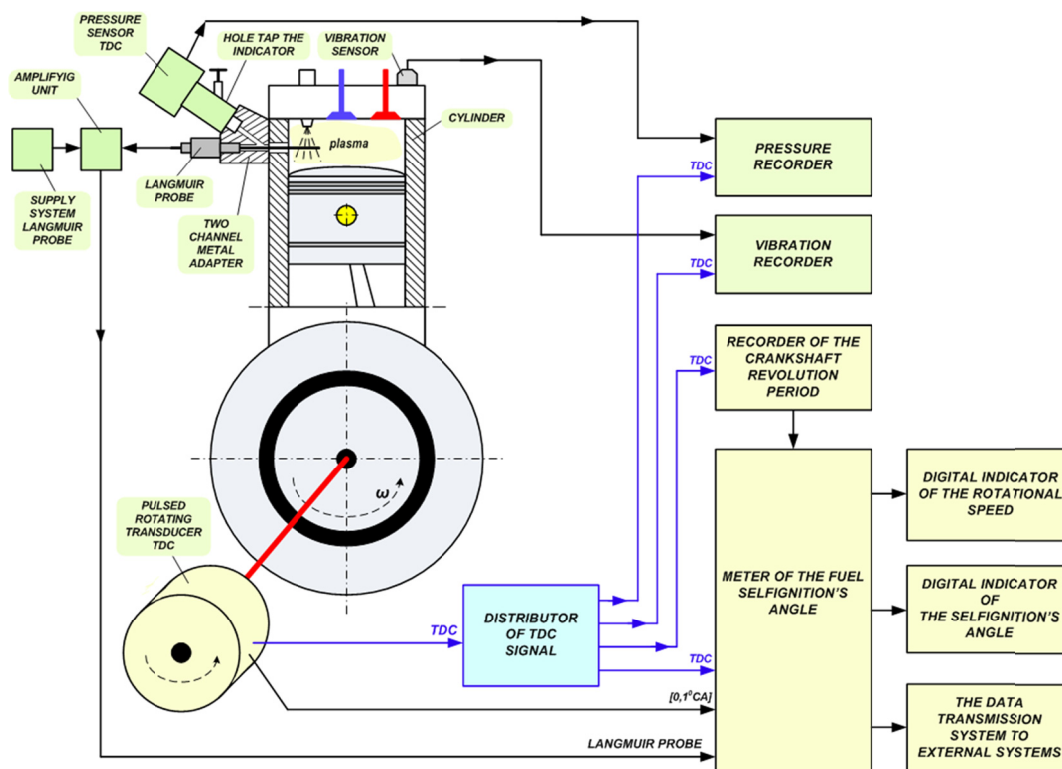

Fig.10 An example of application of TDC impulse distributor in a system of selfignition angle meter with simultaneous measurement of the pressure in the cylinder and vibration registration



Rys.11 An example of application of TDC impulse distributor in a system of selfignition angle meter (using impulse-rotation converter) with simultaneous measurement of the pressure in the cylinder and vibration registration

6. Summary

In the Fig. 12 a manufactured TDC impulse distributor is presented. Faceplate and back plate have descriptive labels, signal LED diodes, GMP output connectors, +12V socket for connection of an external power supply and tips (set of connectors) that create a signal tee to be connected to the signal for the TDC location sensor enclosed. TDC location sensor may be an inductive, optical or other kind of sensor. Predominantly it is a sensor cooperating with pressure measurer (the electric analyzer of combustion pressure).

A separate impDISTRIBUTORulse - rotation converter can be used (Fig. 11), which allows a more precise setting of moment of TDC impulse generation.

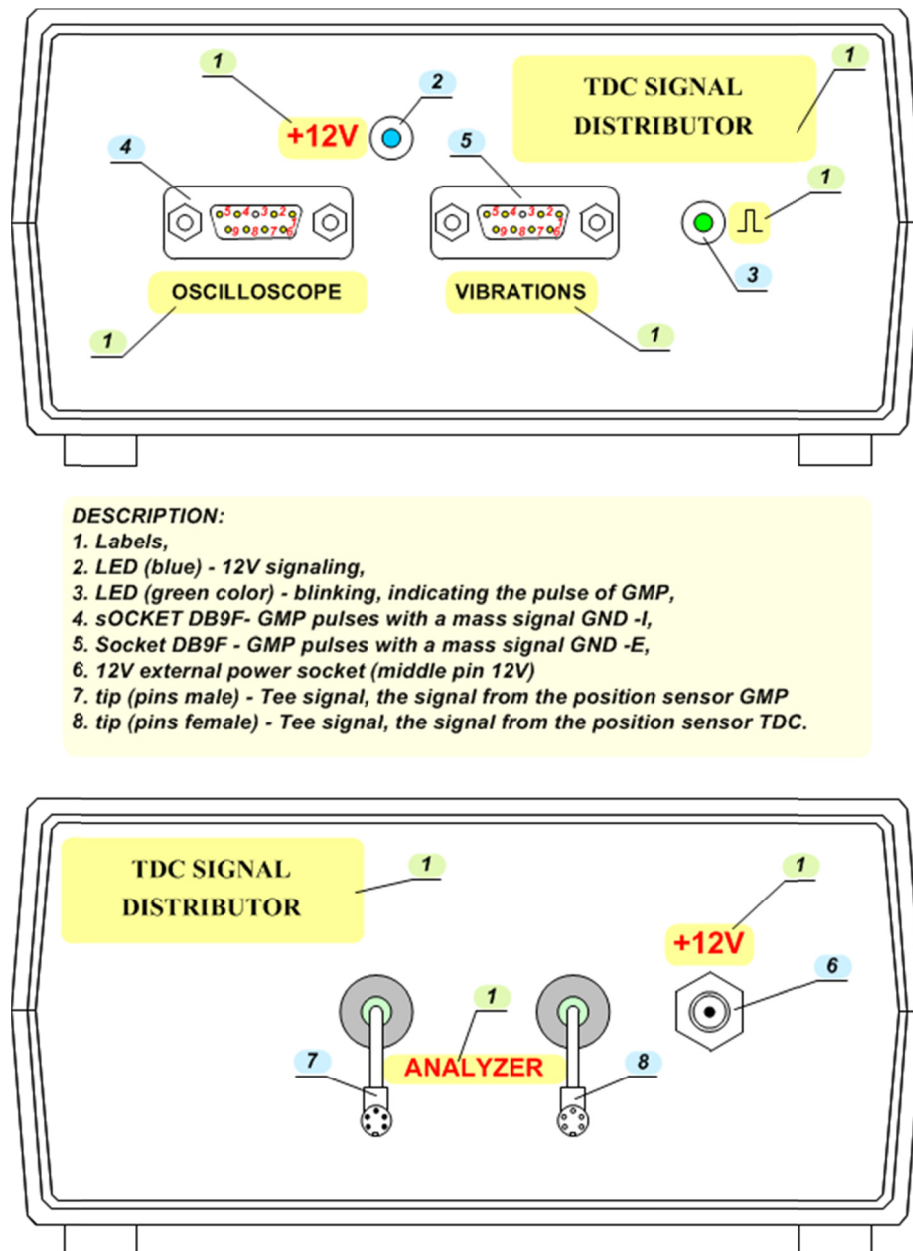

Fig. 12 The view of faceplate and back plate of the TDC impulse distributor prototype

7. Bibliography

1. Korczewski Z., Rudnicki J., Cenian A., Piechowski L.: INVESTIGATIONS OF THE LABORATORY FARYMANN DIESEL ENGINE D10 TYPE BY MEANS OF A LANG-

MUIR PROBE// Combustion Engines / Silniki Spalinowe. -Vol. 153., nr. 2 (2013), s.75-82,
AR 126320

2. Korczewski Z., Rudnicki J., Cenian A., Piechowski L.: USE OF LANGMUIR PROBE IN DIESEL ENGINE DIAGNOSTIC RESEARCH Part I MEASUREMENT TECHNOLOGY. - Part 1 : MEASUREMENT TECHNOLOGY// Journal of Polish CIMAC. -Vol. 8., nr. 3 (2013), s.41-48, *AR 126068*
3. Polanowski S., Pawletko R.: ACQUISITION OF DIAGNOSTIC INFORMATION FROM THE INDICATOR DIAGRAMS OF MARINE ENGINES USING THE ELECTRONIC INDICATORS// Journal of KONES Powertrain and Transport, Vol. 18, No. 3 2011
4. Wajand J.: Pomiary szybkozmiennych ciśnień w maszynach tłokowych// WNT// Warszawa 1974.
5. <http://www.lemag.de>

