

Rapid Yield Estimation and Optimization of Microwave Structures Exploiting Feature-Based Statistical Analysis

Slawomir Koziel, *Senior Member, IEEE*, and John W. Bandler, *Life Fellow, IEEE*

Abstract—In this paper, we propose a simple, yet reliable methodology to expedite yield estimation and optimization of microwave structures. In our approach, the analysis of the entire response of the structure at hand (e.g., S -parameters as a function of frequency) is replaced by response surface modeling of suitably selected feature points. On the one hand, this is sufficient to determine whether a design satisfies given performance specifications. On the other, by exploiting the almost linear dependence of the feature points on the designable parameters of the structure, reliable yield estimates can be realized at low computational cost. Our methodology is verified using two examples of waveguide filters and one microstrip hairpin filter and compared with conventional Monte Carlo analysis based on repetitive electromagnetic simulations, as well as with statistical analysis exploiting linear response expansions around the nominal design. Finally, we perform yield-driven design optimizations on these filters.

Index Terms—Design centering, electromagnetic (EM) modeling, microwave component modeling, statistical analysis, tolerance-aware design, yield estimation, yield-driven design.

I. INTRODUCTION

RELIABLE design of microwave components and circuits has to account for manufacturing tolerances and uncertainties. In many cases, the objective is a robust design, i.e., maximization of the probability that the fabricated structure satisfies given performance specifications under assumed deviations from the nominal values of geometry and/or material parameters (yield-driven design or design centering [1]–[6]). In this context, statistical analysis and yield estimation are indispensable steps in the design process [7]–[9].

Manuscript received April 07, 2014; revised August 18, 2014 and October 30, 2014; accepted November 12, 2014. Date of publication December 02, 2014; date of current version December 31, 2014. This work was supported in part by the Icelandic Centre for Research (RANNIS) under Grant 130450051 and Grant 141272051, by the Natural Sciences and Engineering Research Council (NSERC) of Canada under Grant RGPIN7239-11 and Grant STPGP447367-13, and by Bandler Corporation.

Color versions of one or more of the figures in this paper are available online at <http://ieeexplore.ieee.org>.

S. Koziel is with the Faculty of Electronics, Telecommunications and Informatics, Gdansk University of Technology, 80-233 Gdansk, Poland (e-mail: koziel@ru.is).

J. W. Bandler is with the Simulation Optimization Systems Research Laboratory and the Department of Electrical and Computer Engineering, McMaster University, Hamilton, ON, Canada, L8S 4K1, and also with Bandler Corporation, Dundas, ON, Canada L9H 5E7 (e-mail: bandler@mcmaster.ca).

Color versions of one or more of the figures in this paper are available online at <http://ieeexplore.ieee.org>.

Digital Object Identifier 10.1109/TMTT.2014.2373365

Except in very simple cases, accurate evaluation of microwave structures can only be obtained by full-wave electromagnetic (EM) simulations with fine discretization. This is not only due to the lack of accuracy of simplified (e.g., equivalent circuit) models, but also due to the lack of such models for modern complex structures, where various interactions between the structure and its environment have to be taken into account (e.g., housing, connectors, or in the case of antennas, installation fixtures). Unfortunately, accurate, high-fidelity EM simulation is computationally expensive so that its use for direct statistical analysis (e.g., the Monte Carlo (MC) approach involving multiple full-wave EM simulations) is normally impractical. At the same time, commonly used methods based on the analysis of a structure for extreme values in the ranges of the design parameters (worst case tolerance analysis [1]), while computationally feasible, are not able to provide meaningful statistical data for use in yield estimation.

More involved methods, e.g., those exploiting response surface approximation (RSA) models [10]–[12], or polynomial chaos expansion [13], alleviate the difficulties of the classical MC approach to some extent, however, their advantages are questionable for high-dimensional design spaces. The fundamental bottleneck here is the rapid growth of the number of data samples necessary to set up a reliable structure representation (whether it is an RSA or chaos expansion model) with the accompanying increase in the design space dimensionality. Other approaches (e.g., [14]) include the use of principal component analysis (PCA) [15] to reduce the problem complexity for high-dimensional cases, as well as surrogate-based methods such as space mapping [16], [17] or neural-space-mapping modeling [18], [19]. Space-mapping-like techniques aim at reducing the computational cost of the statistical analysis process by exploiting suitably corrected (mapped) physics-based coarse models (e.g., equivalent circuits).

In this work, we offer an alternative technique for rapid and reliable statistical analysis and yield estimation of EM-simulated microwave structures, especially filters. The original version of this method was proposed in [20]. Here, it is analyzed in depth and extended to yield-driven design (design centering).

The essence of our approach is approximation-based modeling of suitably selected features of the filter response. The features are chosen so that they can be used to uniquely determine whether or not the structure satisfies given performance requirements. The approximation model is constructed using few training designs (and, consequently, only a few corresponding EM simulations of the structure are necessary for its setup),

which grows only linearly with the dimensionality of the design space. As comprehensively demonstrated using three filter examples, our proposed technique facilitates reliable yield estimates at low computational cost. We also include a comparison with direct statistical analysis using the classical MC approach. Furthermore, it is shown that our feature-based yield estimation is conceptually different from that derived from linear expansions around the nominal design point (the latter resulting in dramatic yield underestimation). Finally, we demonstrate the possibility of low-cost yield-driven design using a modified version of our proposed technique.

II. YIELD ESTIMATION USING RESPONSE FEATURES

In this section, we formulate the yield estimation technique exploiting suitable response features. We also provide some background information to explain the effectiveness of our approach, specifically regarding the high predictive power of the feature-based model utilized by the proposed statistical analysis procedure. Applications to yield-driven design are discussed in Section IV.

A. Yield Estimation of Microwave Structures

We denote by $\mathbf{R}(\mathbf{x})$ a response of a device or component of interest (such as a filter), representing, for example, EM-simulated S -parameters versus frequency. Here, \mathbf{x} is a vector of designable (e.g., geometry or material) parameters. Let $\mathbf{x}^0 = [x_1^0 x_2^0 \dots x_n^0]^T$ be a nominal design (typically, an optimum design with respect to given performance specifications). It is assumed that due to manufacturing uncertainties, the actual parameters of the fabricated device are $\mathbf{x}^0 + d\mathbf{x}$, where a random deviation $d\mathbf{x} = [dx_1 \dots dx_2 dx_n]^T$ is described by a given probability distribution (such as a Gaussian distribution with zero mean and a certain standard deviation) or a uniform distribution with certain lower and upper bounds, e.g., $dx_k \in [-d_{k,\max} d_{k,\max}]$, $k = 1, \dots, n$.

We define an auxiliary function $H(\mathbf{x})$ as follows [7]:

$$H(\mathbf{x}) = \begin{cases} 1, & \text{if } \mathbf{R}(\mathbf{x}) \text{ satisfies the design specifications} \\ 0, & \text{otherwise.} \end{cases} \quad (1)$$

The yield at the nominal design \mathbf{x}^0 can then be estimated as

$$Y(\mathbf{x}^0) = \frac{\sum_{j=1}^N H(\mathbf{x}^0 + d\mathbf{x}^j)}{N} \quad (2)$$

where $d\mathbf{x}^j$, $j = 1, \dots, N$ are random vectors sampled according to the assumed probability distribution. Obviously, evaluating (2) by means of multiple EM simulations of the perturbed nominal design may be extremely expensive, particularly because reliable yield estimation requires a large number of samples (typically, a few hundred or more). In the case of small yield values, the number of samples have to be even larger (a few thousand or more) in order to avoid high variance of the estimator.

B. Feature-Based Approximation Model

In this work, we estimate the yield using the concept of feature points, introduced in [21] in the context of shape-preserving response prediction (SPRP). Let us consider $|S_{11}|$ responses (cf. Fig. 1) of the bandpass filter considered in Section III. The plot

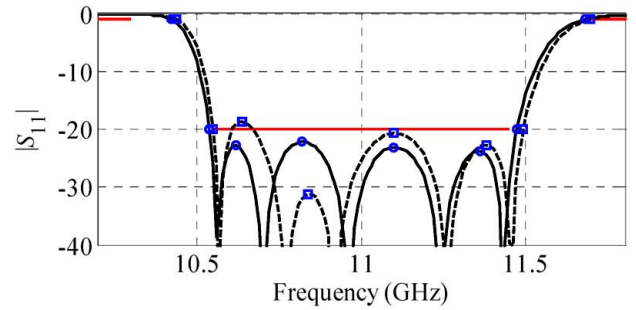

Fig. 1. Reflection response of the bandpass filter (—) at the optimum design with respect to given minimax specifications (marked with horizontal lines), as well as the response at a perturbed design (---). Circles and squares denote feature points for both responses, here, corresponding to the -1 - and -20 -dB levels, as well as the response maxima in the passband. Design specifications are: $|S_{11}| \leq -20$ dB for 10.55 to 11.45 GHz, and $|S_{11}| \geq -1$ dB for frequencies lower than 10.3 GHz and higher than 11.7 GHz.

shows the response at the nominal design (i.e., a typically desired minimax optimum with respect to the design specifications marked with horizontal lines, here, $|S_{11}| \leq -20$ dB for 10.55–11.45 GHz, and $|S_{11}| \geq -1$ dB for frequencies lower than 10.3 GHz and higher than 11.7 GHz), as well as a set of so-called feature points, here, represented by -1 - and -20 -dB levels, as well as the peaks of the response in the passband. The location of these points is sufficient to determine whether the response violates or satisfies the given design specifications. In particular, assuming small design perturbations, the feature points corresponding to -1 and -20 dB may move towards lower or higher frequencies violating (in some cases) the specifications regarding passband and/or stopband frequencies; the feature points corresponding to $|S_{11}|$ maxima in the passband may move up leading to violation of the $|S_{11}| \leq -20$ requirement.

The choice of feature points for a given problem is straightforward. Fig. 1 also shows the response and the corresponding feature points at a perturbed design (which, in this case, violates our specifications).

As indicated in [22], modeling feature points is significantly easier than constructing response surfaces for entire responses. This is because the dependence of both the frequency and vertical locations of those points on respective designable parameters is much less nonlinear than for the S -parameters modeled (conventionally) as functions of frequency. As a result, only a limited number of training samples is necessary for creating such models, particularly if we are only interested in local approximations (i.e., around the nominal design).

It should also be emphasized that—unlike in the case of SPRP [21]—we are not interested in an accurate prediction of the entire response of the structure. The focus is on those critical parts of the response where the design specifications can potentially be violated. This significantly simplifies the modeling process.

In order to construct our model, we consider $2n + 1$ evaluations of the original model \mathbf{R} at the nominal design, $\mathbf{R}(\mathbf{x}^0)$, and at the perturbed designs $\mathbf{x}^k = [x_{0,1} \dots x_{0,k} + \text{sign}(k) \cdot \delta_k \dots x_{0,n}]^T$, $k = -n, \dots, -1, 1, \dots, n$, where δ_k may be, for example, a maximum assumed deviation of the k th parameter from its nominal value. The feature points of the response vector $\mathbf{R}(\mathbf{x}^k)$ are denoted as $\mathbf{p}_k^j = [f_k^j r_k^j]^T$, $j = 1, \dots, K$,

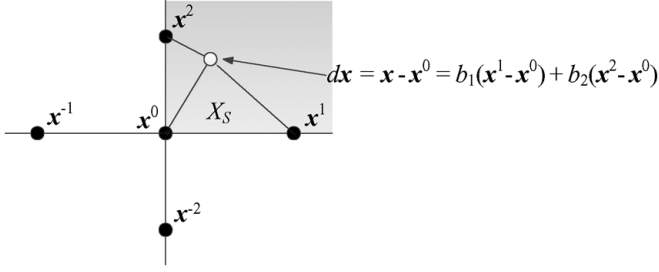

Fig. 2. Deviation vector $d\mathbf{x}$ and its expansion using star-distributed training vectors \mathbf{x}^k , $k = -2, -1, 1, 2$ (denoted as \bullet). The shaded area denotes an area defined by a subset X_S of points being the closest to $\mathbf{x}^0 + d\mathbf{x}$, which is represented as a linear combination of vectors $\mathbf{x}^k - \mathbf{x}^0$. The feature points at $\mathbf{x}^0 + d\mathbf{x}$ are calculated using the coefficients of this linear combination and the feature points of $\mathbf{R}(\mathbf{x}^k)$ for $\mathbf{x}^k \in X_S$. Here, we have $\mathbf{p}^j = \mathbf{p}_0^j + \beta_1(\mathbf{p}_1^j - \mathbf{p}_0^j) + \beta_2(\mathbf{p}_2^j - \mathbf{p}_0^j)$.

where f and r are the frequency and magnitude components of the respective point, and where K is the total number of feature points.

The aim is to predict the position of the feature points corresponding to a perturbed vector $\mathbf{x}^0 + d\mathbf{x}$ using the available training set $\{\mathbf{x}^k; \mathbf{p}_{-n}^j, \dots, \mathbf{p}_{-1}^j, \mathbf{p}_0^j, \mathbf{p}_1^j, \dots, \mathbf{p}_n^j\}$. For any given $d\mathbf{x}$, we find a subset X_S of the base set $\{\mathbf{x}^k\}$ that defines an area containing $\mathbf{x}^0 + d\mathbf{x}$. The surrogate model is set up using all the points from X_S , as shown in Fig. 2 for $n = 2$. Without loss of generality, we can assume that $X_S = \{\mathbf{x}^0, \mathbf{x}^1, \dots, \mathbf{x}^n\}$. We define

$$\mathbf{p}^j = \mathbf{p}_0^j + \beta_1(\mathbf{p}_1^j - \mathbf{p}_0^j) + \beta_2(\mathbf{p}_2^j - \mathbf{p}_0^j) + \dots + \beta_n(\mathbf{p}_n^j - \mathbf{p}_0^j) \quad (3)$$

where $\beta_1, \beta_2, \dots, \beta_n$ determines a unique representation of $d\mathbf{x}$ using vectors $\mathbf{v}_i = \mathbf{x}^i - \mathbf{x}^0$, $i = 1, \dots, n$. Coefficients β_i can be explicitly found as [9]

$$[\beta_1 \beta_2 \dots \beta_n]^T = [\mathbf{v}_1 \mathbf{v}_2 \dots \mathbf{v}_n]^{-1} \cdot (\mathbf{x} - \mathbf{x}^0). \quad (4)$$

Using (3) and (4), we can define an approximation model of the feature points as

$$s(\mathbf{x}^0 + d\mathbf{x}) = [\mathbf{p}^1(\mathbf{x}^0 + d\mathbf{x}) \dots \mathbf{p}^K(\mathbf{x}^0 + d\mathbf{x})] \quad (5)$$

where $\mathbf{p}^j(\mathbf{x}^0 + d\mathbf{x}) = [f^j(\mathbf{x}^0 + d\mathbf{x}) \ r^j(\mathbf{x}^0 + d\mathbf{x})]^T$, $j = 1, \dots, K$. Having $s(\mathbf{x}^0 + d\mathbf{x})$, one can estimate yield in a way similar to (1) and (2). The fundamental difference is that the satisfaction/violation of the design specification frequencies/levels is verified for the feature points only rather than for the entire responses.

C. Inadequacy of Linear Expansion Models

It should be emphasized that using response features for estimating yield rather than constructing, for example, a linear model of the entire S -parameter response is critical to accuracy. Let us consider a simple first-order Taylor expansion of the filter model around the nominal design \mathbf{x}^0

$$\mathbf{R}_L(\mathbf{x}) = \mathbf{R}(\mathbf{x}^0) + \mathbf{J}_R(\mathbf{x}^0) \cdot (\mathbf{x} - \mathbf{x}^0) \quad (6)$$

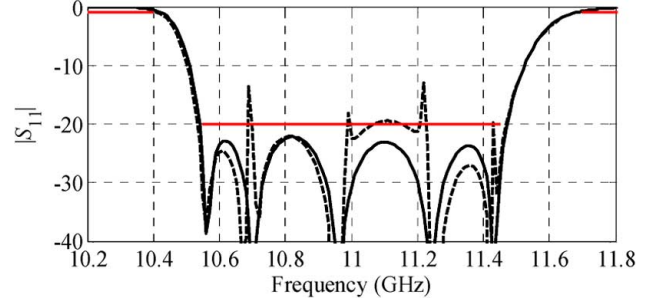

Fig. 3. Fifth-order bandpass filter of Section III-A: the filter response at the nominal design (—) and the response obtained from a linear model (6) constructed using a perturbed design (---) (at the selected reference design). The spikes that appear due to the linear modeling of sharp responses lead to considerable yield underestimation (cf. Table I).

TABLE I
YIELD ESTIMATION: FIFTH-ORDER WAVEGUIDE FILTER

Case	Distribution	Yield Estimation Method	Estimated Yield	CPU Cost ²
1	Uniform (max. dev. 0.01 mm)	Feature points (this work)	0.97	19
		EM-based Monte Carlo	0.97	500
		Linear modeling ¹	0.63	19
2	Uniform (max. dev. 0.02 mm)	Feature points (this work)	0.56	19
		EM-based Monte Carlo	0.55	500
		Linear modeling ¹	0.12	19
3	Gaussian (std. dev. 0.01 mm)	Feature points (this work)	0.69	19
		EM-based Monte Carlo	0.69	500
		Linear modeling ¹	0.19	19
4	Gaussian (std. dev. 0.02 mm)	Feature points (this work)	0.25	19
		EM-based Monte Carlo	0.24	500
		Linear modeling ¹	0.02	19

¹ Estimation based on a linear model of the S -parameter response around the nominal design; ² Estimation cost in number of EM analyses. Feature-based yield estimation utilizes $N = 5000$ random samples.

where $\mathbf{J}_R(\mathbf{x}^0)$ is an estimated Jacobian of \mathbf{R} at the nominal design. The estimate can be obtained using evaluations of \mathbf{R} at the perturbed designs \mathbf{x}^k considered in Section II-B.

Fig. 3 shows an S -parameter prediction obtained by evaluating a linear surrogate \mathbf{R}_L constructed from the filter responses evaluated for the same training set used for the feature-based model. The lack of accuracy coming from the very sharp responses (as functions of frequency) is reflected in underestimated yield predictions (cf. Section III). This indicates that the feature-based yield estimation, although based on the same data set) is fundamentally different from simple linear modeling.

It should be mentioned that a number of sophisticated methods for parametric macromodeling (e.g., [23] and [24]) or stochastic macromodeling (e.g., [25] and [26]) can be found in the literature that allow for avoiding the presence of abnormal responses of the simple linear model (6) through, for example, passivity enforcement. Here, model (6) was only used in order to indicate that the “naïve” utilization of the small data set exploited by the feature-based model leads to very poor predictions.

III. VERIFICATION EXAMPLES

In this section, the proposed yield estimation methodology is comprehensively validated using two waveguide filter examples and one microstrip filter. A comparison with the conventional

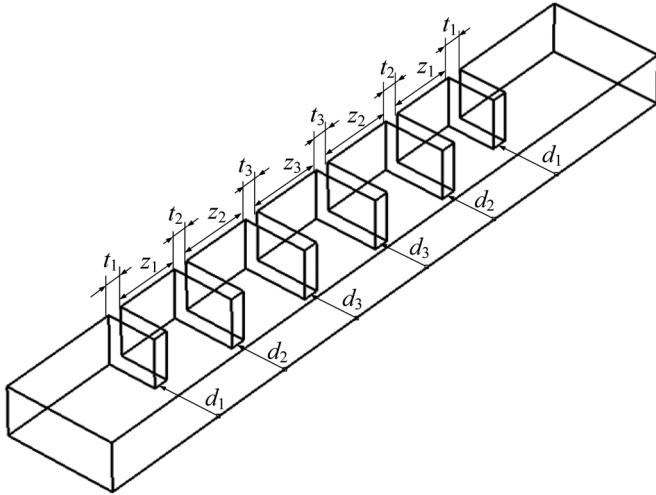

Fig. 4. Fifth-order waveguide bandpass filter [27].

MC analysis is also included. An extension of our method to yield-driven design is discussed in Section IV.

A. Fifth-Order Chebyshev Waveguide Bandpass Filter

Consider the X-band waveguide filter with nonsymmetrical irises [27] shown in Fig. 4. The design variables are $\mathbf{x} = [z_1 \ z_2 \ z_3 \ d_1 \ d_2 \ d_3 \ t_1 \ t_2 \ t_3]^T$. The filter is simulated in CST [28] ($\sim 140\,000$ tetrahedrons, simulation time about 8 min). The nominal design, $\mathbf{x}^0 = [12.0836 \ 14.2069 \ 14.6875 \ 13.9841 \ 11.6864 \ 10.8076 \ 1.5455 \ 3.0671 \ 2.4557]^T$ mm, is a minimax optimum with respect to the following design specifications: $|S_{11}| \leq -20$ dB for $10.55 \text{ GHz} \leq \omega \leq 11.45 \text{ GHz}$ and $|S_{11}| \geq -1$ dB for $\omega \leq 10.4 \text{ GHz}$ and $\omega \geq 11.7 \text{ GHz}$. The minimax optimization is understood as minimization of a maximum violation of the aforementioned design specifications within the respective frequency sub-bands.

Yield estimation has been carried out using four scenarios for geometry parameter deviations, including a uniform probability distribution with a maximum deviation equal to 0.01 and 0.02 mm (Cases 1 and 2) and a normal distribution with zero mean and standard deviation of 0.01 and 0.02 mm (Cases 3 and 4). The deviations are taken as uncorrelated. The yield has been estimated with the methodology described in Section II, using the eight feature points shown in Fig. 1.

For comparison, the yield was also estimated using conventional MC analysis with 500 random samples (the number of samples is limited due to the computational cost of the EM simulation). The results are shown in Table I. Fig. 5 presents a visualization of the yield estimation for Case 2. The agreement between the yield estimation obtained using our proposed method and conventional MC analysis is excellent. As a matter of fact, the results obtained using our approach are more reliable than MC: the uncertainty in the latter is relatively large due to the small number of samples used in the process to keep the cost low. Feature-based yield estimation was executed for $N = 5000$.

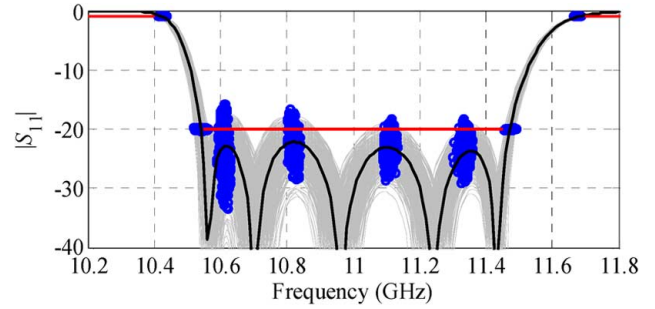

Fig. 5. Fifth-order waveguide bandpass filter: yield estimation for Case 2. Gray lines correspond to 500 EM-simulated random samples for MC analysis, circles represent corresponding feature points calculated using the approximation model (1)–(5).

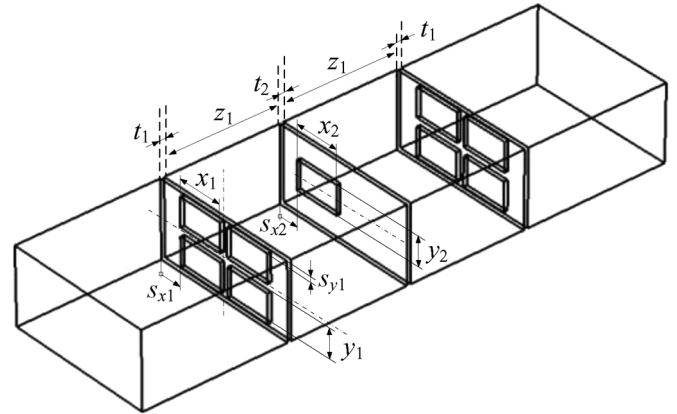

Fig. 6. Coupled iris waveguide filter [29].

B. Coupled Iris Waveguide Filter

Consider the coupled iris filter [29] shown in Fig. 6. The design variables are $\mathbf{x} = [z_1 \ x_1 \ x_2 \ s_{x1} \ s_{x2} \ s_{y1} \ s_{y2} \ z_{t1} \ z_{t2}]^T$. The filter is simulated in CST [28] ($\sim 60\,000$ tetrahedron mesh cells, simulation time 5 min). The nominal design, $\mathbf{x}^0 = [11.1934 \ 5.2988 \ 6.0991 \ 2.4996 \ 1.0112 \ 0.29860 \ 1.503 \ 0.3608 \ 0.2266]^T$ mm, is a minimax optimum with respect to the following design specifications: $|S_{11}| \leq -20$ dB for $14.85 \text{ GHz} \leq \omega \leq 15.15 \text{ GHz}$ and $|S_{11}| \geq -1$ dB for $\omega \leq 14.4 \text{ GHz}$ and $\omega \geq 15.6 \text{ GHz}$. The yield has been estimated for six scenarios for geometry parameter deviations as indicated in Table II (see also Fig. 7). The results confirm that our technique ensures reliable yield prediction at a fraction of the cost required by the conventional approach.

C. Microstrip Hairpin Filter

Consider the microstrip hairpin filter [30] shown in Fig. 8. The design variables are $\mathbf{x} = [L_1 \ L_2 \ L_3 \ L_4 \ L_5 \ L_6 \ s_1 \ s_2 \ d]^T$. The microstrip width is fixed to $w = 1.5$ mm. The substrate parameters are $h = 0.787$ mm (substrate height) and $\epsilon_r = 3.38$ (dielectric permittivity). The filter is simulated in FEKO [31] (~ 900 mesh cells, simulation time 15 min). The nominal design, $\mathbf{x}^0 = [9.357 \ 11.684 \ 9.814 \ 0.402 \ 0.507 \ 1.514 \ 0.053 \ 0.130 \ 0.182]^T$ mm, is a design optimized with respect to the following specifications: $|S_{11}| \leq -16$ dB for $3.6 \text{ GHz} \leq \omega$

TABLE II
YIELD ESTIMATION: COUPLED IRIS WAVEGUIDE FILTER

Case	Distribution	Yield Estimation Method	Estimated Yield	CPU Cost ²
1	Uniform (max. dev. 0.005 mm)	Feature points (this work)	0.68	19
		EM-based Monte Carlo	0.69	500
		Linear modeling ¹	0.57	19
2	Uniform (max. dev. 0.01 mm)	Feature points (this work)	0.32	19
		EM-based Monte Carlo	0.34	500
		Linear modeling ¹	0.19	19
3	Uniform (max. dev. 0.02 mm)	Feature points (this work)	0.09	19
		EM-based Monte Carlo	0.10	500
		Linear modeling ¹	0.01	19
4	Gaussian (std. dev. 0.005 mm)	Feature points (this work)	0.43	19
		EM-based Monte Carlo	0.44	500
		Linear modeling ¹	0.30	19
5	Gaussian (std. dev. 0.01 mm)	Feature points (this work)	0.15	19
		EM-based Monte Carlo	0.16	500
		Linear modeling ¹	0.05	19
6	Gaussian (std. dev. 0.02 mm)	Feature points (this work)	0.095	19
		EM-based Monte Carlo	0.102	500
		Linear modeling ¹	0.006	19

¹ Estimation based on a linear model of the S -parameter response around the nominal design; ² Estimation cost in number of EM analyses. Feature-based yield estimation utilizes $N = 5000$ random samples.

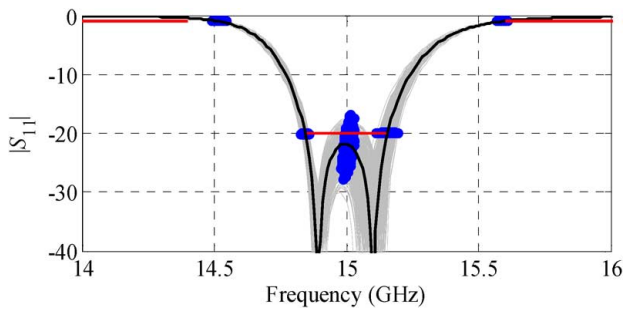

Fig. 7. Coupled iris waveguide filter: yield estimation for Case 2. Gray lines correspond to 500 EM-simulated random samples for MC analysis, circles represent corresponding feature points calculated using the approximation model (1)–(5).

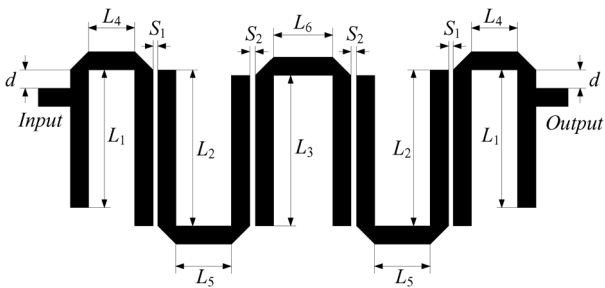

Fig. 8. Microstrip hairpin filter: geometry [30].

≤ 4.4 GHz and $|S_{11}| \geq -1$ dB for $\omega \leq 3.4$ GHz and $\omega \geq 4.6$ GHz.

For this last example, the yield has been estimated using four scenarios of uncertainties in the geometry parameters, as shown in Table III. Fig. 9 shows a visualization of yield estimation for the selected case. Our results are consistent with the previous examples in terms of agreement with the MC analysis, however, the prediction of yield given by the proposed method is lower than for MC. It should be emphasized that in this case,

TABLE III
YIELD ESTIMATION: MICROSTRIP HAIRPIN FILTER

Case	Distribution	Yield Estimation Method	Estimated Yield	CPU Cost ²
1	Uniform (max. dev. 0.01 mm)	Feature points (this work)	0.18	19
		EM-based Monte Carlo	0.19	500
		Linear modeling ¹	0.07	19
2	Uniform (max. dev. 0.02 mm)	Feature points (this work)	0.032	19
		EM-based Monte Carlo	0.040	500
		Linear modeling ¹	0.014	19
3	Gaussian (std. dev. 0.01 mm)	Feature points (this work)	0.102	19
		EM-based Monte Carlo	0.110	500
		Linear modeling ¹	0.002	19
4	Gaussian (std. dev. 0.02 mm)	Feature points (this work)	0.021	19
		EM-based Monte Carlo	0.026	500
		Linear modeling ¹	0.000	19

¹ Estimation based on a linear model of the S -parameter response around the nominal design; ² Estimation cost in number of EM analyses. Feature-based yield estimation utilizes $N = 5000$ random samples.

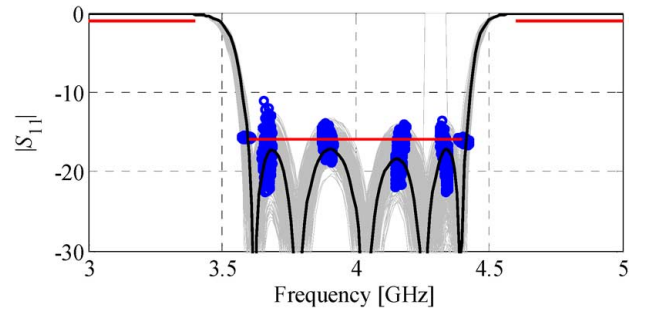

Fig. 9. Microstrip hairpin filter: yield estimation for Case 1. Gray lines correspond to 500 EM-simulated random samples for MC analysis, circles represent corresponding feature points calculated using the approximation model (1)–(5).

the yield estimation with MC based on 500 samples is not particularly reliable due to low overall values of the yield. For example, in Case 2 (a Gaussian distribution with standard deviation of 0.02 mm), the standard deviation of the estimated yield exceeds 50% of the mean value (based on multiple yield estimates obtained using the proposed method with 500 samples). To the contrary, because of its speed (once the model (5) is established, its evaluation cost is negligible), our approach allows any number of samples, which greatly improves the yield estimation accuracy.

IV. TOLERANCE-AWARE DESIGN OPTIMIZATION USING RESPONSE FEATURES

In this section, we describe the use of the methodology of Section II for cost-efficient tolerance-aware microwave design optimization (design centering).

A. Yield Maximization Methodology

As demonstrated in Section III, our proposed feature-based yield estimation technique ensures very good accuracy at low computational cost. Thus, the feature approximation model (5) can be utilized for tolerance-aware design. Let $Y_s(\mathbf{x}^0)$ denote the yield estimated at the nominal design \mathbf{x}^0 using multiple evaluations of the feature model s , as explained in Section II-B. The yield estimation is based on multiple evaluations of this model, i.e., $s(\mathbf{x}^0 + d\mathbf{x}^k)$, where $d\mathbf{x}^k$, $k = 1, \dots, N$, are random vectors

sampled according to the assumed probability distribution (cf. Section II-A).

One can define a function $Y_s(\mathbf{x}; \mathbf{x}^0)$ realizing a yield estimation for any design \mathbf{x} (in practice, \mathbf{x} should be in the vicinity of \mathbf{x}^0), where the yield is calculated using evaluations of $s(\mathbf{x} + d\mathbf{x}^k)$. However, because s is defined with respect to \mathbf{x}^0 rather than an arbitrary \mathbf{x} , the yield estimation has to be performed using the following set of evaluations: $s(\mathbf{x}^0 + d\mathbf{x}^k)$, where $d\mathbf{x}^k = d\mathbf{x}^k + [\mathbf{x} - \mathbf{x}^0]$, $k = 1, \dots, N$.

The design that maximizes the yield is then found as

$$\mathbf{x}^* = \arg \min_{\mathbf{x}} \{-Y_s(\mathbf{x}; \mathbf{x}^0)\}. \quad (7)$$

It should be emphasized that to ensure reliability (in particular, to minimize the yield estimation variance), a large number of samples should be used. In our numerical experiments, we set $N = 5000$. The same sample set of perturbations $\{d\mathbf{x}^k\}$ should also be utilized for all evaluations of $Y_s(\mathbf{x}; \mathbf{x}^0)$ in order to avoid numerical noise related to yield estimation variance.

In practice, the accuracy of a yield estimate using $Y_s(\mathbf{x}; \mathbf{x}^0)$ will degrade as \mathbf{x} moves away from \mathbf{x}^0 so yield optimization should preferably be implemented as an iterative process, namely,

$$\mathbf{x}^{i+1} = \arg \min_{\mathbf{x}} \{-Y_s(\mathbf{x}; \mathbf{x}^i)\} \quad (8)$$

where $\mathbf{x}^i, i = 0, 1, \dots$, are approximations of \mathbf{x}^* obtained by optimizing $Y_s(\mathbf{x}; \mathbf{x}^i)$, i.e., a yield estimation function set up similarly to $Y_s(\mathbf{x}; \mathbf{x}^0)$, but centered around \mathbf{x}^i rather than \mathbf{x}^0 and using corresponding perturbations. The cost of each iteration is $2n + 1$ EM simulations, where n is the number of designable parameters. The procedure is terminated when the current iteration does not lead to yield improvement, which is understood as $Y_s(\mathbf{x}^{i+1}; \mathbf{x}^{i+1}) > Y_s(\mathbf{x}^i; \mathbf{x}^i)$. The feature-based model Y_s [cf. (8)] is optimized using a pattern search algorithm [32].

Although this section only covers yield optimization starting from a certain nominal design (here, minimax optimum with respect given lower/upper specifications at selected frequencies), it is recommended that when starting from an arbitrary initial design, the yield-driven optimization is split into two separate steps, which are: 1) a conventional minimax-type optimization executed to find the nominal design and 2) a yield-driven stage as described in this section. The first step can be realized, for the sake of computational efficiency, using, for example, space mapping [33] or other type of surrogate-based optimization technique [33].

B. Application Example: Yield Optimization of Fifth-Order Waveguide Filter

The yield optimization procedure has been applied to the waveguide filter of Section III-A, assuming a Gaussian probability distribution with a standard deviation equal to 0.02 mm (Case 4). The optimization is started from the nominal design \mathbf{x}^0 (cf. Section III-A) with an estimated yield of 0.25. The optimized design is $\mathbf{x}^* = [12.05 \ 14.18 \ 14.67 \ 14.06 \ 11.74 \ 10.85 \ 1.49 \ 3.03 \ 2.46]^T$ with an estimated yield of 0.46. This design was obtained in four iterations of our yield optimization procedure at a total cost of $4 \times 19 = 76$ filter evaluations. Fig. 10 shows a visualization

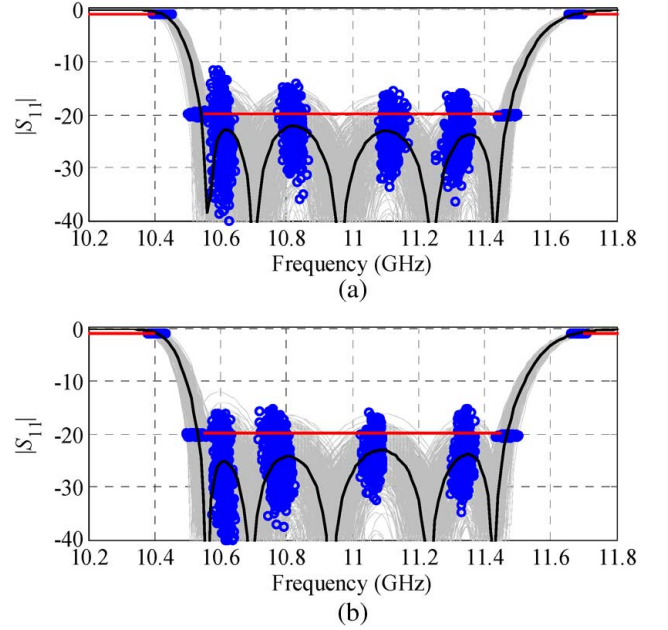

Fig. 10. Fifth-order waveguide filter: yield estimation assuming a Gaussian probability distribution with standard deviations of 0.02 mm (Case 4) at: (a) the nominal design ($Y = 0.25$) and (b) the optimized design ($Y = 0.46$). Gray lines correspond to 500 EM-simulated random samples for MC analysis, circles represent corresponding feature points calculated using the approximation model (1)–(5).

TABLE IV
YIELD OPTIMIZATION: FIFTH-ORDER WAVEGUIDE FILTER

Case ¹	Yield Estimation Method	Estimated Yield	CPU Cost ²
Nominal design (minimax optimum)	Feature points (this work)	0.25	19
	EM-based Monte Carlo	0.24	500
Yield-optimized design	Feature points (this work)	0.46	19
	EM-based Monte Carlo	0.47	500

¹ Estimation for a uniform distribution with maximum deviations of 0.01 mm.

² Estimation cost in number of EM analyses.

TABLE V
YIELD OPTIMIZATION: MICROSTRIP HAIRPIN FILTER

Case ¹	Yield Estimation Method	Estimated Yield	CPU Cost ²
Nominal design (minimax optimum)	Feature points (this work)	0.18	19
	EM-based Monte Carlo	0.19	500
Yield-optimized design	Feature points (this work)	0.25	19
	EM-based Monte Carlo	0.28	500

¹ Estimation for a uniform distribution with maximum deviations of 0.01 mm.

² Estimation cost in number of EM analyses.

of the yield estimate at the optimized design. Table IV indicates the yield estimated using both our method and conventional MC analysis. Good agreement between the two estimations is observed.

C. Application Example: Yield Optimization of Microstrip Hairpin Filter

Yield optimization for the hairpin filter (cf. Section III-C) was executed for Case 1 (a uniform probability distribution

with a maximum deviation equal to 0.01 mm). The optimized design, $\mathbf{x}^* = [9.141 \ 11.725 \ 9.84 \ 0.436 \ 0.607 \ 1.576 \ 0.030 \ 0.107 \ 0.266]^T$, with an estimated yield of 0.25 is obtained in two iterations (total cost $2 \times 19 = 38$ filter simulations). Table V indicates the yield estimated using both our method and conventional MC analysis.

V. CONCLUSIONS

A reliable technique for low-cost statistical analysis of microwave structures has been presented. Our approach exploits feature-based approximation models constructed using a limited number of EM simulations of the structure of interest. Comprehensive numerical experiments indicate excellent agreement between the statistical analysis results obtained with our approach and conventional MC simulations. The application of our approach to yield-driven design is also demonstrated.

Our proposed methodology seems to be an interesting alternative approach to expedite statistical analyses of filter structures. An important advantage is that its computational cost depends linearly on the dimensionality of the design space, which is not the case for most of the known techniques, including some of the recent methods that exploit RSA models or polynomial chaos expansions. At the same time, our method can be easily adopted in yield-driven design optimization, as demonstrated using examples of both waveguide and planar filters.

REFERENCES

- [1] J. W. Bandler, P. C. Liu, and H. Tromp, "A nonlinear programming approach to optimal design centering, tolerancing and tuning," *IEEE Trans. Circuits Syst.*, vol. CAS-23, no. 3, pp. 155–165, Mar. 1976.
- [2] J. W. Bandler, P. C. Liu, and H. Tromp, "Integrated approach to microwave design," *IEEE Trans. Microw. Theory Techn.*, vol. MTT-24, no. 9, pp. 584–591, Sep. 1976.
- [3] H. L. Abdel-Malek and J. W. Bandler, "Yield estimation for efficient design centering assuming arbitrary statistical distributions," *Int. J. Circuit Theory Appl.*, vol. 6, pp. 289–303, 1978.
- [4] M. A. Styblinski and L. J. Oplaski, "Algorithms and software tools for IC yield optimization based on fundamental fabrication parameters," *IEEE Trans. Comput.-Aided Design Integr. Circuits Syst.*, vol. CAD-5, no. 1, pp. 79–89, Jan. 1986.
- [5] H. L. Abdel-Malek, A. S. O. Hassan, and M. H. Bakr, "A boundary gradient search technique and its application in design centering," *IEEE Trans. Comput.-Aided Design Integr. Circuits Syst.*, vol. 18, no. 11, pp. 1654–1661, Nov. 1999.
- [6] G. Scotti, P. Tommasino, and A. Trifiletti, "MMIC yield optimization by design centering and off-chip controllers," *IET Proc. Circuits, Devices, Syst.*, vol. 152, no. 1, pp. 54–60, Feb. 2005.
- [7] J. W. Bandler and S. H. Chen, "Circuit optimization: The state of the art," *IEEE Trans. Microw. Theory Techn.*, vol. 36, no. 2, pp. 424–443, Feb. 1988.
- [8] R. Biernacki, S. Chen, G. Estep, J. Rousset, and J. Sifri, "Statistical analysis and yield optimization in practical RF and microwave systems," in *IEEE MTT-S Int. Microw. Symp. Dig.*, Montreal, QC, Canada, Jun. 2012, pp. 1–3.
- [9] J. F. Swidzinski and K. Chang, "Nonlinear statistical modeling and yield estimation technique for use in Monte Carlo simulations," *IEEE Trans. Microw. Theory Techn.*, vol. 48, no. 12, pp. 2316–2324, Dec. 2000.
- [10] E. Matoglu, N. Pham, D. De Araujo, M. Cases, and M. Swaminathan, "Statistical signal integrity analysis and diagnosis methodology for high-speed systems," *IEEE Trans. Adv. Packag.*, vol. 27, no. 4, pp. 611–629, Nov. 2004.
- [11] E. Felt, S. Zanella, C. Guardiani, and A. Sangiovanni-Vincentelli, "Hierarchical statistical characterization of mixed-signal circuits using behavioral modeling," in *Proc. Int. Comput.-Aided Design Conf.*, San Jose, CA, USA, Nov. 1996, pp. 374–380.
- [12] M. Sengupta, S. Saxena, L. Daldoss, G. Kramer, S. Minehane, and J. Cheng, "Application-specific worst case corners using response surfaces and statistical models," *IEEE Trans. Comput.-Aided Design Integr. Circuits Syst.*, vol. 24, no. 9, pp. 1372–1380, Sep. 2005.
- [13] I. S. Stievano, P. Manfredi, and F. G. Canavero, "Parameters variability effects on multiconductor interconnects via hermite polynomial chaos," *IEEE Trans. Compon., Packag., Manuf. Technol.*, vol. 1, no. 8, pp. 1234–1239, Aug. 2011.
- [14] J. S. Ochoa and A. C. Cangellaris, "Random-space dimensionality reduction for expedient yield estimation of passive microwave structures," *IEEE Trans. Microw. Theory Techn.*, vol. 61, no. 12, pp. 4313–4321, Dec. 2013.
- [15] I. Jolliffe, *Principal Component Analysis*. New York, NY, USA: Wiley, 2005.
- [16] S. Koziel, J. Bandler, A. Mohamed, and K. Madsen, "Enhanced surrogate models for statistical design exploiting space mapping technology," in *IEEE MTT-S Int. Microw. Symp. Dig.*, Long Beach, CA, USA, Jun. 2005, pp. 1–4.
- [17] H. L. Abdel-Malek, A. S. O. Hassan, E. A. Soliman, and S. A. Dakroury, "The ellipsoidal technique for design centering of microwave circuits exploiting space-mapping interpolating surrogates," *IEEE Trans. Microw. Theory Techn.*, vol. 54, no. 10, pp. 3731–3738, Oct. 2006.
- [18] J. W. Bandler, J. E. Rayas-Sánchez, and Q.-J. Zhang, "Yield-driven electromagnetic optimization via space mapping-based neuromodels," *Int. J. RF Microw. Comput.-Aided Eng.*, vol. 12, no. 1, pp. 79–89, 2002.
- [19] J. E. Rayas-Sánchez and V. Gutierrez-Ayala, "EM-based Monte Carlo analysis and yield prediction of microwave circuits using linear-input neural-output space mapping," *IEEE Trans. Microw. Theory Techn.*, vol. 54, no. 12, pp. 4528–4537, Dec. 2006.
- [20] S. Koziel and J. W. Bandler, "Feature-based statistical analysis for rapid yield estimation of microwave structures," in *IEEE MTT-S Int. Microw. Symp. Dig.*, Tampa, FL, USA, 2014.
- [21] S. Koziel and S. Szczepanski, "Accurate modeling of microwave structures using shape-preserving response prediction," *IET Microw., Antennas, Propag.*, vol. 5, no. 9, pp. 1116–1122, Jun. 2011.
- [22] S. Koziel, "Accurate low-cost microwave component models using shape-preserving response prediction," *Int. J. Numer. Modeling*, vol. 25, no. 2, pp. 152–162, 2012.
- [23] F. Ferranti, D. Deschrijver, L. Knockaert, and T. Dhaene, "Hybrid algorithm for compact and stable macromodelling of parameterized frequency responses," *Electron. Lett.*, vol. 45, no. 10, pp. 493–495, Oct. 2009.
- [24] F. Ferranti, L. Knockaert, and T. Dhaene, "Passivity-preserving parametric macromodelling by means of scaled and shifted state-space systems," *IEEE Trans. Microw. Theory Techn.*, vol. 59, no. 10, pp. 2394–2403, Oct. 2011.
- [25] P. S. Sumant, H. Wu, A. C. Cangellaris, and N. R. Aluru, "A sparse grid based collocation method for model order reduction of finite element approximations of passive electromagnetic devices under uncertainty," *IEEE MTT-S Int. Microw. Symp. Dig.*, pp. 1652–1655, 2010.
- [26] P. S. Sumant, H. Wu, A. C. Cangellaris, and N. R. Aluru, "Reduced-order models of finite element approximations of electromagnetic devices exhibiting statistical variability," *IEEE Trans. Antennas Propag.*, vol. 60, no. 1, pp. 301–309, Jan. 2012.
- [27] W. Hauth, R. Keller, U. Papziner, R. Ihmels, T. Sieverding, and F. Arndt, "Rigorous CAD of multipost coupled rectangular waveguide components," in *Proc. 23rd Eur. Microw. Conf.*, Madrid, Spain, Sep. 1993, pp. 611–614.
- [28] CST Microwave Studio. ver. 2013, CST AG, Darmstadt, Germany, 2013.
- [29] A. Mediavilla, A. Tazon, J. A. Pereda, M. Lazaro, C. Pantaleon, and I. Santamaria, "High speed analysis and optimization of waveguide bandpass filter structures using simple neural architectures," *Microw. J.*, vol. 44, no. 6, pp. 86–98, Jun. 2001.
- [30] D. Brady, "The design, fabrication and measurement of microstrip filter and coupler circuits," *High Freq. Electron.*, vol. 1, no. 1, pp. 22–30, Jul. 2002.
- [31] "FEKO User's Manual Suite 6.0," EM Softw. Syst. S.A. (Pty) Ltd., Stellenbosch, South Africa, 2011.
- [32] S. Koziel, "Computationally efficient multi-fidelity multi-grid design optimization of microwave structures," *Appl. Comput. Electromagn. Soc. J.*, vol. 25, no. 7, pp. 578–586, 2010.
- [33] S. Koziel, X. S. Yang, and Q. J. Zhang, *Simulation-driven Design Optimization and Modeling for Microwave Engineering*. London, U.K.: Imperial College Press, 2013.



Slawomir Koziel (M'03–SM'07) received the M.Sc. and Ph.D. degrees in electronic engineering from Gdansk University of Technology, Gdansk, Poland, in 1995 and 2000, respectively, and the M.Sc. degree in theoretical physics, M.Sc. degree in mathematics, and Ph.D. degree in mathematics from the University of Gdansk, Gdansk, Poland, in 2000, 2002, and 2003, respectively.

He is currently a Professor with the School of Science and Engineering, Reykjavik University, Reykjavik, Iceland. His research interests include computer-aided design (CAD) and modeling of microwave circuits, simulation-driven design, surrogate-based optimization, space mapping, circuit theory, analog signal processing, evolutionary computation, and numerical analysis.



John W. Bandler (S'66–M'66–SM'74–F'78–LF'06) studied at Imperial College, London, U.K. He received the B.Sc. (Eng.), Ph.D., and D.Sc. (Eng.) degrees from the University of London, London, U.K., in 1963, 1967, and 1976, respectively.

In 1969, he joined McMaster University, Hamilton, ON, Canada. He is currently a Professor Emeritus. In 1983, he founded Optimization Systems Associates Inc. and sold it to Hewlett-Packard in 1997. He is President of Bandler Corporation,

Dundas, ON, Canada.

Dr. Bandler is a Fellow of several societies, including the Royal Society of Canada and the Canadian Academy of Engineering. He was the recipient of the 2004 IEEE Microwave Theory and Techniques Society (IEEE MTT-S) Microwave Application Award, the 2012 IEEE Canada McNaughton Gold Medal, the 2012 Queen Elizabeth II Diamond Jubilee Medal, the 2013 IEEE MTT-S Microwave Career Award, and the 2014 McMaster University Faculty of Engineering Research Achievement Award.