

A. Miszczyk <sup>1</sup>, Dr.,  
K. Darowicki <sup>2</sup>, Prof. Dr.  
(GUT, Gdansk, Poland,  
<sup>1</sup> andrzej.miszczyk@pg.edu.pl,  
<sup>2</sup> kazimierz.darowicki@pg.edu.pl)

## **EVALUATION OF ORGANIC COATING SYSTEMS FOR CORROSION PROTECTION OF INDUSTRIAL EQUIPMENT USING IMPEDANCE SPECTROSCOPY**

The high economic impact of corrosion can be reduced by enhanced corrosion management and prevention based on appropriate means. This applies in particular to the protection of structures with organic protective coatings. Steel is subject to corrosion that reduces its service life and leads to destruction in most severe cases. The application of paints to metallic objects for corrosion control has been known for a long time and is nowadays the most popular technology of metal protection. Paint coatings provide the most widely used industrial corrosion protection but proper operation of industrial devices in harsh corrosive environments requires the application of coating systems characterized by very good anticorrosion performance. However, which coating is the best? There are many manufacturers and protective systems on the market and usually each manufacturer claims that his system is the best. How to choose the best indeed?

Short-term test methods in cabinets do not reflect the specific industrial conditions [1]. Natural methods of exposure are long-lasting [1, 2]. We propose a simple method of eliminating the disadvantages of both methods using impedance spectroscopy and pull-of test [3]. This approach utilizes the ability to detect microscopic degradation symptoms after a short-term exposure in the natural desired industrial environment.

There are essentially three important mechanisms by which organic coatings systems protect against corrosion:

- barrier mechanism – consists in blocking up diffusion of corrosive agents, like water and oxygen, and corrosion stimulants like  $\text{Cl}^-$ ,  $\text{SO}_4^{2-}$ ,
- adhesional mechanism – as long as adhesion of the basecoat to the metal surface is unchanged no corrosion can take place under coating,
- electrochemical mechanism – is generally connected with the presence of active anticorrosive pigments, which are added to the basecoat of the system. At present, the role of this mechanism is reduced. Due to the toxic and carcinogenic properties, highly effective pigments can no longer be

used for corrosion protection. Hence, the first two mechanisms will be taken into account.

An evaluation of these mechanisms has been conducted as a way to evaluate and choose the best systems in specific corrosive industrial environments. This has been proven in the conditions of a mining and processing company at the division of copper ore enrichment. Coating systems samples of various manufacturers were exposed to natural conditions of flotation and ore enrichment facility for half a year. After this period the samples were tested by means of impedance spectroscopy to obtain coating resistance [4, 5] (Fig. 1) (the barrier properties) and measurements of adhesion using pull-off method (the adhesional mechanism).

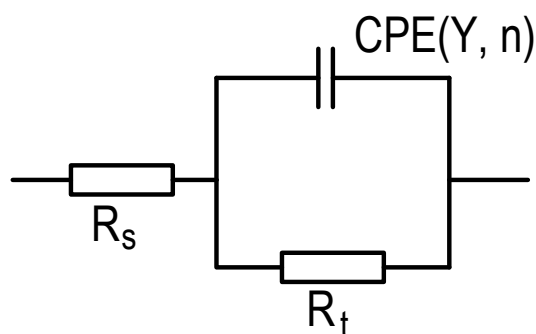

Fig. 1. Equivalent circuit used to fit the impedance spectra obtained after a half year of exposure in harsh environment of flotation and ore enrichment facility.  $R_t$  – coating resistance, CPE - Constant Phase Element describing capacitive properties of the coating,  $R_s$  – resistance of electrolyte.

Two basic aspects of coating protection: the barrier and adhesive mechanisms are characterized by these means. The results obtained are plotted in Fig. 2. Based on this Figure, it is possible to designate a group of the best, medium and the worst coatings under the circumstances of exposure. High coating resistance (barrier) and high adhesion strength characterized the best systems.

High-performance coatings must meet specific performance requirements as well as environmental regulations. Recently, constantly increasing requirements about the anti-corrosion coatings combined with cost and environmental awareness make the need for smart coating selection for corrosion protection of industrial equipment and structures.

A new approach to select protective systems for heavy, specific industrial environments has been proposed. To achieve this aim it uses

evaluation of barrier and adhesional aspects of coating protection after short natural exposure.

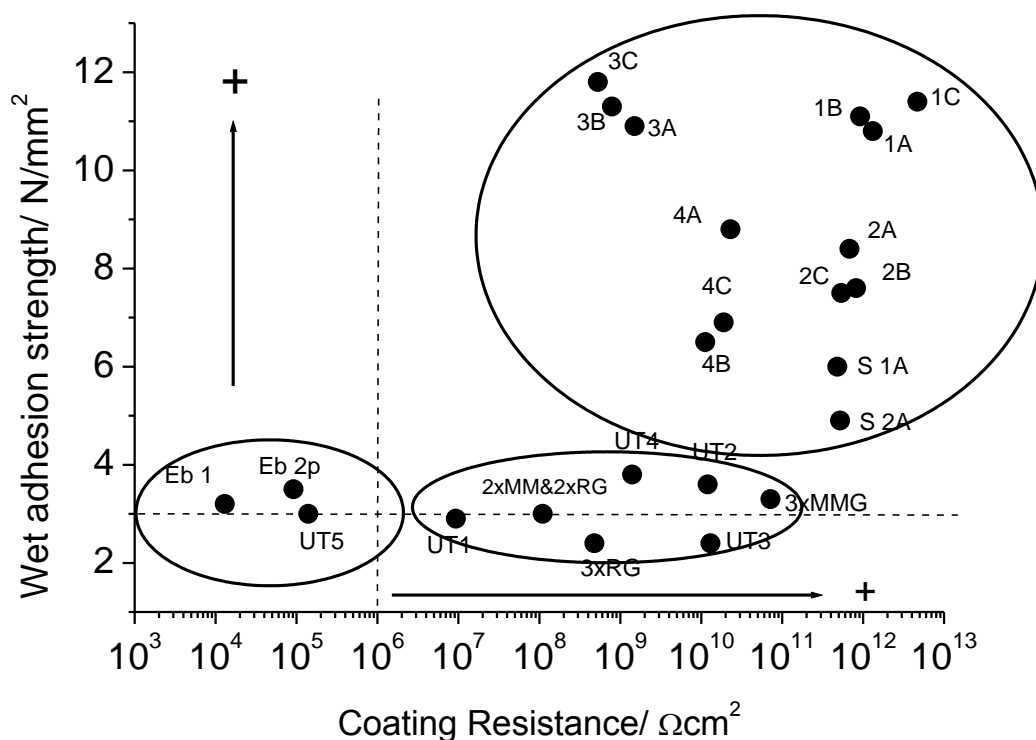

Fig. 2. Evaluation of protective properties of coatings samples on the basis of the resistance and adhesion of the coating to the substrate. Top coatings – the biggest ellipse.

#### REFERENCES

1. Journal Paper: Jacques L.F.E. Accelerated and outdoor/natural exposure testing of coatings // Prog. Polym. Sci. – 2000. – V. 25, – P. 1337–1362.
2. Journal Paper: Roselli S.N., Romagnoli R., Deyá C., The anti-corrosion performance of water-borne paints in long term tests // Prog.Org. Coat. – 2017 - V. 109, iss. 8 – P. 172-178.
3. Standard: EN ISO 4624:2016 Paints and varnishes -- Pull-off test for adhesion.
4. Journal Paper: Miszczyk A., Darowicki K. Multivariate analysis of impedance data obtained for coating systems of varying thickness applied on steel // Prog. Org. Coat. – 2014. – V. 77, – iss. 12, – P. 2000-2006.
5. Journal Paper: Miszczyk A., Darowicki K. Determination of time dependence of coated metal electrical and electrochemical parameters during exposure using principal component analysis // Prog. Org. Coat. – 2014. – V. 77 – iss. 12, – P. 2000-2006.