

RESEARCH ARTICLE | APRIL 27 2018

Magnetoacoustic heating in a quasi-isentropic magnetic gas

Anna Perelomova 



Phys. Plasmas 25, 042116 (2018)

<https://doi.org/10.1063/1.5025030>



View
Online



Export
Citation

CrossMark

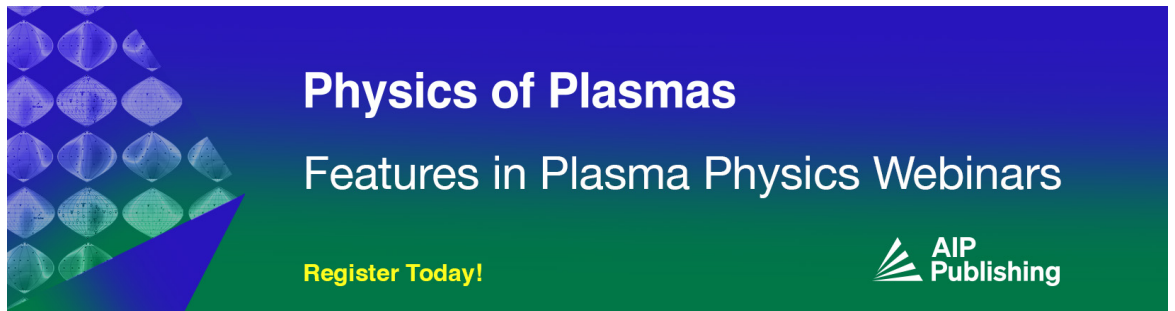

Physics of Plasmas
Features in Plasma Physics Webinars

Register Today!



Magnetoacoustic heating in a quasi-isentropic magnetic gas

Anna Perelomova^{a)}

Faculty of Applied Physics and Mathematics, Gdansk University of Technology, ul. Narutowicza 11/12, 80-233 Gdansk, Poland

(Received 6 February 2018; accepted 8 April 2018; published online 27 April 2018)

The nonlinear heating of a plasma which associates with the transfer of energy of magnetoacoustic waves into that of the entropy mode, is analytically studied. A plasma is uniform and motionless at equilibrium. Perturbations in a plasma are described by a system of ideal magnetohydrodynamic equations. The equilibrium straight magnetic strength and the wave vector form a constant angle which varies from 0 to $\pi/2$. There exist four magnetosound branches (two slow and two fast) which differ by the speed and direction of propagation in this geometry. Various cases of a nonlinear flow take place due to the kind of external source of energy. This may make plasma isentropically or/and thermally unstable. We consider magnetoacoustic heating which is excited by any one of the magnetosound perturbations in the different cases of a flow. The nonlinear instantaneous equations, which describe the dynamics of the entropy mode in the field of intense magnetoacoustic perturbations, are analytically derived and discussed in regard to some physically meaningful cases. We use special projecting in order to derive weakly nonlinear evolutionary equations. *Published by AIP Publishing.* <https://doi.org/10.1063/1.5025030>

I. INTRODUCTION

Perturbations of hydrodynamical variables in a plasma are of great importance in astrophysical and technical applications. Among all variety of perturbations, special interest is paid to wave processes since they may transfer momentum and energy at large distances. The peculiarities of the wave processes are of the crucial importance. In all open fluid's flows, including flows of a plasma, waves may enhance in the course of propagation.¹⁻³ That occurs due to some kind of heating-cooling function which consists of inflow of energy and radiative losses, in the case of isentropic instability of a flow.⁴⁻⁶ Nonlinear phenomena may prevent enlargement in magnitudes of perturbations. Nonlinear attenuation at the fronts of waves with discontinuities makes their magnitude to decrease. The mechanical attenuation and thermal conduction enhance nonlinear damping. Discontinuities are usually resolved in reality by diffusive effects that become important on smaller length-scales. In the case of isentropic instability, wave perturbations enlarge but may be damped by all kinds of attenuation. Stable waveforms, that is, auto-waves, may form. They have been predicted in other wave processes in open systems which are described by the similar evolution equations.^{7,8} Independently on isentropic stability or instability, an open system may be unstable thermally. That means that the perturbations specifying the entropy mode, enlarge with time. In general, perturbations in a plasma consist of these belonging to wave processes and to the non-wave ones, such as vorticity and entropy modes. Perturbations of infinitely small magnitudes evolve independently, but disturbances of finite magnitudes do interact in nonlinear flows. The wave perturbations undergo nonlinear distortions themselves, they may interact with other wave processes, and they may give rise to the non-wave modes.⁹⁻¹¹

The starting point is the system of ideal MHD (magnetohydrodynamic) equations which include the equation of state for an ideal gas in a flow with external inflow (or outflow) of energy. We should discuss briefly the validity of the MHD equations. MHD equations impose that temporal and spatial scales of a flow must be much larger than gyro-kinetic scales. Ideal magnetohydrodynamics is the basic single-fluid model which deals with macroscopic equilibrium quantities of magnetized plasma. The model is valid for the Maxwellian distribution function for particles and equal temperatures of electrons and ions. The MHD system ignores relativity, quantum mechanics, and displacement current in the Ampere's law.^{12,13} Ideal magnetohydrodynamics is a reasonably good approximation in most flows of astrophysical plasmas. The solar atmosphere, Earth's magnetosphere, and neutron star magnetospheres belong to systems that are described reasonably well by MHD equations. They have limited applicability in the problems which relate to kinetic effects, magnetic reconnection, some laboratory plasmas, weakly ionized plasmas, solar photosphere and chromosphere, coronal loops, Earth's ionosphere, cosmic rays, and molecular clouds. The equation of state for an ideal gas is almost always used in astrophysical applications with the exception of planetary and stellar interiors, that is, in applications dealing with dilute (i.e., weakly coupled) plasmas. Gases in thermonuclear reactors, the solar corona, the solar atmosphere, and the interstellar gas are examples of weakly coupled plasmas. We consider phenomena which associate with energy balance in an open flow of a plasma. As for the damping due to mechanical viscosity and thermal conduction, they may be readily involved into consideration. The impacts of these phenomena taken alone are well-understood. The damping phenomena may be included as corrections to the results.^{14,15}

The general nonlinear dynamics of perturbations in a plasma is not far well studied in view of complexity of the

^{a)}anna.perelomova@pg.edu.pl

MHD system of equations which imposes coexistence of slow, fast sound modes, and Alfvén modes, along with the non-wave modes. A flow of magnetic gas depends strongly on the geometry of a flow, features of magnetic field, and energy balance. The fast mode is an acoustic wave in which both magnetic and hydrodynamic pressure contribute. The slow mode is also an acoustic longitudinal wave. It is strongly guided by the magnetic field. The Alfvén modes have a counterpart in waves in elastic strings propagating due to magnetic tension. Nonlinear evolution of individual wave MHD perturbations is well understood. The first particular cases which were studied concern planar flows along and across the straight magnetic field.^{16–18} Nakariakov and co-authors in Ref. 19 analysed the planar propagation of various MHD wave perturbations for arbitrary angle between the straight magnetic field and the wave vector. They derived a weakly nonlinear evolutionary equation for individual slow and fast acoustic mode in an open plasma. The conclusion about the possibility of self-organization of MHD waves into stable shock autowaves was made by Chin and co-authors of Ref. 15. The conclusions concern progressive perturbations without taking into account the transfer of wave energy and momentum into that of non-wave modes. This nonlinear transfer is of interest from the two points of view: distortions of the wave itself and the new equilibrium thermodynamic parameters or bulk flows which form the new background of wave's propagation. In particular, thermal inhomogeneities and vortices may in turn have an impact on wave processes. If conditions of ideal magnetohydrodynamics are valid for description of wave perturbations, they are satisfied a fortiori for the entropy perturbations which are much slower and long-scale comparatively to magnetic sound which induces them.

The subject of this study is the nonlinear generation of the entropy mode in the field of individual slow and fast magneto-sound perturbations. In the description of nonlinear phenomena responsible for the interaction between different modes, we face with mathematical difficulties much serious as compared to the case of nonlinear distortions of individual wave modes. The analytical method of the study is the projecting technique, which has been exploited by the author in many problems of fluid flows.^{14,20,21} Briefly, it allows to derive coupling nonlinear equations for interacting modes in weakly nonlinear flows. The initial point is a system of conservative equations which describes the evolution of perturbations of infinitely small magnitudes. The projecting operators are established. The number of projectors equals the number of independent modes in a flow. The projectors decompose corresponding specific perturbation from the total vector of perturbations. They decompose also evolution equations for the individual modes when applied at the system of conservation equations in the differential form. The projecting allows deriving a system of equations for interacting modes, if we apply a projector at the system of MHD equations which includes nonlinear terms. As usual, quadratic nonlinear terms are of major importance in the weakly nonlinear flows. They represent the products of different specific perturbations. The nonlinear parts of equations are valid for any composition of the total perturbation but may be considerably simplified if one mode is dominative. In this particular case, all cross products which include other specific

perturbations, are small. Only dominative products may be considered in the leading order. Hence, the linear dynamic equation for a secondary mode is enriched by means of projecting with dominative nonlinear terms responsible for the nonlinear excitation. The projecting points a way to derive evolutionary equations with any desired accuracy.

In the context of nonlinear acoustics, sound is dominative. The problem is fairly complex in magnetoacoustics where fast and slow magnetosound modes coexist, and they strongly vary in dependence on the angle between the straight magnetic field and the wave vector. In particular, projecting results in equations of scattering of sound by sound and sound on thermal inhomogeneities which associate with the entropy mode. We consider instantaneous excitation of the entropy perturbations in the field of intense magnetic sound. Only one wave mode is supposed to be dominative for simplicity. Nonlinear dynamic equations, which are derived in this study, are approximate. They include only quadratic nonlinear terms, that is, these proportional to the squared Mach number, M^2 . Nonlinear phenomena may occur unusually in the adiabatically or thermally unstable flows in a plasma. Acoustic heating in all acoustically active media are unusual independently on the physical reason for acoustical activity.^{7,8} The reason for nonlinear interaction of modes is irreversible transfer of energy and momentum, along with external inflow or outflow of energy, which disturbs the adiabaticity of a flow. Following Nakariakov and co-authors, we consider some generic heating-cooling function. It determines whether a flow is adiabatically or thermally stable. The effects of plasma's boundaries are not considered.

II. MODES IN THE LINEAR MHD FLOW

In the ideal MHD approximation, we consider a fluid as a perfect electrical conductor. We remind the full set of ideal MHD equations which includes the continuity equation, the momentum equation, the energy balance equation, and completing electrodynamic equations

$$\begin{aligned} \frac{\partial \rho}{\partial t} + \vec{\nabla} \cdot (\rho \vec{v}) &= 0, \\ \rho \frac{D\vec{v}}{Dt} &= -\vec{\nabla} p + \mu_0 (\vec{\nabla} \times \vec{B}) \times \vec{B}, \\ \frac{Dp}{Dt} - \gamma \frac{p}{\rho} \frac{D\rho}{Dt} &= (\gamma - 1)L(p, \rho), \\ \frac{\partial \vec{B}}{\partial t} &= \vec{\nabla} \times (\vec{v} \times \vec{B}), \\ \vec{\nabla} \cdot \vec{B} &= 0, \end{aligned} \quad (2.1)$$

where p , ρ , \vec{v} , \vec{B} are hydrostatic pressure and density of a plasma, its velocity, the magnetic field strength, and μ_0 is the permeability of free space. The fourth equation from the set is the ideal induction equation, and the fifth one is the Maxwell's equation ensuring the solenoidal character of \vec{B} . The heating-cooling function $L(p, \rho)$ may disturb the isentropy of wave perturbations in a plasma.¹⁹ The third equation in the set (2.1) is valid for an ideal gas with the ratio of specific heats under constant pressure and constant density γ , $\gamma = C_P/C_V$.



We consider the same geometry of a planar flow as in Ref. 19. The equilibrium magnetic strength \vec{B}_0 forms a constant angle θ ($0 \leq \theta \leq \pi/2$) with the positive direction of axis z , and its y -component is zero, so as

$$B_{0,x} = B_0 \sin(\theta), \quad B_{0,z} = B_0 \cos(\theta), \quad B_{0,y} = 0.$$

Axis z points the direction of wave propagation. Figure 1 recalls the geometry of a planar flow.

All thermodynamic quantities are expanded in the vicinity of the equilibrium state as $f(z, t) = f_0 + f'(z, t)$. We

consider initially homogeneous stationary plasma with zero bulk flows, so that $\vec{v}_0 = \vec{0}$. Primes by perturbations of components of velocity and magnetic strength are omitted everywhere ahead in the text.

System (2.1) displays the essential nonlinearity of MHD. Along with purely hydrodynamic nonlinearity, which is mainly responsible for the complexity of fluid dynamics, other nonlinear terms are of importance. The leading-order equations which include, among linear, only quadratic nonlinear terms, follow from Eqs. (2.1)

$$\begin{aligned} \frac{\partial \rho'}{\partial t} + \rho_0 \frac{\partial v_z}{\partial z} &= -\rho' \frac{\partial v_z}{\partial z} - v' \frac{\partial \rho'}{\partial z}, \\ \frac{\partial v_x}{\partial t} - \frac{B_{0,z}}{\rho_0 \mu_0} \frac{\partial B_x}{\partial z} &= -v_z \frac{\partial v_x}{\partial z} - \frac{B_{0,z}}{\rho_0 \mu_0} \rho' \frac{\partial B_x}{\partial z}, \\ \frac{\partial v_y}{\partial t} - \frac{B_{0,z}}{\rho_0 \mu_0} \frac{\partial B_y}{\partial z} &= -v_z \frac{\partial v_y}{\partial z} - \frac{B_{0,z}}{\rho_0 \mu_0} \rho' \frac{\partial B_y}{\partial z}, \\ \frac{\partial v_z}{\partial t} + \frac{1}{\rho_0} \frac{\partial p'}{\partial z} - \frac{B_{0,x}}{\rho_0 \mu_0} \frac{\partial B_x}{\partial z} &= -\frac{\rho'}{\rho_0} \frac{\partial p'}{\partial z} - \frac{B_{0,z}}{\rho_0 \mu_0} \rho' \frac{\partial B_x}{\partial z} - \frac{1}{\rho_0} \frac{\partial}{\partial z} \left(\frac{B_x^2 + B_y^2}{2\mu_0} \right) - v_z \frac{\partial v_z}{\partial z}, \\ \frac{\partial p'}{\partial t} + c^2 \rho_0 \frac{\partial v_z}{\partial x} - (\gamma - 1)(L_p p' + L_\rho \rho') &= (\gamma - 1)(0.5L_{pp} p'^2 + 0.5L_{\rho\rho} \rho'^2 + L_{p\rho} p' \rho') - \gamma p' \frac{\partial v_z}{\partial z} - v_z \frac{\partial p'}{\partial z}, \\ \frac{\partial B_x}{\partial t} + \frac{\partial}{\partial z} (B_{0,x} v_z - B_{0,z} v_x) &= -B_x \frac{\partial v_z}{\partial z} - v_z \frac{\partial B_x}{\partial z}, \\ \frac{\partial B_y}{\partial t} - \frac{\partial}{\partial z} (B_{0,z} v_y) &= -B_y \frac{\partial v_z}{\partial z} - v_z \frac{\partial B_y}{\partial z}, \end{aligned} \tag{2.2}$$

where

$$\begin{aligned} L_p &= \frac{\partial L}{\partial p}, \quad L_\rho = \frac{\partial L}{\partial \rho}, \quad L_{pp} = \frac{\partial^2 L}{\partial p^2}, \quad L_{\rho\rho} = \frac{\partial^2 L}{\partial \rho^2}, \\ L_{p\rho} &= \frac{\partial^2 L}{\partial p \partial \rho} \end{aligned}$$

are corresponding partial derivatives of the heating-cooling function $L(p, \rho)$ with respect to its variables evaluated at the equilibrium state (p_0, ρ_0) . Equations (2.2) is an initial point

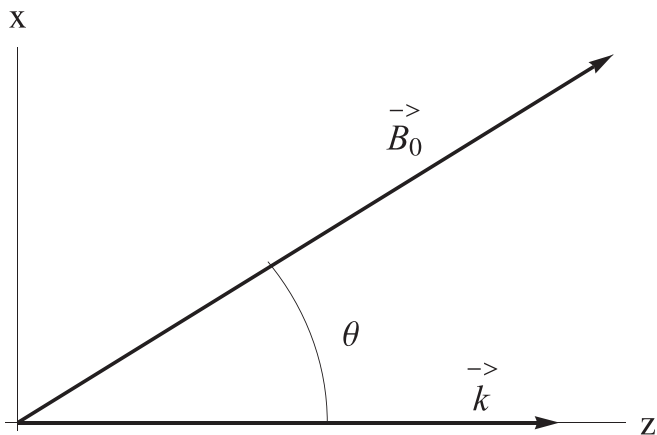

FIG. 1. The geometry of a planar flow. \vec{B}_0 is the equilibrium magnetic strength, and \vec{k} denotes the wave vector.

for further evaluations. The dispersion relations follow from the linearized equations (2.2). We look for solutions of the linearized equations in the form of a sum of planar waves proportional to $\exp(i\omega(k_z)t - ik_z z)$, where k_z designates the wave number, so as

$$f'(z, t) = \int_{-\infty}^{\infty} \tilde{f}(k_z) \exp(i\omega(k_z)t - ik_z z) dk_z.$$

The dispersion relations reflect the solvability of the linearized version of Eqs. (2.1)

$$\begin{aligned} \omega_{1,2} &= \pm C_{A,z} k_z, \quad \omega_j = C_j k_z + i \frac{S_j}{c_0^2} (c_0^2 L_p + L_\rho), \\ \omega_7 &= \frac{i(\gamma - 1)L_\rho}{c_0^2}, \end{aligned} \tag{2.3}$$

where $j = 3, \dots, 6$, C_j is one from four roots of the equation

$$\begin{aligned} C_j^4 - C_j^2(c_0^2 + C_A^2) + c_0^2 C_{A,z}^2 &= 0, \\ C_A &= \frac{B_0}{\sqrt{\mu_0 \rho_0}}, \quad c_0 = \sqrt{\frac{\gamma p_0}{\rho_0}} \end{aligned} \tag{2.4}$$

designate the Alfvén speed and the acoustic speed in unmagnetized gas in equilibrium, and

$$S_j = -\frac{C_j^2(C_j^2 - C_A^2)(\gamma - 1)}{2(C_j^4 - c_0^2 C_{A,z}^2)}, \quad C_{A,z} = C_A \cos(\theta).$$

The first two roots ω_1, ω_2 specify the Alfvén waves. Perturbations which specify these modes are zero with except for perturbations in transversal magnetic strength and transversal fluid’s velocity which are related as

$$B_{y,1} = \frac{B_0}{C_A} v_{y,1}, \quad B_{y,2} = -\frac{B_0}{C_A} v_{y,2}.$$

The next four roots relate to slow and fast magnetosound waves of different directions of propagation, and the last root ω_7 corresponds to the entropy mode. For any non-zero magnetosound speed C_j , the denominator in the expression for S_j differs from zero

$$\begin{aligned} C_j^2(2C_j^2 - c_0^2 - C_A^2) &= (C_j^4 - c_0^2 C_{A,z}^2) \\ &= \frac{C_j}{2} \prod_{n=3, \dots, 6 \neq j} (C_j - C_n). \end{aligned}$$

Zero C_j is one of the roots of Eq. (2.4) which corresponds to $C_{A,z} = 0$ and slow perturbations. This limiting case does not reflect any wave process. The last seventh mode is not progressive and also does not represent a wave process. The magnetosound modes may not be the wave processes if strongly attenuated. We consider a weak attenuation (or enhancement) during a wave period

$$|C_j|k_z \gg \left| \frac{S_j}{c_0^2} (c_0^2 L_p + L_\rho) \right|.$$

This condition determines actually the domain of magnetosound wave numbers to be considered in the case of slow

and fast magnetosound perturbations. The dispersion relations Eqs. (2.3) and (2.4) have been established by Nakariakov and co-authors.^{15,19} They have been used in the analysis of propagation of individual wave perturbations in a plasma. The conditions of acoustic (isentropic, adiabatic) and thermal instabilities are common in all flows in open systems^{1,2}

$$c_0^2 L_p + L_\rho > 0, \quad L_\rho < 0. \tag{2.5}$$

Magnetosound perturbations of infinitely small magnitude enhance in the course of propagation in the case of isentropic instability. The finite-magnitude perturbations may be suppressed by nonlinear attenuation at the front of a shock wave. Thermal instability means enhancement of perturbations in the entropy mode in a linear flow.

The total disturbances are represented by the sums of perturbations specifying every dispersion relation

$$\begin{aligned} v_x &= \sum_{j=1}^7 v_{x,j}, \quad v_y = \sum_{j=1}^7 v_{y,j}, \quad v_z = \sum_{j=1}^7 v_{z,j}, \quad B_x = \sum_{j=1}^7 B_{x,j}, \\ B_y &= \sum_{j=1}^7 B_{y,j}, \quad p' = \sum_{j=1}^7 p_j, \quad \rho' = \sum_{j=1}^7 \rho_j. \end{aligned}$$

Index j in summation denotes the ordering number of individual modes. Links of perturbations in any individual mode are determined by the corresponding dispersion relation. In particular, four magnetosound branches are established by the links ($j = 3, \dots, 6$)

$$\psi_j = \begin{pmatrix} \rho' \\ v_x \\ v_y \\ v_z \\ p' \\ B_x \\ B_y \end{pmatrix}_j = \begin{pmatrix} \frac{\rho_0}{C_j} - \frac{\rho_0 S_j (c_0^2 L_p + L_\rho)}{C_j^2 c_0^2} \int dz \\ \frac{c_0^2 C_{A,z}}{C_j^2 C_{A,x}} - \frac{C_{A,z}}{C_{A,x}} - \frac{C_{A,z} (c_0^2 L_p + L_\rho) (\gamma - 1 + 2S_j)}{C_j^3 C_{A,x}} \int dz \\ 0 \\ 1 \\ \frac{c_0^2 \rho_0}{C_j} - \frac{(c_0^2 L_p + L_\rho) (\gamma - 1 + S_j)}{C_j^2} \int dz \\ \frac{(C_j^2 - c_0^2) B_0}{C_j C_A C_{A,x}} + \frac{(c_0^2 L_p + L_\rho) (c_0^2 (\gamma - 1) + S_j (C_j^2 + c_0^2)) B_0}{C_j^2 c_0^2 C_A C_{A,x}} \int dz \\ 0 \end{pmatrix} v_{z,j}. \tag{2.6}$$

Four acoustic waves are “p” modes, which rely on compressibility. The upper limit of integration is z , and the lower one depends on the physical context of a flow. The transversal components of velocity and magnetic strength, $v_{x,j}$ and $B_{x,j}$, equal zero if $C_{A,x} = 0$ in any magnetosound mode. This is the case of longitudinal propagation which has a little interest, because this case corresponds to the Alfvén speed of the MHD perturbations or to acoustic speed, $|C_j| = c_0$, when magnetic field does not impact on fluid’s dynamics at all. The following relations specify the entropy mode:

$$\psi_7 = \begin{pmatrix} \rho' \\ v_x \\ v_y \\ v_z \\ p' \\ B_x \\ B_y \end{pmatrix}_7 = \begin{pmatrix} 1 \\ \frac{(\gamma - 1) C_{A,x} L_\rho}{C_{A,z} c_0^2 \rho_0} \int dz \\ 0 \\ \frac{(\gamma - 1) L_\rho}{c_0^2 \rho_0} \int dz \\ 0 \\ 0 \\ 0 \end{pmatrix} \rho_7; \tag{2.7}$$

$v_{x,7} = 0$ if $C_{A,z} = 0$. The projecting rows may be established which distinguish an excess density in the individual modes, except for the two first modes which are isochoric. They follow from the system of algebraic equations:

$$P_j(\rho' \quad v_x \quad v_y \quad v_z \quad p' \quad B_x \quad B_y)^T = \rho_j, \quad j = 3, \dots, 7.$$

The projecting rows onto the Alfvén modes may be readily established by choice as a reference variable B_y or v_y , which are non-zero.

III. EXCITATION OF THE ENTROPY PERTURBATIONS IN THE FIELD OF AN INTENSE MAGNETOSOUND MODE

A. Nonlinear dynamics of an individual magnetoacoustic wave

The dynamic equation for an individual magnetosound wave may be obtained by means of anyone from four magnetoacoustic projecting rows. The projecting row ordered as j ($j = 3, \dots, 6$) reads

$$P_j = \begin{pmatrix} -\frac{(\gamma-1)C_j(C_j^2 - C_A^2)}{2c_0^2(C_j^4 - c_0^2C_{A,z}^2)}L_\rho \int dz \\ -\frac{C_{A,x}C_{A,z}C_j\rho_0}{2(C_j^4 - c_0^2C_{A,z}^2)} - (c_0^2L_p + L_\rho) \frac{(\gamma-1)C_{A,x}C_{A,z}\rho_0}{2c_0^2(C_j^4 - c_0^2C_{A,z}^2)} \int dz \\ 0 \\ \frac{C_j(C_j^2 - C_{A,z}^2)\rho_0}{2(C_j^4 - c_0^2C_{A,z}^2)} + (\gamma-1)(c_0^2L_p + L_\rho)C_j^2 \frac{C_j^4 + (c_0^2 + C_A^2)C_{A,z}^2 - (C_A^2 + 2C_{A,z}^2)C_j^2}{2c_0^2(C_j^4 - c_0^2C_{A,z}^2)^2} \int dz \\ \frac{C_j^2 - C_{A,z}^2}{2(C_j^4 - c_0^2C_{A,z}^2)} + (\gamma-1)L_pC_j^3 \frac{5C_j^4 - 10C_j^2C_A^2 + 3C_A^4 - 2c_0^2(C_j^2 - 2C_A^2)}{4c_0^4(C_j^4 - c_0^2C_{A,z}^2)^2} \int dz \\ + (\gamma-1)L_pC_j^3 \frac{C_j^4 + 2c_0^2C_A^2 - 4C_j^2C_A^2 + C_A^4}{4c_0^2(C_j^4 - c_0^2C_{A,z}^2)^2} \int dz \\ \frac{C_j^2C_{A,x}C_A^2\rho_0}{2B_0C_A(C_j^4 - c_0^2C_{A,z}^2)} - (c_0^2L_p + L_\rho) \frac{(\gamma-1)C_j^3C_{A,x}C_A(2c_0^2 - 3C_j^2 + C_A^2)\rho_0}{4B_0c_0^2(C_j^4 - c_0^2C_{A,z}^2)^2} \int dz \\ 0 \end{pmatrix}^T. \quad (3.1)$$

In the context of nonlinear acoustics, distortions and nonlinear phenomena of intense waves are of the major importance. This means that magnetosound perturbations are much larger than that of other modes, at least in some temporal and spacial domains under consideration. We suppose that only one magnetosound wave is dominative with the linear speed C_j which is arbitrary of four roots of Eq. (2.4). It may correspond to slow or fast wave of any direction of propagation along axis z . The dynamic equation which describes the nonlinear distortion of magnetoacoustic wave is a result of application of the projecting row P_j ($j = 3, \dots, 6$) at the system (2.2). The weakly nonlinear equation which governs the longitudinal component of velocity $v_{z,j}$ in the individual MHD wave mode, takes the form

$$\frac{\partial v_{z,j}}{\partial t} + C_j \frac{\partial v_{z,j}}{\partial z} + D_j C_j v_{z,j} + \varepsilon_j v_{z,j} \frac{\partial v_{z,j}}{\partial z} = 0, \quad (3.2)$$

with

$$D_j = \frac{S_j C_j}{c_0^2} (c_0^2 L_p + L_\rho),$$

$$\varepsilon_j = \left(\frac{(\gamma+1)c_0^2(C_j^2 - C_{A,z}^2)}{2(C_j^4 - c_0^2C_{A,z}^2)} + \frac{3C_j^4 C_{A,x}^2}{2(C_j^2 - C_{A,z}^2)(C_j^4 - c_0^2C_{A,z}^2)} \right).$$

In the absence of magnetic field and deviation from adiabaticity, Eq. (3.2) coincides with the well-known equation for velocity in the progressive Riemann's wave with $D_j = 0$, $C_j = c_0$, $\varepsilon_j = \frac{\gamma+1}{2}$.²² Equation (3.2) does not account for nonlinear interaction between modes but considers nonlinear distortions of the dominative wave itself, that is, nonlinear self-action of a wave. It recalls dynamic equations for perturbations in other media which may be acoustically active due to different reasons.^{7,8} Equation (3.2) for an isentropic flow of an ideal fluid, that is, in the case $D_j = 0$, has been firstly derived and analyzed in the context of propagation of a sawtooth impulse in Ref. 18.

B. Instantaneous magnetosonic heating (cooling)

The projecting row onto an excess density which specifies the entropy mode, takes the form

$$P_7 = \begin{pmatrix} 1 - \frac{(\gamma-1)C_{A,x}\rho_0}{C_{A,z}c_0^4} (c_0^2L_p + L_\rho) \int dz & 0 \\ -\frac{(\gamma-1)\rho_0}{c_0^4} (c_0^2L_p + L_\rho) \int dz & -\frac{1}{c_0^2} & 0 & 0 \end{pmatrix}. \quad (3.3)$$

Application of P_7 at the system (2.2) leads to a weakly nonlinear evolutionary equation which describes dynamics of



excess density which specifies the entropy mode, ρ_7 . Among quadratic nonlinear terms, we will consider only these ones which belong to one from four wave modes. They form the

“force” of magnetoacoustic heating or cooling. As the result of application of P_7 , one arrives at the equation which governs an excess density in the entropy mode

$$\begin{aligned} \frac{\partial \rho_7}{\partial t} + \frac{(\gamma + 1)L_\rho}{c_0^2} \rho_7 = & \frac{(\gamma - 1)\rho_0}{4C^4 c_0^4 C_{A,x}(C^4 - c_0^2 C_{A,z}^2)} \left((3C^8(C_{A,x} + C_{A,z})(c_0^2 L_p + L_\rho) - c_0^6 C_{A,z}^3 (\gamma + 1)(c_0^2 L_p + L_\rho) \right. \\ & - C^4 c_0^2 (C_{A,z}^2 (\gamma + 1)(C_{A,x} + C_{A,z}) + c_0^2 ((4 - \gamma)C_{A,x} + (2\gamma - 7)C_{A,z})) (c_0^2 L_p + L_\rho) \\ & + C^6 c_0^2 (C_{A,z}((\gamma - 8)L_\rho - 2c_0^4 C_{A,x} \rho_0 L_{pp} + C_{A,x}((\gamma - 3)L_\rho - 2\rho_0 L_{\rho\rho})) \\ & + c_0^2 (C_{A,z}(\gamma - 8)L_p - C_{A,x}((\gamma + 1)L_p + 4\rho_0 L_{pp}))) + C^2 c_0^4 C_{A,z} (c_0^4 ((\gamma - 2)L_p + 2C_{A,x} C_{A,z} \rho_0 L_{pp}) \\ & + c_0^2 (2(\gamma + 1)C_{A,z}^2 L_p + (\gamma - 2)L_\rho + C_{A,x} C_{A,z} ((\gamma + 3)L_p + 4\rho_0 L_{pp})) + C_{A,z} (2C_{A,z}(\gamma + 1)L_p \\ & + C_{A,x}((5 - \gamma)L_\rho + 2\rho_0 L_{\rho\rho}))) v_z^2 - 2C^2 c_0^2 C_{A,x} (2\gamma C^4 - C^2 c_0^2 (\gamma - 1) \\ & \left. - (\gamma + 1)c_0^2 C_{A,z}^2)(c_0^2 L_p + L_\rho) \frac{\partial v_z}{\partial z} \int v_z(z, t) dz. \right. \end{aligned} \tag{3.4}$$

The right-hand side of Eq. (3.4) represents the magnetoacoustic force of heating (or cooling), where C is anyone from four solutions to Eq. (2.4). We drop index j by C and v_z for simplicity everywhere ahead in the text. Equation (3.4) includes only instantaneous perturbations. It is valid in description of heating excited by any kind of wave excitation.

C. Magnetoacoustic heating caused by nearly harmonic excitation in the case $L(T)$

Equation (3.4) is much simpler for analysis in the case of harmonic or quasi-harmonic magnetoacoustic perturbations. In the leading order

$$\overline{v_z^2} = -\frac{\partial v_z}{\partial z} \int v_z dz,$$

where the top line denotes the temporal average over period of the magnetoacoustic wave. We consider the case when the heating-cooling function depends exclusively on temperature, $L = L(T)$. Making use of notations, $\frac{dL}{dT} \equiv L_T$, $\frac{d^2 L}{dT^2} \equiv L_{TT}$ and equalities

$$\begin{aligned} L_p &= \frac{L_T}{C_V(\gamma - 1)\rho_0}, \quad L_\rho = -\frac{c_0^2 L_T}{C_V(\gamma - 1)\gamma\rho_0}, \\ L_{pp} &= \frac{L_{TT}}{C_V^2(\gamma - 1)^2\rho_0^2}, \quad L_{p\rho} = -\frac{C_V(\gamma - 1)\gamma L_T + c_0^2 L_{TT}}{C_V^2(\gamma - 1)^2\gamma\rho_0^2}, \\ L_{\rho\rho} &= \frac{c_0^2(2C_V(\gamma - 1)\gamma L_T + c_0^2 L_{TT})}{C_V^2(\gamma - 1)^2\gamma^2\rho_0^2}, \end{aligned} \tag{3.5}$$

where all derivatives are evaluated at the equilibrium temperature, one may readily rearrange Eq. (3.4) into the dynamic equation

$$\begin{aligned} \frac{\partial \rho_7}{\partial t} - \frac{(\gamma + 1)}{C_V(\gamma - 1)\gamma\rho_0} L_T \overline{\rho_7} \equiv F_{ms} = & \frac{(\gamma - 1)L_T}{4\gamma C^4 c_0^2 C_{A,x}(C^4 - c_0^2 C_{A,z}^2)C_V} (3C^8(C_{A,x} + C_{A,z}) - (\gamma + 1)c_0^6 C_{A,z}^3 + C^6 c_0^2 (C_{A,x} \\ & + (\gamma - 8)C_{A,z} + 3\gamma C_{A,x}) + C^2 c_0^4 C_{A,z} ((\gamma - 2)c_0^2 - (C_{A,x} - 2(\gamma + 1)C_{A,z})C_{A,z}) \\ & + C^4 c_0^2 (c_0^2 ((7 - 2\gamma)C_{A,z} - (\gamma + 2)C_{A,x}) - (\gamma + 1)C_{A,z}^2 (C_{A,x} + C_{A,z}))) \overline{v_z^2}. \end{aligned} \tag{3.6}$$

In Eq. (3.6), the second order derivative L_{TT} is omitted. That is valid if $|L_{TT}| \ll \frac{\gamma}{T_0} |L_T|$. Equation (3.6) is still difficult for analysis. Let $v_z^2 = 0.5V_0^2$ in the leading order for approximately harmonic excitation with the amplitude V_0 .

1. Small or large magnetic strengths

We consider weak magnetic fields with

$$\frac{C_A}{c_0} = \sqrt{\frac{2}{\gamma\beta}} \ll 1,$$

where β is plasma’s beta, and the opposite case of strong magnetic strength (this is the case of the solar corona with $\beta = 3.5 \times 10^{-3}$)

$$\frac{c_0}{C_A} = \sqrt{\frac{\gamma\beta}{2}} \ll 1.$$

In the first case, the fast magnetosound propagates with approximate absolute speed

$$|C_{small}| = c_0 + \frac{1 - \cos^2(\theta)}{2c_0} C_A^2,$$

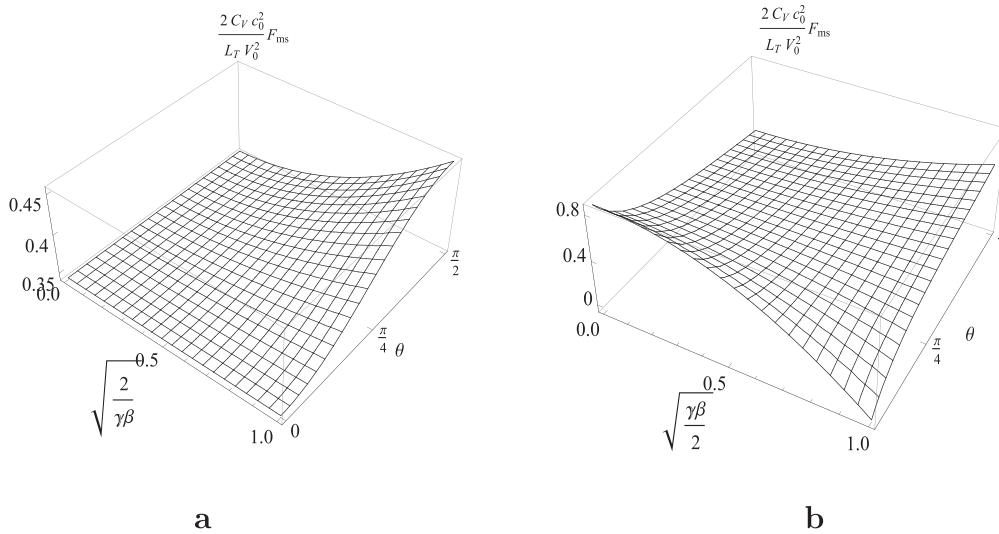

FIG. 2. Dimensionless magnetoacoustic force of heating (cooling) $\frac{2C_V \epsilon_0^2}{L_T V_0^2} F_{ms}$. Cases of small (a) and large (b) magnetic strengths.

and the magnetosonic force of heating is as follows:

$$F_{ms} = \frac{\gamma^2 - 1}{4C_V c_0^2 \gamma} L_T V_0^2 - \frac{(\gamma - 1)(\gamma - 3)(1 - \cos^2(\theta))}{4C_V c_0^2 \gamma^2 \beta} L_T V_0^2. \quad (3.7)$$

In the opposite case of strong magnetic field, the fast magnetoacoustic waves propagate with absolute speed

$$|C_{large}| = C_A + \frac{1 - \cos^2(\theta)}{2C_A} c_0^2.$$

Cases of small and large magnetic strengths (which correspond to small or large $\sqrt{\frac{2}{\gamma\beta}}$) are represented by Figs. 2(a) and 2(b).

The conditions of isentropical and thermal instability differ in general. In the case of L which depends exclusively on temperature, they coincide and read

$$L_T > 0.$$

If a gas is acoustically active, the plasma's background temperature gets smaller. It associates with T_7 which decreases if ρ_7 increases during an isobaric process. Sound enhances in a medium taking energy from the background. Equation

(3.6) is readily integrated for zero initial condition with the result

$$\frac{\overline{\rho_7}}{\rho_7} = \frac{C_V(\gamma - 1)\gamma\rho_0}{(\gamma + 1)L_T} \left(\exp\left(\frac{(\gamma + 1)L_T}{C_V(\gamma - 1)\gamma\rho_0} t\right) - 1 \right) F_{ms}. \quad (3.8)$$

The production of excess temperature associating with the entropy mode may be suppressed by the nonlinear transfer of energy between different modes in dependence on the ratio of their intensity and nonlinear attenuation at the fronts of waves with discontinuities.

2. Nearly perpendicular or parallel orientation of the magnetic strength and the wave vector

The magnetoacoustic force of heating may be simplified in the case of almost perpendicular orientation [this is the case of $\cos(\theta) \approx 0$], and in the limiting case of almost parallel orientation [this is the case of $\sin(\theta) \approx 0$]. In the first case, the fast modes propagate with approximate absolute velocity

$$|C_{perp}| = \sqrt{c_0^2 + C_A^2} - \frac{c_0^2 C_A^2}{2(c_0^2 + C_A^2)^{3/2}} \cos^2(\theta),$$

and the magnetoacoustic force of heating equals

$$F_{ms} = \frac{(\gamma - 1)(6 + \gamma^2\beta(3 + 2.5\beta + 0.5\beta^2)) + \gamma\beta(10 + 4.5\beta + 0.5\beta^2) + \cos(\theta)(6 + \gamma\beta + \gamma^2\beta)}{2\gamma C_V c_0^2 (2 + \gamma\beta)^3} L_T V_0^2. \quad (3.9)$$

In the case of nearly parallel propagation

$$|C_{par}| = c_0^2 + \frac{c_0 C_A^2}{2(c_0^2 + C_A^2)} \sin^2(\theta),$$

and

$$F_{ms} = \frac{(\gamma^2 - 1)}{4\gamma C_V c_0^2} L_T V_0^2 + \frac{(\gamma - 1)(2 + 3\gamma\beta - \gamma(\gamma\beta - 2))}{4\gamma C_V c_0^2 (\gamma\beta - 2)^2} \sin^2(\theta) L_T V_0^2. \quad (3.10)$$

Figure 3 shows the magnetoacoustic forces of heating (cooling), in dependence on the sign of L_T , in two limiting cases of almost parallel or perpendicular orientation of the magnetic strength and the wave vector. Dynamics of an excess density which specifies the entropy mode is given by Eq. (3.8).

IV. CONCLUSION

The main result of this study is the nonlinear instantaneous dynamic equation Eq. (3.4). It describes excitation of

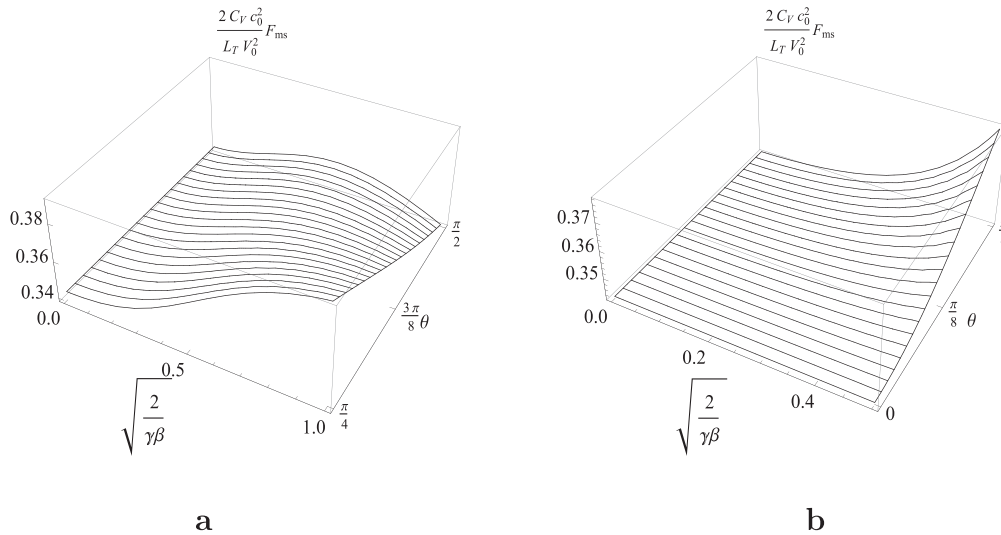

FIG. 3. Dimensionless magnetoacoustic force of heating (cooling) $\frac{2C_V c_0^2}{L_T V_0^2} F_{ms}$ as a function of θ and $\sqrt{\frac{2}{\gamma\beta}}$ in the cases of almost perpendicular (a) and parallel (b) orientation of the magnetic strength and the wave vector.

the excess density which specifies the entropy mode in the field of intense magnetosound waves. Section III C studies the case of excitation if the longitudinal velocity of the MHD wave in a plasma is harmonic. This is the simplest approximation. The exact solution of Eq. (3.2) which is sinusoidal at $z=0$ with frequency Ω , reads

$$v_z = V_0 \exp(-Dz) \times \sum_{n=1}^{\infty} \frac{2J_n(nK(\exp(-Dz) - 1)) \sin(n\Omega(t - z/C))}{nK(\exp(-Dz) - 1)}, \quad (4.1)$$

where $K = -\frac{\varepsilon V_0 \Omega}{DC}$. It is valid before forming of a discontinuity,⁷ that is, if

$$0 < z < -\ln(1 + 1/K)D^{-1}.$$

A discontinuity always forms if $D < 0$ (that is, in the isentropically unstable flow) and never forms in the stable flow if $K \leq -1$. The solution (4.1) introduces dependence of the magnetoacoustic force on z : in all formulas on F_{ms} , in this case, V_0^2 should be replaced by $2V_0^2 \sum_{n=1}^{\infty} \left(\frac{J_n(nK(\exp(-Dz) - 1))}{nK(\exp(-Dz) - 1)} \right)^2$. We consider non-adiabaticity due to the heating-cooling function exclusively, which along with nonlinearity, is a reason for transfer of the wave energy into that of the entropy mode.

Magnetoacoustic heating, in turn, has impact on the character of MHD wave perturbations. Enlargement in equilibrium temperature results in enlargement in c_0 , and hence, in C . In isentropically unstable flow, C gets smaller. *Ceteris paribus*, enlargement in c_0 means enlargement of plasma- β . Magnetosound speed of the fast modes is always larger than that of slow modes at any β and any θ . They are equal only at $\beta = 2/\gamma$, if $\theta = 0$, that is, in the case of parallel propagation. The difference between speeds of fast and slow MHD perturbations constantly enlarges with growth of plasma- β if $\beta > 2/\gamma$. That means that fast and slow modes undergo an additional discrepancy in the isentropically stable plasma due

to magnetoacoustic heating. That may be exploited as an indicator of kind of the external inflow of energy into a plasma, which corresponds to an isentropically stable or unstable flow. Variations in the speed of quick perturbations are the main manifestation of wave's thermal self-action which may occur unusually in the acoustically active media. In particular, thermal lenses in multidimensional flows may lead to focusing and self-focusing of a beam, also anomalous.^{23–25}

The only limitations of this study are

- (1) Validity of ideal MHD equations;
- (2) The planar geometry of a flow with constant equilibrium magnetic strength which forms a constant angle with the wave vector;
- (3) The weak nonlinearity of a flow;
- (4) Weak distortions associating with non-isentropicity of a wave over its characteristic period in the course of propagation.

There is no restriction concerning strength of the magnetic field in this study and hence, the plasma- β . The results may be addressed to various sorts of a plasma: a cold molecular ISM gas ($T < 10^3$ K) or a hot atomic plasma ($T > 10^4$ K) and to different kinds of the function $L(p, \rho)$. The radiation function also contributes in L . Various models of coronal radiative losses and coronal heating are listed in Refs. 4 and 26 and referred therein references. Variations of equilibrium temperature due to magnetoacoustic heating may provide data for analytical predictions of L . The results apply also to pulsed MHD wave perturbations.

The Alfvén modes are not excited by the magnetosound modes, at least, the coupling is very weak: the Alfvén modes are determined exclusively by non-zero v_y and B_y , while the magnetoacoustic mode are specified by non-zero all other field perturbations. That has been pointed by Nakariakov and co-authors in Ref. 19.

¹G. B. Field, "Thermal instability," *Astrophys. J.* **142**, 531–567 (1965).

²E. N. Parker, "Instability of thermal fields," *Astrophys. J.* **117**, 431–436 (1953).

- ³D. I. Zavershinsky, N. E. Molevich, and D. S. Ryashchikov, "Structure of acoustic perturbations in heat-releasing medium," *Procedia Eng.* **106**, 363–367 (2015).
- ⁴J. F. Vesecky, S. K. Antiochos, and J. H. Underwood, "Numerical modeling of quasi-static coronal loops. I - Uniform energy input," *Astrophys. J.* **233**(3), 987–997 (1979).
- ⁵R. B. Dahlburg and J. T. Mariska, "Influence of heating rate on the condensational instability," *Sol. Phys.* **117**(1), 51–56 (1988).
- ⁶M. H. Ibáñez and S. A. Parravano, "On the thermal structure and stability of configurations with heat diffusion and a gain-loss function. 3: Molecular gas," *Astrophys. J.* **424**(2), 763–771 (1994).
- ⁷A. I. Osipov and A. V. Uvarov, "Kinetic and gasdynamic processes in nonequilibrium molecular physics, Sov," *Phys. Usp.* **35**(11), 903–923 (1992).
- ⁸N. E. Molevich, "Sound amplification in inhomogeneous flows of nonequilibrium gas," *Acoust. Phys.* **47**(1), 102–105 (2001).
- ⁹G. Brodin, L. Stenflo, and P. K. Shukla, "Nonlinear interactions between kinetic Alfvén and ion-sound waves," *Sol. Phys.* **236**, 285–291 (2006).
- ¹⁰D. I. Zavershinsky and N. E. Molevich, "Alfvén wave amplification as a result of nonlinear interaction with a magnetoacoustic wave in an acoustically active conducting medium," *Tech. Phys. Lett.* **40**(8), 701–703 (2014).
- ¹¹O. Lyubchik and V. Voitenko, "Nonlocal coupling of kinetic sound waves," *Ann. Geophys.* **32**, 1407–1413 (2014).
- ¹²J. P. Freidberg, *Ideal Magnetohydrodynamics* (Plenum Press, NY, 1987).
- ¹³N. A. Krall and A. W. Trivelpiece, *Principles of Plasma Physics* (McGraw Hill, NY, 1973).
- ¹⁴A. Perelomova, "On the nonlinear effects of magnetoacoustic perturbations in a perfectly conducting viscous and thermo-conducting gas," *Acta Phys. Pol. A* **130**, 727–733 (2016).
- ¹⁵R. Chin, E. Verwichte, G. Rowlands, and V. M. Nakariakov, "Self-organization of magnetoacoustic waves in a thermal unstable environment," *Phys. Plasmas* **17**(32), 032107 (2010).
- ¹⁶N. S. Anderson, "Longitudinal magneto-hydrodynamic waves," *JASA* **25**(3), 529–532 (1953).
- ¹⁷E. A. Ponomarev, "On the propagation of low-frequency oscillations along the magnetic field in a viscous compressible plasma," *Sov. Astron.* **5**(5), 673–677 (1962).
- ¹⁸V. D. Sharma, L. P. Singh, and R. Ram, "The progressive wave approach analyzing the decay of a sawtooth profile in magnetogasdynamics," *Phys. Fluids* **30**(5), 1572–1574 (1987).
- ¹⁹V. M. Nakariakov, C. A. Mendoza-Briceno, and M. H. Ibáñez, "Magnetoacoustic waves of small amplitude in optically thin quasi-isentropic Plasmas," *Astrophys. J.* **528**, 767–775 (2000).
- ²⁰A. Perelomova, "Development of linear projecting in studies of non-linear flow. Acoustic heating induced by non-periodic sound," *Phys. Lett. A* **357**, 42–47 (2006).
- ²¹A. Perelomova, "On the nonlinear distortions of sound and its coupling with other modes in a gaseous plasma with finite electric conductivity in a magnetic field," *Arch. Acoust.* **41**(4), 691–699 (2016).
- ²²O. V. Rudenko and S. I. Soluyan, *Theoretical Foundations of Nonlinear Acoustics* (Plenum, New York, 1977).
- ²³A. Perelomova, "Thermal self-action effects of acoustic beam in a gas with reversible or irreversible chemical reaction," *Acta Acust. Acust.* **99**, 352–358 (2013).
- ²⁴A. Perelomova, "Self-refraction of acoustic pulses with shock fronts in some non-equilibrium media," *Can. J. Phys.* **92**(5), 401–405 (2014).
- ²⁵A. Perelomova, "Thermal self-action effects of acoustic beam in a vibrationally relaxing gas," *Appl. Math. Modell.* **38**, 5684–5691 (2014).
- ²⁶R. Rosner, W. H. Tucker, and G. S. Vaiana, "Dynamics of the quiescent solar corona," *Astrophys. J.* **220**, 643–665 (1978).

