

CONTROL OF THE WAVES IN A TOWING TANK WITH THE USE OF A BLACK-BOX MODEL

Marcin DRZEWIECKI^{1,2}

1. Gdańsk University of Technology Faculty of Electrical and Control Engineering
tel.: +48 662 047 014 e-mail: marcin.drzewiecki@pg.edu.pl
2. Ship Design and Research Centre CTO S.A.
tel.:+48 662 047 014 e-mail: marcin.drzewiecki@cto.gda.pl

Abstract: The paper describes an adaptive control system of the waves, implemented in the Ship Design and Research Centre, CTO S.A. The purpose of generating the waves in the towing tank is the modelling of the environmental conditions during hydrodynamic model tests. The tests are performed on scale models of towed or free running ships, anchored structures like oil rigs or bottom-mounted structures, e.g. wind turbines. In the towing tank of CTO S.A., the waves are generated using a flap-type wavemaker with hydraulic drive. The adaptive control system includes gain scheduling and Black-Box model. It has been developed and implemented using the 32-bit embedded system and computer application (C#.NET). The Black-Box model was proposed as a simple solution allowing compensating the hydromechanical phenomena affecting the generated waves, i.e. disintegration, reflection, damping and nonlinear energy transfer. The solution proved to be sufficient to generate required wave spectra with expected accuracy in a user-friendly manner.

Keywords: adaptive control; Black-Box model; wavemaker.

1. INTRODUCTION

Water waves in the towing tank in Ship Hydromechanic Division of the Ship Design and Research Centre (CTO) S.A. are generated for modelling of the environmental conditions, i.e. ocean waves, in reduced scale. The environmental conditions are modelled in order to evaluate the motion response of ships (Fig. 1), anchored oil rigs etc. as well as to evaluate the wave loads, e.g. on bottom-mounted wind turbines. The laboratory tests at model scale allow determining the properties of full scale objects in order to ensure survivability of the constructions and safety of the crews.



Fig. 1. The model of a ship in towing tank while seakeeping test

The waves are generated in the towing tank in accordance with modelled Sea State *SS* [1]. The *SS*, modelled in a reduced scale, is chosen depending on sea area for which tested object is dedicated. The environmental conditions in scope of waving, depending on *SS*, are presented in Tab. 1. The information given there includes the parameters of the spectrum of the wave to be modelled: significant wave height *H_s* and wave peak period *T_p*. The significant wave height is an average of $\frac{1}{3}$ of highest waves, while the peak period corresponds to maximum of the spectral energy density.

Usually, two kinds of wave spectra are used [2]: Pierson-Moskowitz and JONSWAP. These spectra are idealized approximations of actual wind wave energy spectra corresponding to fully developed seas (Pierson-Moskowitz) and fetch limited seas (JONSWAP). Both of them are calculated according to specified formulas [3] which uses *T_p* and *H_s*.

Table 1. Environmental conditions in scope of waving, depending on sea states in the North Atlantic and North Pacific [1]

SS	North Atlantic		North Pacific	
	<i>H_s</i> m	<i>T_p</i> s	<i>H_s</i> m	<i>T_p</i> s
0-1	0..0.10	-	0..0.10	-
2	0.10..0.50	3.3..12.8	0.10..0.50	3.0..15.0
3	0.50..1.25	5.0..14.8	0.50..1.25	5.2..15.5
4	1.25..2.50	6.1..15.2	1.25..2.50	5.9..15.5
5	2.50..4.00	8.3..15.5	2.50..4.00	7.2..16.5
6	4.00..6.00	9.8..16.2	4.00..6.00	9.3..16.5
7	6.00..9.00	11.8..18.5	6.00..9.00	10.0..17.2
8	9.00..14.00	14.2..18.6	9.00..14.00	13.0..18.4
>8	>14.00	18.0..23.7	>14.00	20

Controlling the waves using proposed Black-Box model – as proven in this paper – is highly efficient, allows saving time while preparing and conducting the model tests, and it provides the required accuracy of modelling of environmental conditions. Finally, it contributes to model testing capability of CTO S.A., enabling the service for the safety of people and constructions.

2. SURVEY OF RELATED WORKS

A wavemaker theory has been established by, among others, Biésel and Suquet [4]. They developed the equations being a linear approximation of the dependence between height of the generated wave and displacement of the paddle for a few types of wavemakers, according to the 1st order wavemaker theory. Thenceforth, higher order nonlinear effects, affecting the generated waves, were the motivation for developing the 2nd order wavemaker theory; it was realized by, among others, Sulisz and Hudspeth [5]. Besides the wave generation, the phenomena accompanying the wave propagation process along a towing tank, i.e. non-linear interactions, disintegration, reflection and damping, affect the modelled waves, as it has been investigated in the CTO S.A. deepwater towing tank [6].

All mentioned phenomena which affect the waves modelled in the towing tank, have to be taken into account in wave modelling process.

3. OBJECTIVES AND SCOPE

The waves are generated in the deepwater towing tank of the following dimensions: length 270 m, width 12 m and depth 6 m, equipped with the wavemaker with single unit paddle and articulation above channel bed, as shown in Fig. 2.

The wavemaker has a hydraulic drive with a double-acting hydraulic cylinder powered by an electric oil pump and controlled using an electrohydraulic servo valve. This configuration allows cascade control – paddle velocity control in the inner loop and paddle position control in the outer loop, where the electrohydraulic servo valve and the hydraulic cylinder are actuators, respectively.

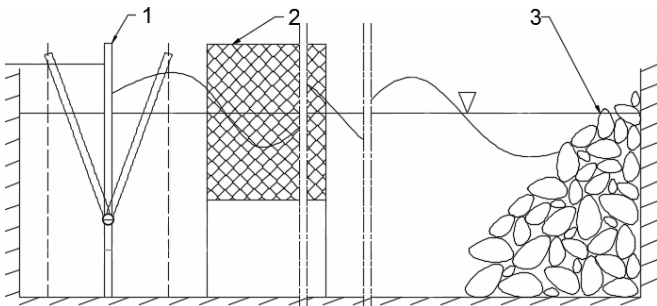

Fig. 2. Longitudinal profile of the towing tank: wavemaker paddle (1), waveguides (2), rock beach (3)

According to the 1st order wavemaker theory, the transfer function hTF between height of the generated wave HW and displacement of the wavemaker paddle $AX2$, can be easily calculated. In fact, the 1st order linear approximation does not take into account nonlinear effects occurring in the wave generation process. Furthermore, even 2nd order theory does not capture all phenomena observed in the towing tank during the wave propagation process. On the other hand, accurate modelling of the waves in a towing tank requires that all the phenomena affecting the modelled waves are taken into account by the control system of the waves.

In the scope of presented work, the possibility of controlling the waves with the use of Black-Box model was investigated; the idea of this model is to achieve required output without going into physics, i.e. complex hydromechanical models of the wave propagation in the towing tank. The research was conducted for the wave energy spectra of the parameters shown in Tab. 2. The range

of analyzed wave height corresponds to actual range of wave height used in seakeeping model tests conducted in the deepwater towing tank.

The main contribution of this paper is to provide the method to simplify the wave modelling process and make it more efficient and more accurate by implementation of the Black-Box model with wave spectrum feedback.

Table 2. Parameters of investigated wave energy spectra: Pierson-Moskowitz and JONSWAP

H_s	T_p
cm	s
10.0	1.667
15.0	2.500
25.0	2.500

4. PROPOSED SOLUTION

The proposed solution for wave control consists in combining the linear control of the paddle position with the adaptive control of the waves using gain scheduling with Black-Box model and wave spectrum feedback. Such an approach is intended to overcome the problem with developing an exact deterministic model of wave generation.

The Black-Box is understood as a model which only takes into account the relationship between the required and realized wave energy spectrum and then returns the required correction function. This approach allows to compensate the effects of hydromechanical phenomena with omission of hydromechanical models, which are complex and often not sufficiently general and robust.

4.1. Modelling

The structural diagram of control system is shown in Fig. 3. It consists of the following blocks: hydromechanic transfer function, developed on the basis of the 1st order wavemaker theory (hTF); electromechanic transfer function between voltage applied to the electrohydraulic servo valve and displacement of the paddle (eTF); proportional gain (P), scheduled according to gain scheduling (GS); PI controllers in a cascade structure: master (mPI) and slave (sPI), which control the paddle velocity $AX1(t)$ and paddle position $AX2(t)$, respectively, using actuators: electrohydraulic servo valve ($I1$) and hydraulic cylinder ($I2$), respectively; Black-Box model implemented to compensate the phenomena which affect the waves along the towing tank (BB). The system operates in a time domain for linear controlling of the paddle displacement and in a frequency domain for adaptive controlling of the waves. Both of these areas are coupled by backward and forward Fast Fourier Transform – respectively IFFT and FFT blocks.

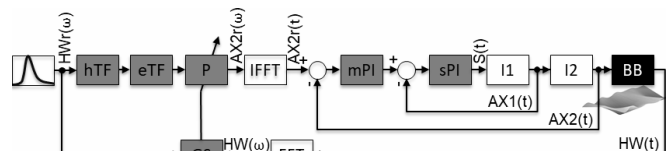

Fig. 3. Structural diagram of the adaptive control system with gain scheduling and Black-Box model.

Required spectrum of the wave $HW_r(\omega)$ is applied as the system input. Using hTF (Fig. 4) it is converted to required spectrum of the paddle displacement. Then, using eTF (Fig. 9) it is converted to required spectrum of the

voltage given to the electrohydraulic servo valve. Afterwards, using P' (Fig. 5) it is initially amplified according to (1) or (2), based on significant waveheight H_s for Pierson-Moskowitz or JONSWAP spectrum. After preliminary generation, the correction function $C(\omega)$ is calculated for Black-Box model according to (3), based on $HW_r(\omega)$ and measured wave spectrum-feedback $HW(\omega)$. Subsequently, calculated signal $AX2r(t)$ is given to input of the linear PI controllers in a cascade structure with paddle velocity control in the inner loop and paddle position control in the outer loop, so that paddle displacements generate the required spectrum of the wave.

$$P'_{P-M} = 0.65 \cdot \ln(H_s[cm]) - 0.15 \quad (1)$$

$$P'_{JWP} = 0.8 \cdot \ln(H_s[cm]) - 0.33 \quad (2)$$

$$C(\omega) = \frac{HW_r(\omega)}{HW(\omega)} \quad (3)$$

Moreover, the linear control of the paddle position, required a tuning of the linear PI controllers in a cascade structure. Therefore, the wavemaker actuators were experimentally identified and modelled. The electrohydraulic servo valve was identified and modelled as an integrator shown in Fig. 6. The hydraulic cylinder was identified and modelled as an integrator shown in Fig. 7. The ultimate gains and periods were determined using Aström-Hägglund tuning method for system with developed models [7]. Afterwards, the optimal parameters of the PI controllers were calculated using Ziegler-Nichols parameters and shown in Tab. 2. The stability and quality of regulation for system with optimized cascading PI controllers were checked under the Nyquist criterion and under the margin of stability criterion, as shown in Fig. 8 and Fig. 9. According to them, the system with optimized cascading PI controllers is stable due to the course of characteristic in reference to the critical point P_c (Fig. 8) and provides high quality of regulation due to 18 dB gain margin and 120° phase margin (Fig. 9).

Table 2. Optimal parameters of the cascading PI controllers

Parameter	sPI	mPI
K_p	0.575	0.546
T_i	0.328 s	1.298 s

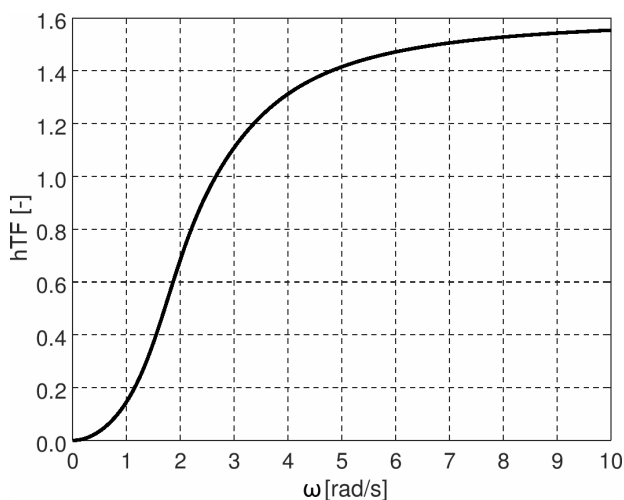

Fig. 4. The transfer function according to 1st order wavemaker theory for 5.69 m water depth

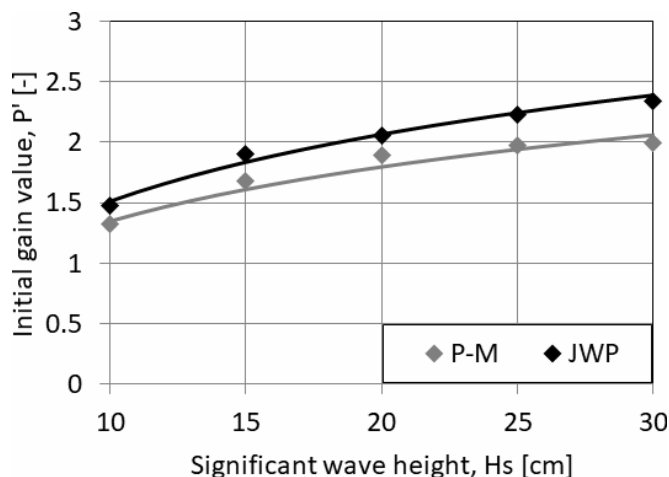

Fig. 5. Characteristics of initial gain scheduling – gain values calculated for measured discrete points (diamonds) and scheduling functions for significant wave height as a scheduling variable (lines)

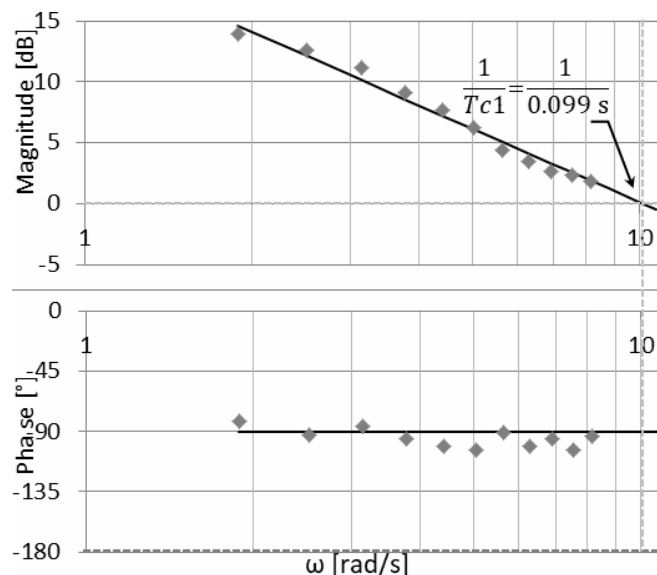

Fig. 6. Bode plot of the electrohydraulic servo valve – measurement (grey diamonds) and model for simulation (black lines)

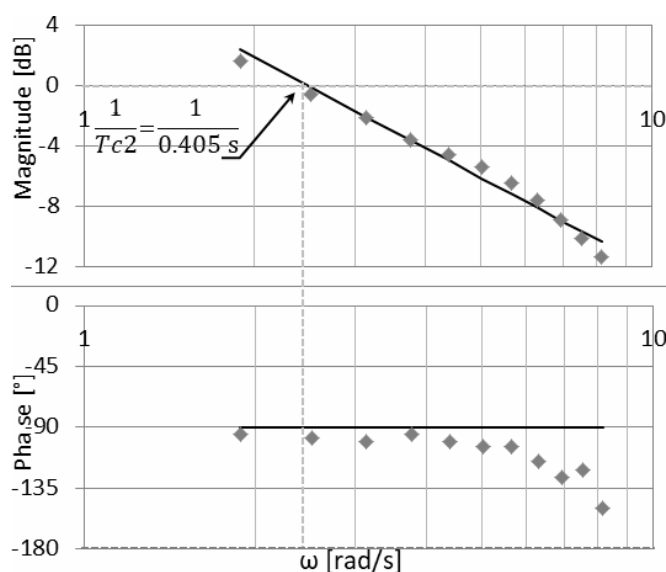

Fig. 7. Bode plot of the hydraulic cylinder – measurement (grey diamonds) and model for simulation (black lines)

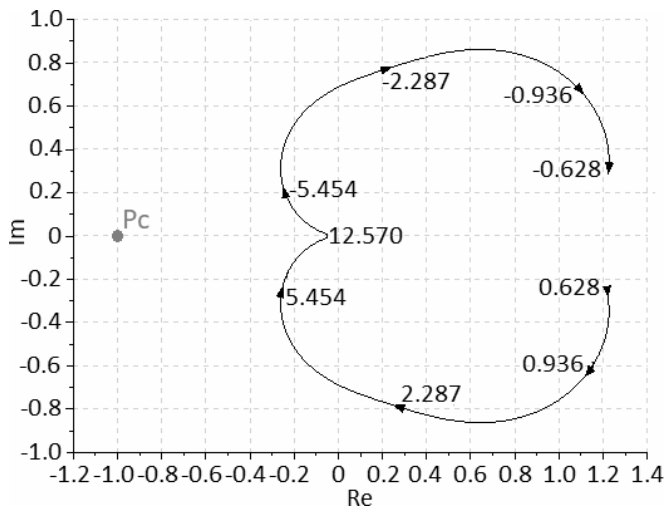

Fig. 8. Nyquist plot of the closed-loop system with optimized cascading PI controllers – simulation

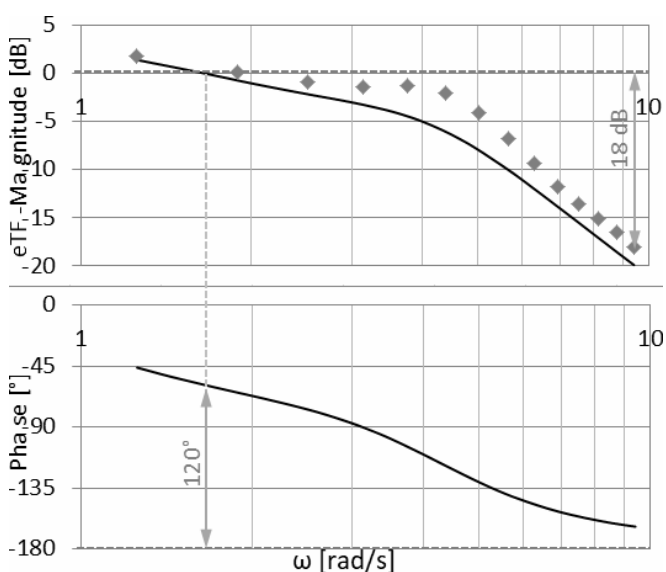

Fig. 9. Bode plot of the closed-loop system with optimized cascading PI controllers – measurement (grey diamonds) and simulation (black lines)

4.2. Implementation

The linear PI controllers in a cascade structure (Fig. 3) have been implemented into embedded system based on 32-bit processor (Fig. 10). Implementation of the recursive PI algorithm with rectangular approximation was done using .NET micro framework environment and C# language.

The hTF, eTF, P and GS modules (Fig. 3) has been implemented into Windows Form Application (Fig. 11) in .NET environment in C# language.

The positions of the servo valve and paddle are measured using linear displacement transducers. The $AX1(t)$ and $AX2(t)$ voltage signals are acquired by embedded system using wired connection.

The profile of the wave is measured using wave gauge placed in the halfway length of the deepwater towing tank axis. The $HW(t)$ voltage signal is acquired from wave gauge by embedded system using Wi-Fi connection.

The embedded system communicates with the Windows Form Application in RS-232 standard, using USB connection and virtual COM port.

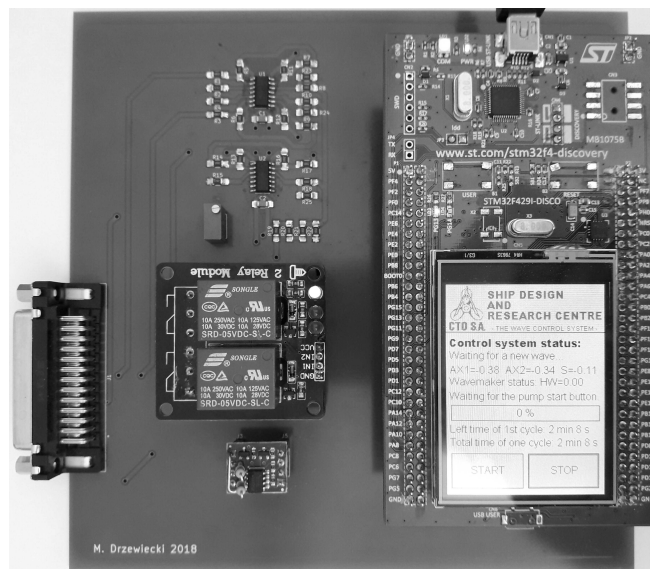

Fig. 10. Embedded system with 32-bit processor and graphical user interface

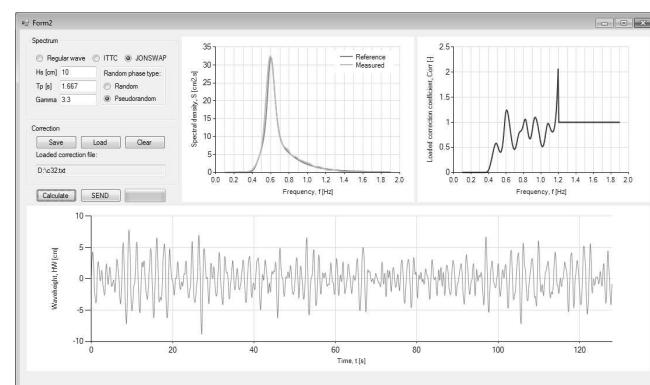

Fig. 11. Windows Form Application for modelling and analysis of the waves in the deepwater towing tank

4.3. Validation

Required accuracy of the waves modeling specified in terms of significant wave height and is equal to $\frac{1}{4}$ of the number defining the sea state according to [1]. This means that e.g. for sea state 6 (mean $H_s=5m$), taking into account the significant wave heights for sea state 5 (mean $H_s=3.25m$) and sea state 7 (mean $H_s=7.5m$), the significant wave height should not be higher than 5.53 m and lower than 4.47 m. Such accuracy allows to unequivocally model the required sea state. The scale factor of 30 has been adopted. Such value includes the actual scale factors used in model tests in waves.

The validation consisted in modelling selected sea states in reduced scale using developed system. The sea states SS have been selected in agreement with common requirements for model tests in waves. Achieved accuracy δH_s^M has been compared with required accuracy of $\frac{1}{4}$ of the sea state number δH_s^R . The results are shown in Tab. 3. The wave spectra – measured and required for specified sea state – are shown in Fig. 12..17.

As it proven, accuracy meets the requirement of $\frac{1}{4}$ of sea state number adopted for this investigation.

Table 3. Expectations and results of the validation

SS	Hs	Tp	δH_s^R	δH_s^M	
				Pierson-Moskowitz	JONSWAP
-	cm	s	%	%	%
5	10.0	1.667	11.9	1.7	2.6
6	15.0	2.500	11.1	4.6	3.1
7	25.0	2.500	10.0	0.2	3.6

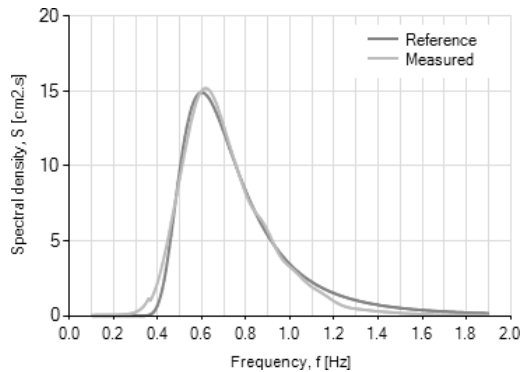

Fig. 12. The Pierson-Moskowitz wave energy spectra for 5 state of sea – desired (dark grey) and measured (light grey)

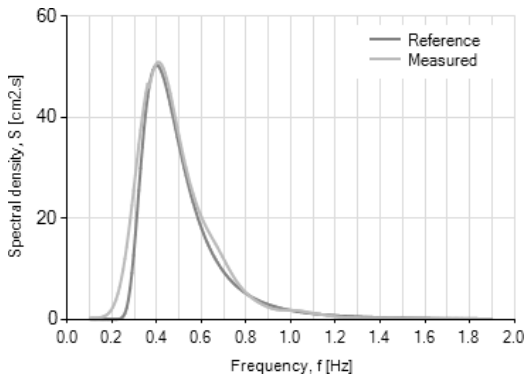

Fig. 13. The Pierson-Moskowitz wave energy spectra for 6 state of sea – desired (dark grey) and measured (light grey)

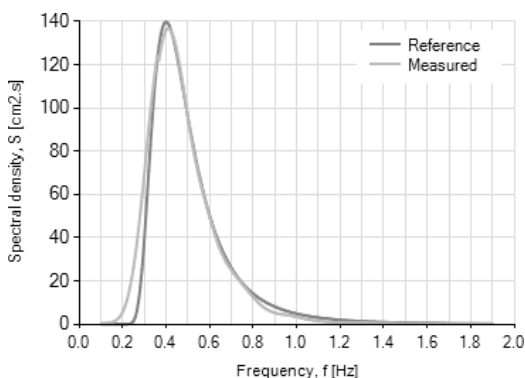

Fig. 14. The Pierson-Moskowitz wave energy spectra for 7 state of sea – desired (dark grey) and measured (light grey)

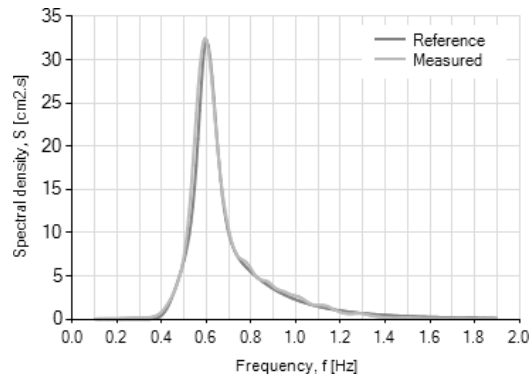

Fig. 15. The JONSWAP($\gamma=3.3$) wave energy spectra for 5 state of sea – desired (dark grey) and measured (light grey)

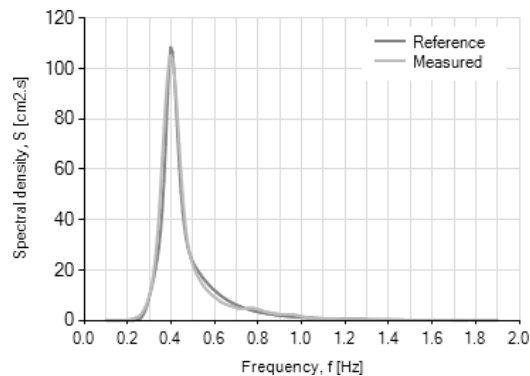

Fig. 16. The JONSWAP($\gamma=3.3$) wave energy spectra for 6 state of sea – desired (dark grey) and measured (light grey)

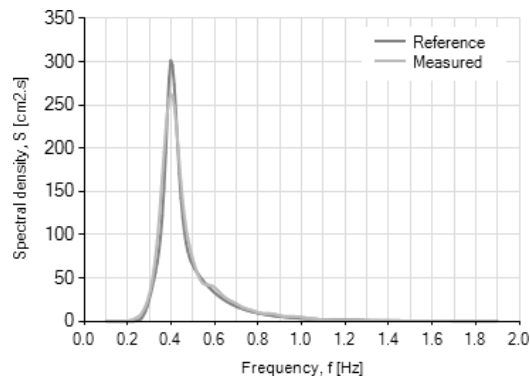

Fig. 17. The JONSWAP($\gamma=3.3$) wave energy spectra for 7 state of sea – desired (dark grey) and measured (light grey)

5. CONCLUSION

The implemented adaptive control system with gain scheduling and Black-Box model allows modelling required Pierson-Moskowitz and JONSWAP spectra in expected scope and with required accuracy, omitting complicated hydromechanical models.

The presented solution is low-cost and simple to implement. Moreover, it is ready-made solution which can be implemented for wavemakers with single unit paddle and hydraulic drive. It is particularly important due to the fact that 61.1 % of the wavemakers in towing tanks worldwide are single unit and 43.2% are equipped with hydraulic driving mechanism [2].

6. ACKNOWLEDGEMENT

The research was financed by Ministry of Science and Higher Education of the Republic of Poland and by CTO S.A. Ship Design and Research Centre.

7. REFERENCES

1. Cox G. G. et al., Report of the Seakeeping Committee, Proceedings of 17th ITTC, 1984, Volume I, p. 482.
2. Iafrati A. et al., Report of the Specialist Committee on Modelling of Environmental Conditions, Proceedings of 28th ITTC, September 2017, Volume II, Appendix A.
3. Stansberg C. T. et al., The Specialist Committee on Waves. Final Report and Recommendations to the 23rd ITTC, Proceedings of 23th ITTC, 2002, Volume II, Appendix A, pp. 545-547.
4. Biésel F., Suquet F.: Les appareils générateurs de houle en laboratoire, La Houille Blanche, no. 2, 1951, pp. 161-163.
5. Sulisz W., Hudspeth R. T.: Complete Second-Order Solution for Water Waves Generated in Wave Flumes, Journal of Fluids and Structures, Volume 7, Issue 3, April 1993, pp. 253-268.
6. Drzewiecki M.: The propagation of waves in the CTO S.A. towing tank, Twenty First International Conference on Hydrodynamics in Ship Design and Operation, HYDRONAV 2017, 28-29 June 2017.
7. Drzewiecki M.: Modelling, Simulation and Optimization of the Wavemaker in a Towing Tank, Trends in Advanced Intelligent Control, Optimization and Automation, Springer International Publishing AG, June 2017, pp. 570-579.

STEROWANIE FAŁAMI BASENOWYMI Z UŻYCIEM MODELU TYPU BLACK-BOX

Artykuł opisuje adaptacyjny system sterowania falami basenowymi, który został wdrożony w Centrum Techniki Okrętowej (CTO) S.A. Fale są generowane w głębokowodnym basenie holowniczym podczas testów modelowych w celu odwzorowania warunków oddziaływania środowiska morskiego. Testy są przeprowadzane na modelach holowanych lub pływających swobodnie (statki), zakotwiczonych (platformy) lub przymocowanych trwale do dna (turbiny wiatrowe). W głębokowodnym basenie holowniczym CTO S.A., fale generowane są przez płytkowy wywoływalcz fal z płytą mocowaną powyżej dna basenu i z napędem hydraulicznym. Adaptacyjne sterowanie falą basenową obejmuje harmonogramowanie wzmocnienia i model typu Black-Box. Opracowany system sterowania został implementowany w 32-bitowym systemie wbudowanym i aplikacji komputerowej w języku C# w środowisku .NET. Wprowadzony model typu Black-Box uwzględnia efekty hydromechanicznych procesów i zjawisk – m. in. rozpadu, odbicia, tłumienia i nieliniowego transferu energii – które mają wpływ na generowane fale. Przedstawione rozwiązanie pozwala w prosty sposób i z oczekiwaną dokładnością modelować zadane widma fal basenowych.

Słowa kluczowe: sterowanie adaptacyjne; model typu Black-Box; wywoływalcz fal.