

Ampacity of power cables exposed to solar radiation – recommendations of standards vs. CFD simulations

Stanislaw Czapp^{1,*}, Marian Czapp², Seweryn Szultka¹, and Adam Tomaszewski³

¹Gdansk University of Technology, Faculty of Electrical and Control Engineering, ul. Narutowicza 11/12, PL-80-233 Gdansk, Poland

²Koszalin University of Technology, Faculty of Mechanical Engineering, ul. Raclawicka 15-17, PL-77-620 Koszalin, Poland

³Polish Academy of Sciences, Institute of Fluid-Flow Machinery, ul. Fiszerza 14, PL-80-231 Gdansk, Poland

Abstract. Ampacity of power cables strictly depends on the ambient conditions. It is very important whether a cable is buried in soil, installed in the air or placed in ducts. When a cable is installed in free air, potential solar radiation has the dominant impact on the prospective ampacity. International standards indicate how to calculate ampacity of power cables exposed to solar radiation, however the standards' recommendations are characterised by some simplifications. In order to consider many complex factors influencing ampacity of power cables, and modelling advanced heat transfer phenomena, a Computational Fluid Dynamics (CFD) can be used. This paper presents a comparison of ampacity calculation of an example power cable for two approaches – first: according to international standards; second: with a CFD employed. Differences in results obtained for these two approaches are commented.

1 Introduction

One of the most important issues which influence ampacity^a of power cables is solar radiation [1-7]. Methods of calculation of ampacity of power cables are conducted in the standard IEC 60287 [8, 9]. According to this standard, ampacity of power cables exposed to solar radiation can be calculated as follows:

$$I_{amp} = \sqrt{\frac{\Delta\theta - W_d \cdot [0.5 \cdot T_1 + n_c \cdot (T_2 + T_3 + T_4^*)] - \sigma \cdot D_e \cdot H \cdot T_4^*}{R \cdot T_1 + n_c \cdot R \cdot (1 + \lambda_1) \cdot T_2 + n_c \cdot R \cdot (1 + \lambda_1 + \lambda_2) \cdot (T_3 + T_4^*)}} \quad (1)$$

where:

I_{amp} – ampacity of power cables, A,

$\Delta\theta$ – permissible temperature rise of the conductor above ambient temperature, K,

W_d – dielectric losses per unit length per phase, W/m,

T_1 – thermal resistance per core between the conductor and sheath, (K·m)/W,

T_2 – thermal resistance between the sheath and armour, (K·m)/W,

T_3 – thermal resistance of external serving of the cable, (K·m)/W,

T_4^* – external thermal resistance in free air, adjusted for solar radiation, (K·m)/W,

n_c – number of conductors in a cable, -,

^a ampacity – (International Electrotechnical Vocabulary) maximum value of electric current which can be carried continuously by a conductor, a device or an apparatus, under specified conditions without its steady-state temperature exceeding a specified value.

σ – absorption coefficient of solar radiation for the cable surface, -,

D_e – external diameter of cable (with insulation), mm,

H – intensity of solar radiation (for most latitudes can be assumed as 10^3 W/m²); it is recommended to assume a local value, W/m²,

R – AC current resistance of a conductor at its maximum operating temperature, Ω /m,

λ_1 – ratio of the total losses in metallic sheaths to the total conductor losses, -,

λ_2 – ratio of the total losses in metallic armour to the total conductor losses, -.

In general, calculation of the ampacity according to the recommendations of the standard IEC 60287 [8, 9] requires assumption of values of many coefficients, as well as the use of iterative or graphical methods of their calculation. Moreover, recommendations of the standard do not cover all types of cables installation and possible influences of external factors.

Ampacity of power cables can also be calculated with the use of a Computational Fluid Dynamics (CFD) method. It is possible to simulate various complex ambient conditions, mainly: intensity and direction of solar radiation, wind speed, consequences of vertical installation vs. horizontal installation of the cables. This method of calculation, although time-consuming, allows for relatively accurate evaluation of the ampacity in complex cable laying conditions. The aim of this paper is to evaluate the ampacity of a low-voltage single power cable, according to:

- recommendations of the standard IEC 60287 [8-10],

* Corresponding author: stanislaw.czapp@pg.edu.pl

- a Computational Fluid Dynamics method, implemented in Ansys software, and comparison of the results obtained for these two cases. Moreover, limitations of recommendations of the above mentioned standard are indicated.

2 Results of calculations according to the standard IEC 60287

Low-voltage power cables construction is relatively simple – they are usually composed of a copper or aluminium conductor and insulation. In this paper a power cable with copper conductor and PVC insulation is considered (Fig. 1). The simplicity of the construction of such cables makes the values of many quantities and coefficients in (1) equal to 0. The zero value can be assigned to: $W_d, T_2, T_3, \lambda_1, \lambda_2$.

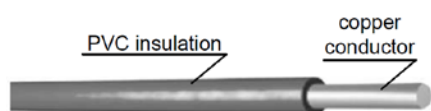

Fig. 1. Construction of the analyzed low-voltage power cable.

Taking into account the above simplification, ampacity of the considered single power cable ($n_c = 1$) can be calculated according to the following expression:

$$I_{amp} = \sqrt{\frac{\Delta\theta - \sigma \cdot D_e \cdot H \cdot T_4^*}{R \cdot (T_1 + T_4^*)}} = \sqrt{\frac{\Delta\theta - \Delta\theta_{red}}{R \cdot (T_1 + T_4^*)}} \quad (2)$$

where:

$\Delta\theta_{red}$ – reduction of the permissible temperature rise of the conductor, due to solar radiation, K.

Thermal resistance T_1 , between the conductor and sheath of the cable, is described by the dependence:

$$T_1 = \frac{\rho_T}{2\pi} \ln\left(1 + \frac{2 \cdot \delta}{D_w}\right) \quad (3)$$

where:

ρ_T – thermal resistivity of insulation, (K m)/W,

δ – thickness of the cable insulation, mm,

D_w – external diameter of conductor, mm,

whereas external thermal resistance T_4^* in free air, adjusted for solar radiation, is calculated as follows:

$$T_4^* = \frac{1}{\pi \cdot D_e \cdot h \cdot (\Delta\theta_s)^{0.25}} \quad (4)$$

where:

h – heat dissipation coefficient, -,

$\Delta\theta_s$ – temperature difference between the surface of a cable in the air and ambient temperature, K.

The heat dissipation coefficient h and the temperature difference $\Delta\theta_s$ between the cable surface in the air and ambient air are defined as follows:

$$h = \frac{Z}{D_e^d} + E \quad (5)$$

$$\Delta\theta_{s_{n+1}} = \frac{\Delta\theta + \Delta\theta_d + \Delta\theta_{ds}}{1 + K_A \cdot (\Delta\theta_{s_n})^{0.25}} \quad (6)$$

where:

d, E, Z – constants for black surfaces of cables in free air (values included in table 2 in IEC 60287-2-1 [9]), -,

$\Delta\theta_d$ – factor for calculation T_4^* for cables in free air, including dielectric loss, K,

$\Delta\theta_{ds}$ – factor indicating temperature difference of cable insulation due to direct solar radiation, K,

K_A – factor for calculation of external thermal resistance of cables in air, -.

The temperature difference $\Delta\theta_s$ is calculated in an iterative way – value of a step of calculation $n+1$ in relation to a previous step (n) should fulfill the following requirement:

$$(\Delta\theta_{s_{n+1}})^{0.25} - (\Delta\theta_{s_n})^{0.25} \leq 0.001 \quad (7)$$

Factor K_A , for calculation of external thermal resistance of the cable in the air, is defined by the following dependence:

$$K_A = \pi \cdot D_e \cdot h \cdot T_1 \quad (8)$$

whereas factor $\Delta\theta_{ds}$ indicating the temperature difference of the cable insulation, due to direct solar radiation, is calculated according to the expression:

$$\Delta\theta_{ds} = \sigma \cdot D_e \cdot H \cdot T_1 \quad (9)$$

The arrangement of the analyzed power cable is presented in Fig. 2. The external diameter of the conductor is $D_w = 7.2$ mm (nominal catalogue value of cross-sectional area equals 35 mm^2), and the external diameter of the PVC insulation is $D_e = 12.4$ mm. The temperature of the ambient air is equal to $25 \text{ }^\circ\text{C}$ (typical value for Poland – according to the standard [10]). The solar radiation is assumed to be at an angle of 45° .

Calculation of ampacity of the power cable has been conducted for various values of absorption coefficient of solar radiation σ (Fig. 3a) and intensity of solar radiation H (Fig. 3b).

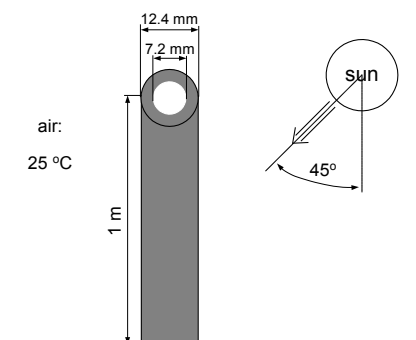

Fig. 2. An arrangement of the analyzed power cable.

Values of coefficients and constants used in calculations are included in Tab. 1. When intensity of solar radiation is assumed to be $H = 1000 \text{ W/m}^2$, and σ varies from 0 to 1, ampacity I_{amp} is within the range 191–148 A, respectively. Similar results have been obtained for variations of solar radiation intensity H from 0 to 1300 W/m^2 (for $\sigma = 0.9$) – ampacity I_{amp} is within the range 191–139 A, respectively. It can be concluded that variation of the most important factors influencing cables ampacity changes (decreases) its value no more than 30% (when a reference value is a maximal ampacity 191 A).

Table 1. Values of coefficients assumed/calculated according to IEC 60287 [8, 9], and other constants.

Quantity	Unit	Value	Quantity	Unit	Value
d	-	0.60	δ	mm	2.6
h	-	6.865	D_e	m	0.0124
E	-	3.94	R	Ω/m	0.000624
Z	-	0.21	K_λ	-	0.116
n_c	-	1	$\Delta\theta$	K	45
ρ_l	$\frac{\text{Km}}{\text{W}}$	5	$W_1, T_2, T_3, \lambda_1, \lambda_2, \Delta\theta_{ai}$		0

Decreasing of ampacity of power cables is a consequence of reduction of the permissible temperature rise of the conductor above ambient temperature (due to solar radiation). This reduction $\Delta\theta_{red}$ is expressed by the following formula:

$$\Delta\theta_{red} = \sigma \cdot D_e \cdot H \cdot T_4^* \quad (10)$$

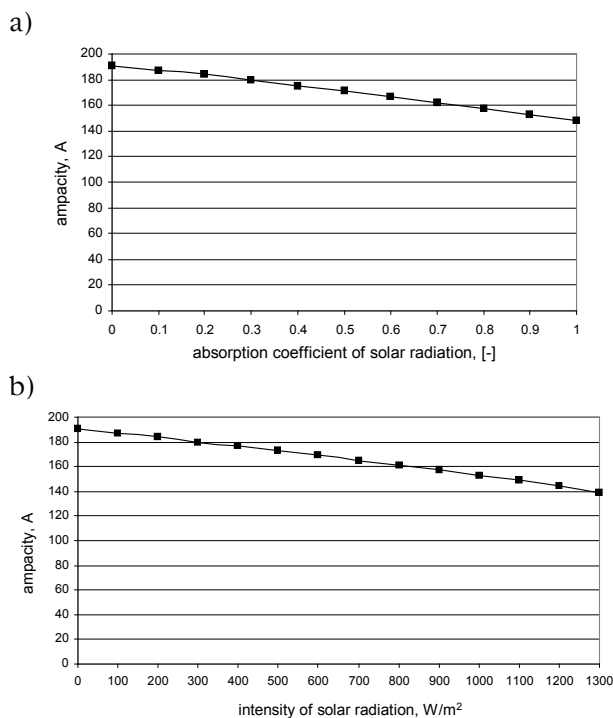

Fig. 3. Ampacity I_{amp} of the analyzed power cable as a function of: a) absorption coefficient σ of solar radiation ($H = \text{const} = 1000 \text{ W/m}^2$), b) intensity of solar radiation H ($\sigma = \text{const} = 0.9$).

The reduction depends on absorption coefficient of solar radiation for the cable surface σ , intensity of solar radiation H , external thermal resistance in free air T_4^* and external diameter of cable D_e . For the following values of the above mentioned coefficients: $\sigma = 0.9$, $H = 1120 \text{ W/m}^2$, reduction of the permissible temperature rise is equal to $\Delta\theta_{red} = 19 \text{ K}$ (ampacity equals $I_{amp} = 148 \text{ A}$). Such a reduction seems to be too little, especially if it is referred to data included in the paper [1]. It is concluded in this paper that temperature rise above outdoor temperature in full sunlight, inside metal conduits, may reach even 40 K, when cables are installed on the rooftop. Taking this conclusion into account, calculation of ampacity of the analyzed power cable (according to (2)), as a function of reduction of permissible temperature rise of the conductor above ambient temperature $\Delta\theta_{red}$, has been performed (Fig. 4).

The ampacity drastically decreases when $\Delta\theta_{red} > 35 \text{ K}$. For $\Delta\theta_{red} = 40 \text{ K}$ ampacity is equal only to $I_{amp} = 64 \text{ A}$, (instead of $I_{amp} = 191 \text{ A}$ for $\Delta\theta_{red} = 0 \text{ K}$), and for $\Delta\theta_{red} = 44 \text{ K}$ ampacity is equal to $I_{amp} = 29 \text{ A}$. The analyzed power cable cannot be loaded at all if reduction of the permissible temperature rise is $\Delta\theta_{red} \geq 45$. Such values ($\Delta\theta_{red} \geq 45$) can not be excluded in extremely unfortunate ambient conditions for cables exposed to direct solar radiation (e.g. on the rooftop, without thermal protection in place where air stagnation occurs). Heat transfer (heat dissipation) from the cable to the ambient air is deteriorated. Thus, advanced modelling of the cable's ampacity, with the use of a CFD method, has been performed.

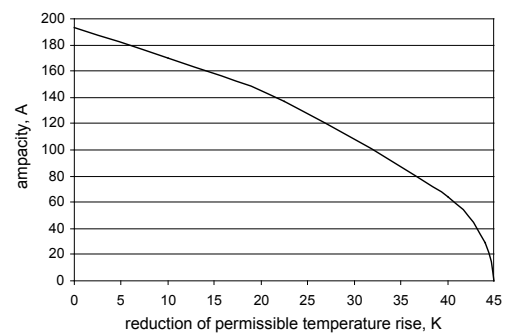

Fig. 4. Ampacity I_{amp} of the analyzed power cable as a function of reduction of permissible temperature rise $\Delta\theta_{red}$ of the conductor above ambient temperature.

3 Results of calculations with the use of CFD simulations

In CFD simulations heat flux density q_s (W/m^2) from solar radiation, delivered to the surface of cable insulation, is evaluated on the base of the Westman's equation [11]. This equation is modified and multiplied by the PVC absorption coefficient $\sigma = 0.9$ of PVC insulation and the cosine of incidence angle θ_{sun} ($^\circ$) of sunrays.

$$q_s(\theta_{sun}) = \sigma \cdot \cos \theta_{sun} \cdot H \cdot 10^{-0.05675m + 0.00038m^2} \quad (11)$$

where: $H = \text{const} = 1120 \text{ W/m}^2$; $m = 1/\sin A_L$; $A_L \approx 45^\circ$ – the sun’s altitude.

The expression (11) is converted to the relationship $q_s(x)$:

$$q_s(x) = \sigma \cdot \frac{\sqrt{r_e^2 - x^2}}{r_e} \cdot H \cdot 10^{-0.05675m + 0.00038m^2} \quad (12)$$

where:

x – coordinate, r_e – external radius of the insulation, mm.

Results of simulations are presented in Fig. 5. When the cable is not exposed to solar radiation, its ampacity is equal to $I_{\text{amp}} = 190 \text{ A}$. This value is in good convergence with the result ($I_{\text{amp}} = 191 \text{ A}$) obtained by calculations according to the standard [8, 9]. When solar radiation is taken into account, the ampacity $I_{\text{amp}} = 142 \text{ A}$ – this value is also consistent with the standard ($I_{\text{amp}} = 148 \text{ A}$).

In contrast to the rules of cables ampacity calculation presented in the standard IEC 60287 [8, 9], CFD simulations enable modelling of extremely unfavorable ambient condition, which results in deteriorated heat transfer from cables to ambient air. It may occur on a rooftop in a place which is shielded from wind (air is almost in full stagnation), especially when power cables are exposed to solar radiation, or they are in closed conduits surrounded by hot air. In such cases, the radiation heat emitted from the cable to the environment is comparable to the heat supplied by radiation to the surface of the cable from surrounding structures (e.g. rooftop, shield). Thus, in further considerations it has been assumed that heat transfer by radiation, from the cable to the environment, does not occur.

Such an assumption makes that ampacity of the analyzed power cable drastically decreases. When the cable is not exposed to solar radiation, and almost full air stagnation occurs, its ampacity is equal to $I_{\text{amp}} = 137 \text{ A}$. It is a significantly lower value than for calculation performed according to the standard [8-10] – (191 A), as well as value obtained in the previous simulation (190 A). Moreover, when solar radiation with the assumed parameters is taken into account, the cable cannot be loaded at all. The highest permissible temperature of the PVC insulation (70 °C) is achieved only by insulation, without any current in the cable conductor. Comparison of calculation results is presented in Tab. 2.

Due to solar radiation and air stagnation, temperature of the air surrounding a cable may significantly rise. The heat radiated from the surrounding elements contributes significantly to the heat balance of the power cable. Additionally, part of the radiation reflected from the surrounding surfaces (e.g. rooftop) may return to the surface of a cable. Result of the CFD simulations confirm observations commented in [1]. Solar radiation may force a reduction of the permissible temperature rise of the conductor above ambient temperature significantly, more than recommended by the standard. This conclusion may also be an explanation of power cables damages, which are described in [12]. The power cables were put into operation during autumn, and operated properly till the nearest summer. During the

summer, damages of power cables occurred, even though they were loaded only a little. Temperature of the PVC insulation might significantly exceed 70 °C even for a slight current load.

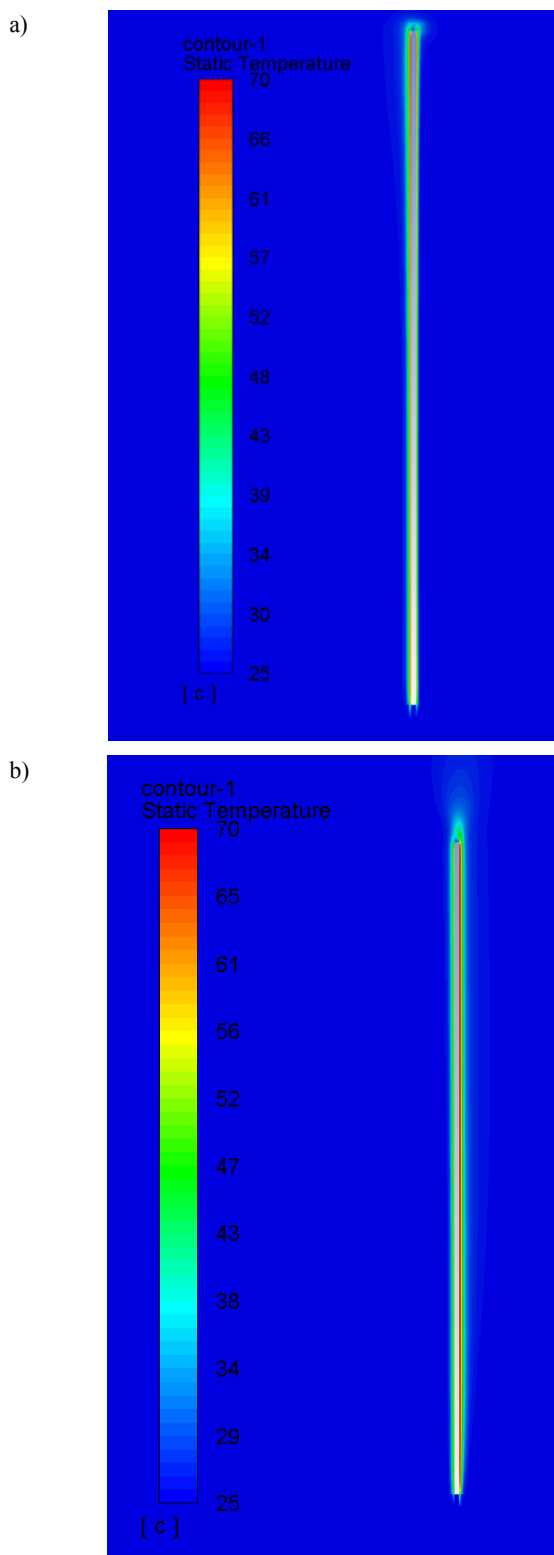

Fig. 5. Temperature distribution around a single power cable (PVC insulation max permissible temperature: 70 °C): a) without solar radiation, wind from bottom to top $v_w = 0.01 \text{ m/s}$, value of current $I_{\text{amp}} = 190 \text{ A}$, b) with solar radiation, wind from bottom to top $v_w = 0.01 \text{ m/s}$, value of current $I_{\text{amp}} = 142 \text{ A}$.

Table 2. Comparison of calculation results.

Calculation according to	Ampacity, A	
	no solar radiation	solar radiation $H = 1120 \text{ W/m}^2$
IEC 60287	191	148
CFD simulations	190	142
CFD simulations, air stagnation, heat radiation from the cable excluded	137	0

4 Conclusions

Solar radiation is a major factor influencing ampacity of power cables installed in free air. As it has been conducted in the CFD simulations, solar radiation may drastically reduce ampacity of power cables – for PVC-insulated power cables this ampacity may be close to 0. For power cables installed in free air, the heat dissipated by radiation needs to be taken into account, whereas for power cables surrounded by certain structures, radiated heat may be reduced depending on the case. It seems that calculation of ampacity of power cables according to recommendations of the international standards gives too optimistic results, for an adverse, strong solar radiation and air stagnation. It may lead to damage of cables.

References

1. D. Brender, T. L. Lindsey, IEEE T. on Ind. Appl., **44**, pp. 1872-1878 (2008)
2. S. Czapp, S. Szultka, A. Tomaszewski, *CFD-based evaluation of current-carrying capacity of power*

cables installed in free air, 18th Int. Conf. on El. Power Eng. (EPE), Kouty nad Desnou, pp. 692-697 (2017)

3. C. Holyk, G. J. Anders, IEEE Ind. App. Mag., **21**, pp. 6-64 (2015)
4. F. de Leon, *Major factors affecting cable ampacity*, IEEE Power Eng. Soc. Gen. Meeting (PES), (2006)
5. Y. Liang, J. Zhao, Y. Du, J. Zhang, Przegł. Elektrot., **3b**, pp. 156-160 (2012)
6. A. Sedaghat, F. de Leon, IEEE T. on Pow. Del. **29**, pp. 2306-2314 (2014)
7. W. Zhang, H.-J. Li, Ch. Liu, K. Ch. Tan., *A technique for assessment of thermal condition and current rating of underground power cables installed in duct banks*, Asia-Pac. Pow. and En. Eng. Conf., Shanghai, (2012)
8. IEC 60287-1-1: *Electric cables – Calculation of the current rating – Part 1-1: Current rating equations (100% load factor) and calculation of losses – General* (2006)
9. IEC 60287-2-1: *Electric cables – Calculation of the current rating – Part 2-1: Thermal resistance – Calculation of the thermal resistance* (2015)
10. IEC 60287-3-1: *Electric cables – Calculation of the current rating – Part 3-1: Operating conditions – Site reference conditions* (2017)
11. S.A. Andersen, *Automatic refrigeration* (Published by MacLaren for Danfoss, Denmark, 1959)
12. F. Spyra, Energetyka, **6-7**, pp. 451-454 (2007)