

Finite element simulation of cross shaped window panel supports

A. Ambroziak

Gdansk University of Technology, Faculty of Civil and Environmental Engineering, Poland

This is an Accepted Manuscript of a book chapter published by CRC Press in Shell Structures: Theory and Applications Volume 4 : Proceedings of the 11th International Conference "Shell Structures: Theory and Applications, (SSTA 2017), October 11-13, 2017, Gdansk, Poland on 2017, available online: <https://doi.org/10.1201/9781315166605>

ABSTRACT: The aim of the work is to verify suitability of cross-shaped window panel supports for mullion-transom wall systems. The Finite Element Method (FEM) is chosen to determine the behaviour of stainless steel elements under loading. The advanced non-linear numerical simulations are carried out using an implicit FEM software package MSC.Marc. This study is proposed to initiate the comprehensive investigation of mechanical properties of cross-shaped window panel supports.

1 INTRODUCTION

Engineering practice of design and construction provides many interesting experiences. Additionally, the building site supervision makes it possible to recognize new technologies and applications of new materials. The author performs construction site supervision on the Alchemia building site in Gdańsk where the mullion-transom wall system is applied for the facade. The Alchemia (see Figure 1) is a modern multi-purpose complex in Gdańsk, Poland. It covers office spaces and supplies a sports and recreation facility offering a swimming pool, a sports hall, fun climbing zone and a gym.

The mullion-transom wall systems are designed for the construction and execution of flat, light-weight curtain walls of the suspension or filling types, roofs, skylights and other structures. Transom curtain walls are installed on the site after preparing all constituent elements in the factory. The vertical elements (mullions) are usually fixed to the load-bearing structure first. After fixing the mullions, the horizontal elements (transoms) are added, then finally glazed. The horizontal and vertical elements of the frame are made from extruded aluminium profiles (EN AW-6060 T66 aluminium alloy).

While the dimensions of the window panels transgress the curtain wall systems limits it is necessary to perform additional design solutions. Stainless steel cross-shaped window panel supports (see Figure. 2) are designed to assure safety while carrying operational and climatic loads. Numerical investigations are performed to confirm that the additional stainless steel supports function well and conform to the quality standards properly.



Figure 1. Mullion-transom wall system in office tall buildings.

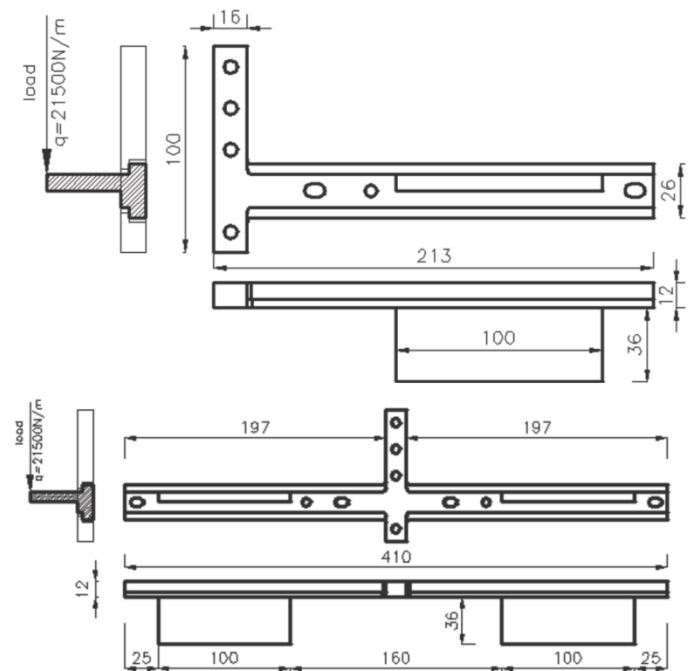

Figure 2. Stainless steel cross-shaped windows panel supports

2 NUMERICAL INVESTIGATIONS

In order to determine the behaviour of stainless steel cross-shaped window panel supports (see Figure 2, Figure 3) under operational loads numerical simulations were performed. Two three-dimensional (3-D) models shown in Figure 4 are taken into account in the finite element analysis. The models apply four-node, isoparametric three-dimensional tetrahedron elements (Element 134, see User Documentation Marc, 2016).

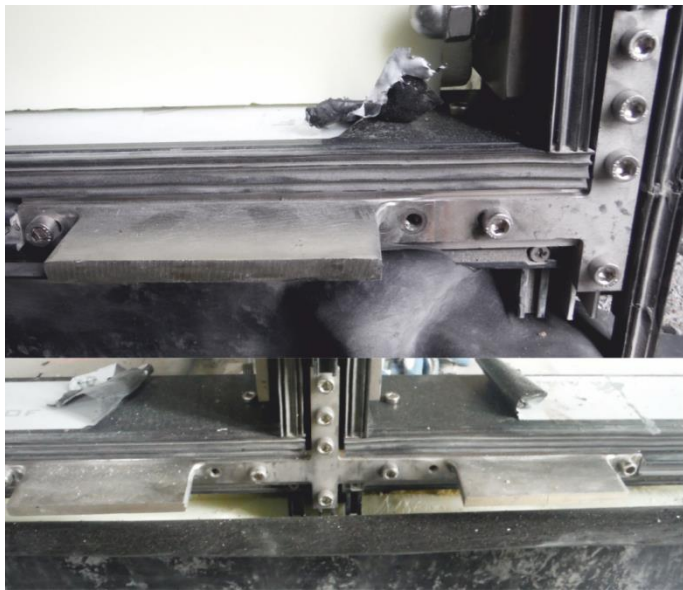

Figure 3. Application of the stainless steel cross shaped windows panel supports in mullion-transom wall system

The cross-shaped window panel supports are made of stainless steel brand 1.4301 and 1.4362. Austenitic stainless steel bolts of grade A2 property class 70 are applied to fastened elements to mullions and transoms (see Figure 3). The input mechanical properties of the material used in the finite element analysis are given in Table 1. General mechanical properties are specified in the standard EN 1993-1-4 (2006) for the design of stainless steel structures.

Numerical simulations are carried out using an implicit FEM software package MSC.Marc. Two body contacts models are specified (see Figure 4): a plate with bolts and a cross-shaped window support with console. The bottom face of a steel plate is supported (the translations U_x , U_y and U_z are fixed). The material of the plate, bolts and the cross-shaped window support is assumed plastic during analysis.

Table 1. Material properties, EN 1993-1-4 (2006)

	1.4362	A2-70	1.4301
Tensile modulus [GPa]	200	200	200
Poisson's ratio [-]	0.3	0.3	0.3
Yield strength [MPa]	400	450	210

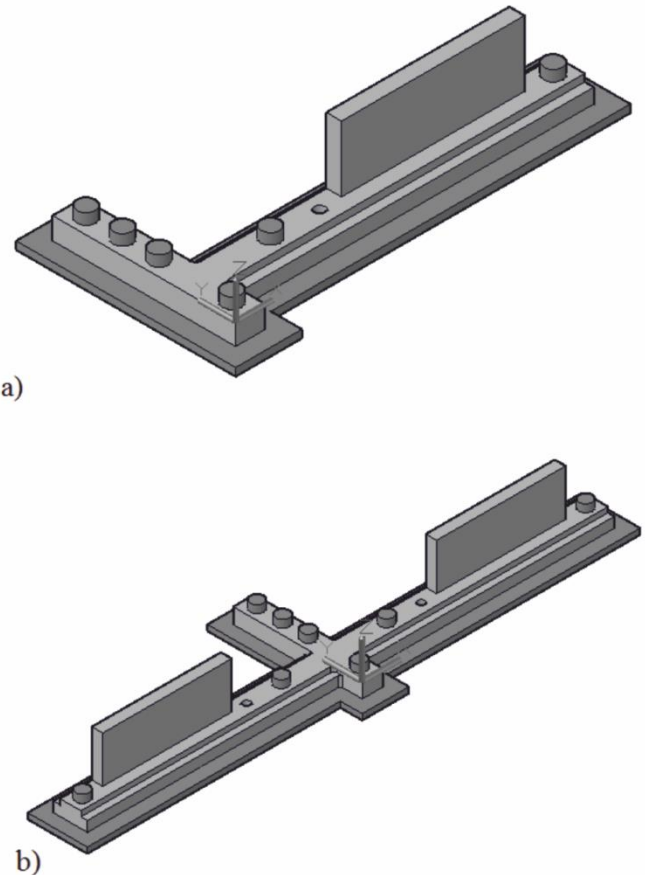

Figure 4. 3D models of the stainless steel cross shaped windows panel support: a) model_1, b) model_2

The load applied on the edge of the steel console is assumed uniformly distributed, equal 21500 N/m and applied on the 0.1 m distance (see Figure 2). The load resultant equals 2.15 kN. This load is classified as a permanent action, connected to the self-weight of the window panel. The computations employ the action combinations for the ULS (ultimate limit states) and SLS (serviceability limit states).

Total displacement (the vector sum of U_x , U_y and U_z displacements) maps are presented in Figure 5. The model_1 with a single window panel support detects the maximum total displacement approximately equal to 0.306 mm. On the other hand, the model_2 with double window panel supports the maximum total displacement is about 0.296 mm. The difference in the total displacements is 3% only. The stainless steel cross-shaped window panel supports exhibit small deformations, thus meeting the SLS requirements. It should be noted that the deformations should be kept within limits to make the window panels stiff enough.

The contact status for the model_1 and model_2 are presented in Figure 6. The shaded areas on the contact status maps indicate the zones without contact with base plate. In the support zones the upper area of the cross-shaped elements shows no contact. It confirms the behaviour of elements under load applied on edge of the steel console.

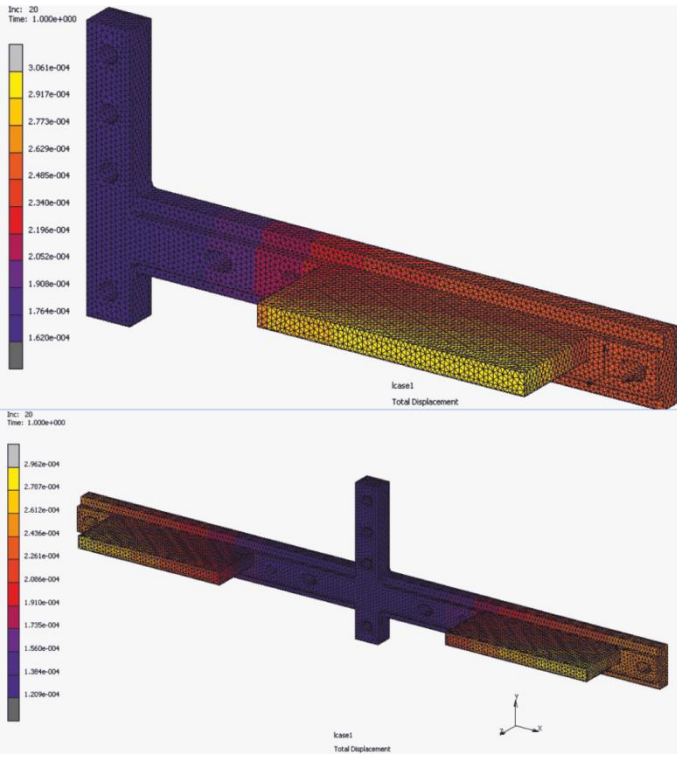

Figure 5. Numerical results – total displacement

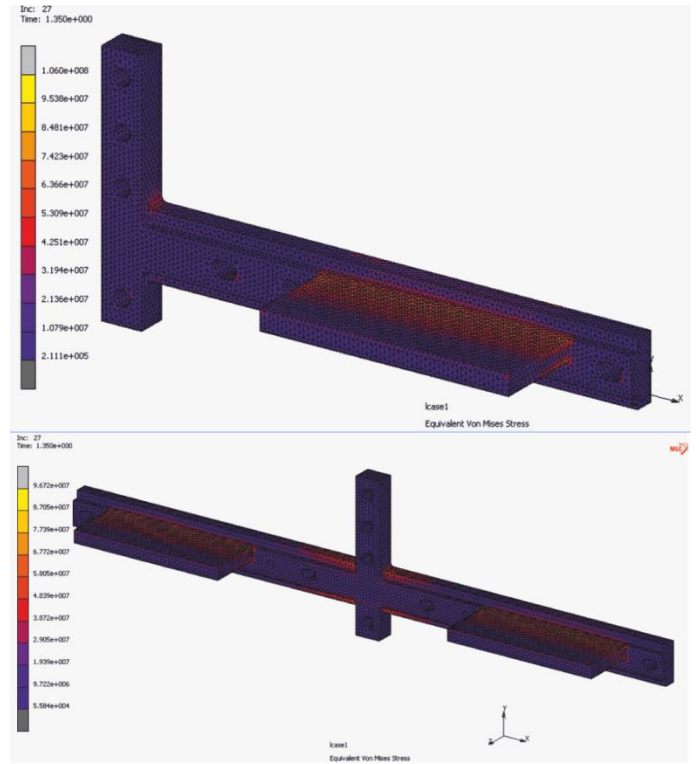

Figure 7. Numerical results – HMH stresses for main elements

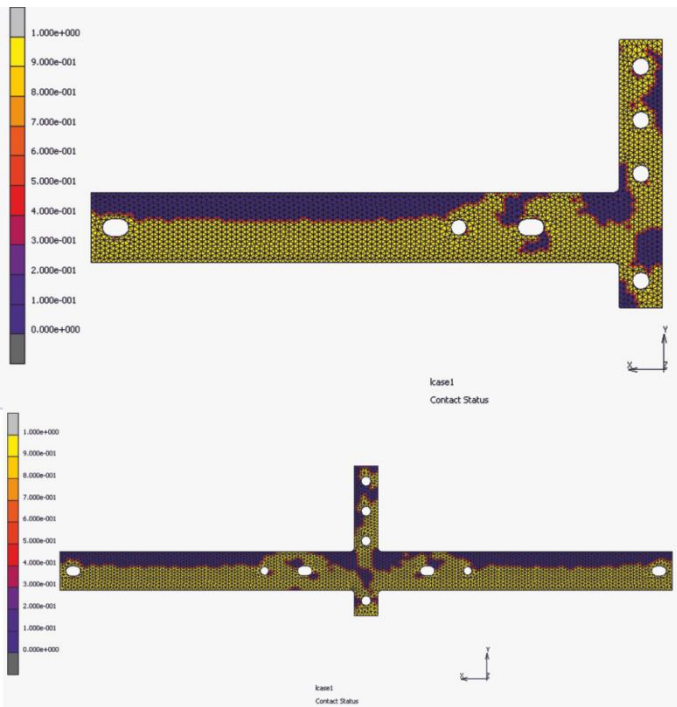

Figure 6. Numerical results – contact status

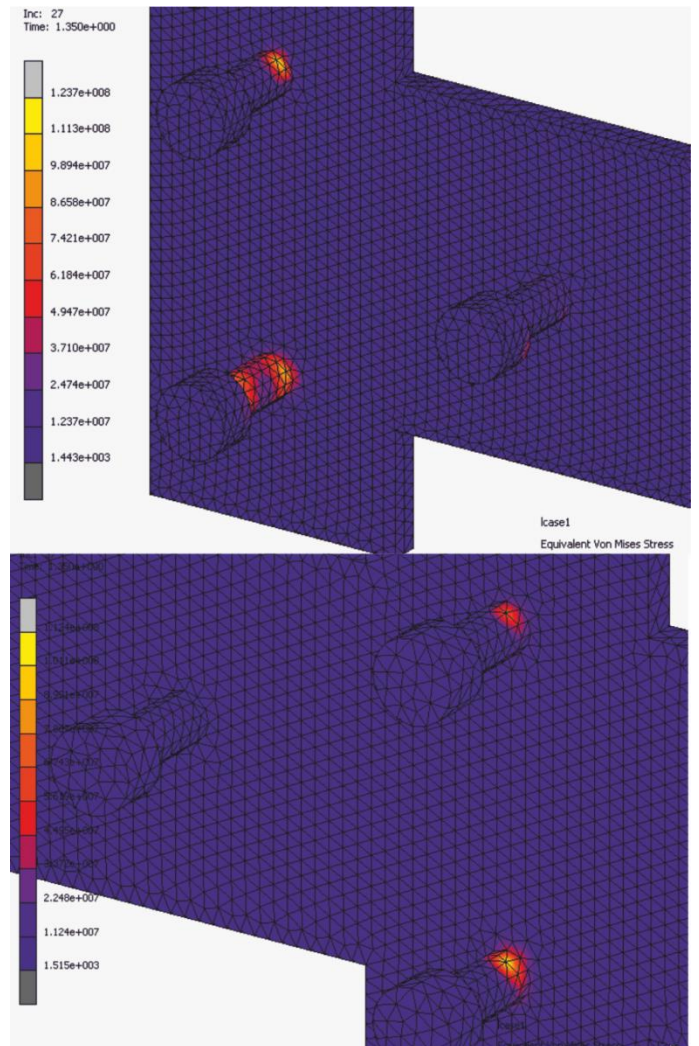

Figure 8. Numerical results – HMH stresses in bolts

The maps of equivalent von Mises (Huber–Mises–Hencky, HMH) stresses are shown in Figure. 7. The model_1 results in the maximum HMH stress equal 106 MPa, the model_2 responds with the 97 MPa value. The maximum stress areas appear on the steel console in its connection with the frame. The maximum stress in the stainless steel cross-shaped window panel supports does not exceed the limit specified in Table 1. Thus the elements meet the ULS requirements.

The stresses in bolts are also verified. The maps of HMH stresses for these elements are shown in Figure 8. It can be shown that the maximum HMH stresses are approximately equal to 123.7 MPa for model_1 with a single window panel support and 112.4 MPa for model_2 with double window panel supports. These values did not exceed the stress limits for the austenitic stainless steel bolts of grade A2 property class 70.

3 CONCLUSIONS

The study investigates the behaviour of stainless steel cross-shaped window panel supports. A modern FEM software equipment allows for different variants of advanced numerical simulations. Such numerical simulations are necessary before the extraordinary design solutions are applied.

The research program completed by the author for the construction of mullion-transom wall system with additional stainless steel elements allows for a proper reorganization of the behaviour of cross-shaped window panel supports. The investigation confirms that the quality of the stainless steel cross-shaped window panel supports, equipment and systems is sufficiently high, meeting the UTS and SLS requirements.

RERERENCES

EN 1993-1-4: 2006. Eurocode 3 – Design of steel structures – Part 1-4: General rules – Supplementary rules for stainless steels.

User Documentation, Marc® 2016 Volume B
https://simcompanion.mscsoftware.com/infocenter/index?page=content&id=DOC11102&cat=MARC_DOCUMENTATION_2016&actp=LIST

