

doi:10.15199/48.2018.11.14

# Programmable dynamically changing RC model for evaluation of Dynamic EIS methods and instrumentation

**Abstract.** The paper concerns the RC equivalent circuit of electrochemical cell with the impedance changed during the experiment. The model was constructed using the digital potentiometers controlled by the microcontroller. This solution allows to control the model impedance by the software means. By creating adequate changes of the impedance spectrum as a time function, the different impedance measurement method can be tested to find out the limitation of each method as well as to test the instrumentation.

**Streszczenie.** Przedmiotem artykułu jest model układu elektrochemicznego, którego impedancja jest zmieniana w czasie w sposób kontrolowany programowo. Do konstrukcji modelu wykorzystano potencjometry cyfrowe sterowane mikrokontrolerem. Odpowiednie ukształtowanie zmian widm impedancyjnych w funkcji czasu (impedancjogramów) pozwala na ustalenie ograniczeń różnych metod pomiaru impedancji. (**Programowalny model RC o zmiennych parametrach do badania metod dynamicznej spektroskopii impedancyjnej**).

**Keywords:** dynamic electrochemical impedance spectroscopy, instantaneous impedance spectra, impedance measurement

**Słowa kluczowe:** dynamiczna elektrochemiczna spektroskopia impedancyjna, impedancjogramy, pomiary impedancji

## Introduction

Impedance spectroscopy [1] is a commonly used diagnostic and research tool in many areas of science and technique, it means in electrochemistry [2], materials engineering [3], anti-corrosion protection [4], biochemistry [5] and medicine [6] and many others. Impedance spectroscopy consists of two phases: first – measurement one – impedance characteristic (spectrum) of the tested object is acquired as a function of the frequency (Fig. 1a), second – analytical one – the state of the object can be determined either directly on the basis of the impedance spectrum or on the basis of the model parameters identified thanks to the measured impedance spectrum of the object under test.

For classical impedance spectrum measurement technique it is necessary to assume stationary or quasi-stationary condition – it is required that the tested object state is not changing or at least is not changing during the experiment. The real-life objects, e.g. electrochemical cells, due to its nature, usually do not fulfill even quasi-stationarity condition. This leads to wide interest in methods allowing to monitor the impedance spectrum changes as a function of time [7-9]. The exemplary instantaneous impedance spectra are shown in Fig. 1b. The graph allows to visualize the impedance spectrum changes during the following stages of the tested object life.

The graph axis marked with „serie” in Fig. 1b can be scaled using time units and the distances between respective spectra depends on the repetition time of the spectrum measurement. The impedance spectrum acquisition method has a meaningful influence on the minimal distance between respective spectra. If the impedance spectrum is measured using a classical impedance analyzer – step by step for each frequency in the spectrum – the measurement time will be extended significantly. Due to this fact, there is a need of methods allowing to shorten the measurement time [10], or even „one-shot” measurement methods making possible to acquire the whole impedance spectrum in a single step experiment, e.g. during the single excitation of the object using signal with the arbitrary designed shape.

In the paper, Authors present the testing tool for such type methods – the object model with impedance spectrum changed during the experiment. The object changes are controlled by software, with the aid of digital potentiometers controlled by the microcontroller.

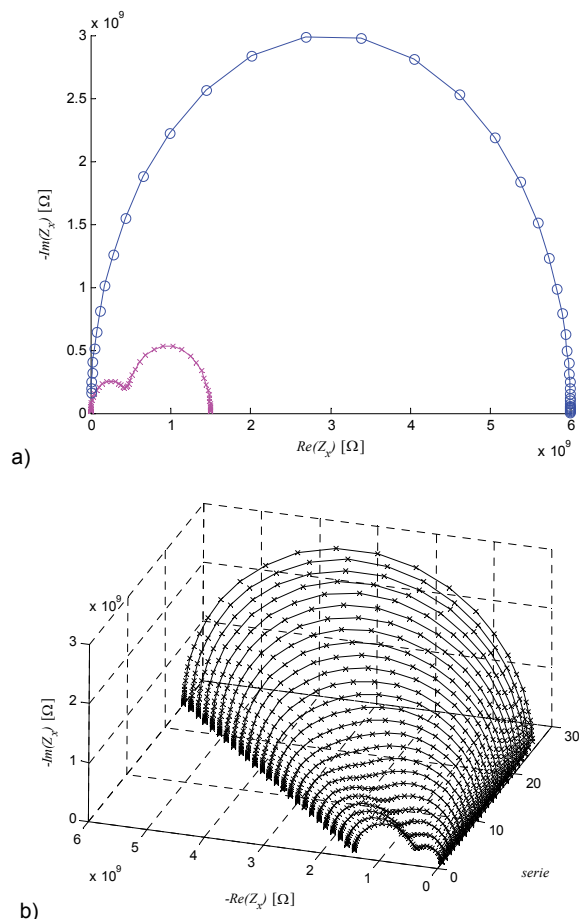

Fig. 1. Exemplary: a) impedance spectrum, b) instantaneous impedance spectra

## The object model with impedance spectrum changed during the experiment

DS1267B-100 [11] integrated circuit was used for the model construction. The circuit contains two, independently controlled digital potentiometers. The potentiometer resistance value is programmed using 8-bit value and can be change in the range starting from ca. 1-2 kΩ (defined in the circuit datasheet [11] as a „wiper resistance”) up to

100 kΩ. The connection diagram of the object model (Baunier model) is shown in Fig. 2a. The resistors R2 and R3 are realized in a form of digital potentiometer components.

The potentiometer integrated circuit is powered using +/- 5 V voltage generated with isolated DC/DC converter from 5 V obtained from USB. The potentiometer supply voltage limits the range of excitation signal amplitude for the tested object to the presented value. Usually, this is no problem as electrochemical objects require measurements with smaller than 100 mV excitation due to the object non-linearities.

The microcontroller controls resistance change of the potentiometers by sending current settings using SPI interface isolated using MEMS isolators.

The model has built-in several modes of operation presented in Table 1. The mode selection and the model parameters programming is performed by the user using PC software, which can communicate with the microcontroller via USB interface.

Depending on the selected mode of operation, it is possible to set the following parameters:

- the repetitions number of the resistance change cycle,
- the number of steps in a single cycle,
- the duration time of the single step,
- the repetition time of the cycle (if more than one),
- the starting values ( $R_{2\text{ START}}$  and  $R_{3\text{ START}}$ ) and the stop values ( $R_{2\text{ STOP}}$  and  $R_{3\text{ STOP}}$ ) of each resistance,
- the direction of each resistance change.

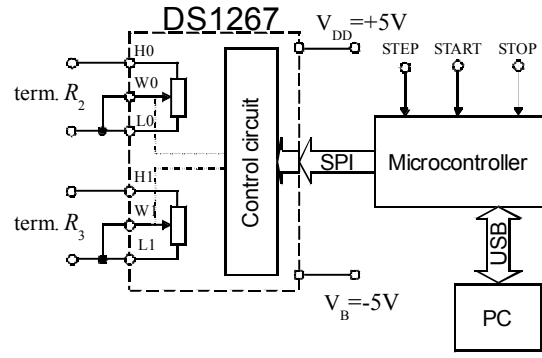
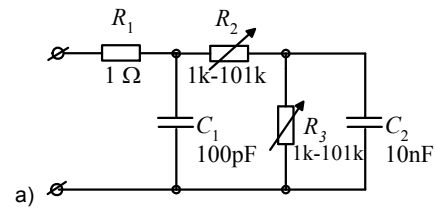

Fig. 2. Object model with impedance varying in time: a) Equivalent circuit, b) the realization of the resistive components with the aid of digital potentiometer controlled by microcontroller

Table 1. Working modes of the object model with impedance spectrum changed during the experiment

Mode	Mode name	Description
0	Linear change of $R_2$	Change $R_{2\text{ START}} \Rightarrow R_{2\text{ STOP}}$ , $R_3 = \text{const}$
1	Linear change of $R_3$	Change $R_{3\text{ START}} \Rightarrow R_{3\text{ STOP}}$ , $R_2 = \text{const}$
2	Linear change of $R_2$ and $R_3$	Change $R_{2\text{ START}} \Rightarrow R_{2\text{ STOP}}$ and $R_{3\text{ START}} \Rightarrow R_{3\text{ STOP}}$
3	Linear anti-change of $R_2$ and $R_3$	Change $R_{2\text{ START}} \Rightarrow R_{2\text{ STOP}}$ and $R_{3\text{ STOP}} \Rightarrow R_{3\text{ START}}$
4	Step change of $R_2$	$R_2 = R_{2\text{ START}}$ at $t = (0, t_{p2})$ and $R_2 = R_{2\text{ STOP}}$ at $t = (t_{p2}, t_{k2})$ , $R_3 = \text{const}$
5	Step change of $R_3$	$R_3 = R_{3\text{ START}}$ at $t = (0, t_{p3})$ and $R_3 = R_{3\text{ STOP}}$ at $t = (t_{p3}, t_{k3})$ , $R_2 = \text{const}$
6	Step change of $R_2$ and $R_3$	$R_2 = R_{2\text{ START}}$ at $t = (0, t_{p2})$ and $R_2 = R_{2\text{ STOP}}$ at $t = (t_{p2}, t_{k2})$ $R_3 = R_{3\text{ START}}$ at $t = (0, t_{p3})$ and $R_3 = R_{3\text{ STOP}}$ at $t = (t_{p3}, t_{k3})$
7	Arbitrary change of $R_2$	$R_2(t_n) = R_{2\text{ LIST}}[n]$ , $R_3 = \text{const}$
8	Arbitrary change of $R_3$	$R_3(t_n) = R_{3\text{ LIST}}[n]$ , $R_2 = \text{const}$
9	Arbitrary change of $R_2$ and $R_3$	$R_2(t_n) = R_{2\text{ LIST}}[n]$ and $R_3(t_n) = R_{3\text{ LIST}}[n]$

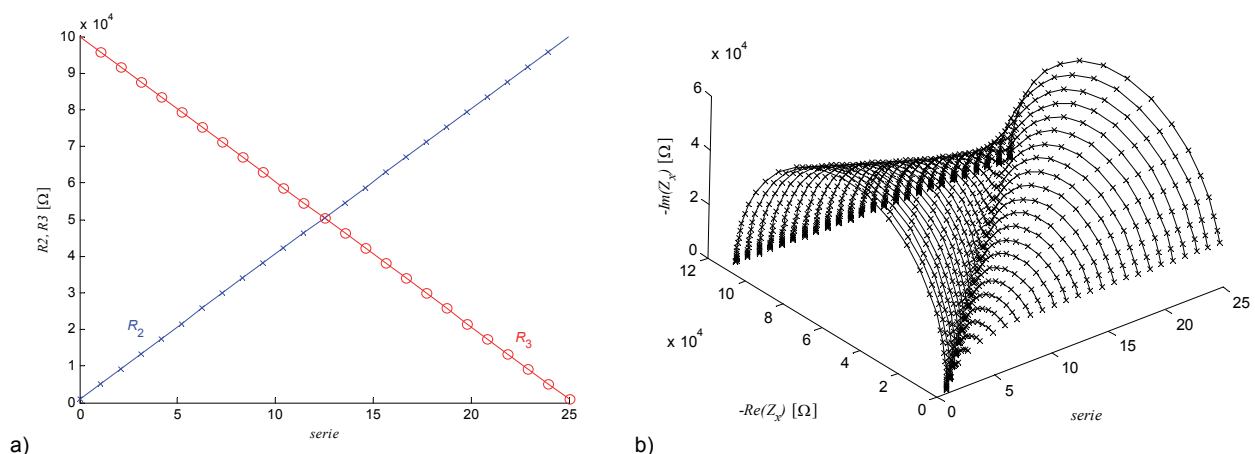

Fig. 3. Exemplary usage of model with impedance changing in time: a) resistor parameters change in mode 3, b) resulting DEIS diagram

Figure 3a presents exemplary changes of the potentiometers resistance change for mode 3 and for the following set of parameters:  $R_{2\text{ START}} = R_{3\text{ START}} = 1\text{ k}\Omega$ ,

$R_{2\text{ STOP}} = R_{3\text{ STOP}} = 100\text{ k}\Omega$ . Figure 3b presents the resulting instantaneous impedance spectra for the model presented in Fig. 2a and for parameters changing according to Fig. 3a.

The impedance spectrum frequency range (1 Hz – 100 kHz) was selected in order to map the whole range of the model impedance changes.

For arbitrary change modes (modes 7-9) it is necessary to send to microcontroller the list of values for the selected resistor. In the consecutive steps of the cycle, the defined resistance values are set for the selected potentiometer, allowing to obtain practically any required shape of the resistance change.

After sending operational mode and parameters, the connection to the computer is no longer necessary – the change cycle (cycles) triggering can be performed either from personal computer or via digital trigger input of the microcontroller (START input). Similarly, the resistance changes can be clocked by internal microcontroller clock or by external digital signal (STEP input).

Thanks to STEP input usage, it is possible to join the impedance changes to the impedance measurement process (e.g. the model parameter change can be triggered after the impedance analyzer finishes the impedance spectrum acquisition).

The digital input STOP allows to stop the cycle at the required time moment.

### The model testing with Goertzel filter-bank

The model with changing impedance was firstly introduced in [12] and then further developed. The construction of the model was extended by adding the isolation between the digital potentiometer and the microcontroller to minimize the noises induced from PC.

The model is intended to be used for testing different methods of Dynamic Electrochemical Impedance Spectroscopy (DEIS). DEIS methods can be counted into JTFA (Joint Time-Frequency Analysis) methods.

Generally, the idea of such methods lies in continuous (or repeated sequentially) excitation with the signal of complex spectrum e.g. multi-sine, square or Gaussian impulse, chirp, white noise and continuous acquisition of the response signals.

Then, the response signal have to be analyzed using the analysis technique which can be counted to one of three groups:

- Short-Time Discrete Fourier Transform (ST-DFT);
- Filter-bank (e.g. Goertzel FB);
- Higher order transformations (Wigner-Ville, wavelet).

The first group divides the whole acquisition time to smaller parts (windowing) and then analyzes each part separately using classical Fourier analysis. The analyzed signal windows can be overlapping or non-overlapping. Depending on the overlapping ratio, the response can be more or less smooth. When using wide frequency range the window size must be carefully selected to correctly cover the whole frequency range and to avoid spectrum leakage.

The last group of higher order transformations is very useful for detecting anomalies in the searched signals but for impedance calculation it has lesser usage due to lack of direct physical interpretation.

The filter-bank approach looks very interesting due to the fact the filter output signal is produced every sample. It is especially useful for continuous monitoring of signal changes (in this case impedance).

The model described in the previous section was used for evaluation of the digital implementation of the filter-bank. The Goertzel algorithm [13] was used due to its efficiency and low computational effort and memory usage.

Figure 4 presents results of testing Goertzel filter-bank implementation using the idea of object model with programmably controlled impedance characteristic.

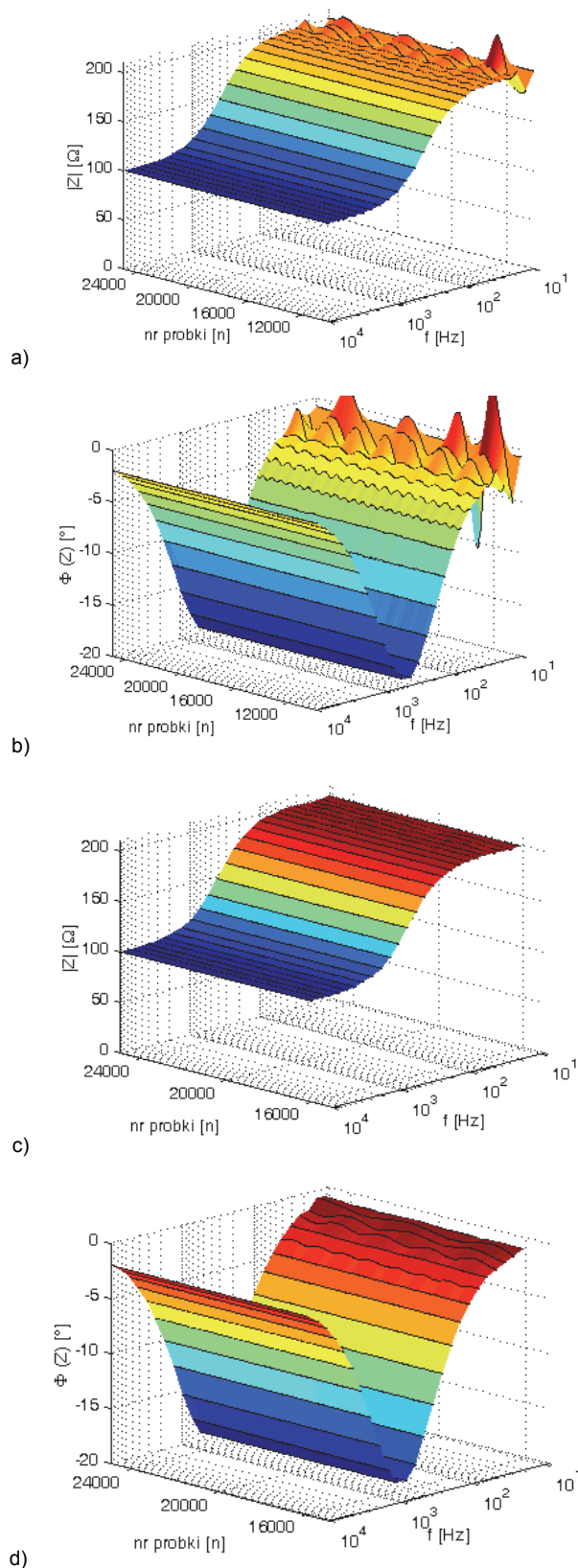

Fig.4. The results of the testing of Goertzel filter-bank implementation using the developed object model with the impedance changing in time with arbitrary mode: a) and b) the case for non-correctly set filter coefficients c) and d) the case for correctly set filter coefficients; a) and c) modulus of the impedance; b) and d) argument (phase) of the impedance

Two cases are presented: the first one (Fig. 4a and b) where the filter coefficients were not-correctly set and the second one (Fig. 4c and d) where the filter coefficients were correctly set. The impedance is presented as the modulus (Fig. 4a and c) and the argument - phase angle (Fig. 4. b and d).

The testing system presented in Fig. 5 was built using DAQ card (NI USB-6251), the home made input circuitry and the developed dedicated software. The software controls generation of multi-sine signal and acquisition of the response signals proportional to voltage across and current through the object.

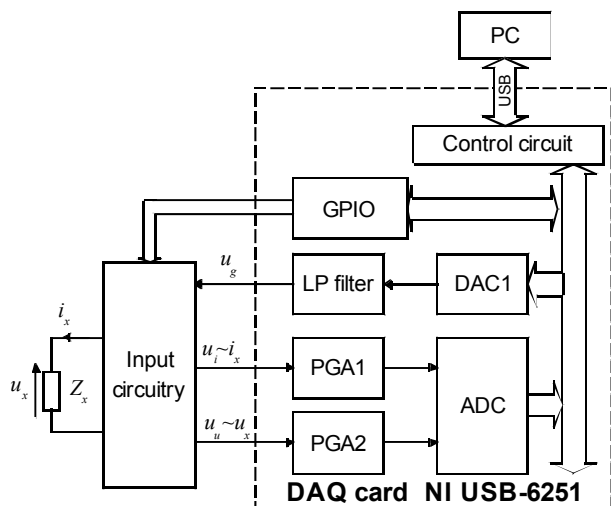

Fig. 5. The measurement system used for testing the Goertzel filter-bank method with the aid of the developed object model

The software also calculates, sample by sample, the response for each channel of the filter-bank, separately for the voltage signal and for the current signal. Using both these informations the impedance response is calculated and updated after each acquired sample and for each frequency the filter-bank is designed for.

## Conclusions

The paper presents the idea and the construction of the object model with impedance change in time controlled by the software. The main application of the developed object is testing and evaluation of method and instrumentation for Dynamic Electrochemical Impedance Spectroscopy (DEIS).

Thanks to the use of, beside RC components with constant values, digital potentiometers controlled by the microcontroller, it is possible to shape the characteristic and range of changes by the software. It means, that the user can control the model impedance change according to the user requirements. In the view of testing measurement methods, it allows to test the selected aspects and problems of dynamic impedance measurements.

The model will be used for testing dynamic impedance measurement methods the Authors are currently working on especially those based on excitation with different shape pulses (sinc, square, Gaussian).

**Authors:** dr hab. inż. Grzegorz Lentka, prof. nadzw. PG, e-mail: [lentka@eti.pg.edu.pl](mailto:lentka@eti.pg.edu.pl); mgr inż. Dariusz Palmowski, e-mail: [palmowski@eti.pg.edu.pl](mailto:palmowski@eti.pg.edu.pl); Faculty of Electronics, Telecommunications and Informatics, Department of Metrology and Optoelectronics, dr hab. inż. Paweł Ślepski, Faculty of Chemistry, Department of Electrochemistry, Corrosion and Materials Engineering, Gdansk University of Technology, ul. Narutowicza 11/12, 80-233 Gdańsk.

## REFERENCES

- [1] Barsoukov E., Macdonald J. R., Impedance Spectroscopy: Theory, Experiment and Applications, John Wiley & Sons, 2005
- [2] Ślepski P., Darowicki K., Janicka E., Lentka G., A complete Bilayer analysis of electrochemical cells used as energy sources, *Journal of Solid State Electrochemistry*, Vol. 16, Iss. 11, 3539-3549, 2012
- [3] Srinivas K., Sarah P., Suryanarayana S. V., Impedance spectroscopy study of polycrystalline  $\text{Bi}_6\text{Fe}_2\text{Ti}_3\text{O}_{18}$ , *Bulletin of Material Science*, Vol. 26, 247-253, 2003
- [4] Skale, S., Doleżek, V., Slemnik, M., Electrochemical impedance studies of corrosion protected surfaces covered by epoxy polyamide coating systems, *Progress in Organic Coatings*, Vol. 62, No. 12, 2456-2460, 2008
- [5] Valincius G., Mickevicius M., Penkauskas T., Jankunec M., Electrochemical Impedance Spectroscopy of Tethered Bilayer Membranes: An Effect of Heterogeneous Distribution of Defects in Membranes, *Electrochimica Acta*, DOI: 222. 10.1016/j.electacta.2016.11.05, 2016
- [6] Xu Z., Neoh K. G., Kishen A., Monitoring acid-demineralization of human dentine by electrochemical impedance spectroscopy, *Journal of Dentistry*, 36 (12), 1005-1012, 2008
- [7] Wysocka J., Krakowiak S., Ryl J., Darowicki K.: Investigation of the electrochemical behaviour of AA1050 aluminium alloy in aqueous alkaline solutions using Dynamic Electrochemical Impedance Spectroscopy, *Journal of Electroanalytical Chemistry*, Vol. 778, 126-136, 2016
- [8] Ryl J., Bogdanowicz R., Ślepski P., Sobaszek M., Darowicki K., Dynamic Electrochemical Impedance Spectroscopy (DEIS) as a Tool for Analyzing Surface Oxidation Processes on Boron-Doped Diamond Electrodes, *Journal of Electrochemical Society*, Vol. 161, No 6, 359-364, 2014
- [9] Srinivasan A., Kwang S. S., Rajendran N.: Dynamic electrochemical impedance spectroscopy (DEIS) studies of AZ31 magnesium alloy in simulated body fluid solution, *RSC Advances*, No. 4, 27791-27795, 2014
- [10] Hoja J., Lentka G.: Szybkie metody spektroskopii impedancyjnej, rozdział w: Problemy metrologii elektronicznej i fotonicznej, Nr 4, red. J. Mroczka, Wrocław: Oficyna Wydawnicza Politechniki Wrocławskiej, 201-252, 2011
- [11] Maxim Integrated: DS1267B Dual Digital Potentiometer Datasheet, 2014
- [12] Lentka G., Ślepski P., Palmowski D., Wykorzystanie potencjometrów cyfrowych do testowania metod dynamicznej spektroskopii impedancyjnej, XII Konferencja Naukowa, Systemy Pomiarowe w Badaniach Naukowych I w Przemysle (2018), s.111-114
- [13] Lentka G., Niedostatkiwicz M., The Goertzel filter-bank usage in the non-stationary impedance measurement, *Proc. 13th Int. Symp. on Meas. for Research and Industry Applications IMEKO TC-4*, Athens 2004, Vol. 1, 110-115