

# Large deformation modelling of CPT probing in soft soil—pore water pressure analysis

J. Konkol & L. Bałachowski

*Faculty of Civil and Environmental Engineering, Gdańsk University of Technology, Gdańsk, Poland*

**ABSTRACT:** This paper presents the results of finite element modelling with Updated Lagrangian formulation of the Cone Penetration Test in soft soil deposit located in Jazowa, Poland. The numerical calculations are carried out for homogenous, normally consolidated, organic soil layer. The Modified Cam Clay constitutive model for soft soil and Coulomb model for interface are used. The study compares the registered pore water pressure distributions for type-2 piezocone observed during in-situ penetration and corresponding numerical model. The numerical dissipation test is carried out and the results are confronted with in-situ registered data. The influence of orthotropic soil hydraulic conductivity on pore water pressure development at shoulder filter element during dissipation tests is examined. Finally, the distribution of pore water pressures around the piezocone obtained from numerical simulations is compared with high quality literature database.

## 1 INTRODUCTION

Piezocone is one of the most widely and successfully used site investigation tool. It enables to measure the pore water pressure development during cone penetration into the subsoil as well as pore water pressure dissipation at stationary cone position. Dissipation tests are commonly used to estimate the horizontal coefficient of permeability or horizontal coefficient of consolidation. However, the above mentioned variables are usually determined by empirical correlations based on statistical analysis with scatter data and its applicability is often limited (e.g., Robertson et al., 1992).

In recent years, the rapid development of numerical methods introduces the new possibilities in analysis of pore water pressure distributions around the piezocone (e.g., Burns & Mayne, 1998). These studies mainly concern on developing of new methods of coefficient of consolidation estimation (e.g., Chai et al., 2012) or the horizontal coefficient of consolidation determination (e.g., Ansari et al., 2014). The parametric studies which link the coefficient of consolidation with strength and consolidation parameters of the soil have been also carried out (e.g., Mahmoodzadeh et al., 2014). The influence of partial drainage on dissipation curves was also in terms of interests (e.g., Sheng et al., 2014; Ceccato et al., 2016). However, in most of these studies isotropic soil permeability is applied (e.g., Chai et al., 2012, 2014; Ansari et al., 2014; Ceccato et al., 2016). The influence of

orthotropic coefficient of permeability is usually neglected and it is rarely investigated.

In this paper the case study of numerical modelling of piezocone penetration and dissipation test for soft soil deposit located in Jazowa, Northern Poland is presented. In the first part of this paper the applicability of numerical methods in terms of Updated Lagrangian (UL) for CPT penetration prediction is shown. Next, the influence of anisotropy of the coefficient of permeability on dissipation curve is investigated. On the basis of numerical tests the empirical correlation for horizontal coefficient of permeability presented by Robertson (2010) is calibrated on the purpose of Jazowa clayey mud case. Finally, the pore water pressure distributions obtained from numerical calculations for Jazowa site are compared with available database.

## 2 REFERENCE FIELD TESTING SITE

The Jazowa testing site is chosen as the reference site and it is located in Vistula Marshlands, 50 km southeast of Gdańsk, Poland, within the S7 highway. Jazowa testing site is supervised by Gdańsk University of Technology and Menard Polska under the cooperation within the National Centre of Research and Development grant. For purpose of this paper 14 piezocone penetration tests (CPTu) and 4 dissipation tests are used as reference field tests. The authors decide to model

Table 1. Jazowa clayey mud parameters.

Parameter	Symbol	Value	Unit
Soil dry bulk density	$\rho_d$	1.074	g/cm <sup>3</sup>
Void ratio	$e_0$	1.416	–
Coefficient of permeability	$k$	$2.74 \times 10^{-10}$	m/s
Shear modulus	$G$	4000	kPa
Undrained shear strength obtained in UU test	$c_{u,UU}$	29	kPa
Logarithmic elastic modulus	$\kappa$	0.0359	–
Logarithmic plastic modulus	$\mu$	0.1890	–
Mean preconsolidation stress	$p_c$	55	kPa
Stress ratio in $p$ - $q$ plane	$M$	1.5	–
Lateral earth pressure at rest coefficient	$K_0$	0.54	–
Overconsolidation ratio	OCR	1.0	–

numerically the CPTu probing from 8 to 9 m depth below ground level and to perform dissipation test at the 9 m depth, where 4 field reference dissipation tests have been carried out.

The soil parameters used in the numerical study are based on laboratory testing, see Table 1. The initial soil conditions in terms of earth pressure at rest coefficients are determined from 8 flat dilatometer test (DMT) soundings that have been carried out at Jazowa site. The coefficient of permeability has been estimated from isotropically consolidated soil sample in triaxial apparatus. This value has been verified using dissipation curves and Robertson formula (2010):

$$k_h = (1.67 \times 10^{-6}) \times 10^{(1 - \log(t_{50}))} \times \gamma_w / (Q_t^2 \times \sigma'_{v0}) \quad (1)$$

where  $k_h$  = horizontal coefficient of permeability;  $t_{50}$  = time corresponding to 50% of consolidation;  $\gamma_w$  = water unit weight;  $Q_t = (q_t - \sigma'_{v0}) / \sigma'_{v0}$ ;  $q_t$  = corrected cone resistance;  $\sigma'_{v0}$  = total vertical stress; and  $\sigma'_{v0}$  = effective vertical stress.

Equation 1 returns  $k_h = 3.6 \times 10^{-10}$  m/s for Jazowa CPTu dissipation and probing data.

### 3 NUMERICAL MODEL DEVELOPMENT

The numerical calculations are performed with UL formulation as it is implemented in Abaqus 6.14. The UL formulation is provided in Abaqus Standard when the nonlinear geometry option (NL-GEOM) is toggled on. UL formulation uses the reference domain from the previous time increment, which facilitates the analysis when large deformations occur (e.g., Mahmoodzadeh et al., 2014). The axisymmetric soil domain is 2.2 m high and 1.0 m wide and it is discretized with 6936 quadratic, second order elements with reduced integration, see

Figure 1. The cone is pre-bored at the depth of 5 cm in the soil and it is jacked with standard velocity of 2 cm/s using zipper type technique. In this technique, the rigid cone is connected with tube that is in frictionless contact with soil domain and which moves downward with cone (Mabsout & Tassoulas, 1994). The overburden pressure and the pore water pressure are applied to simulate in-situ conditions. The penetration stroke is 1 m and the final level corresponds to approximately 9 m depth in field. Then, the numerical dissipation test is carried out.

The Modified Cam-Clay (MCC) model is used to simulate the soil behavior with the parameters presented in Table 1. However, some minor changes have been applied and they are discussed below. The soil parameters calibration procedure on TX samples suggests the reduction of plastic surface size on the wet side of critical state line (CSL) by 30% (Das-sault Systèmes, 2014). The plastic surface in  $\pi$ -plane is not modified and is kept as a circle. The coefficient of permeability is increased to  $k = 2 \times 10^{-9}$  m/s due to isotropic consolidation calibration tests. However, this modification still preserves the undrained conditions which are commonly accepted for  $k \leq 10^{-8}$  m/s for clayey soils (e.g., Ceccato et al., 2016; Suzuki, 2015). As the piezocone is pressed into the subsoil with much higher rate than it is achieved during standard Unconsolidated Undrained (UU) triaxial compression tests, the MCC model must also reflect the rate dependency. Kulhawy and Mayne (1990) have shown that the undrained shear strength increases with the strain rate after formula:

$$c_u = c_{u0} \times (1 + 0.1 \times \log(\dot{\epsilon})) \quad (2)$$

where  $c_u$  = actual undrained shear strength;  $c_{u0}$  = reference undrained shear strength corresponding to strain rate of 1%/h; and  $\dot{\epsilon}$  = strain rate.

Preliminary laboratory testing of Jazowa clayey mud has confirmed the rate dependency of the material. For strain rate of 1%/h the reference  $c_{u0}$  is equal to 25 kPa. According to Equation 2, the  $c_u$  obtained in UU triaxial test with  $\dot{\epsilon} \approx 60\%/h$  should be equal to 29.5 kPa and similar value was measured directly in laboratory, see Table 1. For CPTu penetration the strain rate is approximately 200000%/h, which results in  $c_u = 1.5 c_{u0}$ . Consequently, the MCC parameters should simulate the undrained behavior corresponding to  $c_u$  equal to 37.5 kPa. To achieve this goal only the preconsolidation pressure  $p'_c$  will be modified. Worth (1984) have shown that  $c_u$  can be derived from MCC parameters when the same plastic surface size for wet and dry side of the CSL is used. However, Worth's derivation can be easily expanded for different sizes of plastic surfaces on the dry and wet side of CSL (Konkol, 2017) and consequently, the preconsolidation pressure that supports the corresponding  $c_u$  for undrained shearing can be defined as:

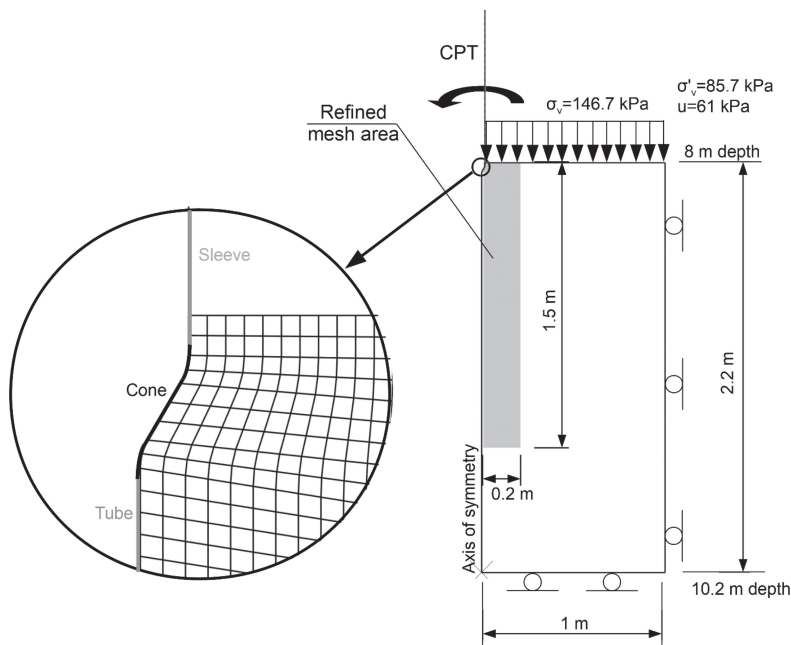

Figure 1. UL model geometry and boundary conditions.

$$p'_c = \left( \frac{2 \times (1 + \beta) \times c_u}{M} \times ((1 + \beta) \times p'_0)^{-\kappa/\lambda} \right)^{\frac{\lambda}{\lambda - \kappa}} \quad (3)$$

where:  $p'_c$  = preconsolidation pressure corresponding to  $c_u$ ;  $M$  = stress ratio in  $p'$ - $q$  plane;  $\beta$  = size of the Figure 1. UL model geometry and boundary conditions plastic surface on the wet side of CSL;  $c_u$  = undrained shear strength;  $p'_0$  = initial mean effective stress;  $\kappa$  = logarithmic elastic modulus; and  $\lambda$  = logarithmic plastic modulus.

To provide the  $c_u$  equal to 37.5 kPa, the Equation 3 returns  $p'_c = 82$  kPa. Consequently, this value is used in the numerical model to satisfy the shear rate influence instead of the value provided in Table 1. The last modification of the parameters is related to large deformation problem where rigidity index  $G/c_u$  is usually around 50 (Vardanega & Bolton, 2013). To satisfy this condition  $G = 2000$  kPa is assumed in numerical models.

The last modelling issue is the interface behavior between cone and the soil. In Abaqus tangential contact between soil and cone is used in terms of effective stresses. This is a widely used assumption as a smooth contact between water and cone is considered. However, this implies a problem in modelling when undrained shearing occurs at the interface and where adhesive contact should be applied. Laboratory direct shear tests on smooth steel–Jazowia clayey mud interface suggest the effective angle of

interface friction  $\delta_f$  as equal to  $10^\circ$  and adhesion  $\alpha \approx 0.36$ . Assuming  $c_u = 37.5$  kPa, the limit interface shear stress is equal to 13.5 kPa. The frictional contact have been applied with Coulomb friction coefficient of 0.176 (corresponding to  $\delta_f = 10^\circ$ ) in order to accurately model the cone–soil interface during penetration. To include the adhesion contact, the maximum allowable shear stress at the interface is limited to 13.5 kPa. During CPTu dissipation test, no shear stress limit is defined due to drained analysis.

In this paper the results of 5 cases are presented and the testing program is summarized in Table 2. Test-1 (default) is preliminary calculation with isotropic soil hydraulic conductivity. In Test-2 to Test-5 the orthotropic coefficients of permeability are applied. The boundary value of  $k_h = 10^{-8}$  m/s is chosen to maintain undrained condition during piezocone penetration. The tested ratios of coefficients of permeability are in agreement with available databases for cohesive soils (e.g., Robertson et al., 1992).

## 4 RESULTS ANALYSIS

### 4.1 Field measurements versus numerical ones

Due to undrained penetration of piezocone all tests show almost the same response during probing. The numerical results of corrected cone resistance  $q_c$ , sleeve friction  $f_s$  and pore water pressures

Table 2. Numerical testing program for Jazowa clayey mud piezocone.

Test no	Soil coefficient of permeability [m/s]		$k_h/k_v$
	Vertical	Horizontal	
1	$2 \times 10^{-9}$	$2 \times 10^{-9}$	1
2	$2 \times 10^{-9}$	$4 \times 10^{-9}$	2
3	$2 \times 10^{-9}$	$6 \times 10^{-9}$	3
4	$2 \times 10^{-9}$	$8 \times 10^{-9}$	4
5	$2 \times 10^{-9}$	$10^{-8}$	5

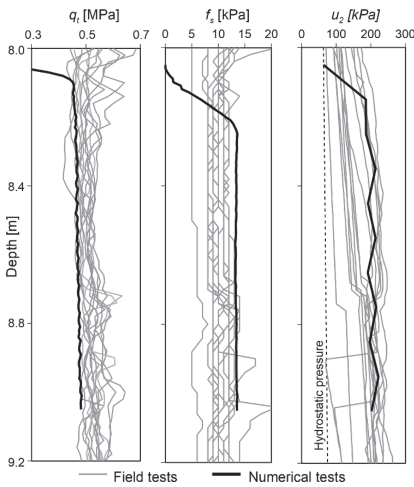

Figure 2. Numerical results of CPTu penetration compared with in situ measurement.

$u_2$  are compared with the field measurements in Figure 2. The numerical readings start from 8.05 m depth due to cone pre-installation. The pore water pressure reading cannot be obtained automatically from numerical model. As a result, the  $u_2$  value is read out with 10 cm interval manually at mesh node in the vicinity of filter location. As can be seen, very satisfactory results have been achieved. The numerically obtained  $q_t$  is the lower bound of the field measurement while  $f_s$  is the upper bound. The previous research on numerical modelling of penetration has shown that  $q_t$  is sensitive to rigidity index  $G/c_u$  (e.g., Van den Berg, 1994). As  $c_u$  cannot be changed due to modelling assumptions, the perfect fit for  $q_t$  authors achieved when  $G \approx 3000$  kPa which corresponds to  $G/c_u = 80$ . The friction sleeve is constant and equal to 13.5 kPa. This is in agreement with the assumption presented in section 3, where the shear stresses at the interface have been limited to this value. However, the field tests at Jazowa site with different penetration rates suggest that rate dependency on

interface is not so obvious and further studies in this area are required. Consequently, the assumption of rate dependency of interface shear strength used in section 3 may be questionable. The field measurement of  $u_2$  is characterized by a large scatter which may be caused by many factors (Campanella et al., 1986). However, very satisfactory fit between field measurement and numerical results has been achieved in terms of  $u_2$  distributions, especially for the last 40 cm of probing. Consequently, it can be assumed that the numerical modelling in a very accurate way reflects the field measurements performed at Jazowa site.

#### 4.2 Influence of the permeability coefficient anisotropy

The application of the orthotropic coefficient of permeability results in a faster pore water pressure dissipation and a lower maximum calculated values of  $u_2$ , see Figure 3. The dissipation curves presented in Figure 3 prove that the horizontal coefficient of permeability plays a key role in pore water pressure dissipation behavior and even slight deviation in  $k_h/k_v$  from isotropic distribution results in visible reduction of dissipation time. However, the rate of this process decreases with increasing  $k_h/k_v$ . The  $k_h/k_v$  between 4 and 5 seems to reflect the in-situ conditions. Moreover, the conducted UL tests allow for the calibration of Robertson (2010) formula in terms of horizontal coefficient of permeability. The back calculation reveals the conversion of empirical factor  $1.67 \times 10^{-6}$  to  $4.0 \times 10^{-5}$ . Consequently,  $k_h$  for Jazowa site can be calculated as:

$$k_h = (4 \times 10^{-5}) \times 10^{(1 - \log(t_{50}))} \times \gamma_w / (Q_t^2 \times \sigma'_{v0}) \quad (4)$$

where  $k_h$  = horizontal coefficient of permeability;  $t_{50}$  = time corresponding to 50% of consolidation;  $\gamma_w$  = water unit weight;  $Q_t = (q_t - \sigma'_{v0}) / \sigma'_{v0}$ ;  $q_t$  = corrected cone resistance;  $\sigma'_{v0}$  = total vertical stress; and  $\sigma'_{v0}$  = effective vertical stress.

Equation 4 returns  $k_h = 8.6 \times 10^{-9}$  m/s for Jazowa CPTu data. The results of calibration are similar to the results of numerical research on normally consolidated soil presented by Ansari et al. (2014). According to the procedure described by Ansari et al.  $k_h = 9.4 \times 10^{-9}$  m/s has been obtained.

#### 4.3 Pore water pressure distribution around the piezocone

The distribution of pore water pressures around the cone and sleeve at the end of piezocone penetration has been compared with the available database of pore water pressure measurements in soft, normally consolidated soils (Chen & Mayne, 1994). The four possible filter locations have been

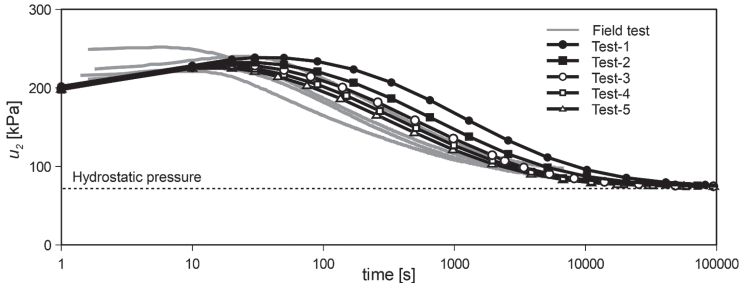

Figure 3. Numerical results of dissipation tests versus field measured ones.

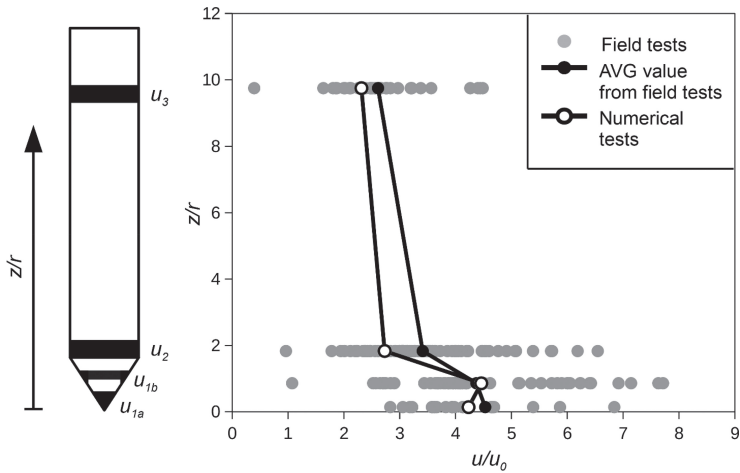

Figure 4. Pore water pressure distribution around the piezocone obtained from numerical tests and compared with database (Chen & Mayne, 1994).

considered in numerical models to provide sufficient comparison, see Figure 4. As one can see, the numerical modelling results of CPTu penetration in Jazowa clayey mud are in the range of other in-situ measurements. Further, the pore water pressures calculated in each filter location in numerical models are similar to the trend outlined by average values from database.

## 5 CONCLUSIONS

The numerical studies performed have shown that UL formulation as it is implemented in Abaqus can be successfully used for the CPTu penetration problem and the two-phase soil model. The satisfactory results achieved with UL formulation and presented in this paper as well as in previous research (e.g., Chai et al., 2012; Mahmoodzadeh et al., 2014) are sufficient to conclude that UL formulation is well-established method for large deformation problems.

The results of numerical analysis of CPTu probing in Jazowa clayey mud have been verified by field tests conducted at the site. Some final remarks about introduced studies can be formulated. Firstly, the simplification in terms of limitation of maximum shear stress at the interface can be used to simulate the adhesive contact for undrained penetration. However, the pure friction contact behavior is based on effective pressures and the change in friction behavior results in practically the same pore water distributions during cone penetration regardless the limit shear stresses at the interface are defined or not. This is proper model response due to smooth steel-water interface. Nevertheless, the laboratory tests on clay-steel interfaces have shown that increasing interface roughness results in increasing pore water pressures at the interface (Tsubakihara & Kishida, 1993). The same mechanism is observed when total stress analysis is used (e.g., Beuth & Vermeer, 2013). Consequently, further studies in this area are required. Secondly, the orthotropic soil hydraulic conductivity strongly



influences the dissipation response measured at  $u_2$  position. The horizontal coefficient of permeability also influences the shape of the dissipation curve as it was shown in Figure 3. However, it was found that dissipation time decrease weakens with increasing  $k_h/k_v$  ratio. Consequently, UL modelling of CPTu can be used as an additional tool to calibrate the orthotropic hydraulic conductivity of soil as it was shown for Jazowa clayey mud. The numerical tests also enable to calibrate and to match the commonly accepted formulas for  $k_h$  estimation to the local soft soil deposits as it has been shown in this paper. Finally, the numerical modelling presents the reasonable values of pore water pressure at  $u_1$  and  $u_3$  positions in accordance to the collected database. Therefore, the  $u_1$  and  $u_3$  pressures obtained from the numerical modelling can be treated as a representative and accurate values for Jazowa clayey mud.

Summing up, the numerical tests performed in this paper have confirmed the applicability of UL formulation. The influence of anisotropy of coefficient of consolidation on the dissipation tests results has been analyzed and the empirical equation for  $k_h$  initially presented by Robertson (2010) has been calibrated for the purpose of Jazowa clayey mud case. Consequently, the advanced numerical methods find its place as an additional tool for more precise geotechnical site investigation.

## ACKNOWLEDGEMENTS

The research is supported by the National Centre for Research and Development grant PBS3/B2/18/2015. The calculations were carried out at the Academic Computer Centre in Gdańsk (CI TASK).

## REFERENCES

- Ansari, Y., Merifield, M. & Sheng, D. 2014. A piezocone dissipation test interpretation method for hydraulic conductivity of soft clays. *Soils and Foundations*, 54(6): 1104–1116.
- Beuth, L. & Vermeer, P.A. 2013. Large deformation analysis of cone penetration in undrained clay. In M.A. Hicks et al. (eds.), *Installation effects in geotechnical engineering, Proc. intern. conf., Rotterdam, The Netherlands, 24–27 March 2013*. London, UK: Taylor & Francis.
- Burns, S.E. & Mayne, P.W. 1998. Monotonic and dilatatory pore-pressure decay during piezocone tests in clay. *Canadian Geotechnical Journal*, 35(6): 1063–1073.
- Campanella, R.G., Robertson, P.K. & Gillespie, D. 1986. Factors affecting the pore water pressure and its measurements around the penetrating cone. In *Proceedings of 39th Canadian Geotechnical Conference*. Ottawa, Canada.
- Ceccato, F., Beuth, L. & Simonini, P. 2016. Analysis of Piezocone Penetration under Different Drainage Conditions with the Two-Phase Material Point Method. *Journal of Geotechnical and Geoenvironmental Engineering*, 140(12): 04016066.
- Chai, J., Hossain, M.J., Carter, J.P. & Shen, S.-L. 2014. Cone penetration-induced pore pressure distribution and dissipation. *Computers and Geotechnics*, 57: 105–113.
- Chai, J., Sheng, D. & Zhu, H. 2012. Coefficient of consolidation from non-standard piezocone dissipation curves. *Computers and Geotechnics*, 41: 13–22.
- Chen, B.S.Y. & Mayne, P.W. 1994. *Profiling the overconsolidation ratio of clays by piezocone tests*. Internal Report GIT-CEEGEO-94-1. Atlanta: Georgia Institute of Technology.
- Dassault Systèmes. 2014. Abaqus 6.14 Documentation.
- Konkol, J. 2017. *Numerical analysis of pile installation effects in cohesive soils*. PhD Thesis. Gdańsk: Gdańsk University of Technology.
- Kulhawy, F.H. & Mayne, P.W. 1990. *Manual on estimating soil properties for foundation design*. Palo Alto, California, USA: Electric Power Research Institute.
- Mabsout, M.E. & Tassoulas, J.L. 1994. A finite element model for the simulation of pile driving. *International Journal for Numerical Methods in Engineering*, 37(2): 257–278.
- Mahmoodzadeh, H., Randolph, M.F. & Wang, D. 2014. Numerical simulation of piezocone dissipation test in clays. *Géotechnique*, 64(8): 657–666.
- Robertson, P.K. 2010. Estimating in-situ soil permeability from CPT & CPTu. In *Proceedings of 2nd International Symposium on Cone Penetration Testing*. Pomona, California, USA: California State Polytechnic University.
- Robertson, P.K., Sully, J.P., Woeller, D.J., Lunne, T., Powell, J.M.M. & Gillespie, D.G. 1992. Estimating coefficient of consolidation from piezocone tests. *Canadian Geotechnical Journal*, 29(4): 539–550.
- Sheng, D., Kelly, R., Pineda, J. & Bates, L. 2014. Numerical study of rate effects in cone penetration test. In *Proceedings of 3rd International Symposium on Cone Penetration Testing*. Las Vegas, Nevada, USA.
- Suzuki, Y. 2015. *Investigation and interpretation of cone penetration rate effects*. PhD Thesis. Perth, Australia: University of Western Australia.
- Tsubakihara, Y. & Kishida H. 1993. Frictional behaviour between normally consolidated clay and steel by two direct shear type apparatuses. *Soils and Foundations*, 33(2): 1–13.
- Van den Berg, P. 1994. *Analysis of soil penetration*. PhD Thesis. Delft, Netherlands: Delft University of Technology.
- Vardanega, P.J. & Bolton, M.D. 2013. Stiffness of clays and silts: Normalizing shear modulus and shear strain. *Journal of Geotechnical and Geoenvironmental Engineering*, 139(9): 1575–1589.
- Wroth, C.P. 1984. Interpretation of in situ soil tests. *Géotechnique*, 34(4): 449–489.