

DESIGN AND MATERIAL SELECTION FOR A PATIENT TRANSPORT DEVICE IN FIELD HOSPITALS

MAGDA DZIADUSZEWSKA^{1*}, MARTYNA ZIMNA², BEATA ŚWIECZKO-ŻUREK³

^{1,3} Biomaterials Group, Department of Materials Engineering and Bonding, Gdansk University of Technology, Gdansk, Poland.

² Impact zakład projektowo-produkcyjny, Gdansk, Poland.

* Corresponding author: Magda Dziaduszevska, G. Narutowicza 11/12, 80-233, Gdańsk, Poland, e-mail: magda.dziaduszevska@pg.edu.pl.

ABSTRACT

BACKGROUND: A major cause of patient and hospital worker injuries occurs transferring patients between two planes. The main aim of this paper is to propose a design of patient's lift and transfer apparatus for use in field hospitals. The assumption was to design lightweight, durable and ergonomic device using innovative material. The authors concentrated on partial elimination of manual lifting in order to device could work both in two situations: with or without electricity. The paper includes mechanical design, material selection and analytical calculation.

METHODS: In order to carry out strength calculations, the shape and size of device was designed using AutoCAD. Based on a comparison of composite material properties, an epoxy-carbon laminate was selected. The strength calculations were performed in the following order: determination of elementary stresses, determination of the most dangerous cross-section, calculation of tensile strength, calculation of Young's modulus, selection of channel dimensions, determination of material parameters (thickness, fibre mass), determination of substitute stresses.

RESULTS: To design a lightweight, durable and ergonomic patient lift with lifting capacity of 150 kg an epoxy-carbon laminate composed of three layers was chosen. A profile in a C - shape and dimension of 138x90x14 mm has been designed. Patient lift includes an arm of 1,6m height and 1m length of the horizontal beam. The designed transport mechanism uses rollers, a linear electric actuator and a crank with a worm gear.

CONCLUSION: The designed device fulfil the most important criterion, which is to ensure the safety of patients and medical personnel. The height adjustment mechanism partially

eliminates the manual transfer of patients and is adapted to the conditions existing in a field hospital.

Key words: medical apparatus, field hospital, biomaterials, laminates

INTRODUCTION

In a hospital setting, patient transfer is commonly performed by a number of hospital workers. Usually, they must physically lift the patient and move them between two planes – from bed to bed, bed to wheelchair, bed to stretcher etc. Improper lift procedure can lead to serious complication to both - patient and medical staff [1]. Accordingly to the field (mobile) hospital, which can be understood as a temporary hospital applied in case of disasters, accidents or during military situations, transfer devices are also required [2]. Apparatus supporting medical workers should be able to improve their work in hard and unpredictable environments, as well as ensure proper patient's condition.

There are many transfer assist devices available on the market, including transfer boards, slide sheets, roller sheets, transfer belts, and roller boards [3]. There are also complex solutions like mechanical platforms using electrical motors instead of physical strength [4]. While using the first group of devices can lead to many health complications, the reality of costs enforces resignation from more advanced solutions.

In this section we provide a review of existing solutions for eliminating manual lifting and enabling transportation, that consists of two movements: lifting and moving. Mobile lifts and overhead lifts are distinguished [4]. Mobile lifts have a wide range of functions. The patient can be moved from place to place, as well as raised and lowered to a specific height. Various transporting mechanisms exist: manual, hydraulic or pneumatic. The lift is a stable construction, that moves on skids. Other elements of its construction include: a vertical column, carrying arm, handle and various types of transport belts. Due to its strength, safety and comfort of the users are ensured. Its advantages include also low weight, easy disassembly and a wide variability [5]. Second type of transporting devices, overhead lifts, belong to devices, that allow transport of patients using an installed rail system. The patient has access to the places along which the rails run, e.g. transport to a second bed, to the bathroom or another room. They can be mounted both to the ceiling, walls and special wall supports. Their maximum span is 8 m. Ceiling lifts are a great solution in narrow aisles and tight spaces. The capacity of this type of devices is approximately 200 kg. Compared to the mobile lifts, purchase and installation of a ceiling lift is much more expensive [4].



Devices available on the market perform their functions in a hospital setting. However, none of the discussed types use a transport mechanism, that allows the device to work under accessibility conditions and the lack of electricity. In addition, device prices often outweigh the financial capabilities of hospitals.

The main aim of this paper is to propose a design of patient's lift and transfer apparatus for use in field hospitals. The assumption was to design lightweight, durable and ergonomic device using innovative material. The authors concentrated on partial elimination of manual lifting in order to device could work both in two situations: with or without electricity. This paper describes the specification, mechanical design, material selection and analytical calculation.

MATERIAL AND METHODS

The requirements towards the solution related to functionality, construction and material selection were determined by the conditions and particular place of its intended work environment, which is mobile hospital.

1. Functional requirements

The basic function that should be fulfilled by the device is patient's transport, including lifting and transfer movement both between the planes and between the rooms. In order to relieve medical workers, the solution should be mechanized. However, the field conditions in which the device will operate could also force manual lifting during a power shortage.

2. Construction requirements

First of all, the construction assumptions include: strength (lifting capacity of 200 kg), lightness, ergonomics. Second, the size of the device should be adapted to the hospital conditions (size of rooms, beds). Third, simplicity for minimizing failure rate. The construction should be durable and reliable.

3. Material requirements

The main criteria include the strength of the material, its resistance to cracking, Young's modulus and fatigue index. The economic conditions are also important – the availability and low costs of materials in relation to their quality and consumption rate. In view of its working area the material has to be corrosion-resistant. Production properties are also very important, such as: ease of making, joining individual elements and their finishes. When choosing the right material, the designer should also consider aesthetics, i.e. gloss, roughness, etc.

Material selection

Analysis of material properties allowed to specify two groups of materials – steel and laminates, that best meet the assumed criteria. Due to lower density and better corrosion

resistance, a material from the group of laminates was chosen [6]. Based on a comparison of composite material properties, an epoxy-carbon laminate was selected. High stiffness and low weight have outweighed the lower durability for dynamic loads that are not present in the design. The proposed laminate structure is made of three layers arranged alternately. A literature review allowed to construct the following assumptions: BXC type outer layers should have an equal thickness and the ratio of the thickness of the inner layer to the outside should be approximately 2:1. The outer layers are multidirectional fabric in the Biaxial (BXC) version, in which the carbon fibres are laid at an angle of $\pm 45^\circ$. The inner layer is an Unidirectional Composite (UDC) roving fabric with one-way fibres [7].

Transport mechanism

According to the requirements, project of the transporting mechanism involves two movements: height adjustment and patient movement. During designing the height adjustment mechanism (lifting / lowering), five variants of solutions were analyzed. Each concept assumes a set of rollers and band transferring the main tensile forces, the differences between the concepts are various version of the mechanisms providing up-down movement. In the initial phase of the project, the use of a pneumatic cylinder, hydraulic cylinder and trapezoidal jack was considered, however, these variants were rejected due to the inability to operate the device during lack of electricity. The concepts including combination of automatic and emergency mechanisms are presented in Table 1.

Table 1 Concepts of the lifting mechanism, schemes and disadvantages of the solutions

Concept I includes an electric motor with a gear, connected by means of a clutch with a shaft terminated with a lever. Concept II contains an electric motor, a screw rotor with a trapezoidal thread and a cogwheel. The emergency system includes a gas spring placed under the engine, crank, shaft and worm drive. Concept III includes a shaft, a worm wheel and a motor connected with a worm joined to the crank, as well as a lever for switching these two systems. Concept IV is a simplification of the previous concept, it includes a starter motor with two projections, a crank, a worm gear and a shaft. The last concept (concept V), presents a modification of all the mechanisms described that the main disadvantages occurring in each variants are excluded. The designed mechanism uses rollers on which the rope moves, a linear electric actuator: WhisperTrack model [8] and a crank with a worm gear. The electric actuator located at the base of the device has a specially designed tip through which the rope passes,

which, in turn, goes to a slightly higher mounted shaft ending with a gear-operated crank. Lifting and lowering the patient is based on the movement of the actuator, which either increases or decreases the tension of the rope. The manual operation of the device is turning the crank and winding / unwinding the rope on / from the shaft. This movement is possible due to the worm gear. In order to ensure proper stability of the actuator, a piston stabilizing fin was designed. The fin moves in a rail mounted in the wall of the device. Transferring the patient between two planes involves lift slings hooking up to the mechanical arm. The second type of required movement – transporting between rooms, is ensured by four steering wheels mounted on skids. The two rear ones have a foot brake to immobilize the device in a given location and to ensure stability and safety. The wheels were selected from the Emile Maurin Elements Standard Mecaniques Cataloges [9]. Their basic dimensions are: diameter = 125 mm, width = 37.5 mm, height of the whole wheel set = 150 mm. The selected mechanism variant is shown in Fig.1.

Fig. 1 Patient's transport device and transporting mechanism (final concept-V)

The shape and profile of the device

Lamination technology is one of the criteria that determine the shape of the profile. The profile will be made using a contact method for applying laminate layers to a specially prepared internal form. To remove the form after the lamination operation, it should take the shape of the channel. Due to the fact that the shape of the form imposes the shape of the profile, a profile in the shape of a channel bar was chosen for the designed device. At the base, the profile will be reinforced with a steel beam that loads the arm. In addition, the steel profile will facilitate the installation of skids with wheels and the actuator inside the device. A cross-section of the patient transport device with visible lifting / lowering mechanism is shown in Fig. 1.

RESULTS

The strength calculations were carried out in the following order: determination of elementary stresses, determination of the most dangerous cross-section, calculation of tensile strength, calculation of Young's modulus, selection of channel dimensions, determination of material parameters (thickness, fibre mass), determination of substitute stresses. The



calculations, regarding the properties of laminates have been made in accordance with the European standard EN ISO 12215-5: 2008 [10].

The vertical bar is simultaneously bent and compressed, while the horizontal bar is bent and sheared. Fig. 2 shows the distribution of bending moment and shear force from force N in the xy plane.

Fig. 2 Distribution of bending moment and shear force depending on force N in the xy plane

The following drawings show the cross-section of the vertical (Fig. 3 a) and horizontal beam (Fig. 3 b) in the most dangerous place with the forces applied and the stress distribution.

Fig. 3 The cross-section of the vertical beam (a) and horizontal (b) in the most dangerous place with the forces applied and the stress distribution.

Due to the fact, that the parameters of the laminate depend on the parameters of the given layer, different values are assumed for the BIAXIAL type fabrics, and different for the UDC type fabrics. The calculations of the tensile strength and the Young's modulus are presented in accordance to EN ISO 12215-5: 2008 with Nominal mass content of fibres (Table 2).

Table 2 Tensile strength and Young's modulus

Subsequently, the allowable stresses k are calculated, assuming the safety factor $x = 3$.

$$k = \frac{R_m}{x} = 163,842 \text{ MPA}$$

The next step of the project was selection of the device's profile dimensions. An electric linear actuator with base: 88x50 mm determinate the minimum dimensions of a channel bar. A channel angle of 138x90x14 mm has been chosen. Table 3 presents the results of strength calculations for the selected profile: substitute stress in the vertical and horizontal beams, and the deflection in the x and y axis.

Table 3 Strength calculation for 138x90x14 mm profile

According to a Table 3 the profile fulfils the strength conditions ($\sigma_z \leq k$) and the deflection (f) is acceptable.

Selection of the C-profile dimensions allowed to determine the thickness and the fibre mass for the individual layers of laminates. Due to the literature sources the following assumption was used in the calculations: BXC type outer layers should have an equal thickness, the ratio of the thickness of the inner to the outside layer should be approximately [7]. Starting from the above assumptions and knowing the thickness of the whole profile, the thickness of individual layers were assumed. According to the EN ISO 12215-5: 2008 standard, the mass of fibres of UDC and BXC layers were calculated using the following mathematical formula:

$$\frac{t}{w} = \frac{1}{2,16} \times \left(\frac{1,8}{\Pi} - 0,6 \right)$$

To summarize the information about the laminate (Table 4), a laminate composed of three layers has been chosen for the designed device: external layers BXC, each with a thickness of 3.71 mm containing 0.0033 kg of fibres per square meter, and an internal layer of UDC with a thickness of 6.57 mm and a fibre mass equal to $0.0056 \left[\frac{kg}{m^2} \right]$.

Table 4 The mass of carbon fibres of individual layers depending on the mass content of fibres in the laminate and the thickness of the given layer

DISCUSSION AND CONCLUSION

The designed device fulfils the most important criterion which is to ensure the safety of patients and medical personnel. The height adjustment mechanism partially eliminates the manual transfer of patients. The device has been adapted to the conditions existing in a field hospital. Due to two usage options of the solution (manual and electrical), the device is useful both when electricity works as well as during its shortage. In addition, according to previous assumptions, the lift is made of a material that provides strength (lifting capacity of 150 kg) and makes the device aesthetic. The solution using the laminate allowed to obtain an innovative one-element C-shaped profile. In addition, the use of a simple lifting mechanism significantly reduces the cost of the designed device. This may be an important argument for potential customers looking for a reliable and affordable solution of patient transfer. In order to improve the designed device, one may consider reducing the size of the profile. For this purpose, different combinations of the amount and type of laminate layers should be analyzed to achieve even better strength properties with reduced thickness.

NOTES

Conflicts of interest

The authors certify that there is no conflict of interest with any financial organization regarding the material discussed in the manuscript.

Authors' contributions

M.D. and M.Z. conceived and planned the experiments. M.D. and M.Z. carried out the experiments and contributed to the interpretation of the results. All authors provided critical feedback and contributed to the final manuscript.

Acknowledgements

This study was performed due to collaboration with Obstetrics Clinic Hospital of the Medical University of Gdańsk. We thank Prof dr hab. inż. Jerzy A. Ejsmont for assistance with part connected with transport mechanism and for comments that greatly improved the manuscript. We would also like to show our gratitude to GALEON company for sharing their knowledge about laminates.

REFERENCES

- [1] Collins J, Nelson A, Sublet V. Safe Lifting And Movement Of Nursing Home Residents. Dhhs (Niosh) 2006; 2006-117.
- [2] "Field Hospital" [Internet]. Collins English Dictionary - Complete & Unabridged 10th Edition; 2018 [cited 2018 Feb 10]. Available from: <http://www.Dictionary.Com/Browse/Field-Hospital>.
- [3] Labdali H, Hassane A. Patient Transfer System. Lawrence Technological University, Michigan, 2012.
- [4] Mary M. VHA Patient Care Ergonomics, Patient Handling Equipment Coverage & Space Recommendations, 2016.
- [5] Simon WH. Storable Patient Lift And Transfer Apparatus. Us Grant Us5560054a [Internet] 1994 [cited 2017 Jan 12] Access: <https://patents.google.com/patent/us5560054a/en>.
- [6] Chou TW, Bunsell AR. Laminates. Elastic Properties. The Concise Encyclopedia of Composite Materials 1996; 159–173.
- [7] Królikowski W, Kłosowska-Wońkiewicz Z, Penczek P. Żywice i laminaty poliestrowe. Wydawnictwa Naukowo-Techniczne, wydanie II zmienione i uaktualnione, Warszawa, 1986.



- [8] Thomson Catalogue. Linear Electric Actuators [Internet] 2018 [cited 2017 Jan 14]. Available from: https://www.thomsonlinear.com/downloads/actuators/whispertrak_electric_linear_actuators_bren.pdf.
- [9] Emile Maurin Elements Standard Mecaniques Cataloges. Wheels [Internet]. 2018 [cited 2017 Jan 14]. Available from: <http://pdf.directindustry.fr/pdf/tab/wheels.html>.
- [10] PN-EN ISO 12215-5:2009 - Wersja Polska, zastępuje PN-EN ISO 12215-5:2008 - wersja angielska. Małe statki - konstrukcja i wymiarowanie kadłuba - Część 5: Obciążenia projektowe dla jednokadłubowców, naprężenia projektowe, wymiarowanie elementów konstrukcyjnych, 2009.

TABLES

Table 1 Concepts of the lifting mechanism, schemes and disadvantages of the solutions

Concept	Scheme	Disadvantages
I		Lack of self-braking in the emergency mechanism
II		Lack of self-restraint in manual mechanisms, necessity of frequent lubrication, noise
III		Noise, Complicated solution
IV		Necessary effort to start the engine, the handle cannot be removed

Table 2 Tensile strength and Young's modulus

LAYERS	TENSIL STRENGTH	YOUNG' S MODULUS
	$R_m = 990\eta_{\text{carbon}} - 90$ $\eta_{\text{carbon}} = 0,99\eta_{\text{glass}}$ $R_m = \frac{R_{m\text{UDC}} + R_{m\text{BIAXIAL}} + R_{m\text{UDC}}}{3}$	$E = 100000\eta_{\text{carbon}} - 9000$ $E = \frac{E_{\text{UDC}} + E_{\text{BIAXIAL}} + E_{\text{UDC}}}{3}$
UDC $\eta_{\text{glass}} = 0,58$	$R_m = 478.458 \frac{\text{N}}{\text{mm}^2}$	$E = 48420 \frac{\text{N}}{\text{mm}^2}$
BIAXIAL $\eta_{\text{glass}} = 0,60$	$R_m = 498,06 \frac{\text{N}}{\text{mm}^2}$	$E = 50400 \frac{\text{N}}{\text{mm}^2}$
SUM	$R_m = 491,526 \frac{\text{N}}{\text{mm}^2}$	$E = 49740 \frac{\text{N}}{\text{mm}^2}$

Table 3 Strength calculation for 138x90x14 mm profile

Profile	$\sigma_g = \frac{M_g}{W_x}$ [Pa]	$W_x = \frac{I_x}{e_{max}}$ [m ³]	I_x [m ⁴]	e_{max} [m]	$\sigma_s / \tau_t = \frac{N}{A} / \frac{T}{A}$ [Pa]	A [m ²]	σ_z [Pa]	f [m]
Vertica 1	793447 9	0,0001 89	0,0000 16548	0,061 65	359539,7 891	0,0041 72	79588 79	0,0075 04
Horizo ntal	793447 9	0,0001 89	0,0000 049861	0,002 46	910746,8 124	0,0016 47	17424 31	0,0033 12

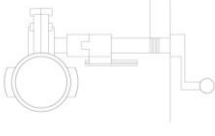
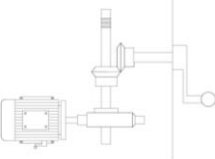
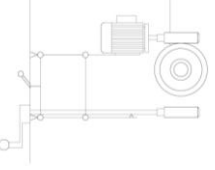
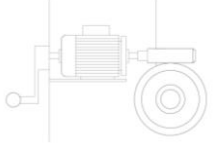
Table 4 The mass of carbon fibres of individual layers depending on the mass content of fibres in the laminate and the thickness of the given layer

Layers	The mass of carbon fibres $w \left[\frac{\text{kg}}{\text{m}^2} \right]$	Mass content of fibres in the laminate η	Thickness t [mm]
BXC	0,0033	0,594	3,712963
UDC	0,0056	0,5742	6,571694
BXC	0,0033	0,594	3,712963
Sum	0,0122	0,584911	13,99762

FIGURES

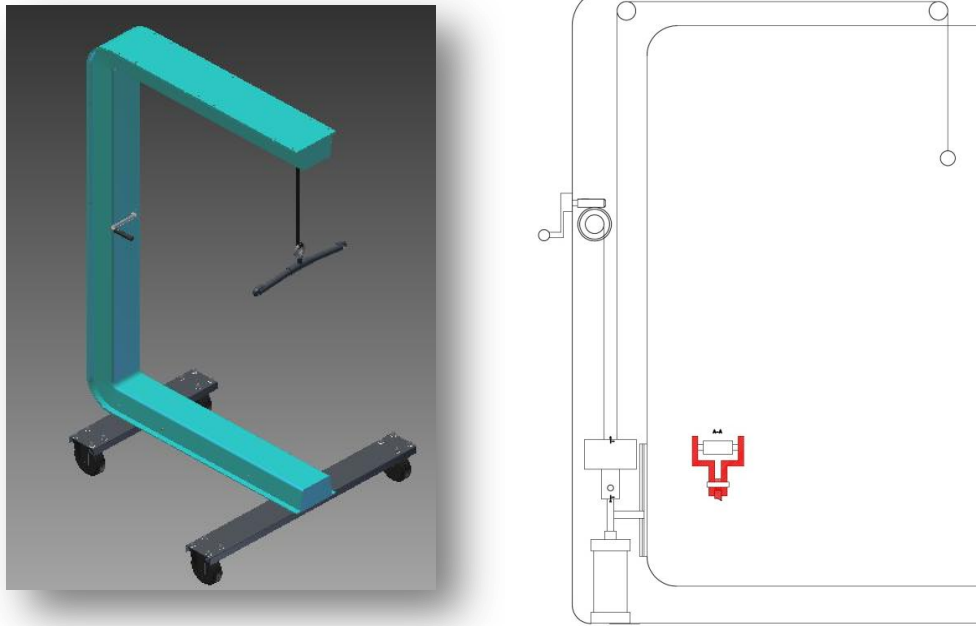

Fig. 4 Patient's transport device and transporting mechanism (final concept-V)

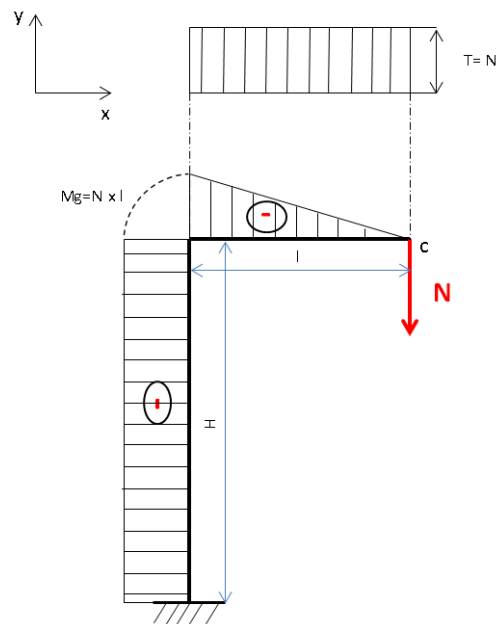

Fig. 5 Distribution of bending moment and shear force depending on force N in the xy plane

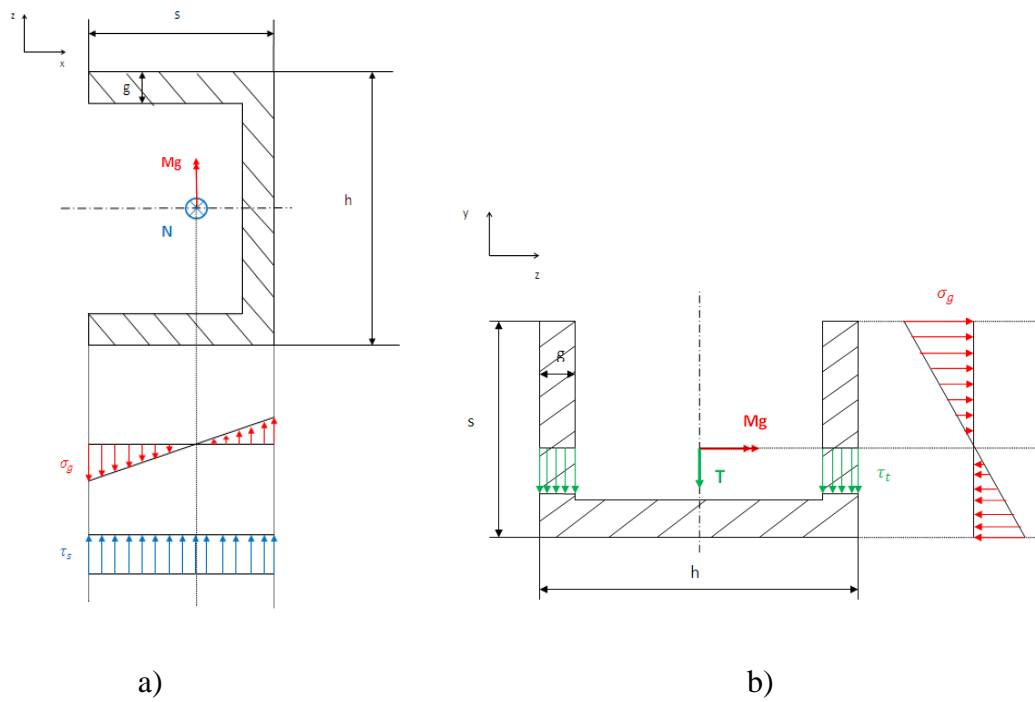

Fig. 6 The cross-section of the vertical beam (a) and horizontal (b) in the most dangerous place with the forces applied and the stress distribution.