

Control of a vapour microturbine set in cogeneration applications

Wojciech Włodarski

Gdansk University of Technology, Faculty of Mechanical Engineering, Department of Energy and Industrial Apparatus, Narutowicza 11/12, 80-233 Gdansk, Poland

Abstract

Systems with microturbines are implemented for local generation of heat and electricity. This paper presents the analysis of control concepts for a vapour microturbine set with a generator with permanent magnets, intended to work in small heat and power plants. Control system variants differed by the selection of controlled signals and set parameters. Possible ways of control were discussed and compared with experimentally determined static characteristics of the microturbine set. The simulation calculations were performed to check the control systems operation in various expected operating conditions.

Keywords: energy systems, cogeneration, microturbines, control systems, simulations

1. Introduction

Distributed energy systems are decentralized, modular and flexible technology, which can comprise multiple generation and storage components [1]. In a dispersed power industry, low power devices are used for local generation of heat and electricity. Micro-cogeneration systems are appropriate for institutional or office buildings, hospitals, hotels and family residential buildings [2]. They can be one of the components of mini/micro-grids, which are electrical systems that serve diverse users and can be interconnected and interact with the main utility grid or operate independently [3, 4].

The development of micro-cogeneration systems takes place in different areas. On the one hand, it is necessary to apply compact heat exchangers [5–

Email address: wwlodar@pg.edu.pl (Wojciech Włodarski)

7], on the other hand, micro-engines. Volumetric [8–10] and turbine [11–13] engines are developed in parallel. Gas microturbines are applied [14–17] as well as steam or vapour microturbines [18–22]. The Organic Rankine Cycle is executed [23] with low-temperature heat sources (for example, geothermal [24], ocean [25], solar [26, 27] or waste heat recovery systems [28, 29]). ORC technology is considered as a prospective for cogeneration systems with a household scale [30–32].

A microturbine set is designed for operation in particular conditions, i.e. at given parameters of a working medium, and a given electric load. However, during operation lifetime a microturbine set can operate in conditions differing from calculation parameters. In such a case, a turbine set will operate at a partial load or an overload, the rotational speed can also change. Not all of the above changes are permissible, due to strength reasons, the durability of a generator winding and required values of voltage and current. An adequate state of a microturbine set operation should be maintained as a result of an action of an automatic control system. Two basic categories of turbine control can be recognized: safety (protection) systems and process systems [33]. The safety systems are intended to eliminate the possibility of device damage. The process systems control the operation, so as to follow the process conditions in a stable and efficient manner.

The control problems of the turbine sets can be found in the literature, but most of them deal with large steam turbines [34–38], gas turbines [39, 40] or gas microturbines [41, 42], which makes it difficult to draw conclusions on low power vapour devices. Publications focusing on a control of vapour microturbine sets for use in cogeneration micro power plants are very rare [43] and do not use experimental and simulation results. In addition, these works usually transfer the methods used in a "macro" scale to "micro" devices, without introducing innovative solutions resulting from the specific features of such devices.

When considering the concept of an automatic control system, it would be necessary to have characteristics that take into account a possibly wide range of operating conditions of the microturbine set. If the considered device is a prototype, then the characteristics should be obtained as a result of an experiment. Published results of the experimental examination referred to vapour microturbines in changing operating conditions are rare [44–47].

This paper presents the analysis of selected variants of the automatic control system for the vapour microturbine set with the generator with permanent magnets, intended to work in small heat and power plants. Experi-



mental static characteristics of the microturbine set were prepared to present the sample areas of control system operation. In some variants, the control system performed its tasks by throttling the working medium in the control valve situated at the turbine inlet. This method of microturbine sets control is similar to that used for controlling high power turbine sets [48–53]. We should bear in mind, however, that in microturbine sets, the basic task of which is heat delivery, reducing a mass flow rate of working medium in a turbine it does not have to be equivalent with fuel consumption decrease. In this case, a flow rate of a working medium only depends on a demand for thermal energy, and after reducing a flow through the turbine, its missing amount is to be delivered through a reduction and cooling station, leaving aside a turbine. That is why the alternative control method is proposed for vapour microturbine sets, which consists in utilizing or dissipating surplus electrical energy in a resistor. In this solution, an entire rate of working medium flows through a turbine, and a reduction and cooling station is not used. This is the innovative method not previously described in the literature.

The results of simulation tests of selected variants of the automatic control systems for the vapour microturbine set were also presented and discussed. The purpose of the simulations was to check whether in the transient conditions the proposed control systems can properly carry out their tasks.

2. Concepts of micro-cogeneration units control

There are three main principles of cogeneration systems operation: topping cycle, bottoming cycle and combined cycle [54]. In the case of the topping cycle fuel is first used to generate the electricity, and a portion of the waste heat from power generation is used to deliver useful thermal energy. Bottoming cycle systems first produce useful heat, and recover some portion of the exhaust heat to generate electricity. The topping and bottoming cycle can be joined together to form a combined cycle.

The object of consideration is the micro-cogeneration unit operating with the combined cycle principle. The general idea of such a system is schematically presented in Figure 1. The main components of this station are: a boiler fit to combust different kinds of fuels, a high temperature thermal loop delivering heat and a low-temperature thermal loop delivering heat and electric energy. The sample schematic diagram of a low temperature thermal loop is shown in Figure 2. The main components of this unit are: an evaporator, a microturbine with a low boiling working medium, a generator, a condenser



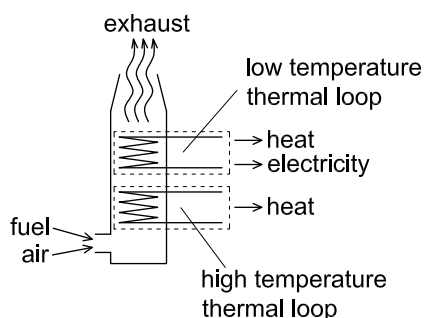

Figure 1: The scheme of a cogeneration unit

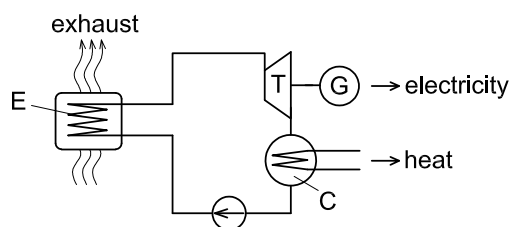

Figure 2: A low-temperature thermal loop with an ORC unit, E- evaporator, T- turbine, G- generator, C- condenser

and a circulating pump. In a presented heat cycle, electric energy is a by-product and forms only about 10-20% of total heat [55]. A cogeneration unit, first of all, is intended for heat delivering and a microturbine set can deliver as much electric power as it results from an amount of delivered heat [43]. A microturbine set is connected, via a rectifier or a rectifier/inverter system, with a power receiving system, which can be an individual receiver or an external electric power system. Permanent magnets can be used to replace an excitation winding of a synchronous generator.

If an internal electric power system of a supplied object is connected with an external system electric energy can flow in either direction. If an amount of electric energy produced by a power plant (depended on a delivered heat) exceeds a demand of an internal electric power system, surplus energy is transmitted to an external system. On the other hand, when a microturbine set produces an insufficient amount of electric energy, its shortage is compensated from an external system.

When an internal electric power system is not connected with an external system, a situation may occur in which an amount of electrical energy



produced by a microturbine set exceeds a total demand of all receivers in a considered object. In this situation three types of an action can be considered:

- storing surplus electric energy produced by a microturbine set,
- reducing the electric power of a microturbine set by the decreasing a rate of a working medium flowing through a turbine,
- utilizing or dissipating surplus electric energy produced by a microturbine set.

Due to a limited capacity of potential energy accumulators an effective storage of electric energy, in operating time intervals during which a microturbine set produces more electrical energy than needed, would be limited. Moreover, it should be considered whether electric energy receivers within a dedicated electric power system will be able to consume earlier stored energy. Otherwise, a situation may occur in which full charging of accumulators makes the further storage of surplus energy impossible.

The basic task of a considered heat and power plant is heat delivery, therefore reducing a mass flow rate through a turbine must not change medium parameters in a heat network. This can be prevented by equipping a micro heat and power plant installation with a reduction and cooling station [43]. The sample schematic diagram of this solution is shown in Figure 3. When a production of electric energy exceeds a demand and a mass flow rate through a turbine is reducing, part of a working medium is directed to heat receivers via a pipe bypassing a microturbine, after throttling and cooling in a reduction and cooling station, in such a way as to maintain the constant rate of delivered heat. Vapour pressure and temperature should be reduced to values in a condenser. A correct division of flows of a working medium is ensured by two control valves situated in front of a turbine and in front of a reduction and cooling station. If a heat flow rate to receivers does not fully cover a heat demand, a missing amount of heat can be delivered by increasing a flow through a reduction and cooling station.

As an alternative, for the above-described method of a heat and power delivery control with the aid of a reduction and cooling station, the method which consists in utilizing or dissipating surplus electrical energy produced by a microturbine set is proposed. The schematic diagram explaining the principle of this method is shown in Figure 4. In this variant, in nominal

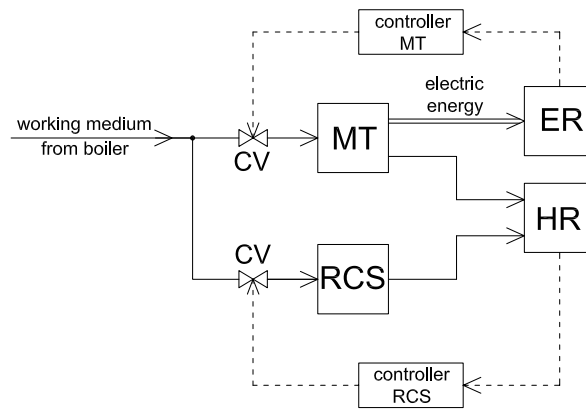

Figure 3: The schematic diagram of a heat and electric energy delivery control in a heat and power plant with a vapour microturbine set: MT - microturbine set, HR - receivers, ER - electric power receivers, RCS - reduction and cooling station, CV - control valve, controller MT - microturbine set controller, controller RCS - reduction and cooling station controller

operating conditions an entire mass of a working medium flows to heat receivers through a microturbine. If an amount of produced electrical energy exceeds a demand, its surplus is directed to an additional electric power receiver in which this energy is converted to heat and utilized (for example in a boiler circuit) or dissipated in the environment. A utilization of surplus energy can be achieved, for example, by introducing an electric heater into a boiler supply system. The solution with a dissipation of excess energy is disadvantageous due to an overall efficiency of a power plant, but it can be competitive due to a simplification and thus a reduction of investment costs. This additional receiver can have an option of power control (for instance, by changing electrical resistance in the case of resistance type load). The above solution, in combination with an appropriate control system, would make surplus electrical energy consumed, at the same keeping constant assumed operating parameters of a microturbine set. This variant can also include a reduction and cooling station, which is switched on during the microturbine set shutdowns (due to failure, for instance). A correct flow rate of a working medium (with respect to heat demand) is ensured by an only one control valve, which performs its task regardless whether a flow is directed to heat receivers through a turbine or through a reduction and cooling station. If a construction of a condenser allows for an introduction of a vapour of high parameters (when a microturbine set is turned off), it would be possible to

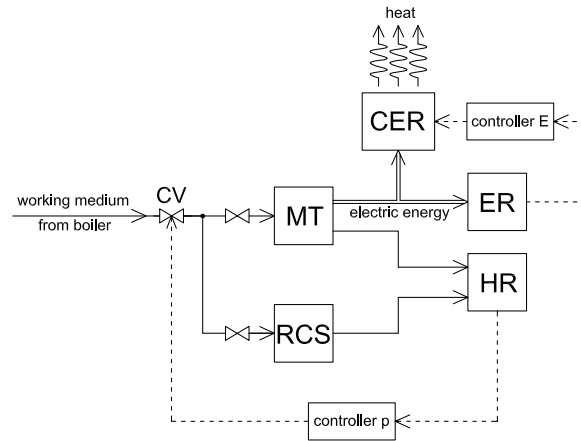

Figure 4: The schematic diagram of a heat and electrical energy delivery control in a heat and power plant with a vapour microturbine set, with the variant with surplus electrical energy dissipation: MT - microturbine set, HR - heat receivers, ER - electric power receivers, CER - controlled electric power receiver, RCS - reduction and cooling station, CV - control valve, controller p - valve controller, controller E - electric power receiver controller

dispense with a reduction and cooling station.

It can be expected that in the case of a small power system (for example, an individual household), an electricity demand may dynamically change. Switching on a single device or several devices at the same time can produce a peak demand of several kilowatts [56], which is a challenge for a microturbine control system. Thermal and flow phenomena are characterized by relatively high inertia. It can, therefore, be concluded that the control strategy consisting in a dividing a vapour flow between a turbine and a reduction and cooling station may not provide adequate control quality during step changes in a generator load. In addition, large and rapid changes of a turbine power can be disadvantageous due to strength reasons. Against this background, the proposed alternative control method appears to be competitive. Due to an inertia of a vapour flow and an inertia of a microturbine set rotor, a control from an electrical side can be more effective. In this system, a turbine operates at a constant load, which is advantageous for reasons of a durability. Replacing a control valve and a mechanical actuator with an electrical system can be competitive due to a reliability and investment costs.

3. Concepts of vapour microturbine sets control systems

If an amount of produced electrical energy is greater than an individual receiver's demand, or this energy cannot be received by an external electric power system, a turbine torque will become larger than that of a generator and a rotational speed of a microturbine set can increase. In turbine sets that directly supply an AC power system, the task of a control system is to maintain a set rotational speed proportional to a frequency in a power net. Microturbine sets, due to high rotational speeds, usually supply a network through a rectifier and an inverter, which shapes an electric current with a given frequency. Therefore, maintaining a constant rotational speed does not have to be necessary. An increase of a rotational speed, however, increases stress from the centrifugal forces in the rotating elements of a turbine and a generator so the task of a microturbine set control system should be to prevent a set against exceeding a rotational speed limit.

It should also be taken into consideration that electric power receivers need, as a rule, electric energy with a correct voltage to work properly. This may particularly apply to an application in which a microturbine set powers a DC microgrid [57]. An output voltage at generator terminals can change after changing the operating conditions (load and rotational speed). Therefore, the other task to be performed by a microturbine set control system should be to maintain a set output voltage.

Three basic concepts, differing by the selection of the controlled signals, are proposed for an automatic microturbine set control system. In these concepts:

- a rotational speed of a microturbine rotor and an output voltage are simultaneously controlled,
- the only controlled signal is a rotational speed,
- the only controlled signal is an output voltage.

The variant in which a rotational speed and a voltage are simultaneously controlled is profitable with respect to a strength of rotating microturbine set elements (turbine rotor, generator rotor and bearings). Simultaneously, it ensures an adequate voltage for a correct operation of electric power receivers.

The sole control of a rotational speed ensures meeting strength requirements concerning a turbine and a generator. A structure of a control system

is simpler than that in the previous variant. A voltage is a resulting parameter, and its value will change to respond to microturbine generator load changes, which may cause problems with a correct operation of electric power receivers.

The concept in which a voltage is solely controlled provides correct operating conditions for electric power receivers, at the same time retaining the structural simplicity of a control system. In this variant the rotational speed, being an uncontrolled parameter, will change after each change of a microturbine generator load. This may lead to a stress increases in the rotating turbine and generator elements. However, we should keep in mind that, unlike high power turbines, most variants of microturbines are not heavily strained structures in terms of strength parameters. For instance, the calculated tensile stress generated by centrifugal forces in the hub section of the microturbine rotor blade (described in [44, 58, 59]) at the rotational speed of 8000 rpm (the nominal rotational speed at which the turbine reaches the maximum efficiency) was equal to 1 MPa. When the rotational speed increases, this stress increases parabolically. It means, that after increasing the rotational speed to 16000 rpm, (the theoretical maximal rotational speed of this turbine) the stress would increase to 4 MPa. This is a very small value, compared to the yield point of the material used for manufacturing the microturbine blades (aluminium alloy PA6) which is equal to 240 MPa. Therefore, we can expect that each time the microturbine set structure is selected in such a way that the strength requirements concerning rotating elements of the turbine will be met within the entire range of its real rotational speed.

4. Automatic control systems for a vapour microturbine set with a generator with permanent magnets

The object of the analysis is a control system for a microturbine set the schematic diagram of which is shown in Figure 5. A microturbine set consists of a microturbine (1) and an electric current generator (2), connected with each other. A three-phase generator with permanent magnets is used. A generator is connected via phase conductors with a rectifying system (a diode rectifier), which converts an alternating current from three generator phases to a direct current. A microturbine generator load is represented by a resistor with resistance R (or a set of resistors with a resultant resistance R).



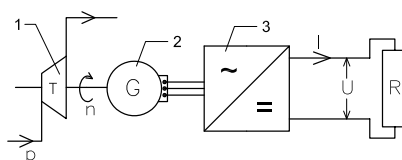

Figure 5: The simplified scheme of a microturbine set: 1-microturbine, 2-generator, 3-rectifying system, R-load resistance, p-working medium pressure at a turbine inlet, n-rotational speed, U-voltage, I-electric current

Five possible variants of an automatic microturbine set control system, differing by a selection of controlled signals and a way of execution a formulated task, were analysed. In some variants, a control system performed its tasks by throttling a working medium in a control valve situated at a microturbine inlet. This is a method indicated in the literature dealing with an automatic control of vapour microturbines [43, 60, 61]. The alternative control method is also proposed for microturbine sets, which consists in consuming surplus electrical energy in a resistor with controlled resistance. In this solution an entire rate of working medium flows through a turbine, and a reduction and cooling station is not used. Since a generator type most commonly found in microturbines is a permanent magnet generator, no regulation was considered by changing the excitation current.

Static characteristics of the microturbine set are included to present the areas of a control system operation. The mentioned characteristics were obtained as a result of the five-stage microturbine set experimental tests. A detailed documentation of the microturbine set and the laboratory test rig can be found in: [44], [46].

4.1. A microturbine rotor speed control by changing pressure at a turbine inlet

The exemplary area of operation of the microturbine set working at the constant rotational speed is shown on the experimentally determined static characteristic in Figure 6. When the resistance of electric power receivers increased, the rotational speed was kept constant by decreasing the working medium pressure at the turbine inlet. An increase of the load resistance was accompanied by a simultaneous increase of the microturbine generator output voltage.

Accordingly, a speed of a microturbine set rotor can be kept constant and equal to a set value by controlling a working medium pressure at a turbine

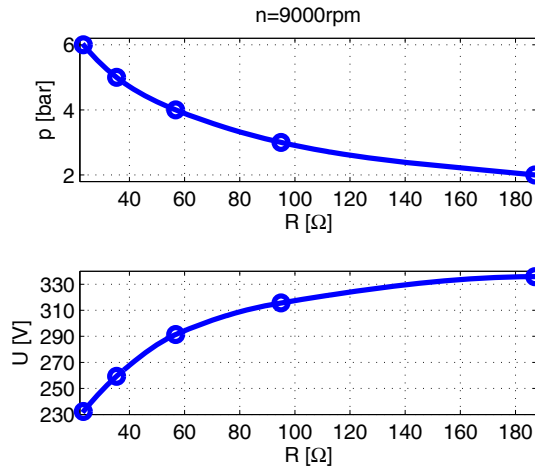

Figure 6: Pressure p at the turbine inlet and voltage U as functions of resistance R of electric power receivers, for rotational speed $n = 9000$ rpm

inlet. The schematic diagram of this type of automatic control is shown in Figure 7. A microturbine set consists of a microturbine (1) which drives a generator (2), which, in turn, delivers electric power, via a rectifying system (3), to an electric power receiver with resistance R . This resistance can change during a microturbine set operation, for instance after connecting or disconnecting electrical devices by an energy receiver. A control valve (5) is installed on a turbine supply pipeline. Turbine inlet pressure can be controlled by changing a valve setting. Based on a instantaneous rotational speed value, a controller (4) controls a valve (5) in such a way as to maintain a set rotational speed value.

The simplified schematic diagram of an automatic microturbine speed control system is shown in Figure 8. A controlled signal is a rotational speed, while an electric current and a voltage are resulting signals. A resistance of electric power receivers is a disturbing parameter. An instantaneous value of a rotor speed is compared with a set value at a summing node. Based on a control error, a rotational speed controller forms a steering signal for a control valve.

4.2. A microturbine rotor speed control using an additional resistor with controlled resistance

The exemplary operation area of the microturbine set working at the constant rotational speed is shown in Figure 9, which presents static charac-

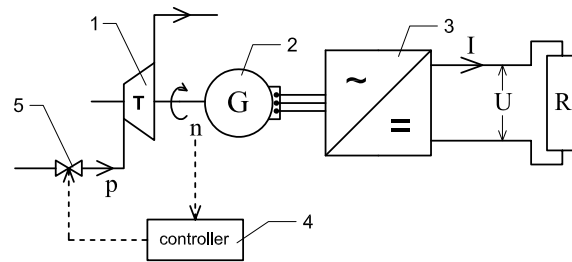

Figure 7: The schematic diagram of an automatic rotational speed control system for a microturbine set; 1-turbine, 2-generator, 3-rectifying system, 4-microturbine set controller, 5-control valve, p-pressure at a turbine inlet, n-rotational speed, U-voltage, I-electric current, R-resistance of an electric power receiver

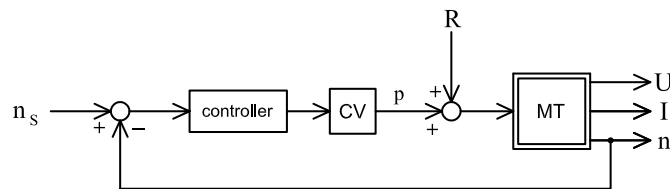

Figure 8: The simplified block diagram of a microturbine set speed control system; MT-microturbine set, CV-turbine control valve, p-pressure at a turbine inlet, R-resistance of an electric power receiver, U-voltage, I-electric current, n-rotational speed, n_s -set speed value

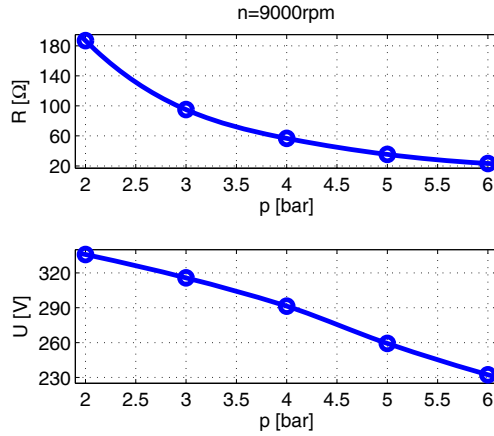

Figure 9: Resultant resistance R of the generator load and voltage U as functions of pressure p at the turbine inlet, for rotational speed $n = 9000$ rpm

teristics experimentally determined for the microturbine set working in that regime. When the pressure at the turbine inlet increased, the rotational speed was kept constant by decreasing the generator load resistance and, consequently, the microturbine generator output voltage.

Accordingly, a microturbine set rotational speed can be kept constant and equal to a set value by forming a resultant generator load. Figure 10 shows the schematic diagram of this type of automatic control for an analysed microturbine set. A microturbine set produces electric energy for a receiver (4) with resistance R_R . This resistance can change during operation, for instance after connecting or disconnecting electrical devices. A resistor (5) with a controlled resistance R_C is installed in parallel with an electric power receiver. A structure of a controlled resistor makes it possible to change its resistance during a microturbine set operation. The task of a controlled resistor is to consume surplus energy produced by a microturbine set. The resultant resistance of a microturbine generator load is R , and its value is a combination of resistances of electric power receivers and a controlled resistor. An inverse of a resistance R is a sum of inverses of resistances R_R and R_C . A signal controlling a resistance R_C is formed by a controller (6), based on an instantaneous rotational speed value, in such a way as to maintain a set speed value regardless of pressure at a turbine inlet and a resistance of electric power receivers.

The simplified block diagram of an automatic microturbine set control

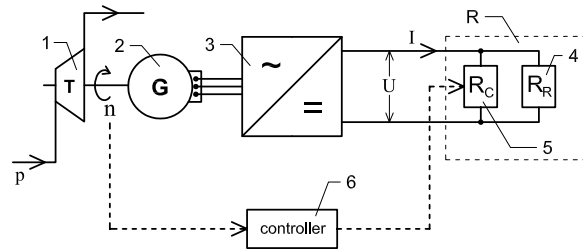

Figure 10: The schematic diagram of a speed control system for a microturbine set: 1- turbine, 2- generator, 3- rectifying unit, 4- electric power receiver with resistance R_R , 5- resistor with controlled resistance R_C , 6- rotational speed controller, n - rotational speed, p - pressure at a turbine inlet, I - electric current, U - voltage, R - resultant resistance of a load

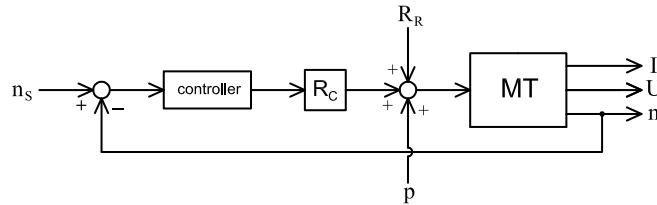

Figure 11: The simplified block diagram of a microturbine set speed control system: MT- microturbine set, n - rotational speed (n_s - set speed value), I - electric current, U - voltage, p - pressure at a turbine inlet, R_R - resistance of an electric power receiver, R_C - controlled resistance

system is shown in Figure 11. A controlled signal is a rotational speed, while a voltage and an current are resulting signals. A control system includes a summing node which compares a current speed signal with a set value. Based on a control error, a controller forms an input signal a controlled resistance. A working medium pressure at a turbine inlet and a resistance of electric power receivers are treated as a disturbances.

4.3. A microturbine set voltage control by changing a pressure at a turbine inlet

Figure 12 shows the experimentally determined static characteristics of the microturbine set working at the constant voltage. When the load resistance increases, the voltage value is kept constant by decreasing the working medium pressure at the turbine inlet and, consequently, the rotational speed of the microturbine rotor.

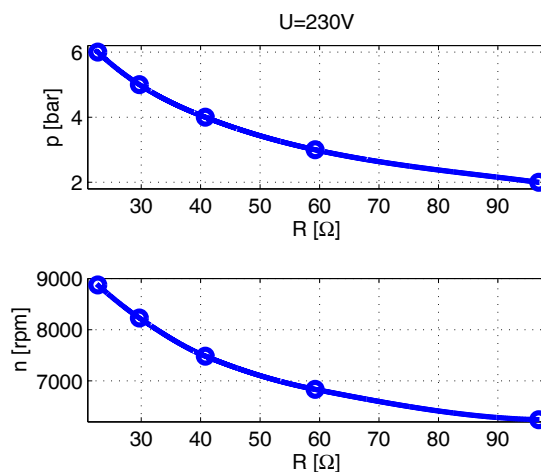

Figure 12: Pressure p at the turbine inlet and rotational speed n as functions of resultant load resistance R , for voltage $U = 230$ V

Accordingly, a voltage of a microturbine set can be controlled by changing the pressure at a turbine inlet. The schematic diagram of this control system is shown in Figure 13. A microturbine set delivers electric power to electric power receivers with resistance R . An electrical load can change during a microturbine set operation. A control valve is installed in front of a turbine. By throttling a flow of a working medium, a valve changes a pressure at a turbine inlet and, consequently, the remaining operating parameters of a microturbine set. Based on a current voltage value, a controller controls a valve in such a way that an output voltage of a generator is kept constant and equal to a set value.

The simplified block diagram of this type of control system is shown in Figure 14. A controlled signal is the voltage, while the electric current and rotational speed are the resulting parameters. An instantaneous voltage signal is compared with a set value at a summing node. Based on a control error, a voltage controller forms a signal for a control valve. A resistance of electric power receivers is considered as a disturbance.

4.4. A microturbine set voltage control using an additional resistor with controlled resistance

Figure 15 shows the experimentally determined static characteristic of the microturbine set. During the experiment, the voltage was kept constant by the proper resistance selection of the electric power receiver. After an increase

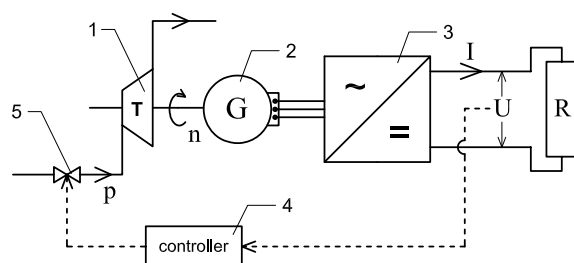

Figure 13: The schematic diagram of a voltage control system for a microturbine set; 1-turbine, 2-generator, 3-rectifying system, 4-microturbine set controller, 5-control valve, p-pressure at a turbine inlet, n-rotational speed, U-voltage, I-electric current, R-resistance of electric power receivers

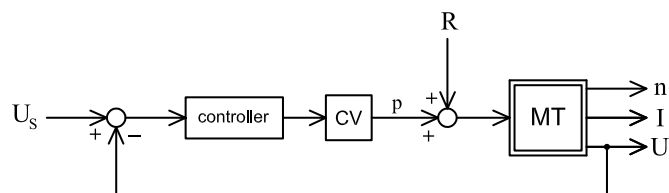

Figure 14: The simplified block diagram of a microturbine set voltage control system; MT - microturbine set, CV - turbine control valve, p - pressure at a turbine inlet, R - resistance of electric power receivers, n - rotational speed, U - voltage, I - electric current, U_s - set voltage value



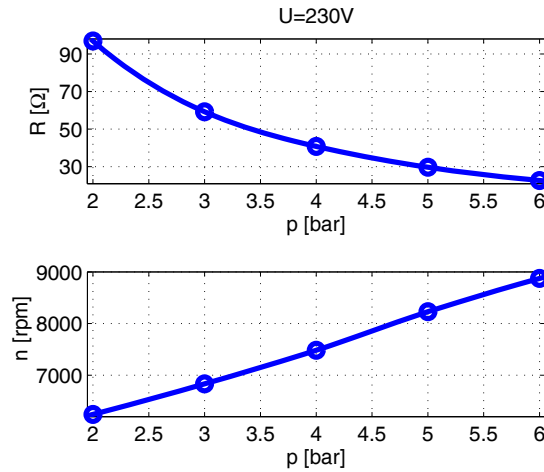

Figure 15: The resultant load resistance R and rotational speed n as functions of pressure p at a turbine inlet, for voltage $U = 230$ V of microturbine set

of the working medium pressure at the turbine inlet, the above resistance had to be decreased to maintain the constant voltage value. The pressure increase was accompanied by the simultaneous increase of the rotational speed.

Accordingly, a voltage of a microturbine set can be controlled by forming a resultant electrical load of a generator. The schematic diagram of this control system variant is shown in Figure 16. A microturbine set produces electrical energy consumed by a receiver (4) with resultant resistance R_R . A resistor (5) with controlled resistance R_C is installed in parallel with an electric power receiver. A structure of a controlled resistor makes it possible to change its resistance during a microturbine set operation. The task of a controlled resistor is to consume surplus energy produced by a microturbine set. A resultant resistance of a load is R . A signal controlling a resistance R_C is formed by a controller, based on an instantaneous voltage value, in such a way as to maintain a set output voltage of a microturbine generator regardless of a pressure at a turbine inlet and a resistance of electric power receivers.

The simplified block diagram of an automatic microturbine set control system is shown in Figure 17. The controlled output signal is a voltage, while the uncontrolled output signals are a rotational speed and an electric current. Instantaneous voltage values are compared with a set value at a summing node. When a control error occurs, a controller changes a signal

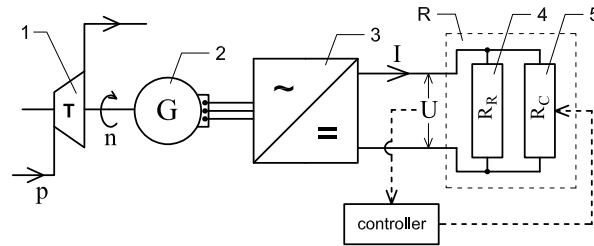

Figure 16: The schematic diagram of a voltage control system for a microturbine set: 1- turbine, 2- generator, 3- rectifying unit, 4- electric power receiver with resistance R_R , 5- resistor with controlled resistance R_C , n - rotational speed, p - pressure at a turbine inlet, I - electric current, U - voltage, R - resultant resistance of a generator load

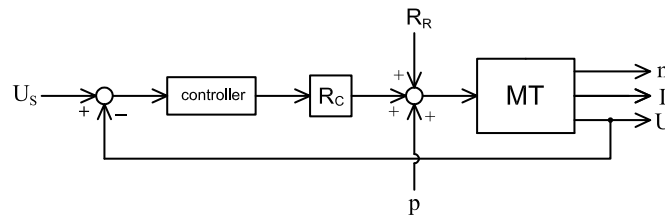

Figure 17: The simplified block diagram of a microturbine set control system: MT - microturbine set, n - rotational speed, I - electric current, U - voltage (U_S - set voltage value), p - pressure at a turbine inlet, R_R - resistance of power receiver, R_C - controlled resistance

for a controlled resistor in such a way as to maintain a set voltage value. Disturbances are a working medium pressure at a turbine inlet and a resistance of electric power receivers.

4.5. A microturbine set voltage and rotational speed control by changing a pressure at a turbine inlet and using an additional resistor with controlled resistance

Figure 18 shows the experimentally determined static characteristics of the microturbine set. The characteristics show the voltage as a function of rotational speed for different pressures at the turbine inlet. It also shows the marked resistance values of the generator load. It results from the presented characteristic that a given pair of rotational speed and voltage values corresponds to a pair of pressure and resistance values. Hence, we can state that maintaining the set values of a voltage and a rotational speed of a microturbine set is possible by keeping the constant relevant thermodynamic

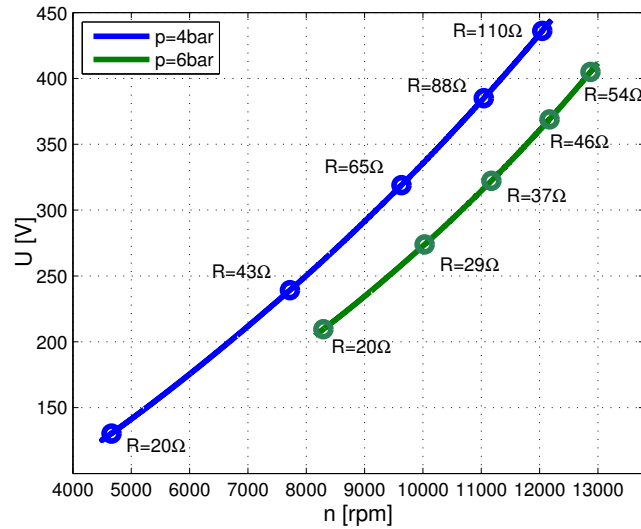

Figure 18: Voltage U as a function of rotational speed n for the microturbine set for the constant working medium pressure p at the turbine inlet, in relation to the load resistance R

parameters of a working medium at a turbine inlet and the relevant electric generator load. This can be done using a control valve at a turbine inlet and an additional resistor with the controlled resistance on a generator load side. The schematic diagram of this solution is shown in Figure 19. Electric power receivers are represented on the diagram by a resistor with resistance R_R (4), and an additional resistor with controlled resistance R_R (5), both connected in parallel. A resultant resistance of a microturbine set load is R . The structure of a controlled resistor makes it possible to change its resistance during operation. This way a required resistance value can be maintained regardless of a number of currently connected electric power receivers. Moreover, a control valve (7) is installed on a turbine supply pipeline. Based on instantaneous values of a rotational speed of a microturbine rotor and a voltage, a controller (6) forms input signals for a control valve and a controlled resistor in such a way as to maintain the set values of the controlled parameters.

The simplified block diagram of an automatic control system for a microturbine set is shown in Figure 20. The controlled parameters are a voltage and a rotational speed, while an uncontrolled output signal is an electric current. Instantaneous voltage and rotational speed values are compared with set values at the summing nodes. When a control error occurs, a controller

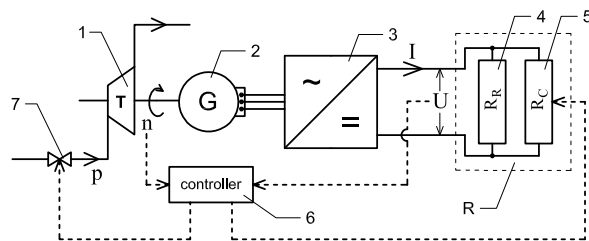

Figure 19: The schematic diagram of an automatic voltage and a rotational speed control system for a microturbine set; 1-turbine, 2-generator, 3-rectifying system, 4-electric power receiver with resistance R_R , 5-resistor with controlled resistance R_C , 6-microturbine set controller, 7-control valve, p-pressure at a turbine inlet, n-rotational speed, U-voltage, I-electric current, R-resultant resistance of a generator load

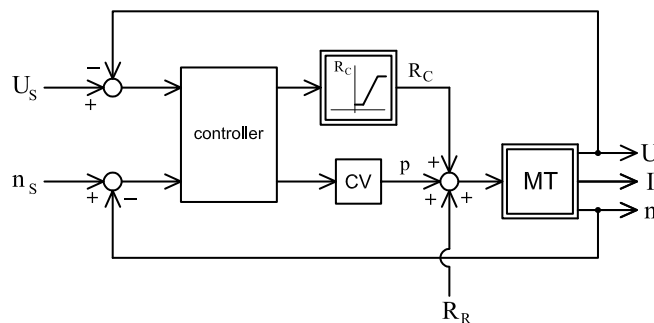

Figure 20: The simplified block diagram of an automatic microturbine set voltage and rotational speed control system; MT-microturbine set, CV-turbine control valve, p-pressure at a turbine inlet, R_R -resistance of electric power receivers, R_C -resistance of controlled resistor, n-rotational speed, U-voltage, I-electric current, U_s -set voltage value, n_s -set speed value

changes input signals for a turbine control valve and a controlled resistor in such a way as to maintain a set rotational speed and voltage values. A controlled resistor is shown on the diagram as a nonlinear object of a constraint type. A disturbing parameter is a resistance of electric power receivers.

5. Simulation tests of the automatic control system for the microturbine set

Simulation tests were performed for the selected variants of the automatic control system for the microturbine set. The purpose of the simulations was to check whether in the transient conditions the proposed control variants



can properly carry out their tasks.

Calculations were made for the alternative control method which consists in consuming surplus electric energy in the resistor with the controlled resistance. This type of vapour microturbine sets the regulation, for the co-generation applications, is not found in the literature. Two variants differing by the selection of the controlled signals were considered. The concepts were analysed in which the controlled signal was:

- rotational speed,
- output voltage.

Simulation tests were performed for the proportional-integral (PI) controller (due to its reliability, relatively simple structure and simplicity of implementation in practice [62]). The PI controller transfer function is:

$$G_c(s) = K\left(1 + \frac{1}{T_I s}\right) \quad (1)$$

where: K is the gain coefficient and T_I is the integral time.

The control systems analysis and design focuses on three primary objectives: producing the desired transient response, reducing steady-state errors and achieving stability [63]. The parameters of the controller were selected only in such a way as to obtain the stable operation of the control system. Stability was assessed on the basis of the phase portraits. The requirements for steady-state error and transient response of the control system were not specified so the controller was not tuned to obtain improvement in this regard.

The control system operation was tested in various conditions expected to occur in a real power plant operation.

In the simulation calculations, the empirical model of a vapour microturbine set was used. This model was developed and verified in [46].

5.1. The microturbine set rotor speed control using the additional resistor with controlled resistance

The block diagram of the control system of the microturbine set for which the simulation tests were performed is shown in Figure 21. The controlled signal is the rotational speed, while the voltage and the electric current are the resulting signals. The control system comprises the summing node which compares the speed signal with the set value. Based on the control error, the

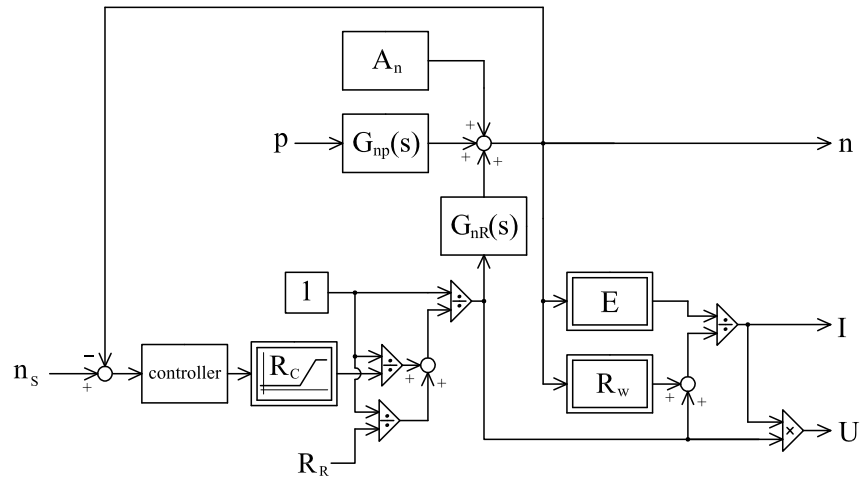

Figure 21: The block diagram of the model of the microturbine set control system: n - rotational speed (n_s - set value), I - electric current, U - voltage, p - turbine inlet pressure, R_R - resistance of power receiver, R_C - controlled resistance, $G_{np}(s)$, $G_{nR}(s)$ - transmittances, A_n - constant, E - equivalent electromotive force, R_w - equivalent internal resistance

controller forms the signal adjusting the controlled resistance. The element representing the resistor with the controlled resistance is taken into account as the object of the saturation type.

An exemplary phase portrait of the considered control system is shown in Figure 22.

Selected results of the performed simulations are shown in the diagrams. Figure 23 presents the changes of the basic operating parameters of the microturbine set cooperating with the rotational speed control system, after the step reduction of the electric power receiver resistance from 150Ω to 35Ω , at the turbine inlet pressure equal to 6 bar. The diagrams show the time-histories of such parameters as: the resistance of the electric power receiver, the controlled resistance, the rotational speed, the voltage, and the electric current. The set rotational speed value was 10000 rpm. Simulation calculations were performed for the controller gain coefficient $K = 0,2 [-]$ and integral time $T_I = 1,5$ s. Before the change of the electric power receiver resistance, the microturbine set worked at the rotational speed equal to 10000 rpm, while the resistance of the controlled resistor was 39Ω , the voltage was 286 V, and the electric current was 9,3 A. After the step change of the load, the rotational

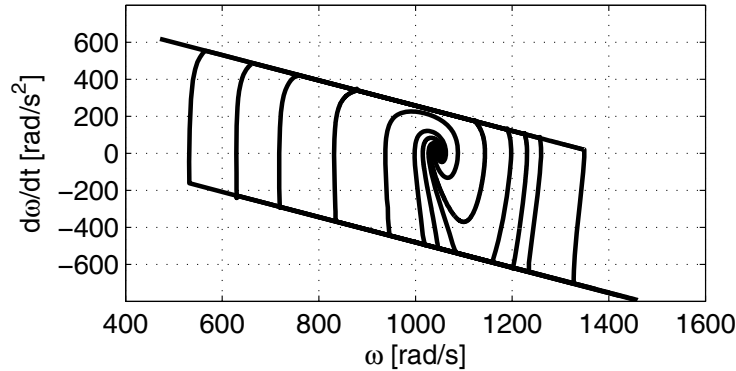

Figure 22: The phase portrait of the microturbine set control system, ω - angular speed, t - time

speed began to decrease gradually. In response to the appearance of the difference between the instantaneous rotational speed value and its set value, the control system began to change the resistance of the controlled resistor. After 9 seconds, the rotational speed returned to the set value. In the transient time interval, the largest difference between the instantaneous and set rotational speed values was equal to 188 rpm. When the microturbine set returned to the steady state, the resistance of the controlled resistor was equal to 249Ω , while in the transient time interval it instantaneously increased to 371Ω . At the time of the step change of the electric power receiver resistance, the electrical parameters of the microturbine set also changed rapidly: the voltage decreased to 238 V, while the electric current increased to 13 A. When the microturbine set reached the steady state again, the electrical parameters also returned to the values from before the step change of the load. The responses of the microturbine set and the control system to the step increase of the load resistance back to 150Ω are shown in Figure 24. After the load change, the rotational speed gradually increased to 10564 rpm, and then decreased to 10000 rpm. The resistance of the controlled resistor decreased initially to 4Ω and then increased to the steady level of 39Ω . Directly after the step change of the load, the voltage increased rapidly to 358 V, and then decreased gradually to 88 V, to increase again to 286 V. The electric current decreased rapidly to 3,8 A, then increased to 24,6 A, and decreased again to 9,3 A. In this case, the adjustment time was equal to 1,4 sec.

It was observed that in the transient time interval following the change of the electric power receiver resistance, the electric current value can tem-

porarily increase. This phenomenon is especially noticeable after decreasing the load, with the resultant instantaneous rotational speed increase and the decrease of the controller resistor resistance. In the simulation shown in Figure 24, the instantaneous electric current value after the load decrease was approximately equal to 25 A. This value of electric current can be dangerous for generator winding durability; therefore a proposal has been made to equip such a control system with a special unit protecting the system against the electric current increase above the set value.

The schematic diagram presenting the microturbine set control system with the overcurrent protection unit is shown in Figure 25. This control system comprises an additional positive electric current feedback path, in which the nonlinear element with insensitivity zone is installed. This element activates the protection unit when the set electric current value is exceeded. A block diagram of the proposed control system variant for which the simulation tests were performed is shown in Figure 26. The selected results of the performed simulations are shown in diagrams which present the time-histories of such parameters as: resistance of electric power receiver, controlled resistance, rotational speed, voltage, electric current, and working medium pressure at the turbine inlet. The tests were performed for the set rotational speed of 10000 rpm and controller settings: $K=0,2 [-]$ and $T_I=1,25$ s. The overcurrent protection unit was activated after exceeding 10 A. For comparison purpose, the diagrams present the results for the control system with and without overcurrent protection.

Figure 27 shows the responses of the microturbine set and the control system after the step decrease of the electric power receiver resistance from 150Ω to 35Ω , at the working medium pressure at the turbine inlet equal to 6 bar. Before the load change, the microturbine set worked at the rotational speed equal to 10000 rpm, while the output voltage was 286 V, the electric current was 9,3 A, and the resistance of the controlled resistor was 39Ω . Changing the control system variant did not affect significantly the course of the rotational speed signal. Before the set current value was exceeded, the rotational speed instantaneously decreased to 9893 rpm in the variant without the overcurrent protection, and to 9890 rpm with the protection. In both cases the transient time interval between the load change and reaching the steady state of the microturbine set operation was equal to 4 sec. Substantial differences were observed in the time-histories of the electrical parameters. At the time of the step load change, the voltage in the variant without protection decreased to 239 V and the electric current increased to 13 A, while in the variant with

protection the voltage decreased to 266 V and the electric current increased to 10,9 A. Differences in control system responses can also be observed in the time-histories of the controlled resistor resistance signal. After the step reduction of the electric power receiver resistance, in the variant without protection the resistance of the controlled resistor gradually increased to 270 Ω and then decreased to 252 Ω , while in the system with overcurrent protection this resistance increased rapidly to 82 Ω and then changed in a similar way as in the variant without protection.

Figure 28 shows the simulation results for the step increase of the electric power receiver resistance from 35 Ω to 150 Ω , at the working medium pressure at the turbine inlet equal to 6 bar. Before the load change, the microturbine set worked at the rotational speed equal to 10000 rpm, while the output voltage was 286 V, and the electric current was 9,3 A. In both cases the time after which the microturbine set reached the steady state after the load change was equal to 1,3 sec. At the steady state before and after the electric power receiver resistance change, such parameters as rotational speed, voltage and electric current took the same values. At the time of the load change, in both control system variants the electric current rapidly decreased to 3,8 A, and then began to increase gradually. In the system variant without protection, the electric current increased to 20,8 A, while in the other system, the overcurrent protection unit was activated after exceeding 10 A and limited to the instantaneous electric current increase to 13,2 A. In both cases, the voltage increased rapidly to 358 V, and then instantaneously decreased to 141 V and 245 V in the variant without and with protection, respectively. Finally, the voltage and the electric current gradually returned to their steady-state values. In both cases, the maximal rotational speed value in the transient time interval was equal to 10592 rpm. The minimal value of the controlled resistor resistance in the transient time interval was equal to 7 Ω and 21 Ω in the variant without and with protection, respectively. At the steady state after the load change, this resistance reached the value of 39 Ω .

Figure 29 shows the simulation results for the step decrease of the working medium pressure at the turbine inlet, which rapidly decreased from 6 bar to 5 bar, at the electric power receiver resistance equal to 60 Ω . Before the pressure change, the microturbine set worked at the rotational speed equal to 10000 rpm, while the voltage was 286 V, the electric current was 9,3 A, and the resistance of the controlled resistor was 63 Ω . During the test, the electric current did not exceed 10 A, consequently the protection unit was not activated and the time-histories of the microturbine set and control system



operation parameters were identical for both variants. After the pressure decrease, the rotational speed began to decrease, the voltage began to increase, and the electric current began to decrease (the extreme values of these parameters in the transient time interval were equal to: 9815 rpm, 321 V, and 6,7 A, respectively). In response to the rotational speed change, the control system began to increase gradually the resistance of the controlled resistor (the maximal value in the transient time interval was equal to 235 Ω). After 6 seconds, the microturbine set reached the steady state with the following values of the operating parameters: rotational speed 10000 rpm, voltage 316 V, and electric current 7 A, at the controlled resistor resistance equal to 181 Ω .

Figure 30 shows the simulation results for the step increase of the working medium pressure at the turbine inlet, which rapidly increased from 5 to 6 bar, at the electric power receiver resistance equal to 60 Ω . Before the pressure change, the microturbine set worked at the rotational speed equal to 10000 rpm, while the output voltage was 316 V, the electric current was 7 A, and the resistance of the controlled resistor was 181 Ω . After the pressure change, the rotational speed increased gradually to 10239 rpm, and then decreased to the set value. The time-histories of the rotational speed signal did not differ substantially after changing the control system variant. After the pressure change, the electric current increased gradually to 11,3 A in the control system variant without protection, and to 10,7 A in the variant with protection. Then the current decreased to 9,3 A in the steady state. The voltage decreased to 271 V and 263 V in the variant without and with protection, respectively, and then increased to 286 V in the steady state. The resistance of the controlled resistor decreased in the transient time interval, to 38 Ω in the variant without protection and to 44 Ω with protection. The steady-state value of this resistance was 63 Ω . After the inlet pressure change, the new steady state of the microturbine set operation was reached after 2,5 sec.

The performed simulation tests have presented the performance of the microturbine set cooperating with the rotational speed control system in the conditions of the step change of the load or working medium pressure at the turbine inlet. In all examined cases, based on the control error the controller adjusted the resistance of the controlled resistor in such a way as to maintain the set rotational speed value. If the change of load or working medium pressure resulted in the increase of the rotational speed, then the control system decreased the resistance of the controlled resistor, and if the rotational speed decreased then the resistance of the controlled resistor was



increased. After the load change, in the steady state, such parameters of the microturbine set operation as voltage and electric current took the same values as before the change. If the pressure was changed at the constant load, the voltage and electric current also changed. Being the controlled parameter, the rotational speed had always the same value in the steady states.

The obtained results demonstrated the performance of the control system with a special unit intended to protect the generator windings against exceeding the permissible electric current limit. The overcurrent protection unit activities aimed at limiting the electric current increase when the microturbine load changed or the turbine inlet pressure increased. When this pressure decreased (at a constant resistance of the electric power receiver) the electric current also decreased and the protection unit was not activated. In this case, the protection unit did not affect the time-histories of the basic parameters of the microturbine set operation. In all examined cases, the protection unit did not affect significantly the course of the controlled parameter (rotational speed).

5.2. The microturbine set voltage control using the additional resistor with the controlled resistance

The concept was analysed of the automatic microturbine set output voltage control by forming the resultant generator load.

The block diagram of the microturbine set control system for which the simulation tests were performed is shown in Figure 31. The controlled signal is the generator output voltage, while the rotational speed and the electric current are the resulting signals. The control system includes the summing node which compares the voltage signal with the set value. Based on the control error, the controller forms the signal adjusting the controlled resistance. The element representing the resistor with the controlled resistance is taken into account as the object of the saturation type.

The voltage control system simulation calculations were performed for the PI controller with the following parameters:

- $K = 0,1 [-]$ - controller gain coefficient,
- $T_I = 6 [s]$ - controller integral time.

The set voltage value assumed in the simulation calculations was equal to 220 V.

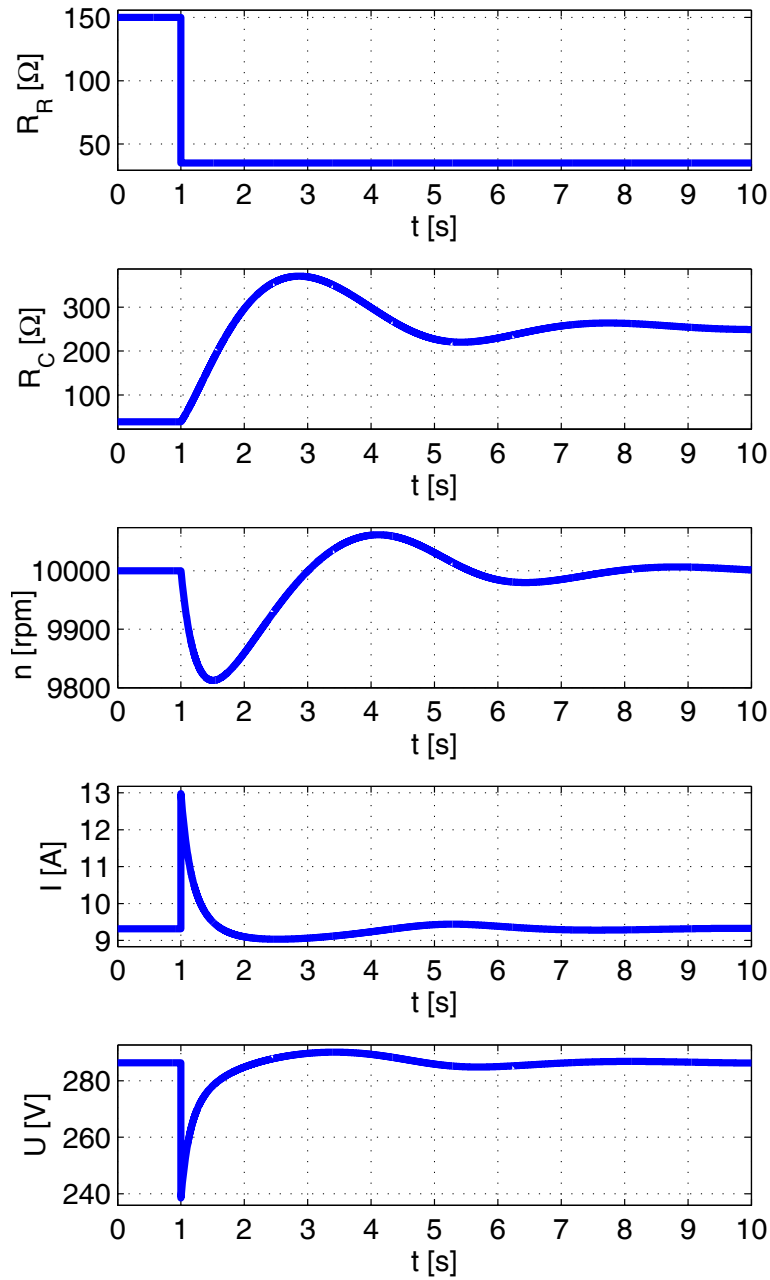

Figure 23: The response of the control system with the PI controller to step reduction of electric power receiver resistance: R_R - resistance of electric power receiver, R_C - resistance of controlled resistor, n - rotational speed, I - electric current, U - voltage



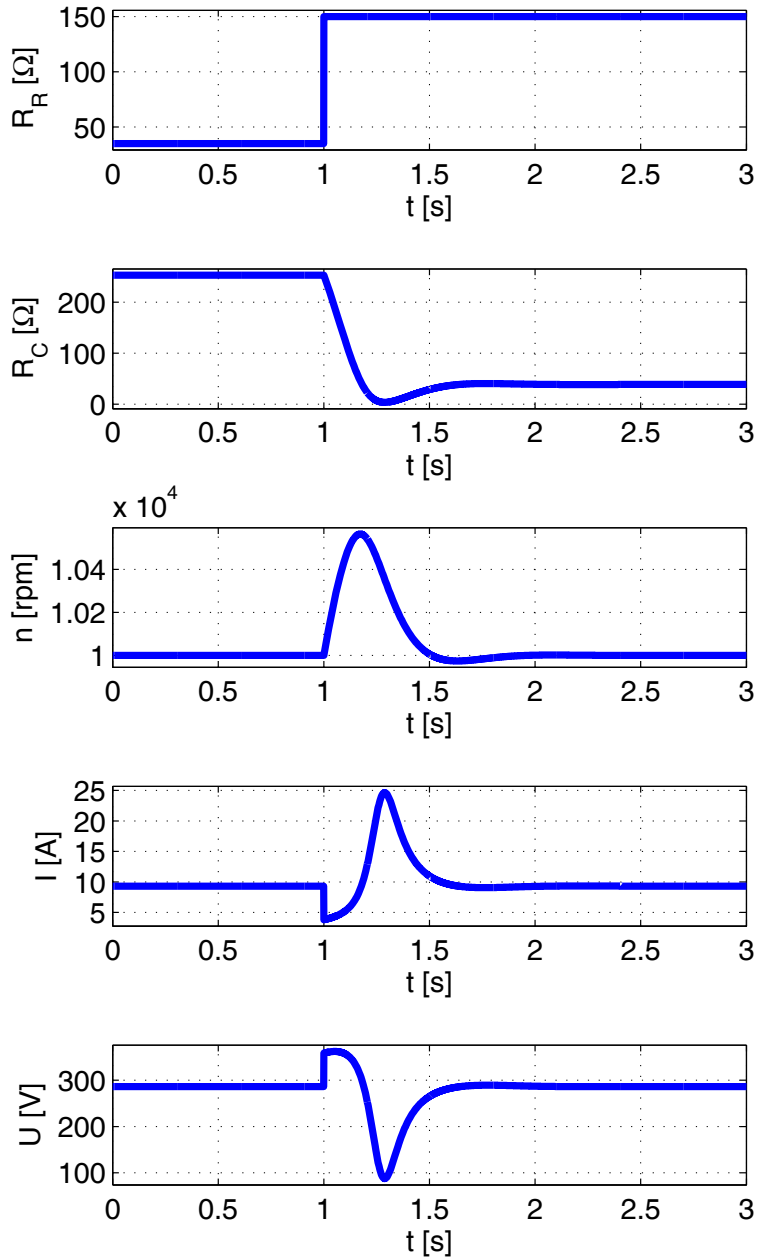

Figure 24: The response of the control system with the PI controller to the step increase of the electric power receiver resistance: R_R - resistance of electric power receiver, R_C - resistance of controlled resistor, n - rotational speed, I - electric current, U - voltage

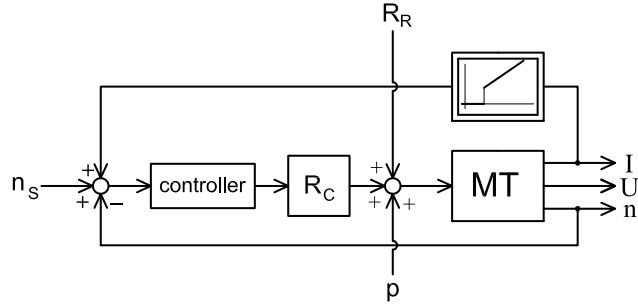

Figure 25: The simplified block diagram of the automatic microturbine set control system with the overcurrent protection unit: MT- microturbine set, n-rotational speed (n_S -set value), I- electric current, U- voltage, p- turbine inlet pressure, R_R - resistance of power receiver, R_C - resistance of controlled resistor

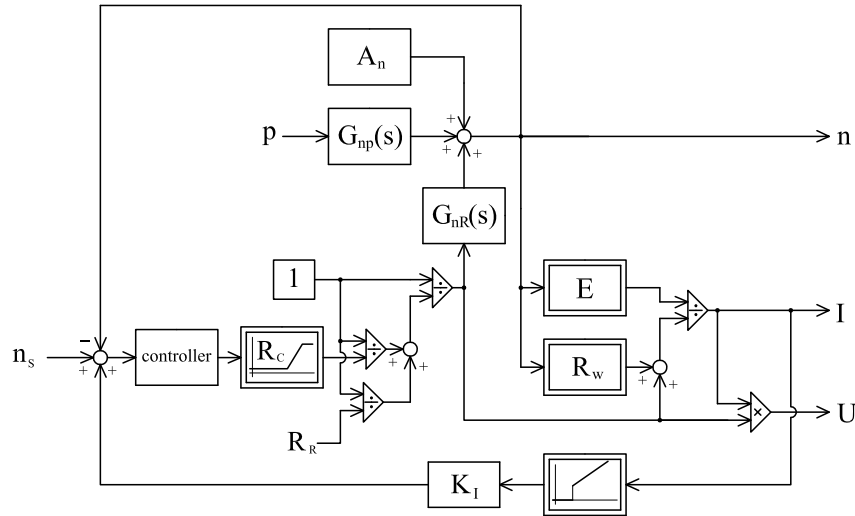

Figure 26: The block diagram of the automatic microturbine set control system with the overcurrent protection unit: n-rotational speed (n_S -set value), I- electric current, U- voltage, p- turbine inlet pressure, R_R - resistance of electric power receiver, R_C - resistance of controlled resistor, $G_{np}(s)$, $G_{nR}(s)$ - transmittances, A_n - constant, E- equivalent electro-motive force, R_w - equivalent internal resistance, K_I - electric current feedback path gain coefficient

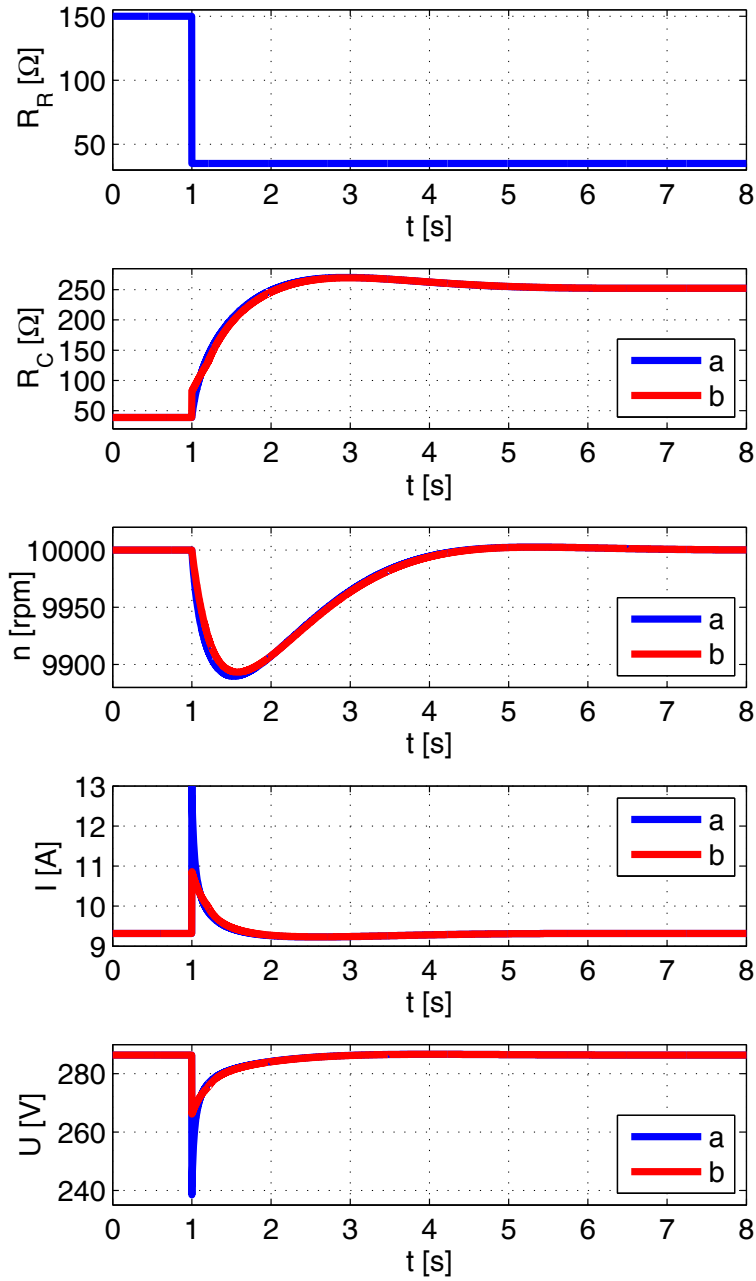

Figure 27: The response of the control system with the PI controller to step decrease of electric power receiver resistance, with and without overcurrent protection: R_R - resistance of electric power receiver, R_C - resistance of controlled resistor, n - rotational speed, I - electric current, U - voltage, a - system without electric current limit, b - system with electric current limit

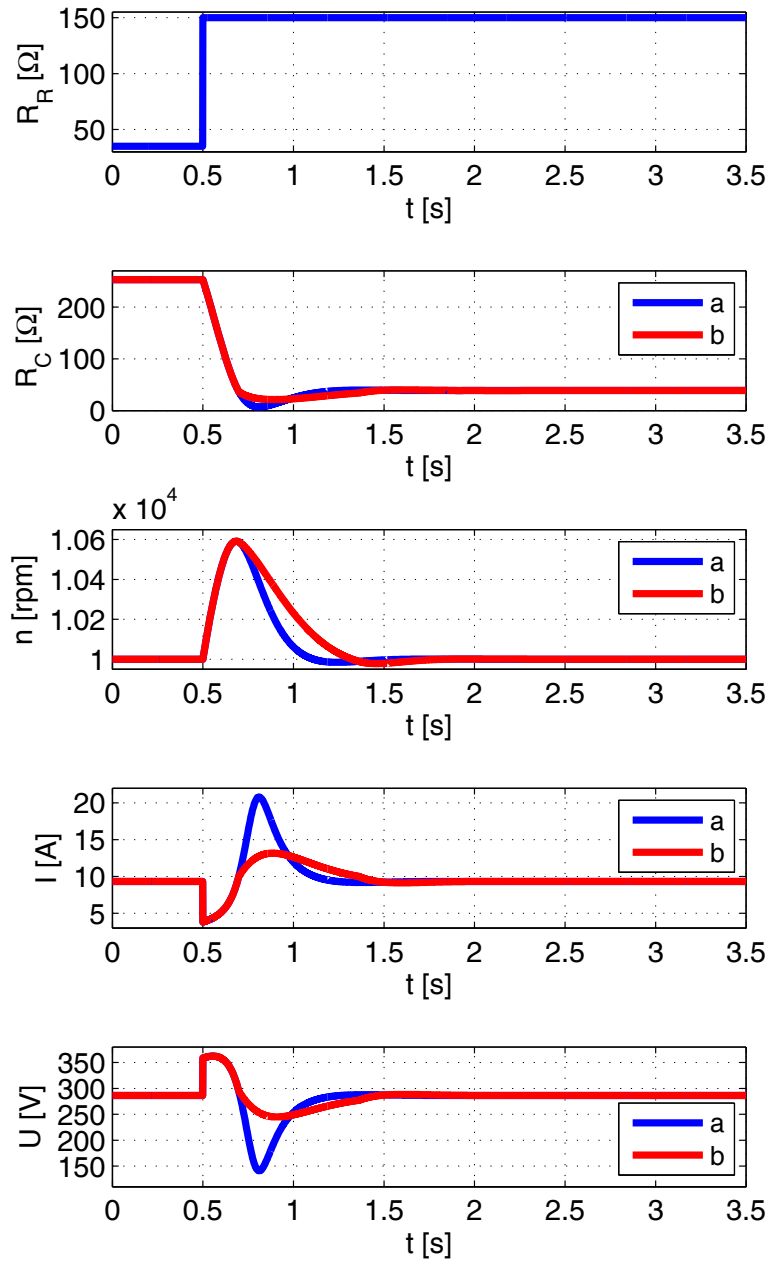

Figure 28: The response of the control system with the PI controller to the step increase of the electric power receiver resistance, with and without overcurrent protection: R_R - resistance of electric power receiver, R_C - resistance of controlled resistor, n - rotational speed, I - electric current, U - voltage, a - system without electric current limit, b - system with electric current limit

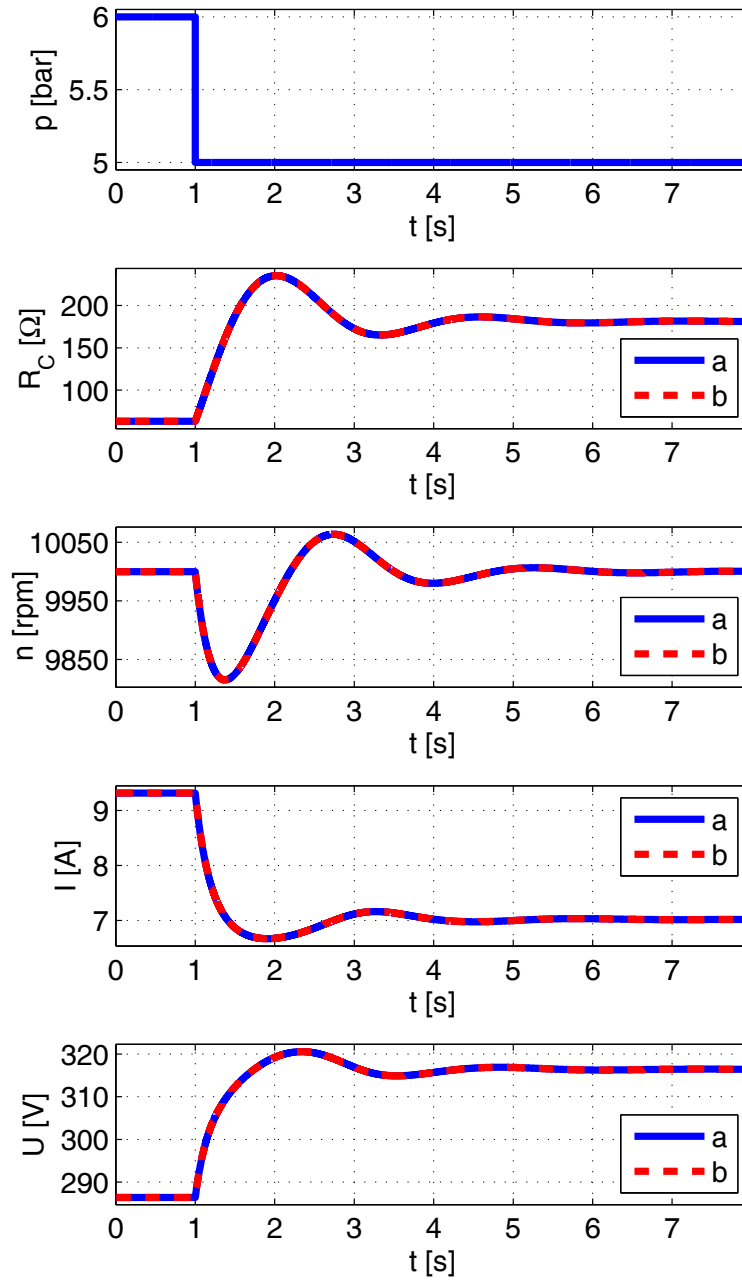

Figure 29: The response of the control system with the PI controller to the step decrease of the turbine inlet pressure, with and without overcurrent protection: p -working medium pressure at the turbine inlet, R_C -resistance of controlled resistor, n -rotational speed, I -electric current, U -voltage, a-system without electric current limit, b-system with electric current limit



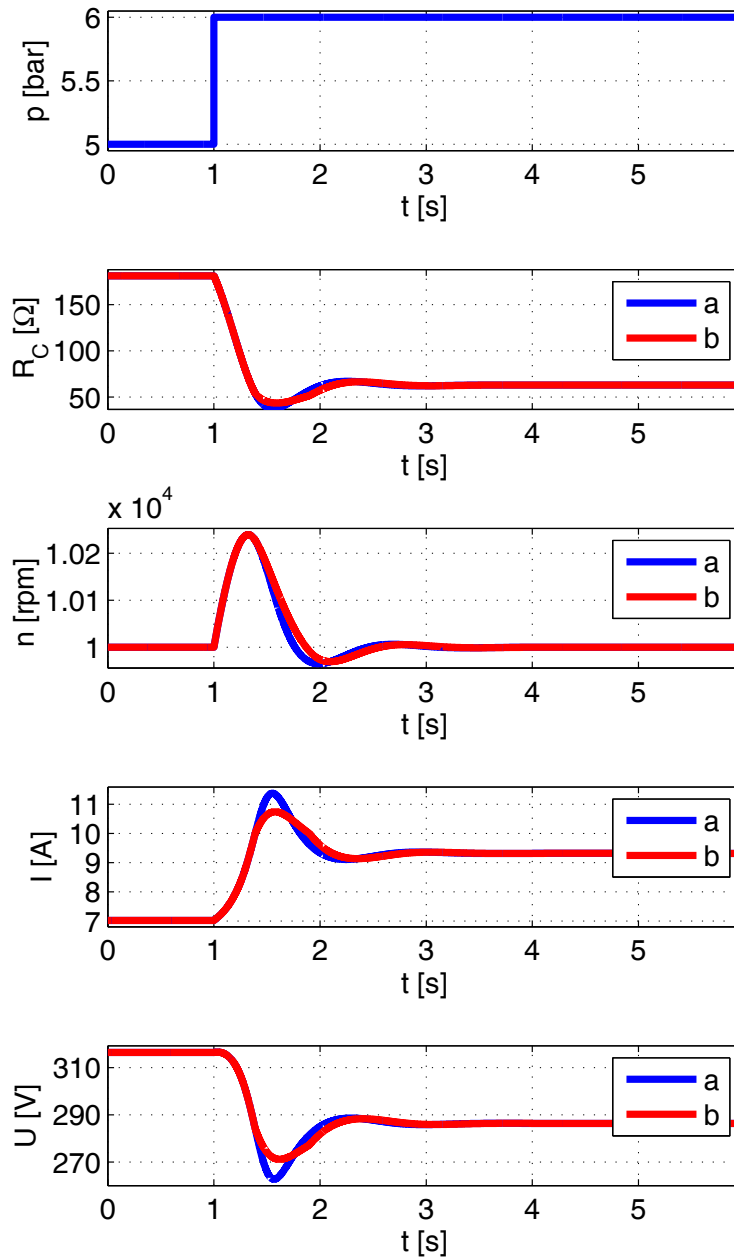

Figure 30: The response of the control system with the PI controller to the step increase of the turbine inlet pressure, with and without overcurrent protection: p-turbine inlet pressure, R_C - resistance of controlled resistor, n-rotational speed, I-electric current, U-voltage, a-system without electric current limit, b-system with electric current limit

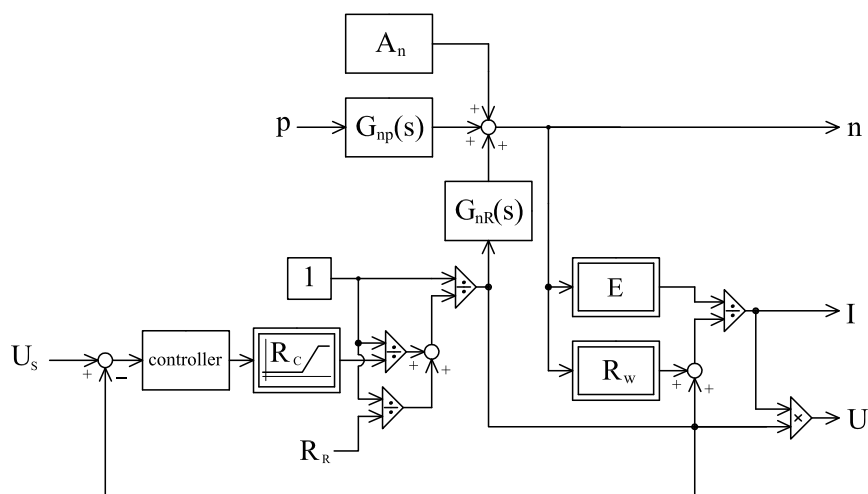

Figure 31: The block diagram of the microturbine set control system: n -rotational speed, I -electric current, U -voltage (U_s -set voltage value), p -turbine inlet pressure, R_R -resistance of electric power receiver, R_C -resistance of controlled resistor, $G_{np}(s)$, $G_{nR}(s)$ -transmittances, A_n -constant, E -equivalent electromotive force, R_W -equivalent internal resistance

As the first step, the control system operation was checked in the conditions of the step change of the microturbine set load.

Figure 32 shows the calculated time-histories of the basic parameters of the microturbine set cooperating with the voltage control system, after the step decrease of the electric power receiver resistance from 150Ω to 35Ω , at the turbine inlet pressure equal to 6 bar. Before the load change, the microturbine set worked at the rotational speed equal to 8530 rpm, while the voltage was 220 V, the electric current was 11,2 A, and the resistance of the controlled resistor was 23Ω . After the step change of the electric power receiver resistance, the voltage dropped rapidly from the set value of 220 V down to 196 V, while the electric current increased rapidly to 13,4 A. At the same time, the rotational speed began to decrease gradually. In response to the voltage drop below the set value, the control system began to increase gradually the resistance of the controlled resistor, which allowed the voltage to return to the set value after 4 seconds. In the transient time interval, the rotational speed reached the minimal value of 8479 rpm. At the steady state following the step change of the load, the electric current and the rotational speed returned to the same values as before the excitation,

while the resistance of the controlled resistor increased to $44\ \Omega$.

The results of the simulations performed for the step increase of the electric power receiver resistance from $35\ \Omega$ to $150\ \Omega$, at the turbine inlet pressure equal to 6 bar, are shown in Figure 33. This time, in response to the set excitation the voltage increased rapidly from 220 V to 256 V, while the electric current rapidly dropped down from 11,2 A to 8 A. At the same time, the rotational speed increased gradually to 8609 rpm. The control system responded by decreasing the controller resistor resistance to $23\ \Omega$, as a result of which the voltage and the electric current returned after 4 seconds to the values from excitation.

The performance of the microturbine set voltage control system in the conditions of the step increase of the turbine inlet pressure from 5 bar to 6 bar is shown in Figure 34. The simulation calculations were performed at the electric power receiver resistance equal to $60\ \Omega$. At the beginning of the test, the resistance of the controlled resistor was $47\ \Omega$, the rotational speed was 7551 rpm, the electric current was 8,3 A, and the voltage was 220 V. After the increase of the turbine inlet pressure, the rotational speed, the electric current and the voltage began to increase gradually. At the transient state, the voltage reached the maximum value of 224 V. In response to the increasing control error, the controller began to decrease the controlled resistor resistance (to $29\ \Omega$ at the steady state), which after 5,5 seconds resulted in a voltage decrease to the set 220 V. At the steady state following the pressure increase, the rotational speed and electric current values were equal to 8530 rpm and 11,2 A, respectively.

The results of the simulations performed for the step decrease of the turbine inlet pressure from 6 bar to 5 bar, at the electric power receiver resistance equal to $60\ \Omega$, are shown in Figure 35. At the beginning of the test, the resistance of the controlled resistor was $29\ \Omega$, the rotational speed was 8530 rpm, the electric current was 11,2 A, and the voltage was 220 V. After the pressure decrease, the voltage initially decreased to 218 V, and then increased gradually to the set 220 V. At the steady state following the pressure decrease, the rotational speed and the electric current were equal to 7551 rpm and 8,3 A, respectively. The resistance of the controlled resistor increased to $47\ \Omega$. The time needed by the microturbine set to reach the steady state was equal to 5 sec.

The performed simulation calculations present the performance of the microturbine set cooperating with the voltage control system in the conditions of the step change of the load or the turbine inlet pressure. In all examined



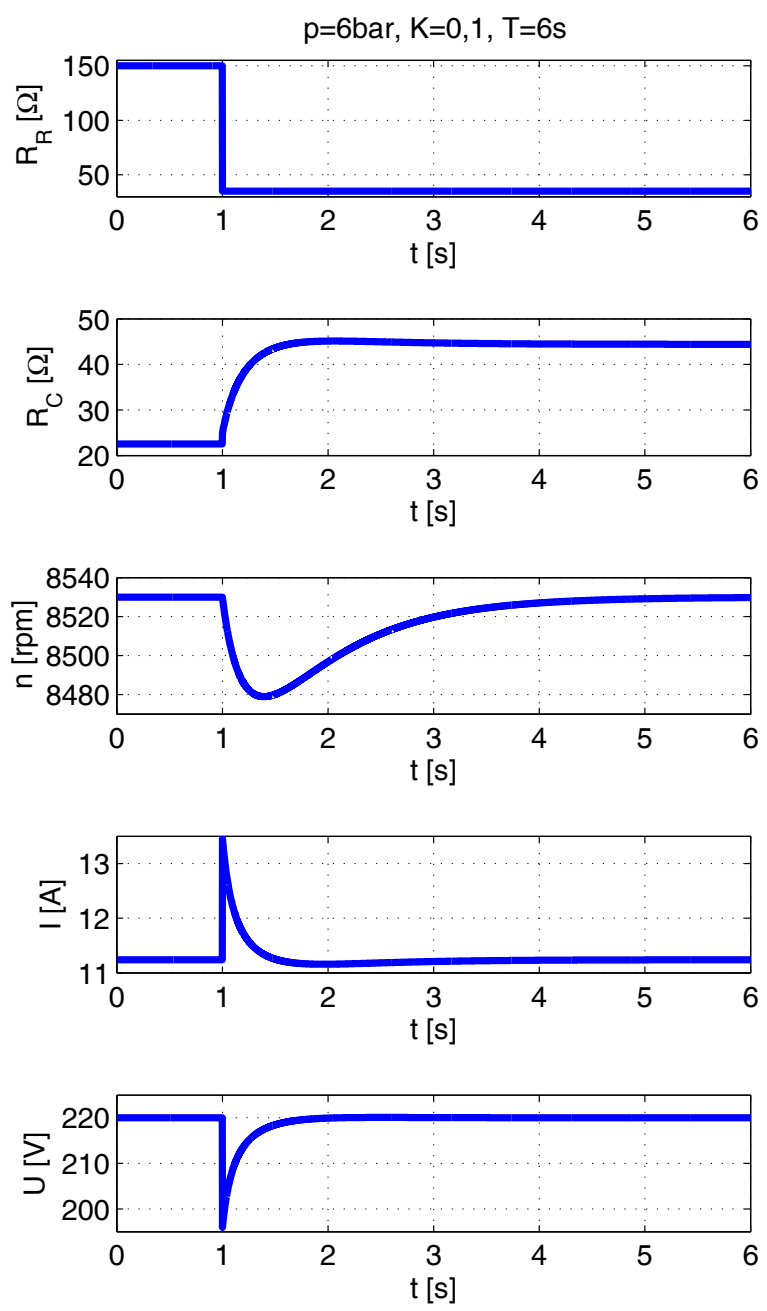

Figure 32: The response of the microturbine set control system to the step decrease of the electric power receiver resistance; p - turbine inlet pressure, K -controller gain coefficient, T -controller integral time, R_R -resistance of electric power receiver, R_C -resistance of controlled resistor, n -rotational speed, U - voltage, I -electric current

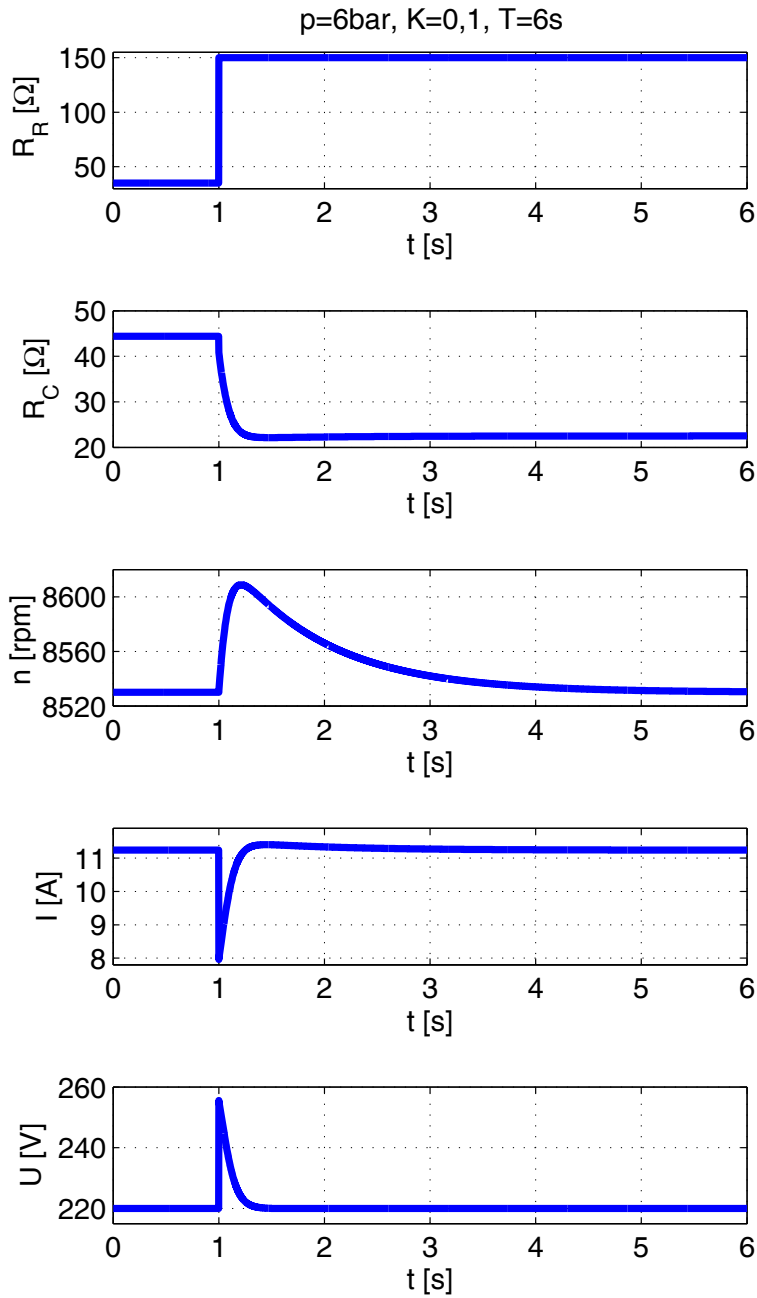

Figure 33: The response of the microturbine set control system to the step increase of the electric power receiver resistance; p - turbine inlet pressure, K -controller gain coefficient, T -controller integral time, R_R -resistance of electric power receiver, R_C -resistance of controlled resistor, n -rotational speed, U - voltage, I -electric current

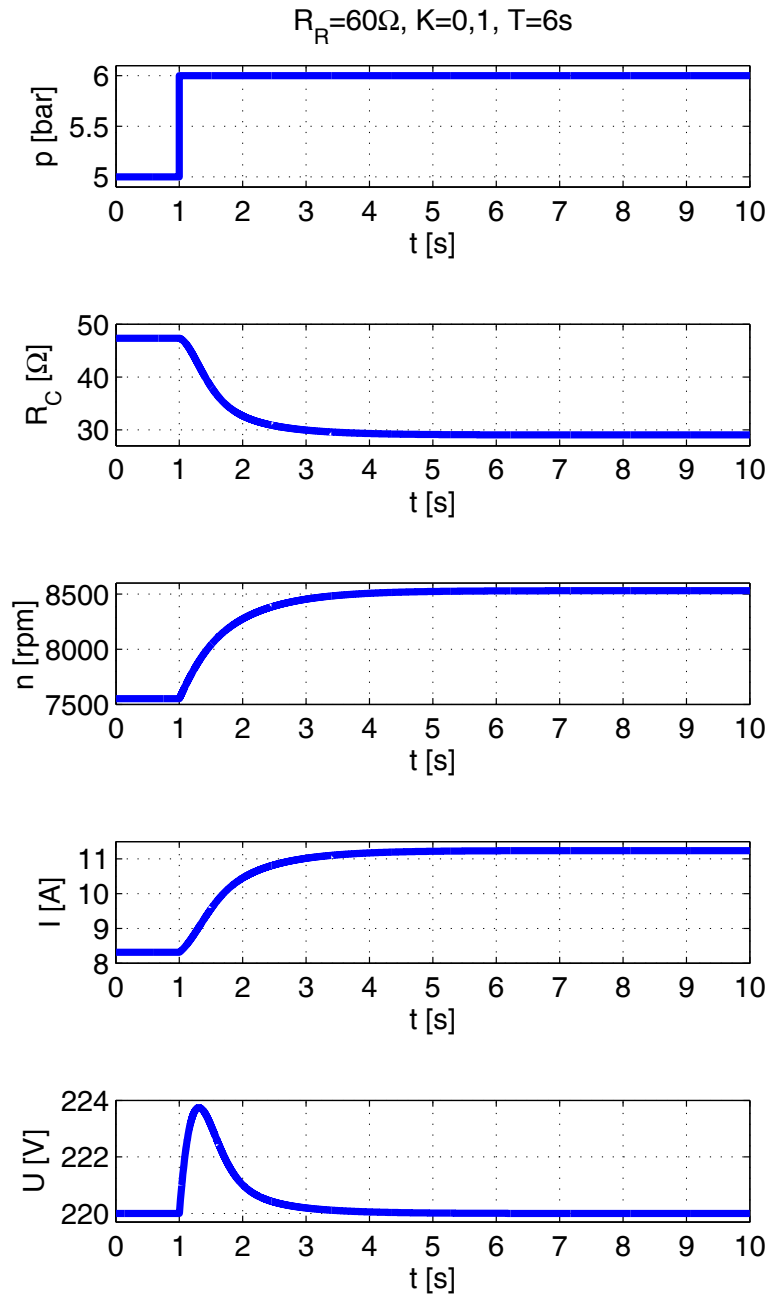

Figure 34: The response of the microturbine set control system to the step increase of the turbine inlet pressure; R_R - resistance of electric power receiver, K - controller gain coefficient, T - controller integral time, p - turbine inlet pressure, R_C - resistance of controlled resistor, n - rotational speed, U - voltage, I - electric current

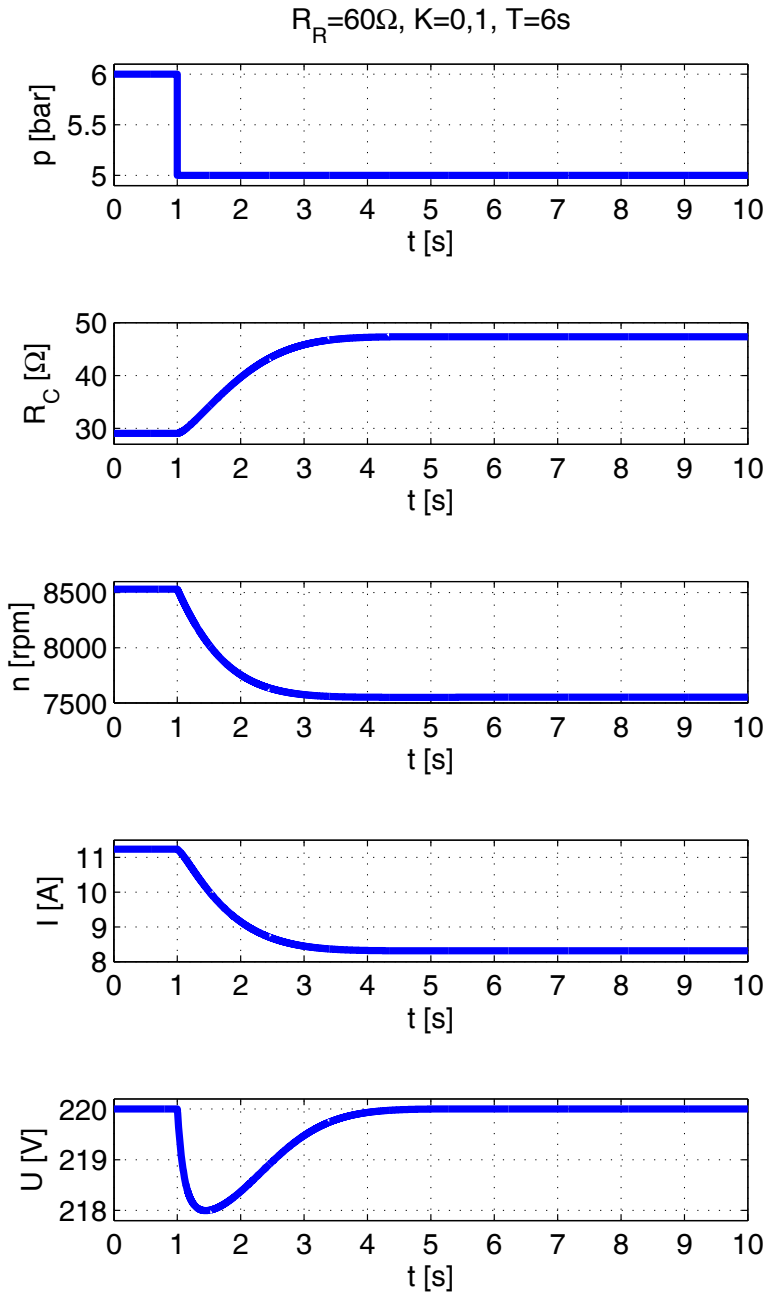

Figure 35: The response of the turbine set control system to the step decrease of the turbine inlet pressure; R_R - resistance of electric power receiver, K - controller gain coefficient, T - controller integral time, p - turbine inlet pressure, R_C - resistance of controlled resistor, n - rotational speed, U - voltage, I - electric current

cases, based on the control error the controller adjusted the resistance of the controlled resistor in such a way as to maintain the set voltage value. If the change of the load or working medium pressure resulted in the increase of voltage, then the control system decreased the resistance of the controlled resistor, and if the voltage decreased then the resistance of the controlled resistor was increased. At the steady state following the pressure increase, such microturbine set operation parameters as the rotational speed and the electric current took higher values than before the excitation. If the pressure was decreased, the rotational speed and the electric current also decreased.

6. Conclusions

Control concepts were analysed for vapour microturbine sets with generators with permanent magnets, intended to work in small heat and power plants. The analysed control system variants differed by the selection of controlled signals and set parameters. In some variants, the control system performed its tasks by throttling the working medium in the control valve situated at the turbine inlet. This method of microturbine sets control is similar to that used for controlling high power turbine sets. We should bear in mind, however, that in microturbine sets, the basic task of which is heat delivery, reducing the rate of working medium flowing through the turbine does not have to be equivalent with fuel consumption decrease. In this case, the flow rate of the working medium only depends on the demand for thermal energy, and its missing amount is to be delivered through the reduction and cooling station, leaving aside the turbine. That is why the alternative control method is proposed for microturbine sets, which consists in consuming the surplus electric energy in the resistor with controlled resistance. In this solution, in nominal operating conditions, the entire rate of the working medium flows through the turbine, and the reduction and cooling station is not used. This type of vapour microturbine sets control is not found in the literature. The proposed method gives the following benefits:

- eliminating the reduction and cooling station from the control system,
- reducing the number of control valves to one,
- the possibility of shortening the setting time (due to the elimination of thermal and flow phenomena from the control process),

Table 1: Possible ways of control of the vapour microturbine set with a generator with permanent magnets

controlled parameters	set parameters	actuators
rotational speed and voltage	pressure at turbine inlet and load on electric side	turbine control valve and resistor with controlled resistance
rotational speed	pressure at turbine inlet	turbine control valve
	load on electric side	resistor with controlled resistance
voltage	pressure at turbine inlet	turbine control valve
	load on electric side	resistor with controlled resistance

- the turbine operation at a constant load is advantageous for durability reasons.

Possible ways of control of microturbine sets with generators with permanent magnets are collated in Table 1.

The set rotational speed and voltage values can be maintained in the microturbine set by setting the working medium pressure at the turbine inlet and providing relevant microturbine generator load on the electric side. In this case, the control system actuators can be the turbine control valve and the resistor with the controlled resistance.

If the set value is only the working medium pressure at the turbine inlet, then the controlled parameter can be either the rotational speed or the voltage. This control can be performed using the control valve situated at the turbine inlet.

The set values of the rotational speed or the set voltage on generator terminals can also be maintained by controlling the microturbine generator load on the electric side. For those cases, a proposal is made to install an additional resistor with controlled resistance in parallel with other electric power receivers.

For two concepts of the control system, the simulation calculations were performed to check the system operation in various expected operating con-



ditions. These concepts differed by the selection of controlled signals, which were: the rotational speed or the output voltage. In both cases, the control system performed its task by changing the resistance of the controlled resistor connected in parallel with the electric power receiver. During the tests, the control systems correctly performed their tasks.

Based on the results of the performed simulation tests, a conclusion can be formulated that the consuming of surplus electrical energy in an additional energy receiver can be an effective method of vapour microturbine sets control, especially in domestic applications.

Acknowledgements

This research did not receive any specific grant from funding agencies in the public, commercial, or non-profit sectors.

Appendix A.

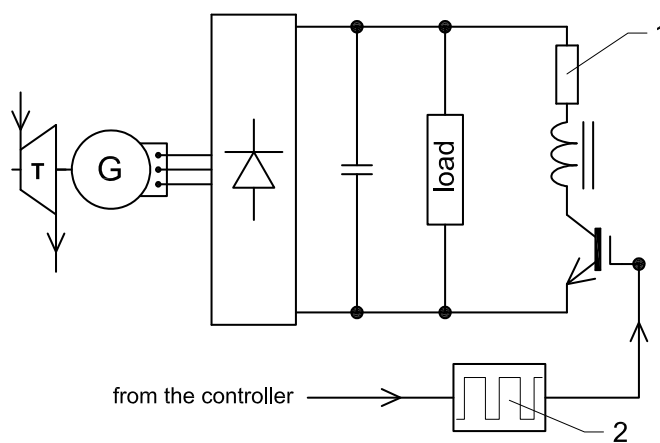

Figure A.36: The structure of the additional energy receiver with an option of effective resistance control, 1 - resistor, 2 - pulse generator

Figure A.36 shows the example of the system consuming surplus microturbine set electric energy. An additional resistor (1) is connected in parallel with the microturbine set load. The resultant resistance of the additional energy receiver is regulated by varying the IGBT transistor switch duty cycle. The operation of the transistor is controlled by the device (2) that converts

the signal from the microturbine set controller into a pulse signal with a variable width.

References

References

- [1] Zhu Y, Wang F, Yan J. The potential of distributed energy resources in building sustainable campus: The case of sichuan university. *Energy Procedia* 2018;145:582-85.
- [2] Medrano M, Brouwer J, McDonell V, Mauzey J, Samuelson S. Integration of distributed generation systems into generic types of commercial buildings in California. *Energy Build* 2008;40(4):537-48.
- [3] Yan J, Zhai Y, Wijayatunga P, Mohamed A, Campana P. Renewable energy integration with mini/micro-grids. *Applied Energy* 2017;201:241-44.
- [4] Wang C, Yan J, Marnay C, Djilali N, Dahlquist E, Wu J, Jia H. Distributed energy and microgrids (dem). *Applied Energy* 2018;210:685-89.
- [5] Liu X, Xu X, Liu C, et al. Heat transfer deterioration in helically coiled heat exchangers in trans-critical CO₂ Rankine cycles. *Energy* 2018;147:1–14.
- [6] Wajs J, Mikielwicz D, Fornalik-Wajs E. Thermal performance of a prototype plate heat exchanger with minichannels under boiling conditions. *Journal of Physics Conference Series* 2016;745:032063.
- [7] Wajs J, Mikielwicz D, Fornalik-Wajs E, Bajor M. Recuperator with microjet technology as a proposal for heat recovery from low-temperature sources. *Archives of Thermodynamics* 2015;36:48-63.
- [8] Mikielwicz D, Mikielwicz J, Wajs J. Experiences from operation of different expansion devices for application in domestic micro CHP. *Archives of Thermodynamics* 2010;31:3–13.
- [9] Xia G-D, Zhang Y-Q, Wu Y-T, et al. Experimental study on the performance of single-screw expander with different inlet vapor dryness. *Applied Thermal Engineering* 2015;87:34-40.



- [10] Yun E, Kim HD, Yoon SY, Kim AC. Development and characterization of small-scale ORC system using scroll expander. *Applied Mechanics and Materials* 2013;291-294:1627-30.
- [11] Lampart P, Kosowski K, Piwowarski M, Jedrzejewski L. Design analysis of Tesla micro-turbine operating on a low-boiling medium. *Polish Maritime Research* 2009;Special issue S1:28-33.
- [12] Mikielwicz J, Piwowarski M, Kosowski K. Design analysis of turbines for co-generating micro-power plant working in accordance with organic Rankine's cycle. *Polish Maritime Research* 2009;Special issue S1:34-8.
- [13] Piwowarski M, Kosowski K. Design analysis of combined gas-vapour micro power plant with 30 kW air turbine. *Polish Journal of Environmental Studies* 2014;23:1397-1401.
- [14] Dutra J C, Gonzalez-Carmona M A, Lazaro-Alvarado A F, Coronas A. Modeling of a Cogeneration System with a Micro Gas Turbine Operating at Partial Load Conditions. *Journal of Sustainable Development of Energy, Water and Environment Systems* 2017;5:139-50.
- [15] Kosowski K. Steam and gas turbines. Principles of operation and design. France, Swiss, Great Britain, Poland: ALSTOM; 2007.
- [16] Kosowski K. Steam and gas turbines. Power plants. France, Swiss, Great Britain, Poland: ALSTOM; 2007.
- [17] Massardo A F, McDonald C F, Korakianitis T. Micro-turbine/Fuel-Cell Coupling for High-Efficiency Electrical-Power Generation. *Transactions of the ASME, Journal of Engineering for Gas Turbines and Power* 2002;124:110-16.
- [18] Campanari S, Boncompagni L, Macchi E. Microturbines and Trigeneration: Optimization Strategies and Multiple Engine Configuration Effects. *Journal of Engineering for Gas Turbines and Power* 2004;126:92-101.
- [19] Campanari S, Macchi E. Technical and Tariff Scenarios Effect on Microturbine Trigenerative Applications. *Journal of Engineering for Gas Turbines and Power*. 2004;126:581-89.



- [20] Colombo L. P. M., Armanasco F., Perego O. Experimentation on a Cogenerative System Based on a Microturbine. *Applied Thermal Engineering*. 2007;27:705-11.
- [21] Ho J. C., Chua K. J., Chou S. K. Performance study of a microturbine system for cogeneration application. *Renewable Energy* 2004;29:1121-33.
- [22] Logan Earl, Jr., Roy R. *Handbook of Turbomachinery*. Second Edition. New York: Arizona State University, Marcel Dekker Inc.; 2003.
- [23] Stepniak D., Piwowarski M. Analysing selection of low-temperature medium for cogeneration micro power plant. *Polish Journal of Environmental Studies* 2014;23:1417-21.
- [24] Saeid Mohammadzadeh Bina, Saeid Jalilinasrabad, Hikari Fujii. Energy, economic and environmental (3E) aspects of internal heat exchanger for ORC geothermal power plants. *Energy* 2017;140:1096-1106.
- [25] Piwowarski M. Design analysis of ORC micro-turbines making use of thermal energy of oceans. *Polish Maritime Research* 2013;20:48-60.
- [26] Mills D. Advances in solar thermal electricity technology. *Solar Energy* 2004;76:19-31.
- [27] Nelson J., Johnson N. G., Doron P., Stechel E. B. Thermodynamic modeling of solarized microturbine for combined heat and power applications. *Applied Energy* 2018;2012:592-606.
- [28] Dumont O., Dickes R., De Rosa M., et al. Technical and economic optimization of subcritical, wet expansion and transcritical Organic Rankine Cycle (ORC) systems coupled with a biogas power plant. *Energy Conversion and Management* 2018;157:294-306.
- [29] Mikielewicz D., Waajs J., Ziolkowski P., Mikielewicz J. Utilisation of waste heat from the power plant by use of the ORC aided with bleed steam and extra source of heat. *Energy* 2016;97:11-19.
- [30] Qiu G., Shao Y., Li J., Liu H., Riffat S. Experimental investigation of a biomass-fired ORC-based micro-CHP for domestic applications. *Fuel* 2012;96:374-82.



- [31] Wajs J, Mikielwicz D, Jakubowska B. Performance of the domestic micro ORC equipped with the shell-and-tube condenser with minichannels. *Energy* 2018;157:853-861. doi: 10.1016/j.energy.2018.05.174
- [32] Landelle A, Tauveron N, Haberschill P, et al. Organic Rankine cycle design and performance comparison based on experimental database. *Applied Energy* 2017;204:1172-87.
- [33] Dulau M, Bica D. Simulation of Speed Steam Turbine Control System. *Procedia Technology* 2014;12:716-22.
- [34] Maddalena Pondini, Valentina Colla, Annamaria Signorini. Models of control valve and actuation system for dynamics analysis of steam turbines. *Applied Energy*;2017:208-17.
- [35] Pang-Chia Chen. Multi-objective control of nonlinear boiler-turbine dynamics with actuator magnitude and rate constraints. *ISA Transactions* 2013;52:115-28
- [36] Rabindra Kumar Sahu, Sidhartha Panda, Narendra Kumar Yegireddy. A novel hybrid DEPS optimized fuzzy PI/PID controller for load frequency control of multi-area interconnected power systems. *Journal of Process Control* 2014;24:1596-1608.
- [37] Soheil Ghabraei, Hamed Moradi, Gholamreza Vossoughi. Multivariable robust adaptive sliding mode control of an industrial boiler-turbine in the presence of modeling imprecisions and external disturbances: A comparison with type-I servo controller. *ISA Transactions* 2015;58:398-408.
- [38] T. Yu, K.W. Chan, J.P. Tong, B. Zhou, D.H. Li. Coordinated robust nonlinear boiler-turbine-generator control systems via approximate dynamic feedback linearization. *Journal of Process Control* 2010;20:365-74.
- [39] Ghazal Ghayem, Hamid Khaloozadeh. Modelling and Control of a Single Shaft Heavy Duty Industrial Gas Turbine Based on Operational Data. *International Journal on Control Systems and Applications* 2014;1:10.
- [40] Ebrahim Najimi, Mohammad Hossein Ramezani. Robust control of speed and temperature in a power plant gas turbine. *ISA Transactions* 2012;51:304-08.



- [41] Sanjeev K Nayak, D N Gaonkar. Modeling and Performance Analysis of Microturbine Generation System in Grid Connected/Islanding Operation. *International Journal of Renewable Energy Research* 2012;2:750-57.
- [42] Xian Guo , He Guo. Simulation and Control Strategy of a Micro-Turbine Generation System for Grid Connected and Islanding Operations. *Energy Procedia* 2011;12:368-76.
- [43] Domachowski Z. Specificity of automatic control of microturbines (steam or gas -driven and expanders) in dispersed generation system of heat and electric power. *Polish Maritime Research*. 2009;Special issue S1:9-13.
- [44] Kosowski K, Włodarski W, Piwowarski M, Stepień R. Performance Characteristics of a Micro-Turbine. *Journal of Vibration Engineering and Technologies* 2014;2:341-50.
- [45] Wajs J, Mikielwicz D, Bajor M, Kneba Z. Experimental investigation of domestic micro-CHP based on the gas boiler fitted with ORC module. *Archives of thermodynamics* 2016;37:79-93.
- [46] Włodarski W. Experimental investigations and simulations of the micro-turbine unit with permanent magnet generator. *Energy* 2018;158:59-71.
- [47] Kosowski K, Piwowarski M, Stepień R, Włodarski W. Design and investigations of the ethanol microturbine. *Archives of Thermodynamics* 2018;39:41-54.
- [48] Lawrynczuk M. Nonlinear predictive control of a boiler-turbine unit: A state-space approach with successive on-line model linearisation and quadratic optimisation. *ISA Transactions* 2017;67:476-95.
- [49] Pang-Chia Chen, Jeff S. Shamma. Gain-scheduled 1-optimal control for boiler-turbine dynamics with actuator saturation. *Journal of Process Control* 2004;14:263–77.
- [50] Shizhong Yang, Chunjiang Qian, Haibo Du. A genuine nonlinear approach for controller design of a boiler–turbine system. *ISA Transactions* 2012;51:446-53.
- [51] Wen Tan, Fang Fang, Liang Tian, Caifen Fu, Jizhen Liu, “Linear control of a boiler–turbine unit: Analysis and design”, *ISA Transactions* 47 (2008) 189–197

- [52] Wisam Abed Kattea Al-Maliki, Falah Alobaid, Vitali Kez, Bernd Epple. Modelling and dynamic simulation of a parabolic trough power plant. *Journal of Process Control* 2016;39:123-38.
- [53] Yong Wan, Jun Zhao, Georgi M. Dimirovski. Nonlinear adaptive control for multi-machine power systems with boiler-turbine-generator unit. *International Transactions on Electrical Energy Systems* 2015;25:859–75.
- [54] Normazlina Mat Isa, Chee Wei Tan, A.H.M. Yatim. A comprehensive review of cogeneration system in a microgrid: A perspective from architecture and operating system. *Renewable and Sustainable Energy Reviews* 2018;81:2236-63.
- [55] Kicinski J. Cogeneration in Small Scale – High Speed Microturbines Dynamic Analysis. *Archives of Acoustics* 2010;35:175-82.
- [56] Wood G, Newborough M. Dynamic energy-consumption indicators for domestic appliances: environment, behaviour and design. *Energy and Buildings* 2003;35:821-41.
- [57] Ahmed T. Elsayeda, Ahmed A. Mohamed, Osama A. Mohammed. DC microgrids and distribution systems: An overview. *Electric Power Systems Research* 2015;119:407-17.
- [58] Kosowski K, Piwowarski M, Stepień R, Włodarski W. Design and Investigations of a Micro-turbine Flow Part. *ASME Turbo Expo* 2012;5:807-14.
- [59] Kosowski K, Stepień R, Włodarski W, Piwowarski M, Hirt L. Partial Admission Stages of High Efficiency for a Microturbine. *Journal of Vibration Engineering and Technologies* 2014;2:441-48.
- [60] Jianhua Zhang, Wenfang Zhang, Guolian Hou, Fang Fang. Dynamic modeling and multivariable control of organic Rankine cycles in waste heat utilizing processes. *Computers and Mathematics with Applications* 2012;64:908-21.
- [61] Guolian Hou, Shanshan Bi, Mingming Lin, Jianhua Zhang, Jinliang Xu. Minimum variance control of organic Rankine cycle based waste heat recovery. *Energy Conversion and Management* 2014;86:576-86.



- [62] Thiago Antonio Melo Euzebio, Pericles Rezende Barros. Optimal Integral Gain for Smooth PI Control. IFAC Proceedings Volumes 2013;46(11):529-33.
- [63] Norman S. Nise. Control Systems Engineering. John Wiley & Sons, Inc. 2000.