

# Design and Evaluation of the Platform for Weight-Shifting Exercises with Compensatory Forces Monitoring.

Wiktor Sieklicki<sup>1</sup>[0000-0002-5713-7265], Robert Barański<sup>2</sup>[0000-0002-2728-6657], Szymon Grocholski<sup>1</sup>, Patrycja Matejek<sup>1</sup>, and Mateusz Dyrda<sup>1</sup>

<sup>1</sup> Gdańsk University of Technology, Gdańsk, Poland

<sup>2</sup> AGH University of Science and Technology, Kraków, Poland  
wiktor.sieklicki@pg.edu.pl, robertb@agh.edu.pl

**Abstract.** Details of a platform for the rehabilitation of people with severe balance impairment are discussed in the paper. Based upon a commercially available static parapodium, modified to fit force sensors, this device is designed to give a new, safe tool to physiotherapists. It is designed for the patients who cannot maintain equilibrium during a bipedal stance and need to hold to or lean on something during the rehabilitation. Visual, real-time information about weight distribution between left and right leg as well as the information about the force applied to the pillows supporting the patient's body is provided to the patient with help of a LED display. The control system allows registering forces applied by the patient to the device and analyze them after the therapy. The results of a preliminary evaluation of the device are presented in the paper with four healthy and one Cerebral Palsy ataxic participants. Two exercise scenarios are tested showing significant dependence between balance impairment and compensatory forces measured by the device, as well as a notable difference in how the subject strives for better results if the visual feedback is provided.

**Keywords:** Robotic Rehabilitation, Balance Training, Visual Biofeedback, Biomedical Electronics, Balance Impairment.

## 1 Introduction

Free body movements, walking and finally, locomotion gives the feeling of independence and personal safety. Diminished ability to achieve or maintain standing posture has a direct impact on general Activities of Daily Living (ADL) [1, 2] and increase the risk of falling [3–6]. It has also significant developmental and sociological consequences to an impaired person as well as to the family [1, 7, 8].

Cooperation of nervous, muscular, skeletal and fascia systems together with developed integrity of reactions, reflexes, tonus, acquired sensory system information as well as the intellectual, emotional and social capacity, determines the ability to execute free body movements and maintain equilibrium [9, 10]. Impaired balance is thus common among patients with neurological damage like Cerebrovascular Accidents (stroke) [8,

11–13], Traumatic Brain Injuries (TBI) [14], Spinal Cord Injuries (SCI) [15], Cerebral Palsy (CP) [7, 8], Parkinson's Disease (PD) [4, 16] and Multiple Sclerosis (MS) [3].

In many cases, the necessity to use rehabilitation aids emerge. Moreover, assistance from a third-person often becomes inevitable when dealing with everyday tasks as well as during the therapy sessions. Physical therapists working with balance impaired individuals have a highly demanding job being physically involved in exercises. Their goal is usually, to assist the patient in achieving a vertical position. This necessity comes from many advantages of keeping the upright body position [17, 18]. Training sessions can include extensive physical exercises during which a patient may burden their weight onto an assisting person at any moment. The intensity and duration of training sessions, therefore, have to consider the physical strength and endurance of a therapist. This limitation applies to any person assisting the patient. During everyday tasks, those are often parents, who are not necessarily trained nor physically prepared to bear the weight of their child as it gets older. As a result, people with severe balance deficits often end up in a wheelchair. The willingness to exercise in the standing position thus may fade as the main short term goal of locomotion is achieved. Ultimately, almost 40% of the untreated Dystonia patients and 24% of the injured spinal cord patients use a wheelchair [8]. In the case of Cerebral Palsy, it is reported that 29% and 41% of patients use a wheelchair indoors and outdoors respectively [19]. As much as 90% of patients using a wheelchair are classified at level IV-V of the Gross Motor Function Classification System (GMFCS) [19, 20].

Verticalization exercises are beneficial if a standing posture is maintained for 30 minutes to 4 hours a day [17, 21]. Martinsson and Himmelmann ([22]) reported positive physical outcomes when patients maintained the standing posture for 60 up to 90 minutes a day. They also found no positive effects of staying in a vertical position for less than 30 minutes a day. In another study, standing for not less than 7.5 hours a week was beneficial for the patients' health [14].

For a mildly affected patient this amount of time is achievable, but to lessen the boredom of repetitive, long-lasting exercises numerous rehabilitation aids targeting balance disorders have been developed. Interactive devices challenge patients with various means and are meant to diversify training sessions [23–25]. Often force platforms are introduced to make rehabilitation exercises more attractive to patients, thus maximize the time spent in training sessions [26, 27]. Recently a Nintendo Wii Fit has been widely offered as a low budget, weight-bearing assessment and exercise tool [28]. It provides a balance performance monitoring with visual and auditory feedback. Low cost and high availability of the platform makes it an interesting choice for therapists but some studies show, that not all patients can profit from this system [29, 30].

The free-standing exercises are not suitable if the patient is reluctant to an activity that exerts a risk of falling or an injury. Patients with severe balance disorders (GMFCS III-IV) and those who cannot keep an erect posture at all (GMFCS V) may need constant support of their trunk. For those patients, weight-relieving or side-supporting frames and harness-like systems (parapodium, walkers) are available. Parapodium is usually a modular frame with a wide base. Its function is to support a patient in an upright position by various elements of the device. The parapodia can be of two kinds: static parapodium, which stabilizes the body of the patient in an upright position, and

can provide support in the chest, hip, lumbar and knee areas, or a dynamic parapodium, which stabilizes a patient's body while allowing one to move around. This device is not suitable for gait training though, because the movement of the device is achieved through a side to side rocking movement, which does correspond to a correct walking pattern. Active forms of work with a patient held upright in a parapodium usually focus on activating patients' manual and cognitive skills. It is possible because a parapodium allows the patient to free their arms from supporting the body, while in most cases, simultaneously blocking their legs. A similar device is a walker. The patient strapped into the walker may move around on his feet being held upright. Unfortunately, there are no strong arguments to back the thesis, that exercising with the use of walkers allows to minimize coordination dysfunction, which in turn would allow the patient to be able to retain their balance without the help of assisting devices [31, 32].

The fact, that losing equilibrium may happen at any moment during training sessions or any other activity often narrows the rehabilitation to passively standing in parapodium. Quickly it becomes boring and annoying, especially if the patient has to keep the stance every day for over 30minutes. There are only a few rehabilitation tools for stability assessment and enhancement available for the patients who need assisting devices to maintain an upright position.

An example of a commercially available device answering this need is a static-dynamic parapodium BalanceReTrainer [13]. It keeps the patient in an upright position while allowing them for an inclination in coronal and sagittal planes for up to 10 degrees. Passive springs act against the frame's inclination. The feet of the patient remain attached to the floor. The device uses visual feedback that shows the patient the current inclination of their upper body. Measurements of the inclination are registered via accelerometers. The patient is requested to control the inclination of the body and follow instructions shown on a screen in front of him. The assessment of the patient's stability is based upon the concordance of the directions and amounts of inclination requested by the program and executed by the patient. Michalska and colleagues reported that training with BalanceReTrainer showed some improvements in weight-bearing abilities in CP patients, although mainly for patients classified at the level I and II of the GMFCS [33]. The limitation of this device is that the patient's Centre of Pressure (CoP) is significantly affected by a possible leaning on the device. Identification of the CoP during an unperturbed stance has become a well-established static posturography technique for the standing balance assessment. Displacement of the CoP is considered a representation of the equilibrium control to keep the Center of the body Mass (CoM) within the area of support [34]. In the case where the base of support is not only the two platforms beneath the patient, but also side pillows or additional handles, balance control extends beyond ankle/hip strategies ([35]) and the CoM displacement cannot be interpreted as CoP displacements acquired by force platforms only. There is no information gathered about the pressure applied by the patient to various parts of the Balance ReTrainer. Therefore, the device does not allow to properly assess the patient's CoP. Moreover, because the spring mechanism is the resistor for patient movements, the force required to perform an inclination rises, as the inclination gets greater.

Another device developed to facilitate therapy of balance impaired individuals, providing firm support to the patient's body is KineAssist [1]. Initially designed as a

portable system providing the patient with the possibility to walk while actively supporting their trunk in a vertical position. The device is also actively following the patient's steps, which makes KineAssist a more robust walker with wider functionality. There is no information about the patient's CoP position and displacement though. KineAssist recently changed the design and it became a stationary system with a treadmill beneath it. This made the device potentially suitable for exercises in stance and stability assessment.

Lokomat [36, 37] is probably the most commercially successful device designed for balance impaired individuals. In basic form it has 4 Degrees of Freedom (DoF) - left and right knee and hip joints. This way it can assist and guide the hip and the knee movements while the ankle joint is moved passively with a spring system. The patient is held upright by the set of suspenders. Additional feature includes a waist connection providing hips side movements and prevents backward movement. Lokomat is a gait training device though, and balance exercises in static stance cannot be executed nor it can help in the assessment of stability.

All of the mentioned devices are commercially available. KineAssist being a HDT Global product is sold by Woodway, Inc. Balance ReTrainer, under the name Thera-Trainer Balo, is a product of Thera Trainer. Lokomat is a product of Hocoma. One of the major drawbacks of mentioned rehabilitation robots is their cost ranging from \$6.500 (Thera-Trainer Balo), \$140.000 (KineAssist), up to \$330.000 (Lokomat).

Measurements of the weight distribution between left and right leg, together with the visual feedback, can be successfully done with the use of force platforms as it was proposed by various authors [10, 28]. It is a cheap and widely available solution. This device though is not suitable for people compelled to use a parapodium in order to maintain a standing position. If force platforms were to be used together with a parapodium, patients could act upon the supports exerting compensatory forces. This could lead to the consolidation of improper muscle tonus in bipedal stance, making patients even less able to maintain a standing position without being supported by the parapodium. The compensatory forces applied to the parapodium, necessary to compensate disturbances of stability, influence pressure distribution on the patients' base of support. Proper assessment of stability based on CoP displacement analysis in such setup is thus difficult and does not provide correct results [38]. The visual systems designed to assess the stability neither can be used in such case, because there is no information about direction/amount of compensatory forces exerted by the patient to the parapodium.

Those observations led the authors to develop JStep. A suitable device for patients, who are not able to maintain an upright position without the aid of a physiotherapist and orthopedic aids. It is designed for training and assessment of the weight-shifting asymmetry as well as compensatory strategies of balance impaired individuals within a fall-safe environment. JStep was initially described in [39], where authors briefly described its features and construction. A single case of use was there presented. The purpose of this study is to provide the proper background information and precise design criteria for this rehabilitation device, complete calibration procedures, as well as the mechanical and electrical features not described in the previous paper. This includes the compensatory forces identification and analysis. Moreover, in this study authors

wish to present results of testing the device with five healthy and one CP patients with the aim to indicate balance-shifting variations and accompanying compensatory forces.

We focused on the condition affecting a particular patient, so the objective was to design a device that meets the requirements of an Ataxic Cerebral Palsy patient rehabilitation. In general, this covers requirements of the individuals classified at level I-IV of the GMFCS. Some dysfunctions are not framed by the GMFCS though. Eligibility criteria for the patients who can use the device, are listed: a) the individual has enough muscle strength to operate his limbs, trunk and head, b) individual has only mildly affected sight (LogMAR visual acuity  $\leq 0.45$ , Snellen:  $\leq 20/56$  or  $\leq 6/17$ , decimal  $\leq 0.35$ ) [40, 41], c) individual is communicative and understands verbal commands.

Criteria for the development of the device are presented in Section 2 of this paper; the device structure, sensory system, visual feedback are described in Section 3; in Section 4 the evaluation of the device, participants description, exercises' scenarios and tests results are presented; conclusions and discussion are presented in Section 5.

## 2 Design Criteria

A compulsory feature of a rehabilitation system targeting balance impairment of patients classified at level IV-V of the GMFCS would be a fall-safe environment. Lifting the threat of falling should give patients the possibility to comply more closely with the exercise protocol [42, 43]. This is particularly difficult for the device which purpose is to exercise balance [4]. It requires that the device is either following movements of the patient (e.g., powered walker, exoskeleton), or allows him to move within (e.g., parapodium, harness-like support system) with a possibility to hold/lean on.

An important aspect of the rehabilitation is that it refers to an impaired person who needs a therapy, not just the impairments that are to be cured. Physiotherapists' task is therefore not only to administer the physical exercises but also to find the most attractive way to work with the specific patient [44]. On the other hand, repetition strategy is considered strongly influential for maintaining brain changes acquired during the rehabilitation [45]. This requires consistent practice with repetitive movements. It is not necessarily interesting nor meaningful for the patient though, what in turn may reduce their willingness to participate in rehabilitation. Some patients may not recover or gain standard mobility at all. Even though, for the sake of their health it is crucial to proceed with balance exercises and motivate them to keep the bipedal stance during the day [17, 18]. The Rehabilitation device should therefore provide possibilities to engage patients more in exercises and give them enjoyable, task-based training protocol [13, 46].

Visual feedback may encourage patients to persist in their efforts and create positive reinforcement [29, 47]. To achieve this, a close interaction between the subject's actual equilibrium management and the outcomes of a single task should be evident for the patient. Since cognitive and cognitive-motor based training are reported effective to improve standing balance [48] both actual weight-bearing as well as forces exerted onto the fall-preventing structure displayed in front of the patient could enhance this improvement. Minimizing the compensatory forces exerted onto the fall-preventing structure might become a new goal for the training. The capability of the on-demand weight-

shifting as well as the values of the compensatory forces during the task should be monitored to provide a track record of the patient's performance.

If keeping the balance during the rehabilitation is an issue, the therapeutic techniques presume that the patient may use their arms to hold to e.g., parallel bars, thus retain the equilibrium during exercises. Patients' stance model becomes quadrupedal this way, making it impossible to properly assess the CoP. To address this problem, the device should identify the forces transferred to the handles, harnesses, parallel bars or side pillows by the patient while one compensates for imbalance. As the result, an objective measure of compensation necessary to avoid losing the equilibrium could be: a) the amount of time the patient availed the support while executing a specific task [49], b) the amount and direction of force applied to the support while executing the task. An adequate method of visualization should be provided to properly inform the patient about actual readings of the system. The minimal distance between the patient and the visualization panel, with respect to the minimal dimension of letters/controls lights displayed on the visualization panel, is calculated for the visual acuity  $n=0.35$  (in Snellen decimal scale). The letters height  $h[m]$  is obtained from the visual angle formula (1), where  $\Theta$  (equals 5 minutes of arc for letters [50] and has to be converted to degrees),  $d[m]$  is the distance between the eye and the letter, and  $n$  is the Snellen visual acuity decimal representation. This means the visualization panel installed 2m away from the patient's head should have letters taller than 8.31mm. The control lights diameter should be greater than 1 minute arc what results in 1.6mm of diameter on a distance of 2m according to (1) if theta equals 1 minute of arc [50]. For the lights to be distinguishable, the distance between them should also be 1.6mm.

$$h=1/n \cdot 2 \cdot d \cdot \tan(\Theta/2) \quad (1)$$

The ability to shift the body weight onto a single leg plays a significant role in walking. Weight transfer between right and left legs should be considered one of the tasks practicable with the use of the rehabilitation device. Another widely accepted condition is for the subject to stand still in bipedal stance and to distribute weight equally on both legs. With this setup, a weight-bearing capacity assessment is usually linked [51, 52]. The rehabilitation device should, therefore, enable to assign both exercises scenarios [53, 54]. As reported by Goldie and coll. ([53]), the therapeutic approach should focus on improving weight-shifting to both legs, independently which is the affected one. The differences in the patient's capacity to transfer the correct amount of weight onto a selected leg can be considered a weight-shifting asymmetry[55]. The amount of time the demanded weight distribution should be maintained during tests is usually considered when functional balance tests are conducted [9]. Based on the testing procedures of weight-bearing capacity assessment, 5 seconds should be enough ([53]).

Since the interaction between the patient and the device is based upon the forces exerted to the device, the patient's performance can be considered a quantitative assessment of the balance. According to Mancini and Horak ([49]), automatic algorithms for quantifying balance control during prescribed tasks are necessary to make the quantitative measures of balance feasible for clinical practice. Moreover, they conclude that the user-friendly interfaces and convenient data storage as an electronic medical records are important.

### 3 JStep rehabilitation platform

The device is built on the foundation of a static, standing frame PJMS 180 (Figure 1, left). It is a commercially available parapodium. This ensures that the patient is safely held upright in the bipedal stance. The patient stands in the parapodium with his feet on two independently mounted platforms (Figure 1, right). The distance between the platforms is adjustable in the coronal plane. The patient is kept in the vertical, bipedal stance by a set of pillows on the sides, as well as on the front and in the rear of the parapodium. Adjustment of the pillows position can be done matching height of the hips of the patient and keeping desired distance between left and right pillows. The patient can lift his legs and bend the knees on demand. If the patient has little control over the extensor muscles of legs, a rubber-like horizontal bar on the height of the tibia may be installed limiting the forward movement of the knees. The device provides real-time visualization of the body weight distribution between the left and the right leg. Weight shifting is visualized on a panel installed in front of the patient (Figure 1, d). It also provides information about leaning of the patient on pillows of the parapodium.

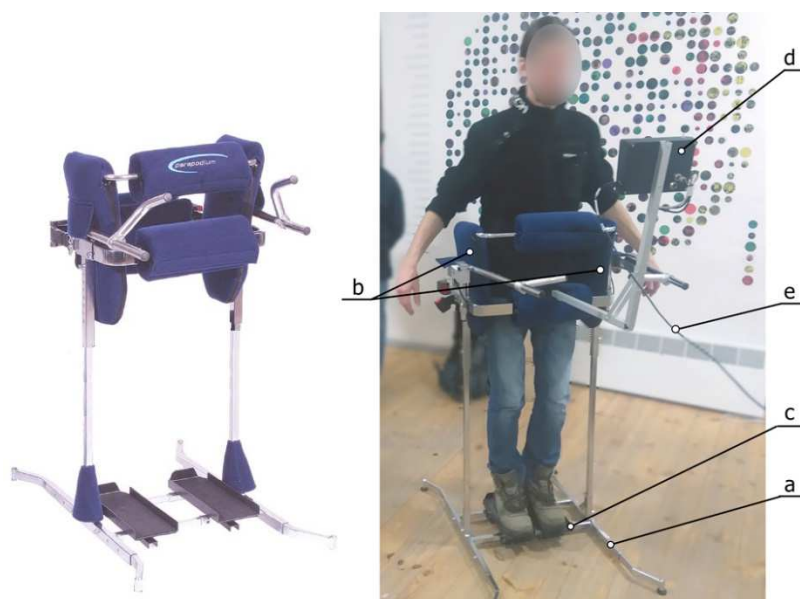

**Fig. 1.** Unmodified parapodium (left), and JStep during testing (right): a) mechanical structure, b) sensorized pillows, c) sensorized feet platforms, d) visualization panel, e) USB cable to PC.

#### 3.1 Sensory layer

Two sets of sensors are embedded in the structure. One set is implemented for measurements of weight applied to the platforms on which the patient stands. This solution assimilates JStep to a standard, static force platform. For this task, four YZC-161 load cells are placed beneath each platform. The advantage of those sensors is that they have

a very low profile (12mm) while being able to measure and withstand significant loads (up to 40kg each). Additionally, they are extremely cheap (\$10 for a pack of four sensors). The second set of sensors is responsible for the measurement of compensatory forces applied to the pillows. Those load cells are mounted in between the parapodium frame and the pillows. Each pillow is capable of sensing the force acting perpendicularly to its surface. Load cells used in the pillows are beam type load cells NA27-005, which are also quite inexpensive sensors costing approx. \$10 apiece.

Weight shifting from one leg to another implies movements of the hips to the sides. Preliminary tests showed, that approx. 3cm of space between the pillows and the patient's hips is enough to shift the body weight completely to one leg while keeping a vertical posture. Because the pillows provide a constant feeling of support to the patient though, this gap should be kept minimal. Based on the preliminary tests, a 90kg and 155-185cm tall individual leaning against the side pillow (the setup presented in Figure 2, left) produces max.  $F_{side}=41N$  of force. Similar results were obtained for the individual leaning against the rear pillow (the setup presented in Figure 2, right) with max. force  $F_{rear}=38N$  registered. Those values are dependent on how wide is previously discussed gap. The wider the gap is, the higher the forces applied to the pillows due to leaning are. The forces listed above are acquired for a 3cm gap between the patient's hips and the pillows on both sides. More details about the sensors' arrangement can be found in [39].

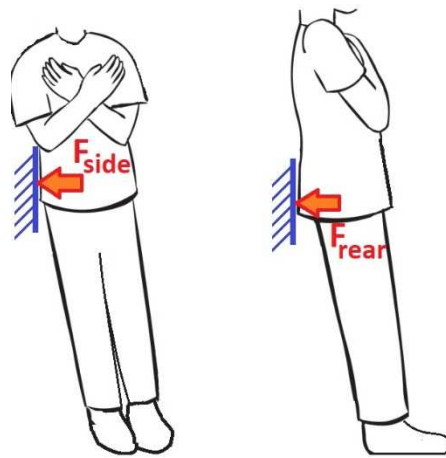

**Fig. 2.** Leaning against side (left) and rear (right) pillows model.

Verification of the stability and the reliability of both NA27-005 and YZC-161 was done after mounting them into the device. Sensors of this type have a close correlation between signal output level and the supply voltage. For example, the NA27 sensors, according to the technical specification, have a sensitivity of 1mV/V. In practice, this means that the sensitivity increases with the rise of the supplying voltage. In our design, a 5V supplying voltage was chosen. This is because the ATmega 328P, used as a central unit, powered from a 9V battery, provides enough power to obtain a stable 5V using the TL78L05 voltage stabilizer. The stability of the voltage supplying the sensor is of



utmost importance because any change (even momentary) in the input of the transducer instantly changes the sensitivity and thus, the level of the output signal.

The supply voltage stability tests were carried out with the assumption, that the expected time of a single training session with the use of the device shall be less than an hour. Various loads were applied to the sensor during the supply voltage stability test. The mean value of the supply voltage reached 5.02V with a standard deviation of 1mV (representing 0.2% of the supply voltage). The percent coefficient of variation of the supply voltage is calculated to be 0.002%. It is considered that such small changes in the supply voltage should not have a significant effect on the output signal.

An analog-to-digital converter (A/D) incorporated into the ATmeg328P system is a 10-bit converter operating in the standard voltage range of 0V to 5V. As a result, its quantization step is approx. 4.88mV. Since the expected voltage level measured directly from the force sensor is several to several dozen mV, the signal fed directly to the input of the A/D converter without any conditioning system would be burdened with a very large quantization error. For this reason, an implemented signal conditioning is composed of a low-pass filter, an amplifier and the A/D converter (Figure 3).

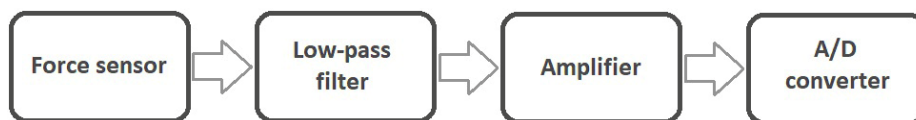

Fig. 3. Signal conditioning diagram

It is assumed that significant signal variations during the measurement will not take place more often than several times per second. Therefore, a passive filter with a cut-off frequency of 10Hz is used. The scheme of the filtration system is shown in Figure 4, left. To achieve the assumed cut-off frequency, parameters with values of  $R=166k\Omega$ , and  $C=1\mu F$  are chosen.

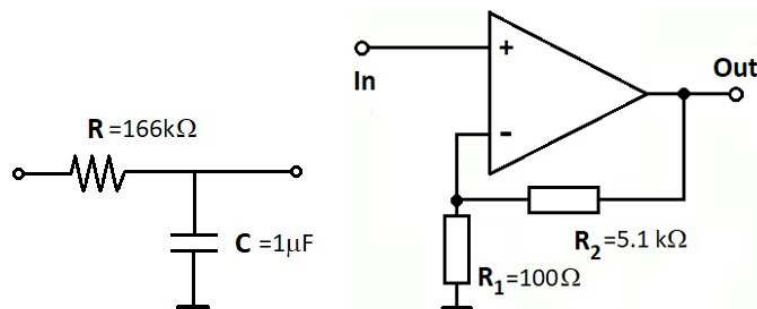

Fig. 4. Low-pass filter (left), and a general diagram of an operational amplifier in a non-inverting configuration (right).

An amplifier has a role of sensing the difference between the voltage signals that are applied to its inputs and multiply it by a gain  $A$ . For our application, a standard, inexpensive (less than \$1 apiece) operational amplifier TL084 is used in a non-inverting

configuration (Figure 4, right). The gain  $A$  is determined by an equation (2). The values of the  $R_1$  and  $R_2$  resistors are chosen to be  $R_1=100\Omega$  and  $R_2=5.1k\Omega$  giving a gain of  $A=52$ .

$$A = 1 + (R_2/R_1) \quad (2)$$

An important aspect of the strain gauge based force sensors is that the temperature variations may strongly influence the sensor's readouts. This effect can be minimized if the measurements are done in stable conditions (e.g. laboratory). However, independently from the environment influence, the excitation voltage increases the strain gauge's temperature creating a temperature drift.

To determine the characteristics of the NA27-005 temperature drift due to excitation voltage, a single sensor was tested in a room with a constant temperature of  $24^\circ\text{C} \pm 1^\circ\text{C}$ . Readouts were acquired from the moment the voltage was applied to the sensor till 60 minutes after. No mechanical load was applied to the sensor during the tests. The resulting characteristics conditioned with a low-pass filter and converted with use mentioned earlier A/D converter is presented in Figure 5.

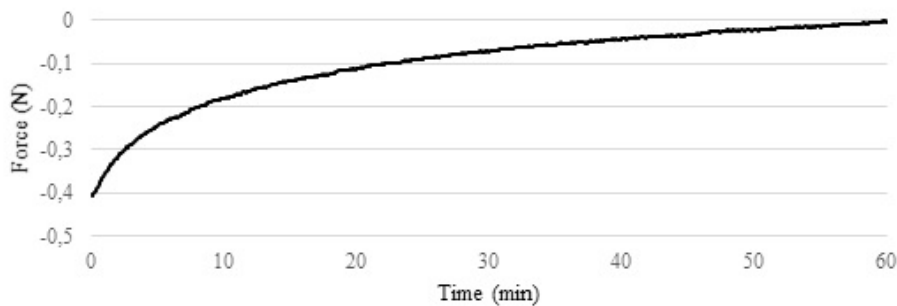

**Fig. 5.** NA27-005 force sensor temperature drift due to excitation voltage characteristics under the constant environment temperature conditions ( $24^\circ\text{C} \pm 1^\circ\text{C}$ ).

Tests revealed, that in a period of 60 minutes the readings increased of  $0.4\text{N}$ , which is approximately 1% of the measurement range ( $50\text{N}$ ). The change was most evident (50% of the total change) during the first 8 minutes of the test ( $0.2\text{N}$ ). Subsequent  $0.1\text{N}$  of the change was noticed after 21 minutes and finally after 60 minutes from the beginning of the test. The readings change rate can be defined as  $0.007\text{N}/\text{min}$  after 10 minutes from applying the excitation voltage. To solve this issue it is recommended to start the system 10 minutes before the measurements are taken. Another solution is to use larger gages and higher resistance gages. This would decrease the power necessary to be dissipated per unit area of a strain gauge.

The parameters of linear regression ( $ax + b$ ) determining the dependence of the load applied to the sensor and the sensor's output voltage were also calculated. For this reason, tests were carried out in a room with a constant temperature of  $24^\circ\text{C} \pm 1^\circ\text{C}$  within 3 days. 90 subsequent measurements with the use of 1, 2, and 3 kg load were done. The coefficients  $a$  and  $b$  were calculated and for all of the regression equations, the  $R^2$  was

not lower than 0.9999996, showing a linear relationship between the load and the output voltage signal.

All the above tests were carried out to check the reliability of signals from chosen force sensors. It should be noted that at the current stage of the project, the exact values of the force applied to the pillows are not of utmost importance. Rather the information about forces' variation is utilized in proposed training algorithms. Nevertheless, the knowledge about the sensors' stability rises the credibility of the system and opens up the possibility of using those sensors in the future if such functionality will be desired.

### 3.2 Visual feedback layer

Literature research [29, 47, 48], as well as the authors' observation of ataxic CP individuals, proved that the information about the weight-bearing and compensatory forces applied to the device has to be shown in a simple and informative way. Significant difficulties in reading and understanding complex information by patients with vestibular system damage do not allow the use of any numerical display with digits changing as, for example, patients shift their weight.

Our proposition for visual feedback is a Light Emitting Diode (LED) display incorporating five bars, each representing one sensing surface of the parapodium – left and right feet platform, left, right and back pillows ([39]). Each bar is composed of several LED lights placed in a row. Two yellow-red tapering bars in the center of the display are used for displaying the information about shifting the body weight between the left and right leg. When the force is equally distributed between left and right leg, yellow LEDs are illuminated (four of them on each side). Changing the body weight distribution to one of the legs results in illuminating more of the LED lights on this side. In other words, the more weight is on the side, the more LEDs are illuminated. Each LED corresponds to an amount of weight normalized as a percentage of body weight (%BW) shifted to the particular leg (Table 1). In this way, if the patient keeps the equilibrium or the weight-bearing is within a 56% threshold of the body weight, four yellow LEDs on both sides are illuminated. A shift of the body weight on an e.g. left leg so that 70% of body weight is kept on this leg results in six LEDs illuminated on the left bar. It does not necessarily mean though, that on the right bar there will be two LEDs illuminated. This number is influenced by the amount of force the patient exerts on the pillows of the parapodium to compensate for the loss of the equilibrium.

Leaning against the side pillows is represented by two LED bars placed on the sides of the display. Each bar is composed of 7 green LED lights placed in a row. Leaning against the back pillow is represented by a single LED bar on the bottom of the display. This bar is also composed of 7 green LED lights placed in a row. We noticed during the initial trials, that the patient was more enthusiastic and content with his actions when the successful movements resulted in as many illuminated LEDs as possible. Switching the LEDs off was associated for the patient with doing something wrong. Because of that switching-off, rather than illuminating LEDs was chosen as the measure of applied compensatory forces. When there are no forces applied to the pillows, all LEDs are thus illuminated. During the calibration process (discussed in subsequent Subsection) a maximum force ( $R_{\max}^n$ , where  $n=\{LP, RP, BP\}$ , which stands for Left Pillow, Right



Pillow and Back Pillow respectively) applicable by a patient to each pillow is registered. As soon as a force of more than 15% of  $R_{\max}^n$  is applied, a pair of utmost LED light on both ends of a corresponding LED bar is switched-off, resulting in 5 LEDs left illuminated. With a force of 30% of  $R_{\max}^n$  applied to a particular pillow, only three LEDs are left illuminated. Applying more than 40% of the  $R_{\max}^n$  force to a pillow results in only one LED left illuminated. This feature is organized differently to how the leaning on the device is managed in previous paper ([39]).

**Table 1.** The amount of LEDs illuminated for a respective load applied to a corresponding leg.

Amount of weight in % of total body weight (%BW) shifted to one leg	Amount of LED lights illuminated for a respective load
90-100%	8
79-89%	7
68-78%	6
57-67%	5
44-56%	4
32-43%	3
20-31%	2
9-19%	1
0-8%	0

Such a display arrangement allows understanding the body weight distribution at a glimpse of an eye. Therefore, it is easy to set a goal of the exercise as the patient can easily observe his weight shifts and possible leaning. It should also let the patient put more attention to execute the task, rather than focusing on reading the information from the display. The simplicity of the display is achieved at the expense of the resolution of the readings. Independent of what is shown to the patient on the LED display though, raw data is sent directly to the PC (Personal Computer) for further analysis.

The hardware layer of the LED display includes five SN74HC595 8-bit shift registers. This solution minimizes necessary analog outputs from a control unit to operate that many LED lights. Each LED bar is operated by one shift register. The operational frequency of the shift registries is approx. 25MHz. Considering a 16MHz clock frequency of the ATmega328P, the refresh rate of LEDs when all of the LEDs were illuminated was achieved approx. 15Hz. This is considered enough to interpret LEDs as constantly illuminated.

### 3.3 Sensors' calibration

The spasticity of some muscle groups in CP can cause the inability to equalize the body weight between the left and right leg. It does not, however, conclude for the inability of maintaining stability. The device allows calibrating the force range for each of the surfaces with force sensors so that it is tailored to the patient's capabilities and needs. Adjustment of the device performance to the patients of various weight is done thanks to the calibration of sensors.

The calibration is based on measuring the maximum force applied by the patient to the specific sensing surface and scaling the range of the readings accordingly. As discussed in the previous Subsection, maximum force applicable to the sensors is  $R_{\max}^n$ , where  $n=\{LP, RP, BP, LL, RL\}$  which stands for Left Pillow, Right Pillow, Back Pillow, Left Leg and Right Leg respectively. The result is, that the first LED and all LEDs up to the last one of a selected bar on the display are illuminated when minimum and maximum force is applied to a particular sensor respectively. The JStep functioning algorithm with a calibration loop is presented in Figure 6.

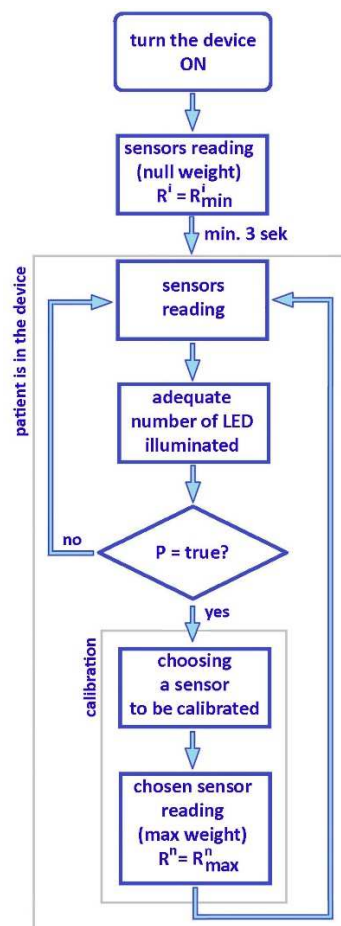

**Fig. 6.** An algorithm of the JStep functioning, with calibration loop included in which  $R$  represents current readouts,  $R_{\max}$  stands for maximum readouts obtainable for a particular sensor and  $n$  is a sensor index {left pillow, right pillow, back pillow, left leg or right leg}. "P" is an action of pressing the button on a top of the LED display box.

Each time the device is switched on, the first three seconds average reading is considered a null level for a sensor. During that time the patient cannot be in the device. The

system enters the operational mode after three seconds after which the patient may enter the device. As long as the button “P” on a top of the LED display box is not pressed, the device shows current sensors' readings in a form of the illuminated LED bars. It also sends numerical data to the computer. If the button "P" is pressed, the device enters calibration mode and one single light of a LED bar corresponding to the left foot platform starts flashing. Each push of the button "P" shifts the illuminated LED to a subsequent LED bar representing the left leg platform, right leg platform, left pillow, right pillow, and rear pillow. After five seconds, while the LED of the desired sensor is flashing, it enters a state in which readings from this sensor are being gathered for two seconds. At this point, the patient is asked to apply as much force to this sensing surface as he is capable. The system picks maximum value read ( $R_n$ ) during that time and sets it as the maximum value readable for this sensor ( $R_{max}^n$ ). This information is mapped to eight levels (in case of leg platforms) so that the LED bar can be lit properly. Afterward, the system goes back to operational mode and to calibrate another sensor, this procedure has to be repeated.

The presented procedure does not influence readouts sent to PC via USB. The user cannot change the raw data values sent to the PC during the process. The calibration refers only to the LED display resolution and range.

## 4 Evaluation

### 4.1 Participants

Three healthy males (age:  $25.7 \pm 3.2$  yrs, height:  $169.2 \pm 12.8$  cm, body mass:  $66.9 \pm 8.5$  kg), one healthy female (age: 32 yrs, height: 166 cm, body mass: 58 kg), and one Cerebral Palsy in the cerebellum male (age: 18 yrs, height: 175 cm, body mass: 61 kg) volunteered for the evaluation study.

The CP participant is classified with GMFCS level IV. His motor abilities allow him to sit and keep the torso upright while sitting. He's also capable of keeping his head upright and execute reaching tasks although dysmetria, tremor, and dyssynergia are evident. He has strong astigmatism and difficulties in controlling eye movements when tired. The subject moves around his home on all fours. He is unable to keep the bipedal stance without any support but he is capable of rising to the stance and keeping the upright standing posture if allowed to hold to stable support (e.g. furniture). Making the steps is challenging for the subject even with the use of external support. An assistant is necessary to walk him around the house but then the patient leans on the assistant giving him full control over the equilibrium. Due to the legs' spasticity, plantar flexion is present permanently. The subject struggles to maintain an upright standing position because he has to flex the knees, keep his weight on the toes and rotate his hips backward achieving anterior pelvic tilt. The result of such a posture is that the subject does not bring his hips into contact with the front pillow of a parapodium at all.

The one female participated in the study is a health professional who is knowledgeable about youth with CP and the GMFCS. All the participants provided informed consent prior to data collection.

## 4.2 Exercises scenarios

Most of the design criteria discussed in Section 2 are addressed through the sole concept of the device as a static frame, supporting the patient on-demand, as well as the sensory system with proper visualization of the forces the patient may exert to the supporting surfaces. A task-based approach with an embedded engagement mechanism needs more explanation though.

There are many exercise scenarios possible to realize with the use of a discussed device. In this paper, we would like to focus on exercises aiming to:

- increase the capability for on-demand weight-shifting and control over the amount of weight transferred onto a particular leg,
- decrease the amount of force exerted on the support surfaces, necessary to compensate for temporary loss of equilibrium while shifting the body weight.

The two objectives can be addressed with similar exercises scenarios. Given the possibilities provided by the LED display, two exercises are further described:

- Exercise 1: Illuminate a given amount of LED lights related to the body weight distribution.

The goal is to shift the body weight between the left and right leg to illuminate a given number of LEDs chosen from two tapering LED bars (described in Subsection 3.2). To complete the assignment, the given LED has to be kept illuminated for five consecutive seconds. Thus, the subject has to achieve and maintain a demanded weight distribution for 5 consecutive seconds. The subject has 120 seconds to succeed. Otherwise, the system automatically ends the assessment. In practice, one chosen LED light (from a set of 4 through 8) representing the left leg load is switched on at the LED display and starts blinking. It's a signal for the subject to shift his weight until this particular LED is illuminated and keep it illuminated for five consecutive seconds. The following round is similar but this time another light (from a set of 4 through 8) representing second leg is blinking.

- Exercise 2: Illuminate a given amount of LED lights related to the body weight distribution while refraining from switching-off any LED lights related to the forces applied to the pillows.

Here, the subject has to execute the same algorithm as in the first exercise but this time leaning on the device results in switching-off the LED lights on the display. Applying too much force to the pillows makes it impossible to accomplish the task. In practice, the weight-shifting assignment is managed alike the first exercise, but the subject has to pay attention not to lean against the pillows. Applying the force to the pillows results in switching-off the green LED lights and as soon as there is only one green LED light left illuminated (at any of the green LED bars), the whole task is suspended. Up until the subject stops leaning on the device, LED bars related to the body weight distribution are switched off.



For the sake of completing this exercise, a feasible threshold of force applicable to the pillows has to be set, otherwise, an individual with stability deficits will not be able to finalize this task at all. After some trial tests, the threshold value was set to 40% of the maximum force applicable to this particular pillow by this particular patient, as discussed in Subsection 3.2. This is in line with a very important aspect of gamification, which is the win-loss ratio. To keep the patient actively involved in the game, hence in the rehabilitation process, a game designer has to maintain the game challenging for the patient but at the same time plausible to succeed.

An algorithm responsible for selecting a task (LED light number) for consecutive rounds in both of the exercises is alike. To provide an equal distribution of tasks, each subsequent assignment is different from the previous one for this particular leg. Such a feature has been achieved by removing a LED light number that was chosen the last round from a set of LED lights numbers that are considered for the current round.

The subjects were asked not to grasp the parapodium frame with their hands. To facilitate that, they were given two small cylindrical objects to hold with their hands.

For the evaluation purposes, the device was located in a room with a constant temperature of  $24^{\circ}\text{C} \pm 1^{\circ}\text{C}$ . Tests were carried out during day time, assuring a similar light intensity in the room between the subsequent trials and for all the subjects.

Each healthy subject performed both the exercises scenarios for about half an hour resulting in approx. 70 assignments. Assessment of their capabilities is done based on those assignments and is further discussed in Subsection 4.3. In the case of the CP subject, the device was provided solely for him for the duration of six weeks. During this time the subject was asked to work with the assignments and complete each of them twice, every day. If the subject was sick or unable to perform his duty that day he was asked to complete his task the other day additionally to the scheduled exercises for that day. He was also asked to carry out the calibration procedure for the null weight and maximum weight for all the sensors each day before he did the assignments.

### 4.3 Data aggregation

All the results gathered include: date and time; current number of exercise (1 or 2); current round number  $r$ , where  $r=\{1,..10\}$ ; LED number  $k$  selected as a target for the exercise, which refers to the requested body weight distribution ( $k=\{4,5,6,7,8\}$ ); amount of time spent on completing the exercise ( $T_a$ ); amount of time spent with a correct body weight distribution ( $T_s$ ); and for the second exercise, the amount of time the patient applied the force to the pillows higher than a threshold ( $T_p$ ).

After each round the system sends an update to the PC with new information about the current training. At this stage of the project saving the results for each participant is done manually. This refers also to post-processing of the data, which is currently done in MS Excel 2010 environment. A script written in the Visual Basic is run for each spreadsheet with collected data. Following steps in order to obtain results are: removing null results, aggregation of the results for each exercise scenario, each task and each leg separately, building the charts and calculation of the linear regression function.





#### 4.4 Results

During six week time period the CP patient performed the first exercise scenario 154 times and the second exercise scenario 113 times. It took him 23 days to complete all these exercises.

The amount of time necessary for the patient to achieve and maintain the desired body weight distribution for five consecutive seconds ( $T_a$ ) is the first quality criteria. For the CP patient, the exemplary results of  $T_a$  gathered in a time span of 42 days while executing the exercise 1 are shown in Figure 7, left. Here the task was to keep the body weight evenly distributed between left and right leg with a maximum 56% of the weight on the one leg (fourth LED illuminated on the display for one leg). A trend function:  $y = -1.08t + 72$  with a coefficient of determination  $R^2 = 0.11$  are obtained. The plot shows very similar results to one presented as an example in [39] with some of the data points excluded though. This is because the normalization of the body weight is done with a different percentage levels used for illuminating particular LEDs what allowed to better distribute the body weight representation between consecutive LEDs.

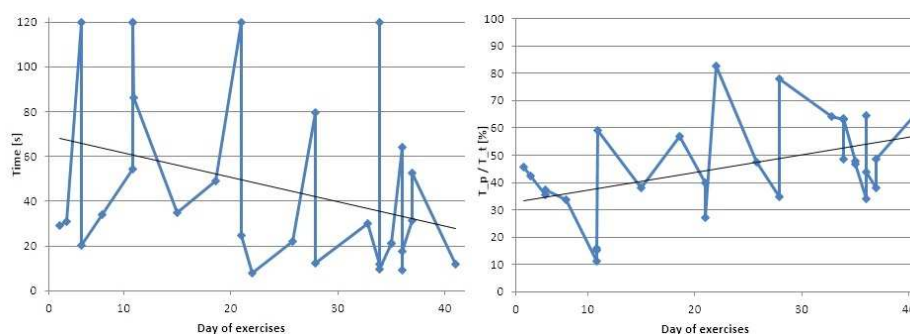

**Fig. 7.** Results obtained for CP participant: on the left - time necessary to complete the task in exercise 1 -  $T_a$ ; on the right - percentage of time necessary to complete the exercise during which patient achieved desired body weight distribution but not necessarily maintained it for consecutive 5 seconds -  $T_s\%$ . Data presented for case where the patient's weight had to be distributed evenly with up to 56% of weight on left leg.

The  $T_a$  linear trend function for all the body weight transfer cases, calculated for the six weeks training time of a CP patient is presented in Table 2. Presented in Figure 7, left case corresponds to the trend function listed in Table 2, third row, last column. Here, the activity which initially required approximately 70 seconds to complete (compound  $b$  of the  $y = ax + b$  function) after 6 weeks of training was more often achieved in only 25 seconds. A decrease in time necessary to succeed in exercise 1 as the training proceeded can be noticed for all the body weight transfer cases except 90-100% of the body weight transferred on one leg case. Here the time required to complete the exercise extended throughout the training period for both left and right leg. Based on a trend function, the time necessary to complete the exercise for both legs combined is presented also as a percentage value ( $\Delta T_a$ ) of the initial result. From those numbers it can be concluded, that the calculated time necessary to complete exercise 1 was decreased 63% in the case

where the task was to keep the equilibrium. Best results were obtained for the case where the task was to minimally (57-67% of the body weight) transfer the body weight to one leg. Here the improvement was calculated 88%.

**Table 2.** Linear trend function  $y=ax+b$  of  $T_a$  and  $T_{s\%}$  in function of days (t) the exercises were performed for subsequent body weight distribution cases. LL stands for the left leg, RL - right leg, and TO – combined results from both legs. Additionally,  $\Delta T_a$  is a percentage change of time necessary to complete the exercise for both legs combined based on a trend function  $T_a$  (TO).

	100-90% of body weight on one leg	89-79% of body weight on one leg	78-68% of body weight on one leg	67-77% of body weight on one leg	up to 56% of body weight on one leg
$T_a$ (LL)	$1.09t+36$	$-0.82t+86$	$-0.77t+58$	$-1.45t+65$	-
$T_a$ (RL)	$0.87t+84$	$-1.77t+110$	$-0.57t+58$	$-1.56t+76$	-
$T_a$ (TO)	$0.32t+74$	$-1.31t+100$	$-0.66t+59$	$-1.5t+71$	$-1.08t+72$
$T_{s\%}$ (LL)	$-0.63t+61$	$0.69t+25$	$0.3t+40$	$0.64t+33$	-
$T_{s\%}$ (RL)	$-0.28t+15$	$1.12t+8$	$0.6t+33$	$0.83t+28$	-
$T_{s\%}$ (TO)	$0.13t+25$	$1.01t+13$	$0.44t+37$	$0.75t+31$	$0.64t+30$
$\Delta T_a$ [%]	-16	53	46	88	63

To compare the results with healthy participants the exemplary results showing  $T_a$  calculated as a mean value of all the healthy participants is shown in Figure 8, left. The participants had to accomplish the task at least 12 times, not necessarily during an extended training period like in the case of CP patient. Here, in the case where the task was to keep the body weight evenly distributed with a maximum 56% of the body weight transferred on one leg, the calculated trend function is:  $y=0.02t+2$  with a coefficient of determination  $R^2=0.76$ .

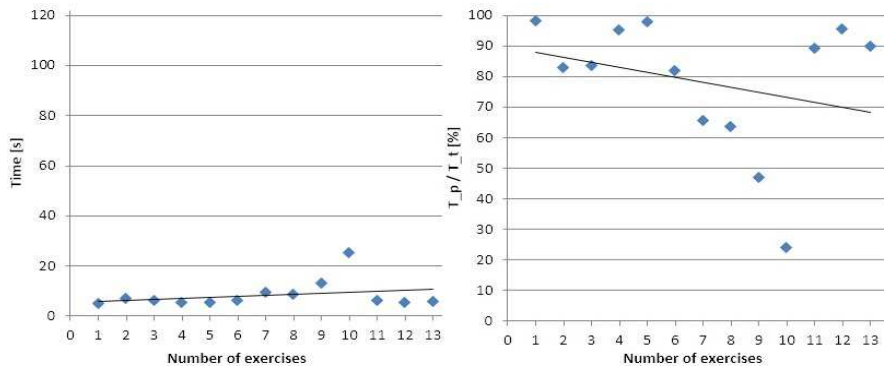

**Fig. 8.** Healthy participants' results: on the left – mean time required to complete the task in exercise 1 ( $T_a$ ); on the right - percentage of mean time necessary to complete the exercise during which patient achieved desired body weight distribution but not necessarily maintained it for consecutive 5 seconds ( $T_{s\%}$ ). Data presented for the case where the patients' weight had to be distributed evenly with up to 56% of weight on one leg.

Mean values of time ( $\overline{T}_a$ ) required to complete the task in exercise 1 together with standard deviation for both CP patient and healthy patients are presented in Table 3. For the CP patient the most time was required to complete the task of putting the whole body weight on one leg (80 seconds on average). This result was mainly due to high results for loading the right leg (97 seconds on average). The tendency was maintained as for the time required to complete the task in case of transferring the body weight to the left and right leg across all the load cases. This result clearly shows the weight-shifting asymmetry in CP patient's behavior. Healthy patients did not show such a tendency. Moreover, much lower standard deviations were calculated for the healthy patients suggesting that this might be a proper indicator of the balance impairments.

**Table 3.** Data referring mean time  $\overline{T}_a$  necessary to complete the task in exercise 1 calculated as combined results from both legs (total) as well as for the left and right leg separately in all five body weight distribution cases. LL stands for the left leg and RL stands for the right leg.

	Percentage of body weight on one leg:	100-90%	89-79%	78-68%	67-57%	up to 56%
CP patient (mean)	$\overline{T}_a$ total [s]	80, SD=46	73, SD=40	45, SD=30	37, SD=34	47, SD=39
	$\overline{T}_a$ (LL) [s]	60, SD=51	67, SD=43	43, SD=28	33, SD=30	-
	$\overline{T}_a$ (RL) [s]	97, SD=35	79, SD=39	46, SD=33	41, SD=37	-
healthy patients (mean)	$\overline{T}_a$ total [s]	16, SD=10	12, SD=2	16, SD=7	14, SD=2	12, SD=2
	$\overline{T}_a$ (LL) [s]	13, SD=3	13, SD=4	22, SD=13	15, SD=9	-
	$\overline{T}_a$ (RL) [s]	14, SD=3	15, SD=3	11, SD=2	12, SD=1	-

The second quality criterion for both of the exercises is  $T_s\%$  which is the amount of time during which the desired body weight distribution was achieved but not necessarily maintained for consecutive five seconds. The  $T_s$  in its nominal value is highly dependent upon the overall time of completing the task. It has to be therefore further discussed as:

$$T_s\% = T_s/T_a \cdot 100\% \quad (3)$$

The exemplary results for  $T_s\%$  are presented in Figure 7, right. In this case, the task was to distribute the body weight evenly between left and right leg with a maximum 56% of the body weight on one leg. Exercises were done in a timespan of 42 days. A complete list of  $T_s\%$  results obtained for the CP patient is presented in 4<sup>th</sup> to 6<sup>th</sup> row of Table 2. For the case where the task was to distribute the body weight evenly between left and right leg the  $T_s\%$  trend function  $y=0.64t+30$  with a coefficient of determination  $R^2=0.2$  was obtained. Similarly to the  $T_a$  results,  $T_s\%$  show improvement across all the cases but one - 100-90% of the body weight transferred to one leg. Although it is not completely true, because even though the result obtained for the left leg show worsening ( $a$  compound of the  $y=ax+b$  function is -0.63),  $b$  compound is very high (=61) showing high success ratio from the beginning. Again, worst results are thus for the right leg with trend function calculated to be  $y=-0.28t+15$ . In all load cases, the  $b$  compound of the trend function for the right leg was the lowest. Mean results for healthy participants are presented for comparison in Figure 8, right, showing significant spread.

A dataset from Table 3 referring mean time  $\overline{T}_a$  for CP patient is presented in Figure 9. It provides a quick information about posture dissymmetry. It is instantly notable, that tasks involving shifting body weight to the right leg require more time to accomplish. It may be assumed, that those tasks are more difficult for the patient to execute. Also, the more weight is to be transferred to the right leg, the more difficult the task becomes. In the task of transferring body weight onto the left leg, the patient did not succeed only twice (for 87 times the task was assigned) whereas in the case of transferring body weight onto the right leg it happened 11 times throughout all 67 times the task was assigned. This also indicates problems with the weight-shifting abilities.

Personal observations of the patient, while he was in training, revealed that most of the time he did not succeed happened when he was distracted by a nearby discussion or was anxious to do something else in the time he was exercising. It is disputable therefore if a drop-out ratio should be considered as an important parameter for determining weight-shifting abilities.

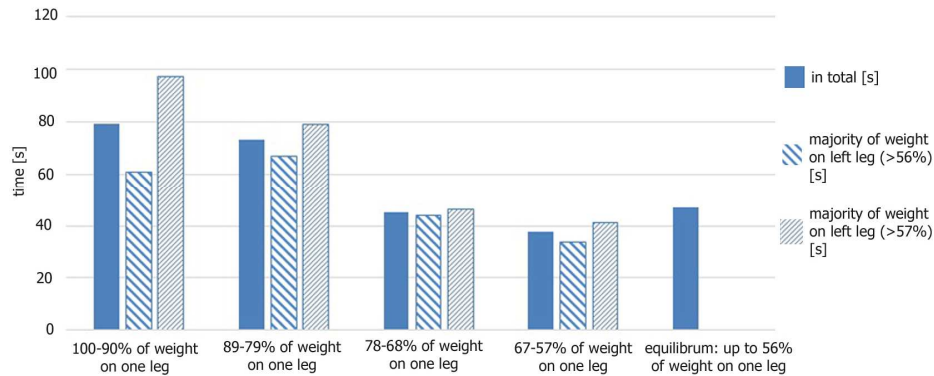

**Fig. 9.** Mean time value  $\overline{T}_a$  necessary to complete a task in exercise 1 for CP subject- data divided for five levels of body weight distribution and presented for each leg separately as well as for both legs combined (total)

Results referring second goal of exercises, that is to estimate and possibly decrease the amount of force exerted on the support surfaces (necessary to compensate for a temporary loss of equilibrium while shifting the body weight) are shown in Figure 10, left. Those results are obtained for a CP subject, whereas the mean results for the healthy participants are shown in Figure 10, right. The CP subject tends to lean on the parapodium especially when the information about applied force was not provided to the patient at the time. The best results for this scenario subject achieved for the case, where the task was to shift the body weight of 68-78% to the left leg. The patient leaned on the parapodium for half the time required to succeed in the task ( $T_p=50\%$ ). Most leaning occurred when the task was to transfer more than 79% of the body weight to one of the legs ( $T_p\cong 80\%$ ). Mean value across all the cases for the CP patient was calculated to be  $\overline{T}_p=69\%$ .

When the information about the force was displayed to the subject (exercise 2), he achieved best results for the left leg ( $T_p=16\%$  for the 79-89% loading case) and the

mean  $\overline{T_p}$  time was calculated to be 30% of the task realization time, what is a far better result than in exercise 1.

For comparison of results between CP and healthy subjects, the mean  $\overline{T_p}$  time for all the healthy subjects is presented in Figure 10, right. It is evident, that healthy subjects did not need support in order to finish the task. The worst results here were obtained for the 90-100% task scoring  $T_p=12\%$ . This may suggest, that 3cm of clearance between hips and pillows might not be enough for shifting the weight without touching the pillows.

Restriction inflicted in the second exercise by the presence of side and rear pillows extended the time necessary for the CP patient to achieve and maintain the desired body weight distribution for five consecutive seconds ( $T_a$ ). Mean value  $\overline{T_a}$  was calculated for 100-90%, 89-79%, 78-68%, 67-57% and for the equilibrium with up to 56% of the weight on one leg cases to be 61, 75, 62, 81 and 71 seconds respectively. Here the differences in shifting body weight over left or right leg are not so obvious:  $\overline{T_a}$  (LL): 20, 81, 56, 99 seconds, whereas  $\overline{T_a}$  (RL): 82, 58, 73, and 64 seconds for each mentioned above weight cases.

The task of transferring the body weight properly to the left and right leg in the second exercise was assigned 57 and 56 times respectively. In the case of the left leg, the patient did not manage to achieve success in the 120 seconds time limit six times and for the right leg, it was eight times. This resulted in standard deviations of  $T_a$  SD=38 for the left leg and SD=66 for the right leg results. Again, the drop-out cases were mostly inflicted by external disturbances.

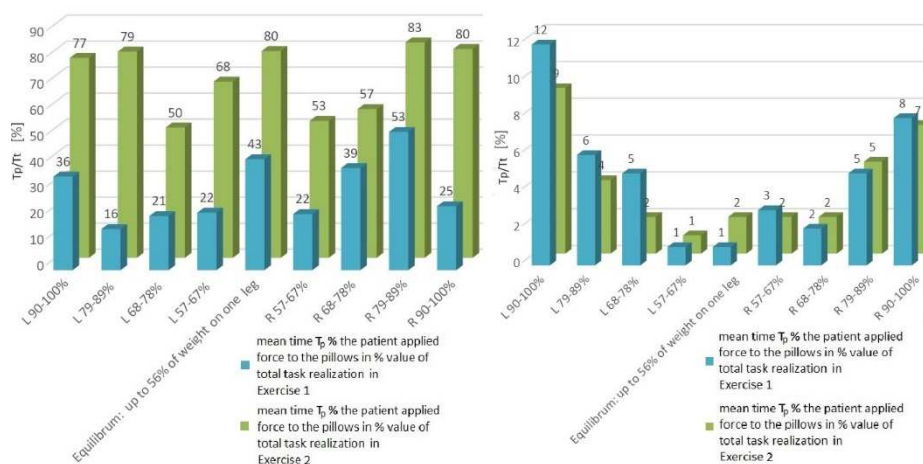

**Fig. 10.** Mean time value  $\overline{T_p}$  the force was applied to the pillows during the realization of the task. Results presented for exercise 1 and exercise 2: results obtained for a CP subject (left), and results obtained for healthy participants (right).

The results in the case of the second exercise are much more consistent and show very similar  $T_a$  values for all four cases where the weight had to be shifted onto the left leg.

We noticed very little improvement of  $T_a$  and  $T_s\%$  parameters over the six-weeks training time in case of the second exercise. This is probably due to a very high difficulty the patient had with completing the task of shifting the body weight while simultaneously caring not to lean on the device.

## 5 Conclusions and discussion

In the paper, authors have presented a device for training and assessment of the weight-shifting asymmetry and compensatory forces monitoring within a fall-safe environment. The discussed assisting device is suitable for patients, who are not able to maintain an upright position without the aid of a physiotherapist and orthopedic aids. It enables training of weight-shifting in the coronal plane and provides visual feedback informing about the patient's current body weight distribution as well as the forces inflicted on the pillows while leaning on the device.

Our concept fits the needs of the individuals classified at level I-IV of the GMFCS and who has enough muscle strength to operate the limbs, trunk, and head. In order to utilize the visual feedback function, the patient may have only mildly affected sight, has to be communicative and understand verbal commands.

The body weight distribution, as well as the compensatory forces inflicted on the device, necessary to minimize the disturbances of stability, are presented in the form of illuminated LED lights at the front of the patient. Such functionality gives the patient and the physiotherapists real-time information about body weight distribution. Furthermore, it provides a wider knowledge about the compensation the patient may need to keep the upright standing position.

Two exercises are proposed to train stability with the use of the device. Both involve shifting the patient's body weight in the coronal plane so that it matches requested body weight distribution. The second though requires the patient to avoid leaning on the side and rear pillows of the parapodium. Performing proposed exercises allows for the estimation of the capabilities of the patient. As an outcome of executing the exercises, a set of parameters measured and calculated during the training session is achieved:

- the amount of time necessary for the patient to achieve and maintain the desired body weight distribution for five consecutive seconds ( $T_a$ ),
- the amount of time during which the desired body weight distribution was achieved but not necessarily maintained for consecutive five seconds ( $T_s$ ),
- the amount of time the patient leaned on the parapodium ( $T_p$ ).

The device was tested with four healthy and one ataxic Cerebral Palsy subjects. CP subject was training for 6 weeks period. During this time the patient performed 267 times the exercises described. It means the patient spent approximately 30 hours in the device safely standing and performing exercises, which is already a great success. Some of the results are already presented in [39], others include an analysis of forces applied to the side pillows for both the exercises and the comparison of the CP patients results to the healthy subjects' results. Moreover, current results had been normalized with different percentage levels of body weight used for illuminating particular LEDs, which

allowed to better distribute the body weight representation between the consecutive LEDs.

Very high readouts were collected for the  $T_p$  in case of a CP subject (leaning on the device for up to 83% of the time required to complete the exercise) in comparison to the healthy subjects (up to 12%). For this reason, the device might be considered suitable for an assessment of the compensatory forces applied to the parapodium. Moreover, a significant improvement in  $T_p$  was observed for the case when the currently inflicted compensatory forces were shown to the patient in respect to the case when this information was hidden. This was not observed in the case of healthy patients. Furthermore, high values of  $T_p$ , for exercise 1 in comparison to exercise 2 suggest, that informing the patient verbally, that he should not lean on the device does little in comparison to the patient's self-awareness if he is restricted from winning a game unless he does not stand correctly. This particular result is of great significance, because it suggests, that gamification has the ability to further increase patient's efforts in order to pursue rehabilitation goals. This may be achieved if the game mechanics is carefully adjusted to match the physical rehabilitation requirements.

Another indicator of the possible issues with maintaining the balance is that the mean time necessary to complete the task  $\bar{T}_a$ , while executing exercise 1, was lower ( $\bar{T}_a=57$  seconds) than in the case of executing exercise 2 ( $\bar{T}_a=67$  seconds). This means that the restriction inflicted in the second exercise by the presence of side and rear pillows does require from the patient more attention to the compensatory forces inflicted to the device. This result can be further exploit in order to create training scenarios for the weight-shifting asymmetry with necessary compensatory forces minimization.

Further works include the development of a more sophisticated environment, where the patient is motivated to pursue the best results based on the gratification system embedded in a computer game. Moreover, the game scenarios should include increasing difficulty of the tasks required from the patient. This includes an initial level of repetitive movements, intermediate level of some movements variability and finally an advanced level of random body weight distribution requests.

## References

1. Patton, J., Brown, D.A., Peshkin, M., Santos-Munné, J.J., Makhlin, A., Lewis, E., Colgate, E.J., Schwandt, D.: KineAssist: Design and Development of a Robotic Overground Gait and Balance Therapy Device. *Top. Stroke Rehabil.* 15, 131–139 (2008). doi:10.1310/tsr1502-131
2. Harun, A., Semenov, Y.R., Agrawal, Y.: Vestibular Function and Activities of Daily Living. *Gerontol. Geriatr. Med.* 1, 233372141560712 (2015). doi:10.1177/2333721415607124
3. Cattaneo, D., De Nuzzo, C., Fascia, T., Macalli, M., Pisoni, I., Cardini, R.: Risks of falls in subjects with multiple sclerosis. *Arch. Phys. Med. Rehabil.* 83, 864–867 (2002). doi:10.1053/apmr.2002.32825
4. Allen, N.E., Sherrington, C., Paul, S.S., Canning, C.G.: Balance and falls in Parkinson's disease: A meta-analysis of the effect of exercise and motor training. *Mov. Disord.* 26, 1605–1615 (2011). doi:10.1002/mds.23790
5. Geurts, A.C.H., de Haart, M., van Nes, I.J.W., Duysens, J.: A review of standing balance



- recovery from stroke. *Gait Posture*. 22, 267–281 (2005). doi:10.1016/j.gaitpost.2004.10.002
6. Horak, F.B.: Postural orientation and equilibrium: what do we need to know about neural control of balance to prevent falls? *Age Ageing*. 35 Suppl 2, ii7–ii11 (2006). doi:10.1093/ageing/af1077
  7. Batra, M., Sharma, V.P., Batra, V., Malik, G.K., Pandey, R.M.: Postural Reactions: An Elementary Unit for Development of Motor Control. *Disabil. CBR Incl. Dev.* 22, (2011). doi:10.5463/dcid.v22i2.30
  8. Bronstein, A.M.: *Clinical disorders of balance, posture and gait*. Arnold (2004)
  9. Horak, F.B.: Clinical assessment of balance disorders. *Gait Posture*. 6, 76–84 (1997). doi:10.1016/S0966-6362(97)00018-0
  10. Winter, D.A., Patla, A.E., Frank, J.S.: Assessment of balance control in humans. *Med. Prog. Technol.* 16, 31–51 (1990)
  11. Roerdink, M., Geurts, A.C.H., de Haart, M., Beek, P.J.: On the Relative Contribution of the Paretic Leg to the Control of Posture After Stroke. *Neurorehabil. Neural Repair*. 23, 267–274 (2009). doi:10.1177/1545968308323928
  12. Drużbicki, M., Przysada, G., Rykała, J., Podgórska, J., Guzik, A., Kołodziej, K.: Ocena przydatności wybranych skal i metod stosowanych w ocenie chodu i równowagi osób po udarze mózgu Evaluation of the effectiveness of selected scales and methods used in the assessment of gait and balance after a cerebral stroke. *Przegląd Med. Uniw. Rzesz.* 21–31 (2013). doi:10.15584/ejcem.
  13. Matjacić, Z., Hesse, S., Sinkjaer, T.: BalanceReTrainer: a new standing-balance training apparatus and methods applied to a chronic hemiparetic subject with a neglect syndrome. *NeuroRehabilitation*. 18, 251–9 (2003)
  14. Katz, D.I., White, D.K., Alexander, M.P., Klein, R.B.: Recovery of ambulation after traumatic brain injury. *Arch. Phys. Med. Rehabil.* 85, 865–869 (2004). doi:10.1016/j.apmr.2003.11.020
  15. Dietz, V., Fouad, K.: Restoration of sensorimotor functions after spinal cord injury. *Brain*. 137, 654–667 (2014). doi:10.1093/brain/awt262
  16. Ferrazzoli, D., Fasano, A., Maestri, R., Bera, R., Palamara, G., Ghilardi, M.F., Pezzoli, G., Frazzitta, G.: Balance Dysfunction in Parkinson's Disease: The Role of Posturography in Developing a Rehabilitation Program. *Parkinsons. Dis.* 2015, 1–10 (2015). doi:10.1155/2015/520128
  17. Walter, S.J., Sola, G.P., Sacks, J., Lucero, Y., Langbein, E., Weaver, F.: Indications for a Home Standing Program for Individuals with Spinal Cord Injury. *J. Spinal Cord Med.* 22, 152–158 (1999). doi:10.1080/10790268.1999.11719564
  18. Verschuren, O., Peterson, M.D., Balemans, A.C.J., Hurvitz, E.A.: Exercise and physical activity recommendations for people with cerebral palsy. *Dev. Med. Child Neurol.* 58, 798–808 (2016). doi:10.1111/dmcn.13053
  19. Rodby-Bousquet, E., Hägglund, G.: Use of manual and powered wheelchair in children with cerebral palsy: a cross-sectional study. *BMC Pediatr.* 10, 59 (2010). doi:10.1186/1471-2431-10-59
  20. Palisano, R.J., Rosenbaum, P., Bartlett, D., Livingston, M.H.: Content validity of the expanded and revised Gross Motor Function Classification System. *Dev. Med. Child Neurol.* 50, 744–750 (2008). doi:10.1111/j.1469-8749.2008.03089.x
  21. Tardieu, C., Huet de la Tour, E., Bret, M.D., Tardieu, G.: Muscle hypoextensibility in children with cerebral palsy: I. Clinical and experimental observations. *Arch. Phys. Med. Rehabil.* 63, 97–102 (1982)
  22. Martinsson, C., Himmelmann, K.: Effect of Weight-Bearing in Abduction and Extension on Hip Stability in Children With Cerebral Palsy. *Pediatr. Phys. Ther.* 23, 150–157 (2011). doi:10.1097/PEP.0b013e318218efc3
  23. Shumway-Cook, A., Hutchinson, S., Kartin, D., Price, R., Woollacott, M.: Effect of



- balance training on recovery of stability in children with cerebral palsy. *Dev. Med. Child Neurol.* 45, 591–602 (2003)
24. Shirota, C., van Asseldonk, E.H.F., Matjacić, Z., Vallery, H., Barralon, P., Maggioni, S., Buurke, J.H., Veneman, J.F.: Robot-supported assessment of balance in standing and walking. *J. Neuroeng. Rehabil.* 14, 80 (2017). doi:10.1186/s12984-017-0273-7
  25. Shanahan, C.J., Boonstra, F.M.C., Cofré Lizama, L.E., Strik, M., Moffat, B.A., Khan, F., Kilpatrick, T.J., van der Walt, A., Galea, M.P., Kolbe, S.C.: Technologies for Advanced Gait and Balance Assessments in People with Multiple Sclerosis. *Front. Neurol.* 8, (2018). doi:10.3389/fneur.2017.00708
  26. Park, D.-S., Lee, G.: Validity and reliability of balance assessment software using the Nintendo Wii balance board: usability and validation. *J. Neuroeng. Rehabil.* 11, 99 (2014). doi:10.1186/1743-0003-11-99
  27. Clark, R.A., McGough, R., Paterson, K.: Reliability of an inexpensive and portable dynamic weight bearing asymmetry assessment system incorporating dual Nintendo Wii Balance Boards. *Gait Posture.* 34, 288–91 (2011). doi:10.1016/j.gaitpost.2011.04.010
  28. Goble, D.J., Cone, B.L., Fling, B.W.: Using the Wii Fit as a tool for balance assessment and neurorehabilitation: the first half decade of “Wii-search.” *J. Neuroeng. Rehabil.* 11, 12 (2014). doi:10.1186/1743-0003-11-12
  29. Liuzzo, D.M., Peters, D.M., Middleton, A., Lanier, W., Chain, R., Barksdale, B., Fritz, S.L.: Measurements of Weight Bearing Asymmetry Using the Nintendo Wii Fit Balance Board Are Not Reliable for Older Adults and Individuals With Stroke. *J. Geriatr. Phys. Ther.* 40, 37–41 (2017). doi:10.1519/JPT.0000000000000065
  30. Reed-Jones, R.J., Dorgo, S., Hitchings, M.K., Bader, J.O.: WiiFit™ Plus balance test scores for the assessment of balance and mobility in older adults. *Gait Posture.* 36, 430–3 (2012). doi:10.1016/j.gaitpost.2012.03.027
  31. Livingstone, R., Paleg, G.: Measuring Outcomes for Children with Cerebral Palsy Who Use Gait Trainers. *Technologies.* 4, 22 (2016). doi:10.3390/technologies4030022
  32. Paleg, G., Livingstone, R.: Outcomes of gait trainer use in home and school settings for children with motor impairments: a systematic review. *Clin. Rehabil.* 29, 1077–1091 (2015). doi:10.1177/0269215514565947
  33. Michalska, A., Dudek, J., Bieniek, M., Tarasow-Zych, A., Zawadzka, K.: The application of the Balance Trainer parapodium in the therapy of children with cerebral palsy. *Fizjoterapia Pol.* 11, 273–285 (2011)
  34. Winter, D.A., Patla, A.E., Ishac, M., Gage, W.H.: Motor mechanisms of balance during quiet standing. *J. Electromyogr. Kinesiol.* 13, 49–56 (2003). doi:10.1016/S1050-6411(02)00085-8
  35. Winter, D.A., Prince, F., Frank, J.S., Powell, C., Zabjek, K.F.: Unified theory regarding A/P and M/L balance in quiet stance. *J. Neurophysiol.* 75, 2334–2343 (1996). doi:10.1152/jn.1996.75.6.2334
  36. Colombo, G., Joerg, M., Schreier, R., Dietz, V.: Treadmill training of paraplegic patients using a robotic orthosis. *J. Rehabil. Res. Dev.* 37, 693–700 (2000)
  37. Jezernik, S., Colombo, G., Keller, T., Frueh, H., Morari, M.: Robotic Orthosis Lokomat: A Rehabilitation and Research Tool. *Neuromodulation Technol. Neural Interface.* 6, 108–115 (2003). doi:10.1046/j.1525-1403.2003.03017.x
  38. Noé, F., Quaine, F.: Insertion of the force applied to handles into centre of pressure calculation modifies the amplitude of centre of pressure shifts. *Gait Posture.* 24, 382–385 (2006). doi:10.1016/j.gaitpost.2005.10.001
  39. Sieklicki, W., Barański, R., Grocholski, S., Matejek, P., Dyrda, M., Klepacki, K.: A new rehabilitation device for balance impaired individuals. In: *BIODEVICES 2019 - 12th International Conference on Biomedical Electronics and Devices, Proceedings; Part of 12th International Joint Conference on Biomedical Engineering Systems and Technologies, BIOSTEC 2019* (2019)

40. Elliott, D.B., Flanagan, J.: ASSESSMENT OF VISUAL FUNCTION. In: ELLIOTT, D.B. (ed.) *Clinical Procedures in Primary Eye Care*. pp. 29–81. Elsevier (2007)
41. Ghasia, F., Brunstom, J., Tychsen, L.: Visual acuity and visually evoked responses in children with cerebral palsy: Gross Motor Function Classification Scale. *Br. J. Ophthalmol.* 93, 1068–1072 (2009). doi:10.1136/bjo.2008.156372
42. Jacobson, B.H., Thompson, B., Wallace, T., Brown, L., Rial, C.: Independent static balance training contributes to increased stability and functional capacity in community-dwelling elderly people: a randomized controlled trial. *Clin. Rehabil.* 25, 549–556 (2011). doi:10.1177/0269215510392390
43. Veneman, J.F., Kruidhof, R., Hekman, E.E.G., Ekkelenkamp, R., Van Asseldonk, E.H.F., van der Kooij, H.: Design and evaluation of the LOPES exoskeleton robot for interactive gait rehabilitation. *IEEE Trans. Neural Syst. Rehabil. Eng.* 15, 379–86 (2007). doi:10.1109/TNSRE.2003.818185
44. Bayona, N.A., Bitensky, J., Salter, K., Teasell, R.: The Role of Task-Specific Training in Rehabilitation Therapies. *Top. Stroke Rehabil.* 12, 58–65 (2005). doi:10.1310/BQM5-6YGB-MVJ5-WVCR
45. Kilgard, M.P.: Cortical Map Reorganization Enabled by Nucleus Basalis Activity. *Science* (80- ). 279, 1714–1718 (1998). doi:10.1126/science.279.5357.1714
46. Matjacić, Z., Johannesen, I.L., Sinkjaer, T.: A multi-purpose rehabilitation frame: a novel apparatus for balance training during standing of neurologically impaired individuals. *J. Rehabil. Res. Dev.* 37, 681–91 (2000)
47. Walker Catherine, Brouwer J Brenda, Culham G Elsie: Use of Visual Feedback in Retraining Balance Following Acute Stroke. *Phys. Ther.* 80, 886–895 (2000). doi:10.1093/ptj/80.9.886
48. Pasma, J.H., Engelhart, D., Schouten, A.C., van der Kooij, H., Maier, A.B., Meskers, C.G.M.: Impaired standing balance: The clinical need for closing the loop. *Neuroscience*. 267, 157–165 (2014). doi:10.1016/j.neuroscience.2014.02.030
49. Mancini, M., Horak, F.B.: The relevance of clinical balance assessment tools to differentiate balance deficits. *Eur. J. Phys. Rehabil. Med.* 46, 239–248 (2010)
50. Bailey, I.L., Lovie, J.E.: New design principles for visual acuity letter charts. *Am. J. Optom. Physiol. Opt.* 53, 740–5 (1976)
51. Stoller, O., Rosemeyer, H., Baur, H., Schindelholz, M., Hunt, K.J., Radlinger, L., Schuster-Amft, C.: Short-time weight-bearing capacity assessment for non-ambulatory patients with subacute stroke: reliability and discriminative power. *BMC Res. Notes*. 8, 723 (2015). doi:10.1186/s13104-015-1722-7
52. Rogers, M.W., Martinez, K.M., Waller, S.M., Gray, V.L.: Recovery and Rehabilitation of Standing Balance After Stroke. In: *Stroke Recovery and Rehabilitation*. pp. 343–374. Springer Publishing Company, New York, NY (2009)
53. Goldie, P.A., Matyas, T.A., Evans, O.M., Galea, M.P., Bach, T.M.: Maximum voluntary weight-bearing by the affected and unaffected legs in standing following stroke. *Clin. Biomech. (Bristol, Avon)*. 11, 333–342 (1996)
54. Rougier, P.R., Genthon, N.: Dynamical assessment of weight-bearing asymmetry during upright quiet stance in humans. *Gait Posture*. 29, 437–443 (2009). doi:10.1016/j.gaitpost.2008.11.001
55. Kamphuis, J.F., de Kam, D., Geurts, A.C.H., Weerdesteyn, V.: Is Weight-Bearing Asymmetry Associated with Postural Instability after Stroke? A Systematic Review. *Stroke Res. Treat.* 2013, 1–13 (2013). doi:10.1155/2013/692137

