

This is the peer reviewed version of the following article: Witkiewicz Z., Wardencki W. and Neffe S. (2021), Mobile Chromatographs and Spectrometers for the Analysis of Chemical Warfare Agents. In Encyclopedia of Analytical Chemistry, R.A. Meyers (Ed.), which has been published in final form at <https://doi.org/10.1002/9780470027318.a9748>. This article may be used for non-commercial purposes in accordance with Wiley Terms and Conditions for Use of Self-Archived Versions.

Title: *Mobile chromatographs and spectrometers for the analysis of Chemical Warfare Agents*

Authors: Zygfryd Witkiewicz¹), Waldemar Wardencki²), Sławomir Neffe¹)

¹*Institute of Chemistry, Military University of Technology, Warsaw, Poland*

²*Department of Analytical Chemistry, Chemical Faculty, Gdansk University of Technology, Gdansk, Poland*

Abstract

*This article describes the **technological state of readiness regarding** mobile chromatographs and spectrometers, and their applicability for the analysis of chemical warfare agents, **degradation products**, simulants, and precursors. Application of chromatographic techniques and instruments, which are useful for the screening and analysis of Chemical Weapons Convention (CWC) related chemicals, are described. Proper choice of mobile equipment and its applicability for detection of Chemical Warfare Agents (CWA) are discussed. Various miniaturised detectors and analytical procedures are described. The analytical techniques and advanced software for large amount of analytical data management are important factors when performing the on-site analysis for security and forensic needs. Advantages and disadvantages of mobile instruments in comparison with the laboratory equipment are presented.*

1 INTRODUCTION

The contemporary **movement** in analytical chemistry **is** to perform analysis at the place where analytes are present. It is very important to receive reliable results of an analysis in short time and without sampling of investigated material and transporting samples to stationary laboratories. It is especially important in the military, strengthening security, forensic and antiterrorist operations [1].

First responders, analysts and staff involved in antiterrorist operations have nowadays transportable and portable instruments, mainly based on chromatographic techniques of analyte separation and identification, with excellent technical parameters, **with** analytical capabilities are similar to laboratory instruments. Some technical solutions developed for

mobile instruments are very interesting and probably will be applicable in stationary laboratory instruments.

Miniaturization of conventional instruments, besides higher portability, provides many advantages such as: low-power requirements, low heat capacity of separation columns, low consumption of stationary and mobile phases, enhanced performance, better mass sensitivity and easier coupling to detectors and secondary chromatographic systems [2].

Gas chromatographs, mass spectrometers and ion mobility spectrometers are used for field analysis of chemical warfare agents (CWA). Each of these instruments alone and in different connections with others can be used for CWA and toxic industrial chemicals (TIC) analysis. Currently, gas chromatographs equipped with ordinary, non-selective and non-specific detectors are rarely used. The best properties are demonstrated by instruments that are a gas chromatograph (GC) coupled with a mass spectrometer (MS) or/and an ion mobility spectrometer (IMS).

Detecting, identifying, and quantifying of CWA on the battlefield is a difficult task. They may occur at very low concentrations in the presence of many other substances that may give similar analytical signals as CWA. It is therefore important that the instruments used for CWA analysis should have very good sensitivity, selectivity, and the ability to identify detected substances.

2 CHARACTERISTICS OF MOBILE GAS CHROMATOGRAPHS

The miniaturization of the complex separation systems is one of the directions of development of separation techniques. This trend has been observed since the beginning of the practice of two main chromatography techniques, i.e. gas chromatography (GC) and liquid chromatography (LC). Miniaturization in gas chromatography began with the use of columns with smaller internal diameters, and the beginning was the introduction by Marcel J.E. Golay capillary columns in the 1950s. In addition to the traditional miniature column chromatography techniques that led to micro-GC systems, lab-on-chip have been developed since the 1970s. Simple systems were initially developed into complex lab-on-a-chip platforms [3] to perform a complete sample analysis: its collection and preparation (purification, concentration, derivatization of analytes), separation of ingredients, their detection and identification.

Mobile gas chromatographs are usually not as universal as laboratory GC and are frequently destined for analysis of specific groups of analytes, e.g. hydrocarbons or different groups of chemical agents but have no disadvantages of full-size laboratory chromatographs.



Several types of mobile gas chromatographs are distinguished [4]. The largest mobile devices are weighted by tens of kilograms (kg) and are usually transported on vehicles to measuring points. Such devices are often part of typical equipment of mobile laboratories. Devices whose weight does not exceed 25 kg are treated as person-portable or hand-held instruments.

Person-portable chromatographs are generally smaller and lighter compared to conventional chromatographs and consume less energy. They are usually powered by batteries and are equipped with small gas cylinders. Among the person-portable instruments are devices whose weight does not exceed 1 kg, but there are also devices obtained using micro-electro-mechanical systems (MEMS). MEMS technology enables the production of entire devices as well as their components on a micrometer scale, creating micro-GC systems [5]. Very useful in downsizing of gas chromatographs are also recent development in fabrication of polymeric materials based on metalorganic structures (Metal Organic Framework - MOF).

Mobile chromatographs are currently produced using the latest achievements of modern technology allowing to produce devices with parameters fully comparable to laboratory chromatographs. Some of the latest solutions introduced in mobile chromatographs are not even used in laboratory instruments. Their functionality and quality of analysis produce results comparable to those of conventional devices. Some of them can work unattended for long periods of time as monitoring devices being able to provide the results from long distances, e.g. from the ocean or from the space to the Earth.

Mobile chromatograph thermostats have a compact design which allows the column to heat up to 400°C when using different temperature programming variants and cooling of the columns from 250°C to 50°C in less than 5 minutes.

Designs with two thermostats are used. The eluate from the first column can be introduced into the second column, which is in the second thermostat, where the separation of non-separated components in the first column continues. This solution is used in fast and two-dimensional chromatography.

Liquid and gas samples can be entered into a column when the various types of injectors are used. Up to 5 injectors can be placed in a single chromatograph. There are solutions in which integrated systems for pre-enrichment or sample preparation are installed. For example, two parallel sorption traps are used in which analytes are desorbed by thermal desorption. Additionally, purge and trap and static head space analyses are also used. The



injectors may be connected to the 10-port valve enabling simultaneous separation of samples in two columns, or column switching and changing carrier gas flow direction.

All types of detectors can be used in mobile gas chromatographs. Systems where 6 different detectors are installed are known. The detectors can work as single devices or can work connected in series, e. g. as in TCD-methanizer-FID system. Air for FID is supplied from a quietly working compressor.

Miniaturization of key elements of mobile GC instruments is still increasingly investigated to obtain high performance separation systems.

3 CHARACTERISTICS OF MOBILE MASS SPECTROMETERS

Mass spectrometry is a very useful analytical tool for both qualitative and quantitative analysis of complex mixtures. The mass spectrometer consists essentially of an ionization source, which produces a beam of ions, an analyzer which separates ions according to the m/z ratio, and a collector/detector (usually electron multiplier) which determines the fraction of the total ion current carried by each of the ion. Other important components of MS systems include a vacuum system, instrument control panel and a data acquisition system.

The first mass spectrometer was constructed in 1912 and was designed to analyze simple inorganic molecules. Today, because of technological improvements, mainly MEMS in combination with microfluids systems, the mass spectrometer allows the determination of various analytes, including biological macromolecules.

This possibility is the result of, among other things, introducing mild ionization techniques, such as electrospray ionization (ESI) and matrix-assisted laser desorption ionization (MALDI) that allow the conversion of biomolecules into ions. ESI can efficiently be interfaced with separation techniques enhancing their roles in the life and health sciences. MALDI, however, has the advantage of producing singly charged ions of peptides and proteins, minimizing spectral complexity. Regardless of the ionization source, the sensitivity of a mass spectrometer is related to the mass analyser where ion separation occurs. Both quadrupole and time of flight (TOF) mass analysers are commonly used, and they can be configured together as Q-TOF tandem mass spectrometric instruments. Tandem mass spectrometry (MS/MS) is the result of coupling two or more mass analysers. Coupling of a quadrupole and TOF instrument resulted in the production of high-resolution mass spectrometers.

Mass spectrometers have long been too complex, too large, too heavy, as well as too power-consuming to be used as mobile devices. However, thanks to the development of size



reduction technology and new methodological solutions over the past twenty years, several types of miniature mass spectrometers (MMS), understood as a portable (field-deployable) or handheld devices, have been achieved. The basic building elements in miniature mass spectrometers are similar in composition to the laboratory instruments. The three most important elements contributing to miniaturization are the mass analyzer, vacuum system, and electronics control system.

Although reducing the size of mass spectrometers can lead to poorer performance of the device compared to laboratory spectrometers, the mass spectrometers thumbnails are designed to achieve the right resolution, low limit of detection, satisfactory accuracy and, above all, the possibility of automatic operation. In many chip-based element designs, in addition to other benefits, the operations performed during the analysis were simplified.

An important solution for reducing the size of spectrometers are sample injection port systems, in which ions can be produced under ambient as well as in the open-air conditions without prior sample preparation [7]. It has been shown that compatible with MMS are different ambient ionization methods, including low-temperature plasma, paper spray, and extraction spray.

Ambient mass spectrometry (AMS) has become increasingly important in the last 15 years thanks to the ability to analyze multiple substances at the level of traces in complex matrices, with little pre-preparation of the sample or even without preparation [8].

AMS allows for in-situ analysis quickly and in real time, usually combined with high resolution mass spectrometry. Among AMS techniques, paper spray ionization (PSI) is particularly popular thanks to its simplicity, versatility, sensitivity, and cost-effectiveness. Since its introduction in 2010, PSI has been successfully used to analyze pharmaceuticals and metabolites in biological samples, forensics, and food analysis.

Among the mass analyzers in MMS design, the most interesting are the ion trap analyzers (quadrupole ion trap or Paul trap, transform ion cyclotron and newly developed orbitrap). They are much smaller than beam-type mass analyzers, such as TOF and sector mass analyzers. In addition, ion trap analyzers can be used to perform multistage MS/MS in a single device. One of the advantages of the new traps is the ability to operate at higher pressures than beam-type analyzers.

The vacuum system, which includes a vacuum pump and a vacuum manifold with its interfaces, is usually the largest component of the mass spectrometer and consumes the most electricity. MMS uses miniature-turbo pump configurations like lab-scale instruments.



The latest pumps weigh just 500 g and consume 18 watts of power, providing a pressure of 10^{-8} torr [9].

There is a series of mini mass spectrometers based on quadrupole ion trap called Mini 10, Mini 11, and Mini 12 [10]. The mass of Mini MS 10 with electrospray ionization and paper spray ionization is 10 kg. The 8.5 kg Mini-11 and 25 kg Mini 12 can provide resolution mass spectra up to m/z 600. Mini-12 can analyze directly complex samples without sample preparation or, to some extent, without chromatographic separation.

The MMS 1000 was originally designed for NASA for monitoring air quality on the International Space Station. This model is a cylindrical ion-trap MS with MS/MS capability. MMS 1000 allows for compounds to be analyzed in a wide range of molecular masses (35-450 Da) with a resolution less than 0.5 Da. The other two miniature spectrometers are handheld M908 (2 kg) with solid, liquid, and gas multi-phase detector, and spectrometer 3500 and 4000 uses single quadrupole mass analyzer [11]. There are several other instruments fabricated using ion trap mass analyzers such as Tridion-9 and Chemsense 600.

4 CHARACTERISTICS OF ION MOBILITY SPECTROMETERS

Ion mobility spectrometry (IMS) is an analytical technique involving the use of ion movement in the gas phase (drift gas) in the electric field [12-14]. Ions are formed by ionization of molecules of the analyzed substances and in the electric field move at different speeds. The mobility of the ions depends on their weight, electric charge, and shape. The analysis of mixtures of chemical compounds using IMS consists of the stage of ion formation in the reaction section of the spectrometer and the separation of the resulting ions in its drift section. In most instruments, ionization is carried out using radioactive isotopes, usually ^{63}Ni or ^{241}Am , photoionization, corona discharge or laser beam. In addition to the analyte ions, reaction ions are formed because of ionization of drift gas and its admixtures. The effectiveness of ionization of individual analytes, which affects their detection and selectivity, depends on their properties. The effectiveness of ionization can be influenced by the addition of doped gases, the so-called dopants, which form additional reaction ions. Ions created by analytes can be positive or negative. In the case of CWA, positive ions are mainly formed, only some substances form negative ions.

In individual IMS techniques, ion generation is very similar. However, their mobility in the electric field is used differently. In general, this consists in the movement of ions to the electrode on which the analytical signal is produced. Ion mobility spectrometers are characterized by having a very good limit of detection (LOD) but generally poor resolution.



Their action is influenced by air humidity and substances occurring in their surroundings, which is common on the battlefield. Three basic IMS techniques are known: drift tube, field asymmetric and aspiration.

Drift tube IMS (DT IMS) is a technique in which ions created in the reaction section are entered into the drift section by periodically opening the dosing grid [Fig. 1].

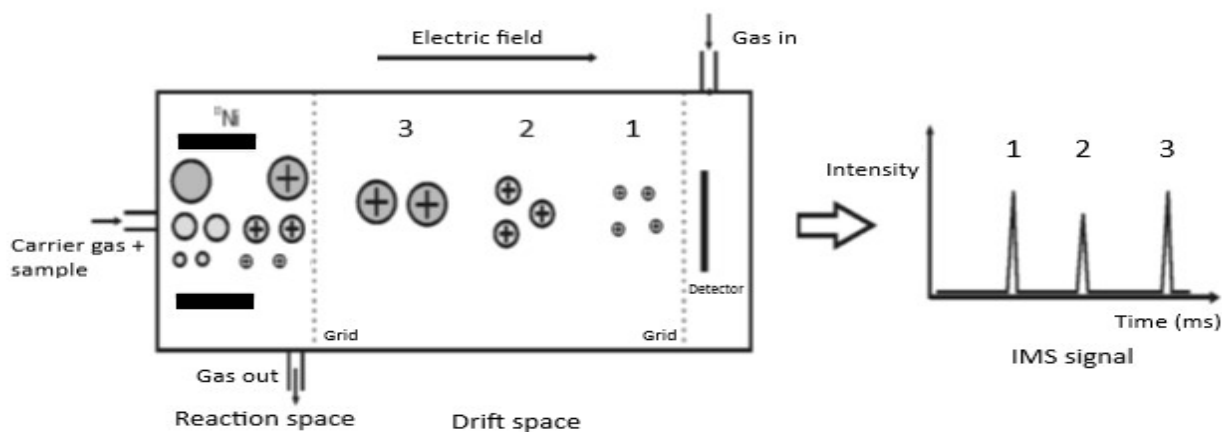

Fig. 1. Principle of operation of Drift Tube Ion Mobility Spectrometer.

The electrical field existing in the cylindrical drift section causes the ion movement, corresponding to the lines of the field, towards the bulk electrode. Ions with different properties reach the electrode at different times, triggering current output signals. The movement of ions occurs in unionized drift gas moving in the opposite direction to the movement of ions. Signals are obtained in the form of peaks, the drift time of which is characterized by qualitative substances and their size quantitatively. The resolution of the output signals is influenced by the length of the drift-chamber, but usually it does not exceed over 12 centimeters. Spectrometers using this ion separation technique are most used in portable and transportable instruments.

DT IMS has several advantages over MS. It can distinguish between isomers which is not possible with MS. Due to the separation of individual ions, not only based on m/z coefficient but also on their active cross-section, the problem of their distinction in mass spectrum decreases. DT IMS can be easily combined with time-of-flight MS instruments, obtaining combined information in the form of drift time and mass spectrum [15].

Field asymmetric ion mobility spectrometry (FAIMS) is now more commonly referred to as differential mobility spectrometry (DMS) [Fig. 2].

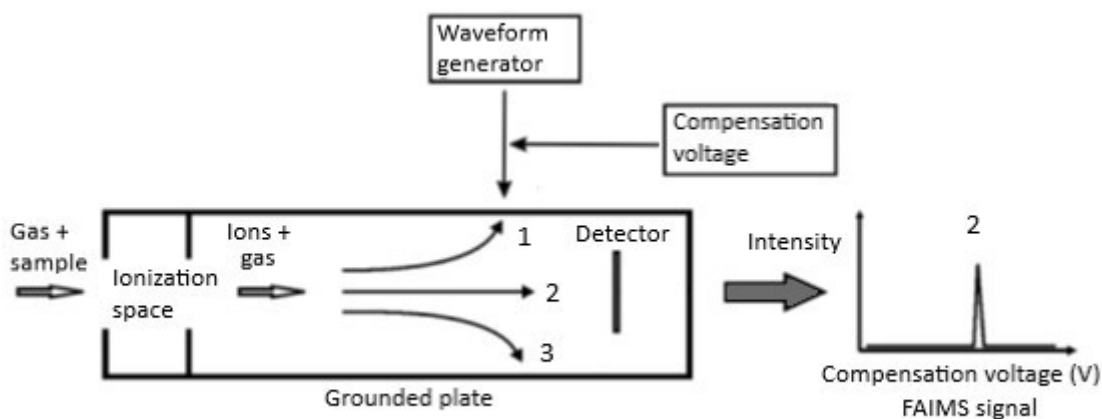

Fig. 2. The operating principle of [Field Asymmetric Ion Mobility Spectrometer](#).

In this analytical technique, ions produced in the reaction section are transferred in the carrier gas stream to a separator made of two parallel plates. These plates are electrodes used to produce a perpendicular variable electric field. This field is produced by attaching separation voltage to the electrodes of a radio frequency. Ions transferred in the carrier gas, e.g. filtered air, oscillate between electrodes and [become](#) neutralized on them. The strong asymmetry of the electric field in the separator makes the ion mobility value different for both directions of oscillating motion. Adding a constant component to the variable separation voltage in the form of compensating voltage allows the ion to pass with a specified mobility throughout the separator. It is neutralized at the end of the separator on the bulk electrode. The identification of ions is based on the compensating voltage value, which allows them to pass through the entire separator. The output signal of the DMS spectrometer is the relationship of the current of the aggregate electrode to the compensating voltage. The advantage of FAIMS (DMS) is simple, compact design and the ability to simultaneously record negative and positive ions at potentially high resolution. DMS can be easily miniaturized using micro-electro-mechanical systems (MEMS) [16].

Aspiration IMS (AIMS). In this analytical technique, the molecules after ionization move in a orthogonal electric field interacting with many electrodes placed on the walls of the drift chamber (Fig. 3).

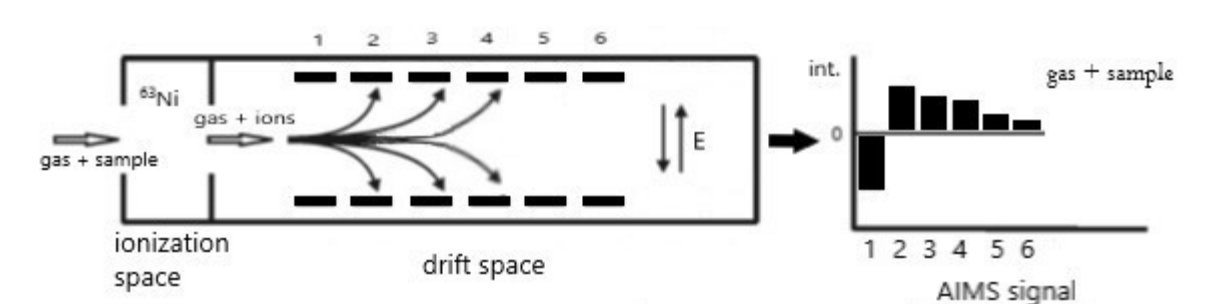

Fig. 3. Principle of operation of Aspiration Ion Mobility Spectrometer.

Drift gas flows through this chamber in the same direction as the ions move. Individual ions, positive and negative, interact with different electrodes, giving a specific picture of the signals coming from these ions. With continuous flow of drift gas it is possible to continuously detect the chemicals present in it.

Ion mobility spectrometers due to their principle of operation and low energy consumption are small, light portable instruments [13].

5 EXAMPLES OF APPLICATIONS OF MASS SPECTROMETERS

Mass spectrometers as single instruments still have little use for CWA analysis, but research in this regard is still being carried out. An example of this is analysis of sulfur mustard and precursors of organophosphorus CWA: 2-chloroethylethyl sulfide (CEES), salicylate (MeS) diethyl methyl phosphonate (DEMP), dimethyl methyl phosphonate (DMMP) and methyl salicylate (MeS) in air using a miniature cylindrical ion trap mass analyzer [17]. A glow discharge electron ionization was used for ionization of analytes. The instrument itself weighed 25 kg, power supply and nitrogen were taken from the deck of the vehicle. Air samples containing these analytes were trapped into sorption tubes containing Tenax TA and Carboxen 569. Then, the thermodesorption was performed in 90 seconds using dual-tube thermal desorber. The limit of detection of the studied simulants ranged from 0.26 to 5 parts per billion (ppb). The presence of several CWA simulants and other substances, e.g. emissions from internal combustion engines did not allow for the unambiguous identification of analytes. Identification and quantitative determination were only possible when the MS/MS detector was used.

A new approach to scan using a single linear quadrupole ion trap has been used to receive a two-dimensional mass spectrum. A single scan received sufficient information to detect and identify four CWA of VX-series. The developed method intends to be implemented in the form of a portable instrument [18].

Sulfur mustard, phosgene and hydrogen cyanide were detected using a portable mass spectrometer with electron cyclotron resonance ion source. Sulfur mustard was detected at ppm level. CWA formed monoatomic ions, fragment ions and molecular ions. On this basis, it was possible to identify individual CWA [19].

In addition to commonly used ways of ionizing of CWA in recent years, paper spray ionization is becoming increasingly important. This ionization method is simple and requires little or no sample preparation. Research on this method of detecting and identifying CWA indicates that it may be used in mobile MS [20, 21].

6 EXAMPLES OF APPLICATION OF ION MOBILITY SPECTROMETERS

IMS are the most widely used military CWA detection instruments. Many armies are equipped with such detectors in the form of different versions of the instrument known as Chemical Agents Monitor (CAM) and Lightweight Chemical Detector (LCD). This is due to their very good detectability, the short time needed to receive analytical information, simplicity of use, low weight and dimensions and low energy consumption [22]. They are also cheap to operate as they do not require the use of additional expensive consumables. The drawbacks of the IMS monitors include relatively low selectivity and the ability to detect many substances that are not CWA, what may cause false positive and negative alarms of the instrument. Some IMS shortfalls can be reduced by coupling it with mass spectrometry [23, 24] and especially with gas chromatography.

Using IMS based equipment is the easiest way to analyze substances that are present in the air. In many instruments, samples of the analyzed air can be introduced directly into the detector. In some cases, gases are supplied through membranes to limit the penetration of interfering substances into the drift chamber of instrument during the analysis.

DT IMS in the form of the Portable SABRE 4000 instrument allows detection and alarming of the presence of soman, sarin, cyclohexylsarin, tabun and nitrogen mustard in the air in the range of 0.005 – 0.5 mg/m³ in the form of positive ions. Sulfur mustard and some other chemical agents were detected in the concentration range of 0.2 – 2 mg/m³ as negative ions [25]. Simulants of nerve and blister agents were also detected. Of the seven simulants and 28 other organic solvents, only 6 gave false CWA detection alarms. Some analytes were detected as positive ions and some in the form of negative ions. This instrument is also designed for the detection and identification of drugs and explosives. For this purpose, the software is equipped with a library of the IMS spectra of chemical compounds to be detected and identified.



The detectability of nerve, blister, choking agents and related chemicals was studied using the Aspirant M90-D1-C model instrument [26]. ^{241}Am was used as a source of ionization of analyte molecules. The level of detection was less than 0.3 mg/m^3 for a sulfur mustard, and for several other toxic substances less than 2.4 mg/m^3 . Some chemicals, including CWA simulants and solvents, gave positive results, as did CWA. Signals indicating chemical agents were also detected when nerve, blister, blood, choking agents, lachrymators, simulants, and organic solvents were detected. Corona discharge and ammonia dopant were used in the instrument.

Using DMS various CWAs [27], organophosphorus compounds [28] and simulants of blister agent [30] were analyzed. Increased analytical capabilities occur because of a DT IMS coupling to DMS. Sarin, soman, tabun and VX were detected and identified with such an instrument.

In the case of V-agents, G-agents, and sulfur mustard detection in liquid and solid matrixes, the SPME technique [12, 31, 32] is used to insert samples into the IMS ionization chamber. In water, a malathion with concentration of $0.96 \text{ }\mu\text{g/L}$ was detected using IMS with corona discharge ionization and SPME extraction. Other organophosphorus compounds can also be detected using such an instrument [18].

As with other instruments, there is a tendency to miniaturize ion mobility spectrometers. Sarin, soman, tabun, VX, sulfur mustard and Lewisite were detected at ppb concentrations using miniature DMS made by means of MEMS technology [33]. Detection was seamless when single chemical agents were detected. Their identification was not satisfactory in the presence of interferences. According to the authors, this defect could be removed using dopant gas.

The general characteristics of IMS and its use for CWA analysis are described in Mäkinen et. all. review [12], and later in Puton and Namiesnik review [34]. The uses of FAIMS and DMS, including CWA analysis, are described in the Kolakowski and Mester review [35].

7 GENERAL CHARACTERISTICS OF GC-MS AND GC-IMS MOBILE INSTRUMENTS

Mobile gas chromatographs with classical nonselective detectors do not have practical application on the battlefield due to either insufficient level of detection or the specific requirements of detectors concerning e. g. carrier gas. There are instruments in which sensors or matrix sensors are used as detectors. A gas micro chromatograph with matrix sensors

detector has made it possible to separate and detect **DMMP, DEMP and MeS** within 60 s. [36].

However, the sensors do not have the ability to reliably identify analytes with the required level of detection. This ability has mass and ion mobility spectrometers. However, they have a disadvantage in the fact that, in the case of complex mixtures or substances whose spectrum is not included in the instrument libraries, their analysis is very difficult or impossible. In such cases, much better results are achieved using hybrid instruments in the form of a combination of spectrometers with gas chromatographs. The analysis by means of such instruments consists of the introduction of the sample into the chromatographic column, the separation of the sample components and the recording of their retention times, and then the generation of the ions of these components followed by their identification by mass spectra or drift times. As a result, mobile GC-MS and GC-IMS meet or approach to meet the requirements of the modern battlefield. They make it possible to detect toxic chemicals with a sample as little as possible, its identification and quantitative determination. This should be possible in the presence of other substances, often present on the battlefield.

Frequently, mass spectrometry is coupled with separation techniques like gas chromatography, liquid chromatography, or electrophoresis. These combinations reduce matrix effects, lower background effects, and improve selectivity, especially when analytes occur at different concentration levels. MS with GC (GC-MS) is very common [37]. An example of a GC-MS device is Bruker's MM2 spectrometer. It is military, hardened, mobile and lightweight GC-MS system. The mass spectrometer in this unit is an example of a new generation of the quadrupole mass analyzer (QMS) with membrane inlet. It has a novel vacuum system and micro-controller technology. The system is equipped with a surface probe and a thermal desorber. The whole **instrument** weighs 35 kg. It can be easily mounted on all types of vehicle platforms.

In chromatographs coupled with spectrometers, columns are usually between 5 and 15 m long and internal diameters from 0.1 to 0.4 mm. Multicapillary columns, consisting of several hundred microcapillars, less than one meter in length are also used [28]. The thickness of the film of the stationary phase is the tenth part of the micrometer. Stationary phases shall be selected depending on the expected group of substances to be detected. For most CWA, phases with medium polarity are good, e.g. MXT-5 [38] or non-polar [39].

Hybrid instruments use columns heated in such a way that they can be used in a rapid gas chromatography regime. The columns are placed in compact thermostats with direct heating. This allows the separation of complex mixtures in a short time.



If the chromatograph is coupled with a mass spectrometer, the mass spectrum of the individual components is obtained. If chromatograph is coupled with an ion mobility spectrometer, ion mobility spectrum or compensation voltage values are obtained. Two-dimensional information is obtained from both systems. For GC-MS, these are retention times and mass spectrum of individual components of the mixture. In the case of GC-IMS, these are retention times and drift times of these components.

Hybrid instruments have robust structures, suitable for use on the battlefield and friendly software that enables them to be operated by a user who does not have special education and operate in personal protective equipment.

Spectrometers are designed to detect chemical compounds whose ions have a m/z ratio between 40 and 500. Spectral libraries are equipped with a spectra of chemical compounds that may be present on the battlefield. Some programs allow the deconvolution of peaks and the identification of substances whose peaks are not perfectly separated [40].

For easier identification of CWA in mixtures with other chemicals, two-dimensional gas chromatography [41] and IMS-MS coupled detectors [15, 42] are used in field conditions. In such instruments IMS is used to separate the components of the mixture and MS to identify them. IMS can separate ions with the same m/z that are isomers. The portable instrument that is a combination of IMS with MS is described in work of Manard et. all. [43]. Portable FAIMS combined with miniature MS produce instruments with high analytical capabilities.

Gas samples shall be introduced into GC-MS and GC-IMS instruments directly, sometimes through membranes or by adsorption in sorption tubes and then through thermal desorption. Liquid samples are usually dosed using SPME [38] technology, including head space. Liquids from porous surfaces can be wiped with absorbent material from which analytes evaporate and are introduced into the sample injector. Analytes are also evaporated from solids, e.g. soil, what is described in papers [44, 45].

8 SPECIFIC CHARACTERISTICS OF GC-MS INSTRUMENTS

In instruments combining a gas chromatograph with a mass spectrometer, miniature toroidal and cylindrical ion traps, or quadrupole mass analyzer are often used [40, 46]. The former give mass spectra easy to interpret. A serious problem with quadrupole mass spectrometers is the need to create a very high vacuum in them. In ionic traps, this is not so important, so vacuum pumps can be simpler and their energy needs are lower [47]. In addition to mechanical pumps, non-evaporative getter chemical pumps are used. Chemical pumps are smaller and lighter than mechanical ones but have limited service life and require frequent

replacement [48]. GC-MS instruments are usually heavier than GC-IMS due to the presence of the pump and are less likely to be portable than transportable [49]. Toroidal ion trap spectrometer allows ions to be recorded in the range of m/z factor from 50 to 442 [38] and quadrupole mass spectrometer from 45 to 300 [37].

GC-MS instruments are very well suited for CWA detection and analysis on the battlefield. In some armed forces, they are mounted in field laboratories and in vehicles directly involved in combat operations. In some instruments it is possible to inject the sample into the spectrometer directly or through the membrane bypassing the chromatographic column [40]. Then the spectrometer can act independently as a chemical agent monitor. In this case, the analysis time is significantly reduced. This solution is used when a substance with a characteristic m/z value is being sought, that otherwise is not naturally present in the environment. In other cases, a complete GC-MS system is used. In the first case, the analyte is detected in real time and in the second case it takes a few minutes to detect it.

Comparison of analytical capabilities of the field-portable gas chromatographs equipped with cylindrical ion trap (Griffin 450) and transmission quadrupole spectrometers (5975T) has been carried out in the study of Ohuri et al. [54]. The study was performed on the example of VX analysis and six products of its destruction. The quadrupole mass spectrometer, using retention indices, made it possible to identify these analytes very well. In the case of ion trap spectrometer, identification was impossible because mass spectra depended on analyte concentrations, and ion dimers were formed.

Using spectrometers coupled with gas chromatographs, CWA present in air, water, soil, and solid surfaces, for example armament, can be analyzed. Depending on the analyzed material under consideration, different methods of preparation and injection samples into the column of instrument are used. In the case of air analysis, it can be injected directly, automatically through the dosing system, using a six-way valve. SPME is used for the analysis of liquids (mainly water) or solids (e.g. soil). For the analysis of liquid substances on the surface of equipment or weapons, these substances may be wiped with the fibrous material (e.g. Teflon cotton wool), from which they are then thermally desorbed in the instrument injector [55].

One of the instruments that is used by the military is Hapsite ER. These instruments are suitable for air analysis as well as the head space of water and soil. Using the Hapsite instrument sarin, soman, tabun and sulfur mustard mixture was separated within 8 minutes with their limit of detection: 0.2, 0.5, 8 and $0.3 \mu\text{g} / \text{m}^3$, respectively [39]. A sample gas can be introduced into this instrument by thermal desorption of previously adsorbed analytes.



Analytes were identified using GC-MS, based on mass spectra using the NIST database. Quantitative analysis was performed using calibration with isotope-labeled diethyl malonate molecules [53]. Low volatile VX and RVX agents were detected using the same instrument [54]. In this case, after a preliminary concentration of the analytes, they were converted into volatile fluorine derivatives with silver nitrate and potassium fluoride. As a result, VX and RVX were detected at the $LOD = 0.3 \text{ mg} / \text{m}^3$.

GC-MS are useful for analyzing organophosphorus precursors and degradation products of some of CWA. Using the GC-MS 5975T instrument, trimethyl phosphate, triethyl phosphate, tripropyl phosphate and tributyl phosphate were separated very well within 5.5 min [55]. VX degradation products were analyzed using hand portable gas chromatograph with toroidal ion trap spectrometer [56].

GC-MS instruments are now standard equipment for many military mobile laboratories. Transportable GC-MS EM 640 can be used to detect CWA in the air when sampling using sorption tubes and SPME. The limit of detection of soman, VX and sulfur mustard was 0.07, 0.02 and 0.02 mg / m^3 in the first case and 5, 2 and 2 mg / m^3 in the second case, respectively. The analysis took 20 minutes in both cases [57].

Several companies producing analytical apparatus, mainly gas chromatographs, produce many models of mobile devices that combine gas chromatograph with mass spectrometer. These are, for example, Hapsite, Griffin, E2M, and PerkinElmer. These instruments allow the analysis of the CWA in the field conditions. Some companies offer networks, in which individual instruments have direct communication with the headquarters for databases, analyte identification software, data storage, and reporting.

9 SPECIFIC CHARACTERISTICS OF GC-IMS INSTRUMENTS

GC-IMS sets are less complex, cheaper, and easier to use than GC-MS connections. Therefore, GC-IMS can be used in cases where more important than the measurement accuracy are such properties as: speed of analysis, very low detection limit, ease of use and high mobility. Such instruments are generally smaller and lighter than GC-MS. The combination of a GC capillary column with IMS technology does not cause such difficulties as a combination of GC with MS. However, there is a certain disproportion in the flow rate of carrier gas through the column, amounting to several cm^3/min and gas flowing through the IMS spectrometer in the amount of about $1 \text{ dm}^3/\text{min}$.

The chromatographic column can have a length of several meters and a diameter of up to 0.53 mm. A good solution is to couple IMS with a chromatograph equipped with a multi-



capillary column [58, 59]. The length of multi-capillary columns can be several tens centimetres. They allow for good separation under isothermal conditions in a short time, working in a fast gas chromatography regime.

IMS spectrometers have very good detectability, but a narrow dynamic range of the analytical signal [60]. This complicates the performance of quantitative determinations and in the case of high concentrations of the analyte, the device may be saturated, and time is needed to return it to a state that allows the next analysis to be performed. The same analyte, depending on the concentration, can occur in the mobility spectrum at different peaks, forming e.g. dimer ions.

The methods of interpreting the results of analyzes obtained with the use of GC-IMS instruments are constantly being improved [61]. It is intended that the description and interpretation of the spectra obtained can be performed automatically [62, 63]. An attempt was made to use artificial neural network to develop measurement data obtained from GC with multi-capillary columns and DT IMS [64]. As a rule, the instruments are equipped with software that facilitates the interpretation of the received data. The work [52] describes the method of interpretation of three-dimensional signals obtained during the analysis of tributyl phosphate, which is a precursor of organophosphorus CWA, using GC-IMS. Retention times, ion mobility spectra and peak intensities are mathematically converted into a flat colored image. The identification of a specific analyte is done by searching for parts of the image that differ from the background using data mining techniques and comparing them with the patterns stored in the device's memory. This method is particularly useful when identifying analytes in the air at low concentrations.

10 SUMMARY

Mobile GC-MS instruments have an advantage over GC-IMS devices in terms of selectivity, but the LOD of the latter is much higher. The advantage of GC-IMS is that they are largely portable while GC-MS are mainly transportable. GC-IMS devices operate under atmospheric pressure without vacuum generation systems.

For the analysis of CWA DT-IMS and FAIMS as single instruments are mainly used, while for the analysis of these chemical agents using hybrid instruments, GC-MS is mainly used. The instruments described in this review are not of great importance in the analysis of CWA destruction products. For this purpose, mobile liquid chromatographs would be useful but they have not yet had practical significance. However, portable capillary electrophoresis instruments [65] can have such an important meaning. They can be used to analyze products



of destruction of organophosphorus CWA which are in the form of phosphonic acids or their salts.

The analytical coupled techniques and advanced software for large amount of analytical data management are important factors when performing the on-site analysis for security and forensic needs. In the future, the growing role of artificial intelligence should be expected when improving mobile chemical analysis instruments developed for military, security, and forensics sectors.

ACKNOWLEDGMENTS

The work was co-financed from the funds of the Polish Ministry of Science and Higher Education as part of the implementation of the UGB 762/WAT/2020 project.

REFERENCES

1. A. Gałuszka, Z. Migaszewski, J. Namieśnik, Moving your laboratories to the field – Advantages and limitations of the use of field portable instruments in environmental sample analysis, *Environ. Res.*, **140**, 593-603 (2015).
2. Z. Witkiewicz, W. Wardencki, Transportable, portable and micro gas chromatographs, *Anal. Chem.: An Indian Journal*, **19**, 1-12 (2019).
3. F. Haghghi, Z. Talebpour, A. Sanati-Niezhad, Through the years with on-a-chip gas chromatography: a review, *Lab on a Chip*, **15**, 2559-2575 (2015).
4. P.A. Smith, Portable gas chromatography, in: *Analytical Separation Science*, eds. J.L. Anderson, A. Berthold, V.P. Estevez, A.M. Stalcup, Wiley-VCH Verlag GmbH&Co. KGaA, 2015.
5. I. Azzouz, K. Bachami, MEMS devices for miniaturized gas chromatography, IntechOpen. Chapter 7, 145-169 (2018).
6. Y. Saito, I. Ueta, Miniaturization of the development of high-performance separation systems, *Chromatographia*, **38**, 85-94 (2017).
7. N.L. Sanders, S. Kothari, G. Huang, G. Salazar, R.G. Cooks, Detection of explosives as negative ions directly from surfaces using a miniature mass spectrometer, *Anal. Chem.*, **82**, 12, 5313-5316 (2010).
8. E.M. McBride, P.M. Mach, E.S. Dhumakupt, S. Dowling, D.O. Carmay, P.S. Demond, G. Rizzo, N.E. Manicke, Paper spray ionization: Applications and perspectives, *Trends in Anal. Chem.*, **118**, 722-730 (2019).
9. Z. Quyang, R.G. Cooks, Miniature mass spectrometer. *Annu. Rev. Anal. Chem.*, 2:187-214 (2009).



10. D. Snyder, C. Pulliam, Z. Quyang, R. Cooks, Miniature and fieldable mass spectrometers, *Anal. Chem.*, **88** (1) 2-29 (2016).
11. S.E. Hamilton, F. Mattrey, X. Bu, D. Murray, B. McCullough, C.J. Welch, Use of miniature mass spectrometer to support pharmaceutical process chemistry. *Organic Process Research&Development.*, **18**, 103-108 (2014).
12. M.A. Makinen, O. Anttalainen and M.E.T. Sillanpaa: Ion Mobility Spectrometry and its applications in detection of chemical warfare agents, *Anal. Chem*, **82**, 9594-9600 (2010).
13. R. Cumeras, E. Figueras, C.E. Davis, J.I. Baumbach and Gracia: Review on ion mobility spectrometry, Part I: Current instrumentation., *Analyst*, **140**, 1376-1390 (2015). Part II: Hyphenated methods and effects of experimental parameters, *Analyst*, **140**, 1391-1410 (2015).
14. M. Grabka, E. Budzyńska, Z. Witkiewicz, J. Puton, K. Jasek, Portable gas chromatographs joint with ion mobility spectrometers for analysis of environmental pollutants. *ABiD*, **22**, 107-116 (2017).
15. X. Zheng, R. Wojcik, X. Zhang, Y.M. Ibrahim, K.E. Burnum-Johnson, D.J. Orton, M.E. Monroe, R. J. Moore, R.D. Smith, E.S. Baker, Coupling Front-End Separations, Ion Mobility Spectrometry, and Mass Spectrometry For Enhanced Multidimensional Biological and Environmental Analyses, *Annu. Rev. Anal. Chem.*, **10**, 71-92 (2017).
16. R.A. Miller, G.A. Eiceman, E.G. Nazarov, A micromachined field asymmetric ion mobility spectrometer, *Int. J. Ion Mobil. Spectrom.*, **5**, 118-134 (2002).
17. J.N. Smith, R.J. Noll, R.G. Cooks, Facility monitoring of chemical warfare agent simulants in air using an automated, field-deployable, miniature mass spectrometer. *Rapid Commun. Mass Spectrom.*, **25**, 1437-1444 (2011).
18. D. Snyder, P.S. Demond, L.J. Szalwinski, E.S. Dhummakupt, E.M. McBride, R.G. Cooks, T. Glaros, P.M. Mach, Two-dimensional MS/MS scans for a linear ion trap mass analyzer: identification of V-series chemical warfare agents, *Int. J. Mass Spectrom.*, **444**, 116171-116179 (2019).
19. T. Urabe, K. Takahashi, M. Kitagawa, T. Sato, T. Kondo, S. Enomoto, M. Kidera M.Y. Seto: Development of portable mass spectrometer with electron resonance ion source for detection of chemical warfare agents in air. *Acta A Mol. Biomol. Spectrosc.*, **120**, 437-444 (2014).
20. J. McKenna, E.S. Dhummakupt, T. Connel, P.S Demond, D.B. Miller, K.M. Nilles, N.E. Manicke, T. Glaros: Detection of chemical warfare simulants and hydrolysis products in biological samples by paper spray mass spectrometry, *Analyst*, **142**, 1442-1451 (2017).
21. P.M Mach, E.S. Dhummakupt, D.O. Carmany, E.M. McBride, M.W. Busch, P.S. Demond, G.M. Rizzo, D.E. Hollinshead, T. Glaros, On-substrate derivatization for detection of highly volatile G-series chemical warfare agents via paper spray mass spectrometry, *Rapid Comm. Mass Spectrom.*, **32**, 1979-1983 (2018).

22. J.I. Baumbach, S. Hundeloh, A. Teepe, M. Teepe, S. Sielemann, *Int. J. Ion Mobil. Spectrom.*, 6, 57-65 (2003).
23. W.E. Steiner, C.S. Harden, F.Hong, S.J. Klopsch, H.H. Hill, V.M. McHugh, Detection of Aqueous Phase Chemical Warfare Agent Degradation Products by Negative Mode Ion Mobility Time-of-Flight Mass Spectrometry, *J. Am. Soc. Mass Spectrom.*, 17, 241-245 (2006).
24. B.M. Kolakowski, P.A. D'Agostino, C. Chenier, Z. Mester, Analysis of Chemical Warfare Agents in Food Products by Atmospheric Pressure Ionization-High Field Asymmetric Waveform Ion Mobility Spectrometry-Mass Spectrometry, *Anal. Chem.*, 79, 8257-8265 (2007).
25. S. Yamaguchi, R. Asada, S. Kishi, R. Sekioka, N. Kitagawa, K. Tokita, S. Yamamoto, Y. Seto, Detection performance of a portable ion mobility spectrometer with ⁶³Ni radioactive ionization for chemical warfare agents, *Forensic Toxic.*, 28, 84-95 (2010).
26. S. Kishi, R. Sekioka, M. Sodeyama, M. Shiga, Y. Seto, Evaluation of detection performance of portable aspiration-type ion mobility spectrometer with seven detection cells for chemical warfare agents, *Bunseki Kagaku*, 59, 65-76 (2010).
27. T. Satoh, S. Kishi, H. Nagashima, M. Tachikawa, M. Kanamori-Kataoka, T. Nakagawa, N. Kitagawa, K. Tokita, S. Yamamoto, Y. Seto, Ion mobility spectrometric analysis of vapours chemical warfare agents by the instrument with corona discharge ionization ammonia dopant ambient temperature operation, *Anal. Chim. Acta*, 865, 39-52 (2015).
28. I.A. Buryakow, Express analysis of explosives, chemical warfare agents and drugs with multicapillary column gas chromatography and ion mobility increment spectrometry, *J. Chromatogr. B*, 800, 75-82 (2004).
29. N. Krylova, E. Krylov, G.A. Eiceman, J.A. Stone, Effect of Moisture on the Field Dependence of Mobility for Gas-Phase Ions of Organophosphorus Compounds at Atmospheric Pressure with Field Asymmetric Ion Mobility Spectrometry, *J. Phys. Chem A*, 107, 3648-3654 (2003).
30. M.D. Krebs, A.M. Zapata, E.G. Nazarov, R.A. Miller, I.S. Costa, A.L. Sonenshein, C.E. Davis, Detection of biological and chemical agents using differential mobility spectrometry technology, *IEEE Sensors J.*, 5(40), 696-703 (2005).
31. P.Rearden, P.B. Harrington, Rapid screening of precursor and degradation products of chemical warfare agents in soil by SPME ion mobility spectrometry, *Anal. Chem. Acta*, 545, 13-20 (2005).
32. Å. Fällman, L. Rittfeldt, Detection of chemical warfare agents in water by high temperature solid phase microextraction, *Ion Mob. Spectrom.*, 4, 85-87 (2001).



33. S. Zimmermann, S. Barth, W.K.M. Baether, J. Ringer, Miniaturized low-cost ion mobility spectrometer for fast detection of chemical warfare agents, *Anal. Chem.*, **80**, 6671-6676 (2008).
34. J. Puton, J. Namieśnik, Ion mobility spectrometry: current status and application for chemical warfare agents detection, *Trends in Anal. Chem.*, **85**, 10-20 (2016).
35. B.M. Kolakowski, Z. Mester, A review of applications of high-field asymmetric waveform ion mobility spectrometry (FAIMS) and differential mobility spectrometry (DMS), *Analyst*, **132**, 842-864 (2007).
36. P.R. Lewis, R.P. Manginell, D.R. Adkins, R.J. Kottenstette, D.R. Wheeler, S.S. Sokolowski, D.E. Trudell, J.E. Byrnes, M. Okandan, J.M. Bauer, R.G. Manley, G.C. Frye-Mason, Recent advancements in the gas-phase micro-chem-lab, *IEEE Sens. J.*, **6**, 784-795 (2006).
37. E. Budzynska, M. Grabka, Z. Witkiewicz, J. Puton, K. Jasek, Mobile GC-MS devices, *ABiD*, **22**, 117-124 (2017)
38. J.A. Contreras, J.A. Murray, S.E. Tolley, J.L. Oliphant, H.D. Tolley, S.A. Lammert, E.D. Lee, D.W. Later, M.L. Lee, Hand-portable gas chromatograph-toroidal ion trap mass spectrometer for detection of hazardous compounds, *J. Am. Soc. Mass Spectrom.*, **19**, 1425-1434 (2008).
39. H. Sekiguchi, K. Matsushita, S. Yamashiro, Y. Sano, T. Okuda, A. Sato, On-site determination of nerve and mustard gases using a field-portable gas chromatograph-mass spectrometer, *Forensic Toxicol.*, **24**, 17-22 (2006).
40. P.E. Leary, B. W. Kammrath, K. J. Lattman, G. L. Beals, Deploying portable gas chromatography-mass spectrometry to military users for the identification of toxic chemical agents in theatre, *Appl. Spectrosc.*, **73**, 841-858 (2019).
41. A. Harvey, Detection and identification of chemical warfare agents and explosives in complex matrices, University of York, March 2019.
42. P. Barran, B. Ruotolo, Ion mobility mass spectrometry, *Analyst*, **140**, 6772-6774 (2015).
43. M.J. Manard, R. Trainham, S. Weeks, S.L. Coy, E.V. Krylow, E.G. Nazarov, Differential mobility spectrometry/mass spectrometry: The design of a new mass spectrometer for real-time chemical analysis in the field, *Int. J. Mass Spectrom.*, **295**, 138-144 (2010).
44. R. P. Erickson, A. Tripathi, W.M. Maswadeh, A.P. Snyder, P.A. Smith, Closed tube sample introduction for gas chromatography-ion mobility spectrometry analysis of water contaminated with a chemical warfare agent surrogate compound, *Anal. Chim. Acta*, **556**, 455-461 (2006).

45. S. Hajjaligol, S. Ghorashi, A.H. Alinoori, A. Torabpour, M. Azimi, Thermal solid sample introduction-fast gas chromatography-low flow ion mobility spectrometry as a field screening detection system, *J. Chromatogr. A*, 1268, 123-129 (2012).
46. S.A. Lammert, A.A. Rockwood, M. Wang, M. Lee, E.D. Lee, S.E. Tolley, J.R. Oliphant, J.L. Jones, R.W. Waite, Miniature toroidal radio frequency ion trap mass analyzer, *J. Am. Soc. Mass Spectrom.*, 17, 916-922 (2006).
47. Z. Ouyang, R.J. Noll, R.G. Cooks, Miniature ion trap mass spectrometers, *Anal. Chem.*, 81, 2421-2425 (2009).
48. D.T. Snyder, C.J. Pulliam, Z. Oujang, R.G. Cooks, Miniature and fieldable mass spectrometers: recent advances, *Anal. Chem.*, 88, 2-29 (2016).
49. A.L. Makas, M.L. Troshkov, Field gas chromatography-mass spectrometry for fast analysis, *J. Chrom. B*, 800, 55-61 (2004.)
50. B.A. Eckenrode, Environmental and forensic application of field-portable GC-MS: an overview, *J. Am. Soc. Mass Spectrom.*, 12, 683-693 (2001).
51. P.A. Smith, C.J. Lepage, M. Lukacs, N. Martin, A. Shufutinsky, P.B. Savage, Field-portable gas chromatography with transmission quadrupole and cylindrical ion trap mass spectrometric detection: chromatographic retention index data and ion/molecule interactions for chemical warfare agent identification, *Int. J. Mass Spectrom.*, 295, 113-118 (2010).
52. C. Kwan, A.P. Snyder, R.P. Erickson, P.A. Smith, W.M. Maswadeh, B. Ayhan, J.L. Jensen, J.O. Jensen, A. Tripathi, Chemical agent detection using GC-IMS: a comparative study, *IEEE Sens. J.*, 10, 451-460 (2010).
53. A. Qualley, G.T. Hughes, H. Rubinstein, Data quality improvement for field-portable gas chromatography-mass spectrometry through the use of isotopic analogues for in-situ calibration, *Environ. Chem.*, 17, 28-38 (2020).
54. Y. Ohru, T. Nagoya, N. Kurimata, M. Sodeyama, Y. Seto, Identification of V-type nerve agents in vapor samples using a field-portable capillary gas chromatography/membrane-interfaced electron ionization quadrupole mass spectrometry instrument with Tri-Bed concentrator and fluoridating conversion tube, *J. Mass Spectrom.*, 52, 472-479 (2017).
55. R.V. Mustacich, Detection of chemical warfare agents by transportable GC/MS, Application note, Agilent Technologies 5990-6396 EN, 2010.
56. P.A. Smith, J. Lepage, G.R. Savage, Use of handportable gas chromatograph-toroidal ion trap mass spectrometer for self-chemical ionization identification of degradation products related to O-ethyl-S-(2-diisopropylaminoethyl) methyl phosphonothioate (VX), *Anal. Chim. Acta*, 690, 215-220 (2011).
57. J. Krykorkowa, T. Capoun: The equipment of Czech firefighters for the detection and field analyses of chemical warfare agents, *Toxics*, 2, 247-257 (2014).

58. E. Aguilera-Herrador, S. Cardenas, V. Ruzsanyi, S. Sielemann, M. Valcarcel, Evaluation of a new miniaturized ion mobility spectrometer and its coupling to fast gas chromatography multi-capillary columns, *J. Chromatogr. A*, 1214, 143-150 (2008).
59. J.I Baumbach, S. Sielemann, Pilzecker, Coupling of multi-capillary columns with two different types of ion mobility spectrometer, *Int. J. Ion Mobil. Spectrom.*, 402, 489-498 (2012).
60. H. Borsdorf, T. Mayer, Response of halogenated compounds in ion mobility spectrometry depending on their structural features, *Talanta*, 83, 815-822 (2011).
61. A. Bunkowski, Software tool for coupling chromatographic total ion current dependencies of GC/MSD and MCC/IMS, *Int. J. Ion Mobil. Spectrom.*, 13, 169-175 (2010).
62. B. Bodeker, J.I Baumbach, Analytical description of IMS signals, *Int. J. Ion Mobil. Spectrom.*, 12, 103-108 (2009).
63. J. Xu, B.W. William, Monte Carlo simulation of ion transport in ion mobility spectrometry, *Int. J. Ion Mobil. Spectrom.*, 11, 13-17 (2008).
64. A. Scheineman, S. Sieleman, J. Walter, T. Doll, Evaluation strategies for coupled GC-IMS measurement including the systematic use of parametrized ANN training data, *Open J. Appl. Sci.*, 2, 257-266 (2012).
65. N. Makarotseva, A. Seiman, M. Vaher, M. Kaljurand, Analysis of the degradation products of chemical warfare agents using a portable capillary electrophoresis instrument with various sample injections devices, *Procedia Chem.*, 2, 20-25 (2010).