

ON DYNAMICS OF ELASTIC NETWORKS WITH RIGID JUNCTIONS WITHIN NONLINEAR MICRO-POLAR ELASTICITY

Victor A. Eremeyev^{1,2,3,} & Emanuele Reccia¹*

¹*Department of Civil and Environmental Engineering and Architecture (DICAAR), University of Cagliari, Via Marengo, 2, 09123 Cagliari, Italy*

²*WILiŚ, Gdańsk University of Technology, Gdańsk, Poland*

³*Don State Technical University, Rostov on Don, Russia*

*Address all correspondence to: Victor A. Eremeyev, Department of Civil and Environmental Engineering and Architecture (DICAAR), University of Cagliari, Via Marengo, 2, 09123 Cagliari, Italy, E-mail: victor.eremeev@unica.it

Within the nonlinear micropolar elasticity we discuss effective dynamic (kinetic) properties of elastic networks with rigid joints. The model of a hyperelastic micropolar continuum is based on two constitutive relations, i.e., static and kinetic ones. They introduce a strain energy density and a kinetic energy density, respectively. Here we consider a three-dimensional elastic network made of three families of elastic fibers connected through massive rigid joints. Effective elastic properties are inherited from the geometry and material properties of the fibers, whereas the kinetic (inertia) properties are determined by the both fibers and joints. Formulae for microinertia tensors are given.

KEY WORDS: *elastic network, rigid junction, micropolar elasticity, dynamics, homogenization, effective properties*

1. INTRODUCTION

The model of micropolar solids was presented in detail in centurial book by Cosserat brothers (Cosserat and Cosserat, 1909). Initially proposed in their theory of elasticity in 1896 (Cosserat and Cosserat, 1896), the model relies on a continuum that could be treated as a set of material particles that possess independent translational and rotational degrees of freedom, as in rigid body dynamics. As a result, we have stresses and couple stresses as static counterparts of translations and rotations. The Cosserat model was discussed by several authors, among others, Eringen (1999), Nowacki (1986), and Maugin and Metrikine (2010); in Eremeyev et al. (2013) a complete overview of foundations of the theory and many solutions were presented.

Since several materials used in civil and mechanical engineering applications exhibit an internal microstructure, nowadays, the growing interest in micropolar model relates to the possibility of a proper description of their complex inner microstructure, when rotational interactions of material particles play an important role. Among such materials, it is worth mentioning: granular media—including masonries (Baraldi et al., 2015; de Bellis and Addessi, 2011; Pau and Trovalusci, 2012; Reccia et al., 2018b; Shi et al., 2021); some classes of composites (Addessi et al., 2013, 2016; Leonetti et al., 2018; Pingaro et al., 2019) like random (Reccia et al., 2018a; Trovalusci et al., 2017, 2014, 2015) and regular particles composite (Colatosti et al., 2022; Fantuzzi et al., 2019, 2020); nanotubes (Izadi et al., 2021a,b); and beam-lattice materials (Berkache et al., 2022; Fleck et al., 2010) including foams and porous media (Lakes, 1987, 1986). For example, considering a beam-lattice material as an effective medium it seems quite natural that this medium has to inherit some beam properties, such as sensitivity to applied surface and volumetric couples.

In this work, attention is focused on 3D elastic networks with rigid connections. This typology of material belongs to beam-lattice structures, which find several applications in many engineering areas (Pan et al., 2020; Phani and Hussein, 2017). Periodic networks of interconnected beams or rods, both in two or three dimensions, may have interesting mechanical properties related to their microstructure, such as a higher performance in term of weight/stiffness, in acoustic and thermal responses, as well as in the capacity of energy absorption, and greater deformation capacity before fracture/collapse. Moreover, these types of microstructured material may be found at all scales, from nano- and microscales, up to macroscale. These aspects make their study a very topical issue, their application being suitable in several engineering areas (dell’Isola et al., 2015; Lakes, 2020). In particular, here a three-dimensional network of orthogonal deformable flexible fibers connected together by rigid massive joints, such that they remain orthogonal during deformations, is studied. This kind of material can be found in common applications such as fishnets or metal fences, and it can be considered as a typical example of a metamaterial exhibiting peculiar mechanical properties related to its internal structure. For such material, the adoption of the micropolar model is crucial, thanks to the possibility of properly describing finite deformations of the fibers by means of two independent kinematic variables, translations and rotations (Eremeyev, 2019). A discrete model is adopted where fibers are therefore modeled by the adoption of the Cosserat curve (Altenbach et al., 2013). At macroscale, the material is modeled as an equivalent micropolar medium (Eremeyev, 2018).

The paper is organized as follows. First, in Section 2 we briefly recall the governing equations of three- and one-dimensional media. Within the micropolar approach we have two kinematical descriptors, that are the fields of translations and rotations. Particular attention is paid to the kinetic constitutive relations, i.e., to the form of a kinetic energy function. We define a kinetic energy density as a positive quadratic form dependent on linear and angular velocities. For comparison, we also consider rigid body motions and the form of kinetic energy for a rigid body. In Section 3 we introduce a beam-lattice network with rigid massive joints. Here we formulate a semidiscrete model of the network considering coupled motion of beams and rigid joints. Using a linear approximation as in Eremeyev (2019), we derive a discrete model of the network. Within this model, we restrict ourselves to translations and rotations given in a finite set of points related to the centers of mass of the joints. Comparing the discrete model with a similar discrete approximation of a three-dimensional (3D) micropolar continuum, in Section 4 we introduce the notion of the equivalent model. We call two models, i.e., of a network and of a 3D medium, *equivalent* if their discrete counterparts have the same form. As a result, we can identify the 3D kinetic constitutive relations through inertia properties of the beams of the joints.

2. GOVERNING EQUATIONS OF MICROPOLAR MEDIA

Let us briefly introduce the basic equations of the micropolar mechanics considering both three-dimensional (3D) and one-dimensional (1D) solids as well as rigid body dynamics.

2.1 Cosserat (Micropolar) Continuum

Let \mathcal{B} be an elastic micropolar solid body. A deformation of \mathcal{B} can be considered as an invertible mapping from a reference placement κ into a current placement $\chi(t)$, where t is time. For any point x of \mathcal{B} we introduce its position vectors \mathbf{X} and \mathbf{x} and triples of unit orthogonal vectors called directors $\{\mathbf{D}_k\}$ and $\{\mathbf{d}_k\}$; $k = 1, 2, 3$, defined in κ and χ , respectively. In other words, the position vector and directors play a role of kinematical descriptors in the micropolar elasticity, see Eremeyev et al. (2013) and Eringen (1999). As a result, a deformation of \mathcal{B} is given by

$$\mathbf{x} = \mathbf{x}(\mathbf{X}, t), \quad \mathbf{Q} = \mathbf{Q}(\mathbf{X}, t), \quad (1)$$

where $\mathbf{Q} = \mathbf{D}_k \otimes \mathbf{d}_k$ is an orthogonal tensor of microrotation and \otimes is the dyadic product.

Considering hyperelastic materials we introduce a strain energy density W as a function of \mathbf{x} and \mathbf{Q} and their first gradients

$$W = W(\mathbf{x}, \mathbf{Q}, \nabla \mathbf{x}, \nabla \mathbf{Q}), \quad (2)$$

where ∇ is the three-dimensional nabla operator as defined in Simmonds (1994) and Eremeyev et al. (2018). Applying to Eq. (2) the principle of material frame indifference by Truesdell and Noll (2004), we get W as a function of two strain Lagrangian strain measures \mathbf{E} and \mathbf{K} ,

$$W = W(\mathbf{E}, \mathbf{K}), \quad (3)$$

where

$$\mathbf{E} = \mathbf{F} \cdot \mathbf{Q}^T, \quad \mathbf{F} = \nabla \mathbf{x}, \quad \mathbf{K} \times \mathbf{I} = -(\nabla \mathbf{Q}) \cdot \mathbf{Q}^T,$$

see Pietraszkiewicz and Eremeyev (2009) for more details. Hereinafter “ \cdot ” and “ \times ” denote the dot and cross products, respectively; \mathbf{F} is the deformation gradient; \mathbf{I} is the 3D unit tensor; and superscript T stands for the transpose of a second-order tensor.

In order to complete the constitutive description of the micropolar medium we introduce a kinetic energy density K as a positive quadratic form of linear \mathbf{v} and angular $\boldsymbol{\omega}$ velocities,

$$K = \frac{1}{2} \rho \mathbf{v} \cdot \mathbf{v} + \frac{1}{2} \boldsymbol{\omega} \cdot \mathbf{j} \cdot \boldsymbol{\omega} + \boldsymbol{\omega} \cdot \mathbf{j}_1 \cdot \mathbf{v}, \quad (4)$$

$$\mathbf{v} = \dot{\mathbf{x}}, \quad \boldsymbol{\omega} = -\frac{1}{2} (\dot{\mathbf{Q}} \cdot \mathbf{Q}^T)_{\times}, \quad (5)$$

where ρ is a referential mass density, the over-dot denotes the derivative with respect to t , and \mathbf{j} and \mathbf{j}_1 are tensors of microinertia. In addition we introduce the Gibbsian cross or the vectorial invariant of a second-order tensor as an operation which maps a tensor into a vector. For a dyad of two vectors it is defined as follows,

$$(\mathbf{a} \otimes \mathbf{b})_{\times} = \mathbf{a} \times \mathbf{b},$$

and can be extended to any second-order tensor.

Let us note that the form of kinetic energy, i.e. the form of so-called kinetic constitutive relations, plays an essential role in micropolar dynamics (Eringen, 1999; Eringen and Kafadar, 1976). It is worth mentioning here a similar situation in the case of thin-walled structures, where rotatory inertia may significantly change oscillations and wave propagation, see, e.g., Mindlin (1951) and Pietraszkiewicz (2011).

The Lagrangian equation of motion takes the form

$$\nabla \cdot \mathbf{T} + \rho \mathbf{f} = \rho \dot{\mathbf{v}} + (\boldsymbol{\omega} \cdot \mathbf{j}_1)', \quad \mathbf{T} = \frac{\partial W}{\partial \mathbf{E}} \cdot \mathbf{Q}^T, \quad (6)$$

$$\nabla \cdot \mathbf{M} + (\mathbf{F}^T \cdot \mathbf{T})_{\times} + \rho \mathbf{c} = \mathbf{v} \times \mathbf{j}_1 \cdot \boldsymbol{\omega} + (\mathbf{j}_1 \cdot \mathbf{v})' + (\mathbf{j} \cdot \boldsymbol{\omega})', \quad \mathbf{M} = \frac{\partial W}{\partial \mathbf{K}} \cdot \mathbf{Q}^T, \quad (7)$$

where \mathbf{T} and \mathbf{M} are the first Piola–Kirchhoff stress and couple stress tensors, respectively; \mathbf{f} and \mathbf{c} are the mass force and couple vectors.

2.2 Cosserat Curve

The Cosserat curve model constitutes a particular case of micropolar media; see Antman (2005), Rubin (2000), and Eremeyev et al. (2013). Indeed, this model could be treated as 1D micropolar continuum embedded into the 3D Euclidean space. We again consider deformations of a Cosserat curve \mathcal{C} as a mapping from a reference placement $\kappa_{\mathcal{C}}$ into a current placement $\chi_{\mathcal{C}}(t)$. The position and orientation of a material particle z of \mathcal{C} are determined through its position vector and directors defined in both placements. In particular, in $\kappa_{\mathcal{C}}$ we define a position vector $\mathbf{X}_{\mathcal{C}}(s)$ and directors $\mathbf{D}_k(s)$ given as vector-valued functions of the referential arc-length parameter s . For $\chi_{\mathcal{C}}$, z has a position vector $\mathbf{x}_{\mathcal{C}}(s, t)$ and directors $\mathbf{d}_k(s, t)$ given as a functions of s and t . So the kinematics of \mathcal{C} is defined through the position vector $\mathbf{x}_{\mathcal{C}}(s, t)$ and the microrotation tensor $\mathbf{Q}_{\mathcal{C}}(s, t)$.

We introduce a strain energy density $W_{\mathcal{C}}$ defined per unit length in the reference placement as a function of $\mathbf{x}_{\mathcal{C}}$ and $\mathbf{Q}_{\mathcal{C}}$ and their derivatives with respect to s ,

$$W_{\mathcal{C}} = W_{\mathcal{C}}(\mathbf{x}_{\mathcal{C}}, \mathbf{Q}_{\mathcal{C}}, \mathbf{x}'_{\mathcal{C}}, \mathbf{Q}'_{\mathcal{C}}), \quad (8)$$



where the prime stands for the derivative with respect to s . Using the material frame-indifference principle we transform Eq. (8) into the form (Altenbach et al., 2013; Bîrsan et al., 2012)

$$W_C = W_C(\mathbf{e}, \mathbf{k}), \quad \mathbf{e} = \mathbf{x}'_C \cdot \mathbf{Q}_C^T, \quad \mathbf{k} = -\frac{1}{2}(\dot{\mathbf{Q}}_C \cdot \mathbf{Q}_C^T)_\times, \quad (9)$$

with two vector-valued Lagrangian strain measures.

Within the Cosserat curve approach we introduce a linear \mathbf{v}_C and angular $\boldsymbol{\omega}_C$ velocities given by

$$\mathbf{v}_C = \dot{\mathbf{x}}_C, \quad \boldsymbol{\omega}_C = -\frac{1}{2}(\dot{\mathbf{Q}}_C \cdot \mathbf{Q}_C^T)_\times, \quad (10)$$

so the kinetic energy density defined per unit length in κ_C is given by

$$K_C = \frac{1}{2}\rho_C \mathbf{v}_C \cdot \mathbf{v}_C + \frac{1}{2}\boldsymbol{\omega}_C \cdot \mathbf{j}_C \cdot \boldsymbol{\omega}_C + \boldsymbol{\omega}_C \cdot \mathbf{j}_{C1} \cdot \mathbf{v}_C, \quad (11)$$

where ρ_C is a referential linear mass density; \mathbf{j}_C and \mathbf{j}_{C1} are tensors of inertia.

Lagrangian equations of motion have the form

$$\mathbf{T}'_C + \rho_C \mathbf{f}_C = \rho_C \dot{\mathbf{v}}_C + (\boldsymbol{\omega}_C \cdot \mathbf{j}_{C1})', \quad \mathbf{T}_C = \frac{\partial W_C}{\partial \mathbf{e}} \cdot \mathbf{Q}_C^T, \quad (12)$$

$$\mathbf{M}'_C + \mathbf{x}'_C \times \mathbf{T}_C + \rho_C \mathbf{c}_C = \mathbf{v}_C \times \mathbf{j}_{C1} \cdot \boldsymbol{\omega}_C + (\mathbf{v}_C \cdot \mathbf{j}_{C1})' + (\mathbf{j}_C \cdot \boldsymbol{\omega}_C)', \quad \mathbf{M}_C = \frac{\partial W_C}{\partial \mathbf{k}} \cdot \mathbf{Q}_C^T, \quad (13)$$

where \mathbf{T}_C and \mathbf{M}_C are the first Piola–Kirchhoff stress and couple stress vectors, respectively; \mathbf{f}_C and \mathbf{c}_C are the mass force and couple vectors introduced per unit mass in the reference placement. One can easily find similarities between these Eqs. (6) and (7). In what follows we assume that the center of mass of a cross section is chosen as a position of the Cosserat curve, so we have $\mathbf{j}_{C1} = 0$.

2.3 Rigid Body Dynamics

Finally, in order to describe a rigid joint motion let us briefly consider elements of rigid body dynamics. Let \mathcal{B} be a rigid body loaded by a net force \mathbf{N} and total torque \mathbf{L} . Following Lurie (2001) and Eremeyev et al. (2013) the kinematics of \mathcal{B} could be described as a translation of an arbitrary point O of \mathcal{B} called the pole and a rotation about O . Using this description we introduce position vectors of another point P of \mathcal{B} in reference κ_B and current χ_B placements as follows

$$\mathbf{X} = \mathbf{X}_0 + \boldsymbol{\xi}, \quad \mathbf{x}(t) = \mathbf{x}_0(t) + \boldsymbol{\eta}(t), \quad (14)$$

where \mathbf{X}_0 and \mathbf{x}_0 are position vectors of O , whereas $\boldsymbol{\xi}$ and $\boldsymbol{\eta}$ are vectors \overrightarrow{OP} directed from O to P in κ_B and χ_B , respectively. The latter vectors are related to each other through a rotation tensor \mathbf{Q} , so

$$\boldsymbol{\eta}(t) = \mathbf{Q}(t) \cdot \boldsymbol{\xi}. \quad (15)$$

As a result, the displacement vector of P is given by

$$\mathbf{u}(t) \equiv \mathbf{x}(t) - \mathbf{X} = \mathbf{x}_0(t) - \mathbf{X}_0 + \mathbf{Q}(t) \cdot \boldsymbol{\xi} - \boldsymbol{\xi}. \quad (16)$$

From Eq. (16) we get the formulae for linear \mathbf{v} and angular $\boldsymbol{\omega}$ velocities,

$$\mathbf{v} \equiv \dot{\mathbf{u}} = \mathbf{v}_0 + \boldsymbol{\omega} \times \boldsymbol{\eta}, \quad \mathbf{v}_0 = \dot{\mathbf{x}}_0, \quad \boldsymbol{\omega} = -\frac{1}{2}(\dot{\mathbf{Q}} \cdot \mathbf{Q}^T)_\times, \quad (17)$$

where \mathbf{v}_0 is a velocity of the pole.



The kinetic energy of \mathcal{B} is given by

$$K_B = \frac{1}{2} \iiint_{v_B} \rho_B \mathbf{v} \cdot \mathbf{v} \, dv, \quad (18)$$

where ρ_B is a mass density of \mathcal{B} and v_B is a volume which \mathcal{B} occupies in χ_B . With Eq. (17) we have

$$\begin{aligned} K_B &= \frac{1}{2} \iiint_{v_B} \rho_B (\mathbf{v}_0 + \boldsymbol{\omega} \times \boldsymbol{\eta}) \cdot (\mathbf{v}_0 + \boldsymbol{\omega} \times \boldsymbol{\eta}) \, dv \\ &= \frac{1}{2} \iiint_{v_B} \rho_B \, dv \mathbf{v}_0 \cdot \mathbf{v}_0 - \frac{1}{2} \boldsymbol{\omega} \cdot \iiint_{v_B} \rho_B \boldsymbol{\eta} \times \mathbf{I} \times \boldsymbol{\eta} \, dv \cdot \boldsymbol{\omega} + \boldsymbol{\omega} \cdot \iiint_{v_B} \rho_B \mathbf{I} \times \boldsymbol{\eta} \, dv \cdot \mathbf{v}_0. \end{aligned} \quad (19)$$

Introducing the mass of \mathcal{B} and the tensors of inertia by the formulae

$$M_B = \iiint_{v_B} \rho_B \, dv, \quad \mathbf{J} = - \iiint_{v_B} \rho_B \boldsymbol{\eta} \times \mathbf{I} \times \boldsymbol{\eta} \, dv, \quad \mathbf{J}_1 = \iiint_{v_B} \rho_B \mathbf{I} \times \boldsymbol{\eta} \, dv, \quad (20)$$

we transform Eq. (19) into

$$K_B = \frac{1}{2} M_B \mathbf{v}_0 \cdot \mathbf{v}_0 + \frac{1}{2} \boldsymbol{\omega} \cdot \mathbf{J} \cdot \boldsymbol{\omega} + \boldsymbol{\omega} \cdot \mathbf{J}_1 \cdot \mathbf{v}_0. \quad (21)$$

In what follows we use the center of mass of \mathcal{B} as a pole, so $\mathbf{J}_1 = 0$. Using Eq. (15) we have

$$\mathbf{J} = \mathbf{q} \cdot \mathbf{J}_0 \cdot \mathbf{Q}^T, \quad \mathbf{J}_0 = \iiint_{V_B} \rho_B \boldsymbol{\xi} \times \mathbf{I} \times \boldsymbol{\xi} \, dV, \quad (22)$$

where \mathbf{J}_0 is the referential tensor of inertia and V_B is a domain of \mathcal{B} in κ_B .

Finally, the equations of motion of \mathcal{B} have the form

$$M_B \dot{\mathbf{v}}_0 = \mathbf{N}, \quad (\mathbf{J} \cdot \boldsymbol{\omega})' = \mathbf{L}. \quad (23)$$

If we assume that the previously considered 3D and 1D solids are rigid, we immediately come from Eqs. (6) and (7) or Eqs. (12) and (13) to Eq. (23). In fact, for the model presented above we face forces and couples as primary dynamic measures. Moreover, one can see that, similar to rigid body dynamics, tensors of inertia are presented in all micropolar media, in general.

3. ELASTIC NETWORKS

Let us consider a regular elastic network made of three families of flexible fibers connected to each other through rigid joints as shown in Fig. 1. For simplicity we assume that all fibers (links) have the same mechanical and geometrical properties. This includes forms of strain and kinetic energies W_C , K_C ; links length ℓ , ρ_C , \mathbf{j}_C , \mathbf{J}_0 , M_B , etc. We mark each joint through indices i, j , and k ; $i = 1, \dots, m$, $j = 1, \dots, n$, and $k = 1, \dots, l$. For example, a center of mass of the i, j, k th joint we denote as $O_{i,j,k}$; see Fig. 2.

Lagrangian equations of motion of the considered network consist of partial differential equations (PDEs) for elastic links and ordinary differential equations (ODEs) for joints. Following Eremeyev (2019) the latter system of



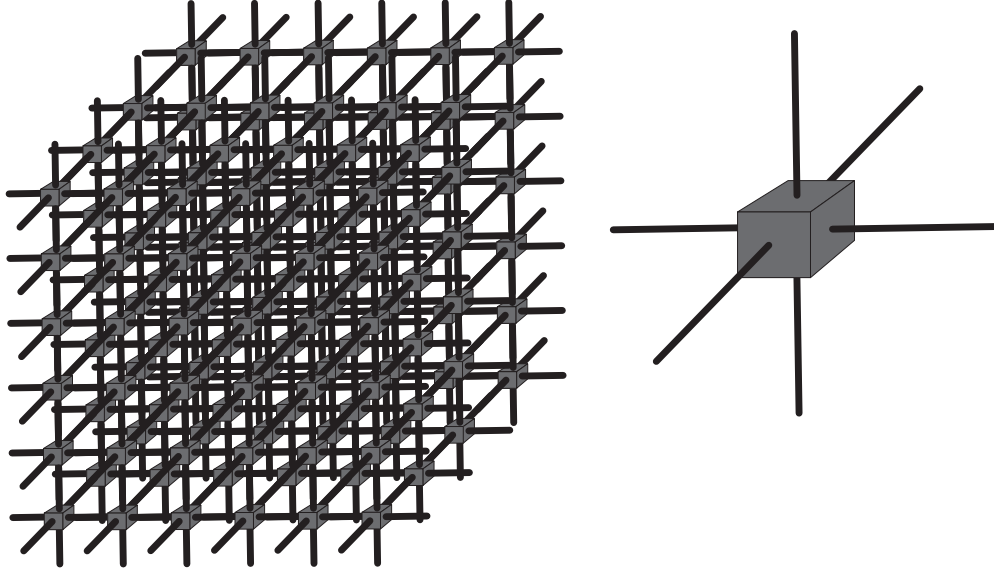

FIG. 1: Elastic network with rigid joints and one “elementary cell” of it

equations takes the form

$$\mathbf{T}'_{C1,1} + \rho_C \mathbf{f}_{C1} = \rho_C \dot{\mathbf{v}}_{C1}, \quad s_1 \in (s_1^i, s_1^{i+1}), \quad i = 1, \dots, m-1. \quad (24)$$

$$\mathbf{M}'_{C1,1} + \mathbf{x}'_{C1,1} \times \mathbf{T}_{C1} + \rho_C \mathbf{c}_{C1} = (\mathbf{j}_{C1} \cdot \boldsymbol{\omega}_{C1})'. \quad (25)$$

$$\mathbf{T}'_{C2,2} + \rho_C \mathbf{f}_{C2} = \rho_C \dot{\mathbf{v}}_{C2}, \quad s_2 \in (s_2^j, s_2^{j+1}), \quad j = 1, \dots, n-1. \quad (26)$$

$$\mathbf{M}'_{C2,2} + \mathbf{x}'_{C2,2} \times \mathbf{T}_{C2} + \rho_C \mathbf{c}_{C2} = (\mathbf{j}_{C2} \cdot \boldsymbol{\omega}_{C2})'. \quad (27)$$

$$\mathbf{T}'_{C3,3} + \rho_C \mathbf{f}_{C3} = \rho_C \dot{\mathbf{v}}_{C3}, \quad s_3 \in (s_3^k, s_3^{k+1}), \quad k = 1, \dots, l-1. \quad (28)$$

$$\mathbf{M}'_{C3,3} + \mathbf{x}'_{C3,3} \times \mathbf{T}_{C3} + \rho_C \mathbf{c}_{C3} = (\mathbf{j}_{C3} \cdot \boldsymbol{\omega}_{C3})'. \quad (29)$$

$$M_B \dot{\mathbf{v}}_{i,j,k} = \mathbf{N}_{i,j,k}, \quad (\mathbf{J}_{i,j,k} \cdot \boldsymbol{\omega}_{i,j,k})' = \mathbf{L}_{i,j,k}. \quad (30)$$

Hereinafter we introduce a Cartesian coordinate system ($x = s_1, y = s_2, z = s_3$) and corresponding unit base vectors $\mathbf{i}_1, \mathbf{i}_2, \mathbf{i}_3$ in such a way that s_1 is the arc-length parameter of fibers aligned in the i th direction and \mathbf{i}_1 is the tangent vector to this fiber in the reference placement, respectively. Coordinates s_2 and s_3 are chosen similarly for fibers which constitute the second and third families of the network, respectively. In addition we use the notations

$$(\dots)'_{,1} = \frac{\partial}{\partial s_1}, \quad (\dots)'_{,2} = \frac{\partial}{\partial s_2}, \quad (\dots)'_{,3} = \frac{\partial}{\partial s_3}.$$

In Eqs. (24)–(30) $\mathbf{f}_{C1}, \mathbf{c}_{C1}, \mathbf{f}_{C2}, \mathbf{c}_{C2}, \mathbf{f}_{C3}, \mathbf{c}_{C3}, \mathbf{N}_{i,j,k}$, and $\mathbf{L}_{i,j,k}$ are corresponding forces and couples.

The cornerstone of the further description of network motions is kinematic compatibility conditions, which describes mutual deformations of fibers connected via joints. Let us consider a contact point P of a fiber perfectly connected to a joint. One can find that the linear velocity of P is given by the formula

$$\mathbf{v}_C = \mathbf{v}_O + \boldsymbol{\xi} \times \boldsymbol{\omega}_O, \quad (31)$$

whereas the angular velocity of P and O are equal:

$$\boldsymbol{\omega}_C = \boldsymbol{\omega}_O. \quad (32)$$



In Eq. (31) $\vec{\xi}$ is a vector \overrightarrow{OP} from the center of mass O to P . As the i, j, k th joint is connected to six fibers, we have six ξ -vectors which are denoted as

$$\xi_{i-,j,k}, \quad \xi_{i+,j,k}, \quad \xi_{i,j-,k}, \quad \xi_{i,j+,k}, \quad \xi_{i,j,k-}, \quad \xi_{i,j,k+},$$

see Fig. 2.

Dynamic compatibility conditions could be derived using the least action principle,

$$\delta\mathcal{H} = 0, \tag{33}$$

where \mathcal{H} is the action functional. It could be written in a standard way,

$$\mathcal{H} = \int_{t_1}^{t_2} (\mathcal{K}_N - \mathcal{W}_N) dt, \tag{34}$$

where \mathcal{K}_N and \mathcal{W}_N are kinetic and potential energies of the network given by the relations

$$\begin{aligned} \mathcal{K}_N = & \sum_{k=1}^l \sum_{j=1}^n \sum_{i=1}^{m-1} \int_{s_i^k}^{s_{i+1}^k} K_C(s_1) ds_1 + \sum_{k=1}^l \sum_{j=1}^{n-1} \sum_{i=1}^m \int_{s_2^j}^{s_2^{j+1}} K_C(s_2) ds_2 \\ & + \sum_{k=1}^{l-1} \sum_{j=1}^n \sum_{i=1}^m \int_{s_3^k}^{s_3^{k+1}} K_C(s_3) ds_3 + \sum_{k=1}^l \sum_{j=1}^n \sum_{i=1}^m K_B, \end{aligned} \tag{35}$$

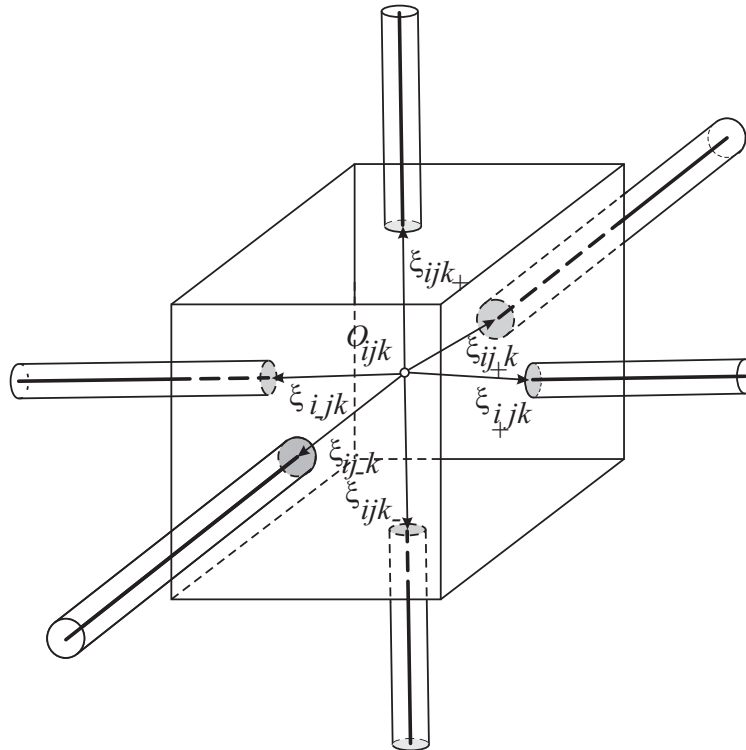

FIG. 2: Geometry in the vicinity of a i, j, k -joint

$$\begin{aligned} \mathcal{W}_N = & \sum_{k=1}^l \sum_{j=1}^n \sum_{i=1}^{m-1} \int_{s_1^i}^{s_1^{i+1}} W_C(s_1) ds_1 + \sum_{k=1}^l \sum_{j=1}^{n-1} \sum_{i=1}^m \int_{s_2^j}^{s_2^{j+1}} W_C(s_2) ds_2 \\ & + \sum_{k=1}^{l-1} \sum_{j=1}^n \sum_{i=1}^m \int_{s_3^k}^{s_3^{k+1}} W_C(s_3) ds_3. \end{aligned} \quad (36)$$

Obviously, joints do not contribute in the potential energy of the network whereas their contribution to the kinetic energy could be significant.

In Eq. (33) variations of kinematic descriptors also satisfy Eqs. (31) and (32):

$$\delta \mathbf{u}_C = \delta \mathbf{u}_O + \boldsymbol{\xi} \times \delta \boldsymbol{\psi}_O, \quad \delta \boldsymbol{\psi}_C = \delta \boldsymbol{\psi}_O, \quad (37)$$

where $\delta \mathbf{u}_C$, $\delta \mathbf{u}_O$, and $\delta \boldsymbol{\psi}_C$, $\delta \boldsymbol{\psi}_O$ are the virtual translations and vectors of virtual rotations; see Eremeyev et al. (2013).

Equations (24)–(30) constitute a semidiscrete model of a network. In order to introduce an effective homogenized medium we extend the approach by Eremeyev (2019) to the case of dynamics.

4. EQUIVALENT CONTINUUM MODEL OF A NETWORK AND ITS EFFECTIVE PROPERTIES

Considering the statics of an elastic network with rigid joints Eremeyev (2019) introduced an equivalent micropolar medium whose strain energy density inherited elastic properties of the network fibers. By an equivalent model we mean a continuum medium whose discretization coincides with discretization of the semidiscrete model. As a result, a strain energy density of the equivalent micropolar model has the form

$$W_E = \tilde{W}_C(\mathbf{i}_1 \cdot \mathbf{E} \cdot \mathbf{i}_1, \mathbf{i}_1 \cdot \mathbf{K} \cdot \mathbf{i}_1) + \tilde{W}_C(\mathbf{i}_2 \cdot \mathbf{E} \cdot \mathbf{i}_2, \mathbf{i}_2 \cdot \mathbf{K} \cdot \mathbf{i}_2) + \tilde{W}_C(\mathbf{i}_3 \cdot \mathbf{E} \cdot \mathbf{i}_3, \mathbf{i}_3 \cdot \mathbf{K} \cdot \mathbf{i}_3), \quad (38)$$

where \tilde{W}_C is a normalized strain energy of the Cosserat curve; see Eremeyev (2019) for more details.

Here we extend the same approach for derivation of an equivalent kinetic energy K_E . First, let us introduce the effective mass density ρ_E by the formula

$$\rho_E V = 3\rho_C \ell + M_B, \quad (39)$$

where V is the volume of the minimal rectangular cuboid which includes the elementary cell. It could be calculated as follows: $V = 3S_C \ell + V_B$, where S_C and V_B are the area of the fiber cross section and the volume of the joint, respectively. Then, we replace integrals in Eq. (35) using the trapezoidal rule as follows:

$$\begin{aligned} \int_{s_1^i}^{s_1^{i+1}} K_C(s_1) ds_1 &= \frac{\ell}{2} [K_C(s_1^i) + K_C(s_1^{i+1})], \\ \int_{s_2^j}^{s_2^{j+1}} K_C(s_2) ds_2 &= \frac{\ell}{2} [K_C(s_2^j) + K_C(s_2^{j+1})], \\ \int_{s_3^k}^{s_3^{k+1}} K_C(s_3) ds_3 &= \frac{\ell}{2} [K_C(s_3^k) + K_C(s_3^{k+1})]. \end{aligned}$$

As a result, \mathcal{K}_N becomes a function given at the ends of the fibers.

Let us now consider the kinetic energy density K_C at an end of a fiber. Using Eqs. (31) and (32) we come to the equation

$$K_C = \frac{1}{2} \rho_C [\mathbf{v}_O \cdot \mathbf{v}_O + 2\mathbf{v}_O \cdot (\boldsymbol{\xi} \times \mathbf{I}) \cdot \boldsymbol{\omega}_O - \boldsymbol{\omega}_O \cdot (\boldsymbol{\xi} \times \mathbf{I} \times \boldsymbol{\xi}) \cdot \boldsymbol{\omega}_O] + \frac{1}{2} \boldsymbol{\omega}_O \cdot \mathbf{j}_C \cdot \boldsymbol{\omega}_O. \quad (40)$$



As a result, the kinetic energy of the elementary cell has the form

$$VK_E = 3\ell\rho_C \left[\mathbf{v}_O \cdot \mathbf{v}_O + 2 \sum' \mathbf{v}_O \cdot (\boldsymbol{\xi}' \times \mathbf{I}) \cdot \boldsymbol{\omega}_O - \sum' \boldsymbol{\omega}_O \cdot (\boldsymbol{\xi}' \times \mathbf{I} \times \boldsymbol{\xi}') \cdot \boldsymbol{\omega}_O \right] + \boldsymbol{\omega}_O \cdot 3\ell\mathbf{j}_C \cdot \boldsymbol{\omega}_O + \frac{1}{2}M_B \mathbf{v}_O \cdot \mathbf{v}_O + \frac{1}{2}\boldsymbol{\omega}_O \cdot \mathbf{j}_C \cdot \boldsymbol{\omega}_O. \quad (41)$$

Here we use summation \sum' with respect to all connection points of the i, j, k th joint:

$$\sum'(\dots) = (\dots)|_{i-,j,k} + (\dots)|_{i+,j,k} + (\dots)|_{i,j-,k} + (\dots)|_{i,j+,k} + (\dots)|_{i,j,k-} + (\dots)|_{i,j,k+}.$$

Finally, the effective kinetic energy can be written in a more compact way,

$$K_E = \frac{1}{2}\rho_E \mathbf{v}_O \cdot \mathbf{v}_O + \mathbf{v}_O \cdot \mathbf{j}_{1E} \cdot \boldsymbol{\omega}_O + \frac{1}{2}\boldsymbol{\omega}_O \cdot \mathbf{j}_E \cdot \boldsymbol{\omega}_O, \quad (42)$$

where we have introduced two micro-inertia tensors:

$$V\mathbf{j}_E = \mathbf{J} + 3\ell\mathbf{j}_C - \sum' \frac{\rho_C \ell}{2} (\boldsymbol{\xi}' \times \mathbf{I} \times \boldsymbol{\xi}'), \quad V\mathbf{j}_{1E} = \frac{1}{2} \sum' (\boldsymbol{\xi}' \times \mathbf{I}). \quad (43)$$

If we neglect the inertia properties of the fibers, i.e., consider massive joints and light fibers, these formulae can be simplified,

$$V\mathbf{j}_E = \mathbf{J} - \sum' \frac{\rho_C \ell}{2} (\boldsymbol{\xi}' \times \mathbf{I} \times \boldsymbol{\xi}'), \quad V\mathbf{j}_{1E} = \frac{1}{2} \sum' (\boldsymbol{\xi}' \times \mathbf{I}), \quad (44)$$

or even as follows if we also neglect the mass of the fibers:

$$V\mathbf{j}_E = \mathbf{J}, \quad V\mathbf{j}_{1E} = 0. \quad (45)$$

One can see that mass and inertia properties of joints essentially affect effective kinetic energy density.

Equation (43) or their simplified counterparts Eqs. (44) and (45) can be extended for fibers of different properties and even for less regular networks when rigid joints connect to various numbers of fibers.

5. CONCLUSIONS

We have discussed kinetic constitutive equations for an elastic network from the point of view of micropolar elasticity. Here we restrict ourselves to elastic networks with rigid massive joints. Considering the network as a homogenized micropolar continuum we have shown that elastic properties are determined through the properties of network links, whereas dynamic properties, i.e., microinertia tensors, depend on both mass distribution along elastic links and joints. In particular, for massive joints microinertia tensors are almost entirely determined through inertia properties of joints. Let us note that joints can be nonsymmetric with respect to elastic links connections, which results in the appearance of two microinertia tensors in a kinetic energy density of the homogenized micropolar medium. This will result in dynamic coupling between translational and rotational degrees of freedom, in general. Moreover, this brings into the micropolar theory two microinertia tensors whereas usually they assume $\mathbf{j}_1 = 0$ and $\mathbf{j} = j\mathbf{I}$ with scalar measure of rotational inertia j , see; e.g., Eringen (1999). This case corresponds to symmetric material particles such as spheres. Dynamic properties introduced through two microinertia tensors can be taken into account considering material symmetry as in Eremeyev and Konopińska-Zmysłowska (2020); see also Vilchevskaya et al. (2022), where other references on microinertia tensors can be found. Formulae derived here for the microinertia tensors complete the description by Eremeyev (2019) of a network undergoing large deformations within micropolar elasticity. Further development of this research will be devoted to improving the assessment of the dynamic behavior of elastic networks with rigid junctions. With this purpose, the characteristics of wave propagation in media may be exploited. In particular, an effective correlation between the microstructure, and the way in which waves propagate in the medium, may be found. This relation may be very useful both to better understand the mechanical behavior of such materials, to improve both their design and modeling in order to achieve specific required properties.

ACKNOWLEDGMENT

The first author acknowledges the support by the Russian Science Foundation under Grant No. 22-49-08014.

REFERENCES

- Addessi, D., De Bellis, M.L., and Sacco, E., Micromechanical Analysis of Heterogeneous Materials Subjected to Overall Cosserat Strains, *Mech. Res. Commun.*, vol. **54**, pp. 27–34, 2013.
- Addessi, D., De Bellis, M.L., and Sacco, E., A Micromechanical Approach for the Cosserat Modeling of Composites, *Meccanica*, vol. **51**, no. 3, pp. 569–592, 2016.
- Altenbach, H., Bîrsan, M., and Eremeyev, V.A., *Cosserat-Type Rods*, Vienna: Springer, pp. 179–248, 2013.
- Antman, S.S., *Nonlinear Problems of Elasticity*, 2nd ed., New York: Springer Science Media, 2005.
- Baraldi, D., Cecchi, A., and Tralli, A., Continuous and Discrete Models for Masonry Like Material: A Critical Comparative Study, *Eur. J. Mech., A: Solids*, vol. **50**, pp. 39–58, 2015.
- Berkache, K., Phani, S., and Ganghoffer, J.F., Micropolar Effects on the Effective Elastic Properties and Elastic Fracture Toughness of Planar Lattices, *Eur. J. Mech. A: Solids*, p. 104489, 2022.
- Bîrsan, M., Altenbach, H., Sadowski, T., Eremeyev, V., and Pietras, D., Deformation Analysis of Functionally Graded Beams by the Direct Approach, *Compos. Part B: Eng.*, vol. **43**, no. 3, pp. 1315–1328, 2012.
- Colatosti, M., Fantuzzi, N., Trovalusci, P., and Masiani, R., New Insights on Homogenization for Hexagonal-Shaped Composites as Cosserat Continua, *Meccanica*, vol. **57**, pp. 885–904, 2022.
- Cosserat, E. and Cosserat, F., Sur la Théorie de l'Elasticité, *Ann. Toulouse*, vol. **10**, pp. 1–116, 1896.
- Cosserat, E. and Cosserat, F., *Théorie des Corps Déformables*, Paris: Herman et Fils, 1909.
- de Bellis, M.L. and Addessi, D., A Cosserat Based Multi-Scale Model for Masonry Structures, *Int. J. Multiscale Comput. Eng.*, vol. **9**, no. 5, pp. 543–563, 2011.
- dell'Isola, F., Steigmann, D., and Della Corte, A., Synthesis of Fibrous Complex Structures: Designing Microstructure to Deliver Targeted Macroscale Response, *Appl. Mech. Rev.*, vol. **67**, no. 6, p. 060804, 2015.
- Eremeyev, V.A., On Characterization of an Elastic Network within the Six-Parameter Shell Theory, *Shell Structures: Theory and Applications—Proc. of the 11th Int. Conf. on Shell Structures: Theory and Applications, SSTA 2017*, Gdansk, Poland, vol. **4**, pp. 81–84, 2018.
- Eremeyev, V.A., Two- and Three-Dimensional Elastic Networks with Rigid Junctions: Modeling within the Theory of Micropolar Shells and Solids, *Acta Mech.*, vol. **230**, no. 11, pp. 3875–3887, 2019.
- Eremeyev, V.A., Cloud, M.J., and Lebedev, L.P., *Applications of Tensor Analysis in Continuum Mechanics*, Hackensack, NJ: World Scientific, 2018.
- Eremeyev, V.A. and Konopińska-Zmysłowska, V., On Dynamic Extension of a Local Material Symmetry Group for Micropolar Media, *Symmetry*, vol. **12**, no. 10, p. 1632, 2020.
- Eremeyev, V.A., Lebedev, L.P., and Altenbach, H., *Foundations of Micropolar Mechanics*, Springer Briefs in Applied Sciences and Technologies, Heidelberg: Springer, 2013.
- Eringen, A.C., *Microcontinuum Field Theory. I. Foundations and Solids*, New York: Springer, 1999.
- Eringen, A.C. and Kafadar, C.B., Polar Field Theories, *Continuum Physics.*, Eringen, A.C., Ed., New York: Academic Press, vol. **IV**, pp. 1–75, 1976.
- Fantuzzi, N., Trovalusci, P., and Dharasura, S., Mechanical Behavior of Anisotropic Composite Materials as Micropolar Continua, *Front. Mater.*, vol. **6**, p. 59, 2019.
- Fantuzzi, N., Trovalusci, P., and Luciano, R., Material Symmetries in Homogenized Hexagonal-Shaped Composites as Cosserat Continua, *Symmetry*, vol. **12**, no. 3, p. 441, 2020.
- Fleck, N.A., Deshpande, V.S., and Ashby, M.F., Micro-Architected Materials: Past, Present, and Future, *Proc. R. Soc. A: Math. Phys. Eng. Sci.*, vol. **466**, no. 2121, pp. 2495–2516, 2010.
- Izadi, R., Tuna, M., Trovalusci, P., and Fantuzzi, N., Bending Characteristics of Carbon Nanotubes: Micropolar Elasticity Models and Molecular Dynamics Simulations, *Mech. Adv. Mater. Struct.*, 2021a. (in press)



- Izadi, R., Tuna, M., Trovalusci, P., and Ghavanloo, E., Torsional Characteristics of Carbon Nanotubes: Micropolar Elasticity Models and Molecular Dynamics Simulation, *Nanomaterials*, vol. **11**, no. 2, pp. 1–20, 2021b.
- Lakes, R., Foam Structures with a Negative Poisson's Ratio, *Science*, vol. **235**, no. 4792, pp. 1038–1040, 1987.
- Lakes, R., *Composites and Metamaterials*, Singapore: World Scientific, 2020.
- Lakes, R., Experimental Microelasticity of Two Porous Solids, *Int. J. Solids Struct.*, vol. **22**, no. 1, pp. 55–63, 1986.
- Leonetti, L., Greco, F., Trovalusci, P., Luciano, R., and Masiani, R., A Multiscale Damage Analysis of Periodic Composites Using a Couple-Stress/Cauchy Multidomain Model: Application to Masonry Structures, *Compos. Part B: Eng.*, vol. **141**, pp. 50–59, 2018.
- Lurie, A.I., *Analytical Mechanics*, Berlin: Springer, 2001.
- Maugin, G.A. and Metrikine, A.V., *Mechanics of Generalized Continua. One Hundred Years after the Cosserats*, Advances in Mechanics and Mathematics, Berlin: Springer, 2010.
- Mindlin, R.D., Influence of Rotatory Inertia and Shear on Flexural Motions of Isotropic Elastic Plates, *Trans. ASME. J. Appl. Mech.*, vol. **18**, pp. 31–38, 1951.
- Nowacki, W., *Theory of Asymmetric Elasticity*, Oxford, UK: Pergamon Press, 1986.
- Pan, C., Han, Y., and Lu, J., Design and Optimization of Lattice Structures: A Review, *Appl. Sci.*, vol. **10**, no. 18, 2020.
- Pau, A. and Trovalusci, P., Block Masonry as Equivalent Micropolar Continua: The Role of Relative Rotations, *Acta Mech.*, vol. **223**, no. 7, pp. 1455–1471, 2012.
- Phani, A.S. and Hussein, M.I., *Dynamics of Lattice Materials*, Hoboken, NJ: Wiley–Blackwell, 2017.
- Pietraszkiewicz, W., Refined Resultant Thermomechanics of Shells, *Int. J. Eng. Sci.*, vol. **49**, no. 10, pp. 1112–1124, 2011.
- Pietraszkiewicz, W. and Eremeyev, V.A., On Natural Strain Measures of the Non-Linear Micropolar Continuum, *Int. J. Solids Struct.*, vol. **46**, nos. 3-4, pp. 774–787, 2009.
- Pingaro, M., de Bellis, M.L., and Trovalusci, P., A Virtual Element Approach for Micropolar Continua, in *Proc. of 15th Int. Conf. on Computational Plasticity. Fundamentals and Applications, COMPLAS 2019*, Florence, Italy, pp. 235–248, 2019.
- Reccia, E., De Bellis, M.L., Trovalusci, P., and Masiani, R., Sensitivity to Material Contrast in Homogenization of Random Particle Composites as Micropolar Continua, *Compos. Part B: Eng.*, vol. **136**, pp. 39–45, 2018a.
- Reccia, E., Leonetti, L., Trovalusci, P., and Cecchi, A., A Multiscale/Multidomain Model for the Failure Analysis of Masonry Walls: A Validation with a Combined FEM/DEM Approach, *Int. J. Multiscale Comput. Eng.*, vol. **16**, no. 4, pp. 325–343, 2018b.
- Rubin, M.B., *Cosserat Theories: Shells, Rods and Points*, Dordrecht: Kluwer, 2000.
- Shi, F., Fantuzzi, N., Trovalusci, P., Li, Y., and Wei, Z., The Effects of Dilatancy in Composite Assemblies as Micropolar Continua, *Compos. Struct.*, vol. **276**, p. 114500, 2021.
- Simmonds, J.G., *A Brief on Tensor Analysis*, 2nd ed., New York: Springer, 1994.
- Trovalusci, P., De Bellis, M.L., and Masiani, R., A Multiscale Description of Particle Composites: From Lattice Microstructures to Micropolar Continua, *Compos. Part B: Eng.*, vol. **128**, pp. 164–173, 2017.
- Trovalusci, P., De Bellis, M.L., Ostoja-Starzewski, M., and Murrall, A., Particulate Random Composites Homogenized as Micropolar Materials, *Meccanica*, vol. **49**, no. 11, pp. 2719–2727, 2014.
- Trovalusci, P., Ostoja-Starzewski, M., De Bellis, M.L., and Murrall, A., Scale-Dependent Homogenization of Random Composites as Micropolar Continua, *Eur. J. Mech., A: Solids*, vol. **49**, pp. 396–407, 2015.
- Truesdell, C. and Noll, W., *The Non-Linear Field Theories of Mechanics*, 3rd ed., Berlin: Springer, 2004.
- Vilchevskaya, E.N., Müller, W.H., and Eremeyev, V.A., Extended Micropolar Approach within the Framework of 3M Theories and Variations Thereof, *Continuum Mech. Thermodyn.*, vol. **34**, pp. 1–22, 2022.

