



Increasing the Utilization of dc-link Voltage of a Five-leg VSI Based on Rotor Angle Control of Dual Induction Motors

Dmytro Kondratenko , Arkadiusz Lewicki  and Charles Odeh 

*Faculty of Electrical and Control Engineering
Gdańsk University of Technology
Gdańsk, Poland*

Email: dmytro.kondratenko@pg.edu.pl, arkadiusz.lewicki@pg.edu.pl, charles.odeh@pg.edu.pl

Abstract—This paper introduces an increased utilization of the dc-link voltage of a five-leg voltage source inverter (VSI) based on the rotor flux angle control technique for dual induction motors, IM. The main purpose is to utilize additional abilities provided by a multi-motor drive system in limited operating conditions. Generally, a multi-motor drive system is widely used in electric vehicles (EVs), traction systems and in several industrial applications. A dual IM drive system is investigated in this paper, where field-oriented control (FOC) scheme and space vector pulse-width modulation (SVPWM) technique are used for the drives control. Therein, additional rotor angle control is implemented to increase the maximum modulation index. The proposed control technique allows the control of two independent three-phase IM. Under limited conditions, both motors can achieve high modulation index values and decreased losses as well. Simulation studies and results carried out in PLECS software package show the effectiveness and feasibility of the proposed control strategy. Experimental results presented proved the idea of the proposed solution.

Index Terms—five-leg inverter, multi-motor system, dual IMs, rotor angle control

I. INTRODUCTION

The research interest in multi-motor drive systems is continuously increasing during the last decades. A lot of studies have been done to reduce the drive-system size, cost and power component-count. Multi-motor drive system (MMDS) concept could be found in EVs, traction systems, textile and steel industrial applications. One of the solutions proffered so far is to deploy five-phase inverter in order to reduce cost and size of MMDS. Two separate 3-phase inverter can be configured as a single five-phase inverter by connecting one phase of each motor to the common phase of the inverter, [1]–[5]. A few publications discuss different controls [6], [7], and pulse-width modulation (PWM) techniques, [8]–[12] for permanent magnet synchronous motors (PMSMs) and for induction motors (IMs), as well. Moreover, the power converter topologies for MMDS are widely discussed research topic. Several solutions utilize

common phase, [13]; other ones use additional active switches in each inverter-leg, [14]–[16].

This paper presents an increased utilization of the dc-link voltage of a five-leg VSI based on rotor flux angle control of dual IMs. A Dual IM drive system is driven under a field-oriented control schemes, and space vector pulse-width modulation technique. Additional rotor flux angle control is proposed herein to increase the maximum modulation index in certain operational conditions and to decrease the losses in the common phase as well. Here, the frequency of the two motors is relatively equal and the mutual angle difference is set by the proposed curve presented in the following part of this work. Specified operational conditions are: both motors should have the same or relatively equal angular rotor flux speed. The proposed control technique gives the degree of freedom to control independently dual three-phase IM. In this way, EVs and traction systems are the best fields for the proposed solution.

In the following sections, this paper is organized as follows: the control scheme is given in section II, where the main principles are mentioned; the simulation results are presented in section III, with research data discussion; in section IV, the experimental results are given; the future plan and conclusion results are presented in section V.

II. PROPOSED CONTROL TECHNIQUE

The conventional control schemes are focus on full operational range conditions, where the maximum modulation index, $M_{dual\ max} = M_1 + M_2 \leq 1.1547$. However, this approach involves limitation of motors' controlling parameters with the available modulation index and the common phase current control. Conventional control schemes follow the basic linear modulation region and cannot achieve the highest modulation index value of 0.57735; due to the natural limitation. Basic linear modulation region is shown in Fig. 2, which represents the available dc-link voltage and modulation index of both motors in any operational condition.

The control technique proposed in this paper has been implemented as an additional part of the FOC control scheme.

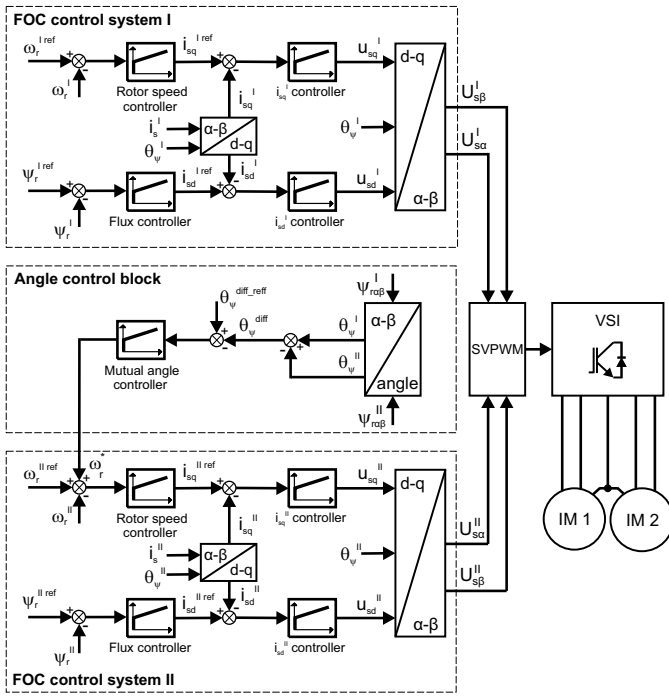

Fig. 1. Proposed control scheme with FOC block diagram.

Dual IMs structure requires the use of an independent FOC control block for both motors. Fig. 1 shows a structure of the proposed scheme. In this figure, two FOC control systems, consisting of rotor angular speed, flux and current controllers, rotor angle flux control block and mutual angle difference PI controller, are deployed. Basically, the FOC concept is well-known now and the solution utilized in this paper is the typical adaptation of the FOC concept.

Generally, rotor angle control block could be accomplished in two different ways. The first one, is to obtain actual angles from voltage components, $U_{s\alpha}^I, U_{s\beta}^I, U_{s\alpha}^{II}, U_{s\beta}^{II}$, and synchronize them with mutual angle reference value. The second approach is to utilize flux components, $\psi_{s\alpha\beta}^I, \psi_{s\alpha\beta}^{II}$, and synchronize rotor flux angles, $\theta_{\psi}^I, \theta_{\psi}^{II}$, with mutual angle reference value.

Proposed solution is based on flux components and naturally limited to operate with the same load for both motors. Control algorithm takes into account flux control signals, $\psi_{s\alpha\beta}^I, \psi_{s\alpha\beta}^{II}$, from both FOC blocks and process these input signals to obtain the current rotor flux angles, $\theta_{\psi}^I, \theta_{\psi}^{II}$. In one rotor angle block computations, (1) and (2) were used:

$$\theta_{\psi}^n = \text{atan}(\psi_{s\alpha}^n, \psi_{s\beta}^n) \quad (1)$$

where n is a motor/FOC control system number

$$\theta_{\psi}^{diff} = \theta_{\psi}^I - \theta_{\psi}^{II} \quad (2)$$

θ_{ψ}^{diff} – shown the actual mutual angle between two motors, and required to obtain an error for a PI controller, (3).

$$\text{error} = \theta_{\psi}^{diff\ ref} - \theta_{\psi}^{diff} \quad (3)$$

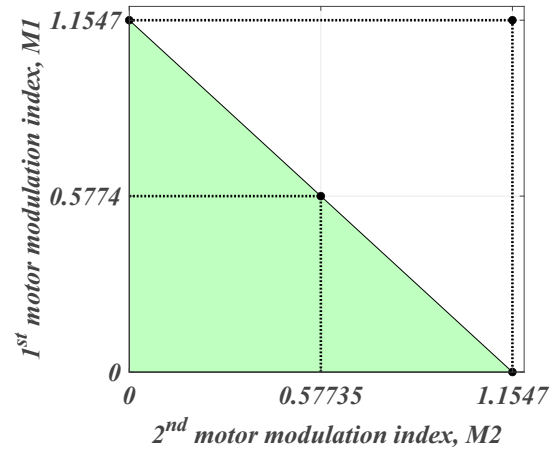

Fig. 2. Linear modulation region for both motor in any operation condition.

where $\theta_{\psi}^{diff\ ref}$ is a mutual angle reference value.

After all, mutual angle PI controller process the error value and compute a control signal, ω_r^* . An additional angular speed component, ω_r^* (after injection to the angular speed control line) increase or decrease the rotational speed of the one motor for a moment and allow us to achieve the defined purposes. At the same time, both FOC block generate output signals, $U_{s\alpha}^I, U_{s\beta}^I, U_{s\alpha}^{II}, U_{s\beta}^{II}$. These signals are fed to the SVPWM modulation block after the feedback response received from the angle difference controller.

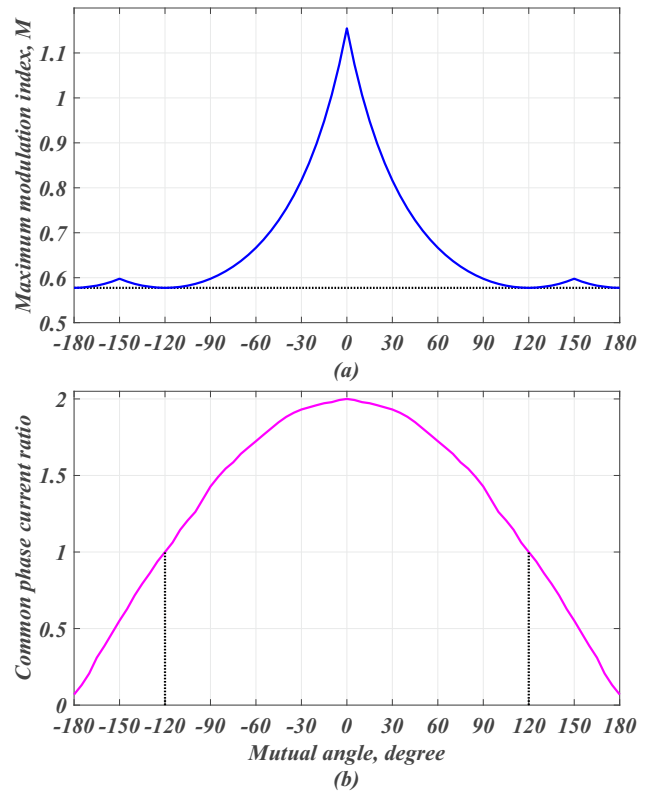

Fig. 3. Mutual angle dependents to (a) available modulation index zone; (b) common phase current ratio.

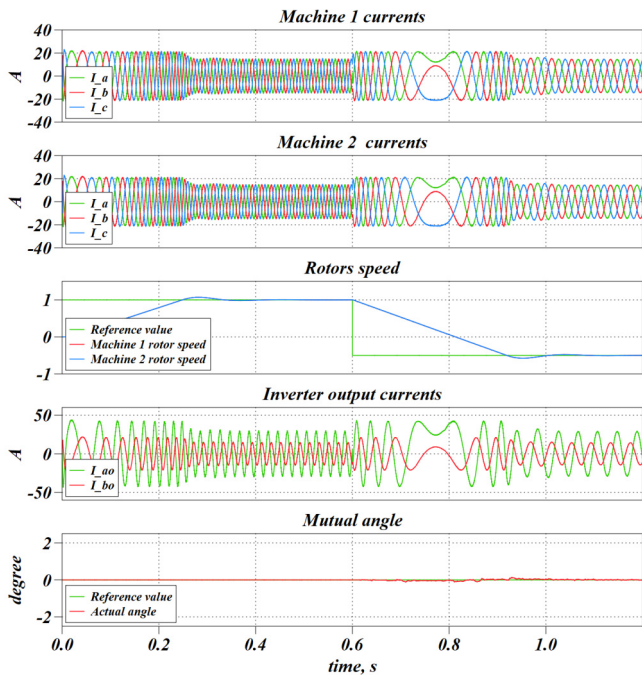

Fig. 4. Machines currents, rotors speed, inverter common and one other phase currents, the mutual angle (0 degree), under the step change in rotor speed.

The rotor flux angle control of each motor in limited operating conditions allows us to increase the maximum modulation index. In conditions where the frequency of the two motors is relatively equal, the maximum modulation index, M , depends on rotor angle difference. Improvement can be achieved due to the curve presented in Fig. 3(a), where M is the maximum modulation index for a single motor. Both IM can achieve the modulation index $M = 1.1547$ at the same time if we allow them to utilize common leg in full current ratio zone. In case of $M_1 = M_2 = 1.1547$, the current in the common phase will be two times higher, than in other phases.

The common phase current ratio dependence presented in Fig. 3(b), depicts two interesting zones. In the first zone, the mutual angle variation is between -10 and 10 degrees. This allows us to achieve the maximum modulation index; however, the consequence is doubling of current in the common phase. The second zone has mutual angle variation between -180 and -120 or 120 and 180 degrees. This allows us to decrease the current in the common phase, which leads to a reduction in switching and conduction losses. This current decrease has slight impact on modulation index. In this second zone, similar modulation index value as in conventional control schemes is achieved; where $M_1 = M_2 = 0.57735$.

III. SIMULATION RESULTS

Simulation studies are done in PLECS software package. The main focus of this research is to present inverter and machines' behaviors under different conditions. During these studies, step change in the angular speed was used in order to verify the angle control block response in stable- and dynamic-state modes. All figures show the inverter output currents, the rotor speed, currents of both machines and actual mutual angle.

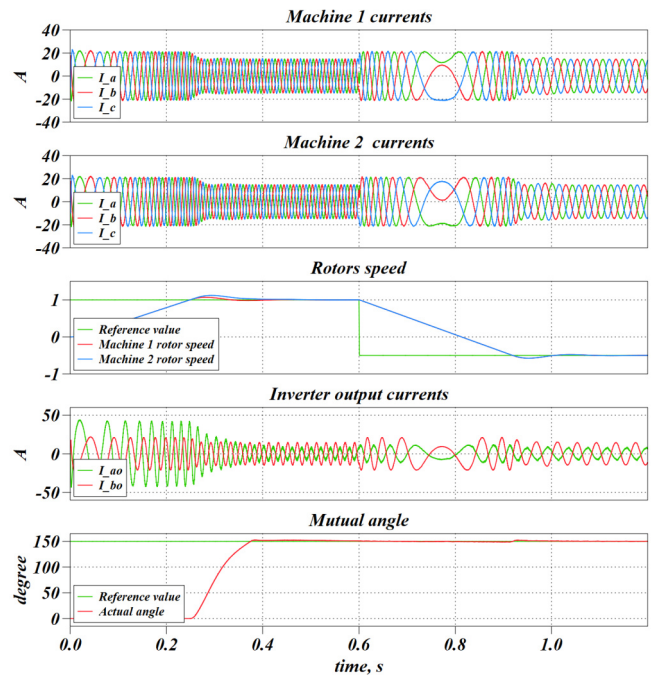

Fig. 5. Machines currents, rotors speed, inverter common and one other phase currents, the mutual angle (150 degree), under the step change in rotor speed.

Fig. 4 shows the MMS behavior under the rotor flux angle control, with the angle difference set to 0 degrees between IMs. Obtained waveforms have the appropriate shape and the rotor speed is controlled effectively in both directions. The common phase current is two time higher than in other phases, however, this is an absolute maximum point, which allow us to achieve $M_1 = M_2 = 1.1547$.

The mutual angle region (where the value of θ_{ψ}^{diff} is in the range $[-120; -30]$ or $(30; 120]$) is characterized by relatively small improvement in maximum modulation index value. This can be achieved, from 0.5773 to 0.8175. At the same time, the common phase current ratio is increased from 1 to 1.93, respectively. All possible mutual angle values from this region can be easily obtained from Fig. 3. Consequently, the working points located in this region are undesirable for stable-state mode due to higher losses with slight improvement in available modulation index value. The several undesirable working points and their crucial characteristics are indicated in Table I.

TABLE I
UNDESIRABLE WORKING POINTS

Mutual angle, degree	Modulation index, M	Common phase current ratio
30 / -30	0.8175	1.93
60 / -60	0.6665	1.72
90 / -90	0.5877	1.43
120 / -120	0.57735	1

The reference mutual angle value was set to 150 degree is a local maximum on modulation index curve and Fig. 5 shows

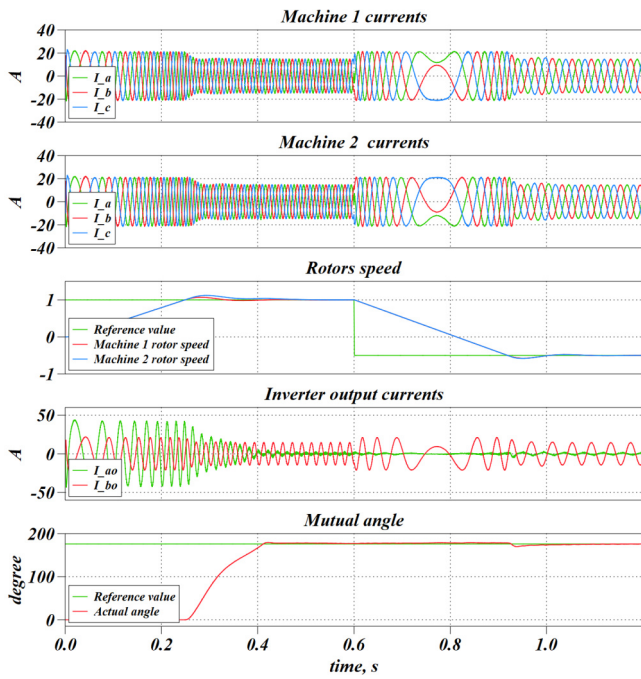

Fig. 6. Machines currents, rotors speed, inverter common and one other phase currents, the mutual angle (179 degree), under the step change in rotor speed.

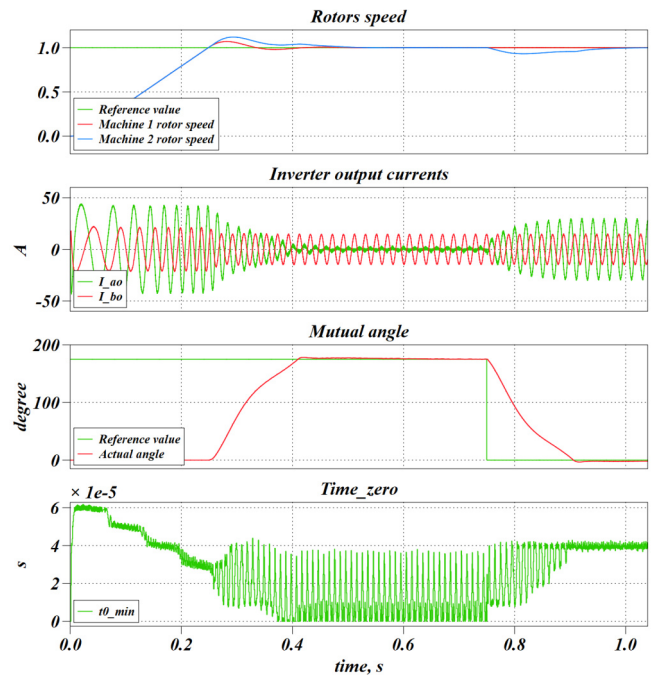

Fig. 7. Rotors speed, inverter common and one other phase currents, the mutual angle and the minimal zero time, under the step change in mutual angle, from 0 to 179 and back.

the MMDS behavior under the rotor flux angle control, with this mutual angle between IMs. Not only improved modulation index can be achieved at this point, the common phase current ratio is 0.55 of nominal. Local maximum modulation index is $M_1 = M_2 = 0.5977$. The output current waveforms have the appropriate shape and the rotor speed is controlled effectively in both directions, as in previous operation.

To reduce the switching and conduction losses up to 20% the common phase current could be decreased. It can be achieved when the mutual angle value lead to 180 or -180 degree. Fig. 6 shows the inverter output currents, the rotors speed, currents of both machines and actual mutual angle, when the $\theta_{\psi}^{diff} = 179$ degree. Obtained waveforms characterized by appropriate shape, the rotor speed and mutual angle are controlled effectively in both directions. The common phase current is fluctuating around 0, and maximum modulation index is equal to those of conventional control schemes $M_1 = M_2 = 0.57735$.

The three most interesting working points are indicated in the Table II. Two of them are the local maximum points of modulation index, where mutual angle are -150/150 and 0 degree. These points should be considered as a highly prioritize values in each industrial applications, where mutual angle control is supposed to be implemented.

Fig. 7 shows the dual drive system behavior under the rotor flux angle control, with the step change on mutual angle value, from 0 to 180 degree, and back. Obtained current waveforms show the reduced current amplitude, when mutual angle is 180 degrees. Time t_{0min} can be used for proportional lengthening of active vectors and achieving a higher value of

TABLE II
FEATURED WORKING POINTS

Mutual angle, degree	Modulation index, M	Improvement in M, %	Common phase current ratio
180 / -180	0.57735	0	0
150 / -150	0.59775	3.5	0.55
0	1.1547	100	2

the modulation index. In case of $t_0 = 0$, machine works in overmodulation region.

With $\theta_{\psi}^{diff} = 0$ degree, the highest angular speed can be reached by reducing time t_{0min} , as shown in Fig. 8. The system dynamic response on the rotor speed change is shown.

Simulation studies show the compliance of the proposed control scheme with the declared characteristics. Dual IMs drive system can be controlled effectively in both directions. Additionally, control signal injection leads to increased available maximum modulation index or reduced losses. The flux and voltage components have the appropriate shape for both motors as well as their current waveforms. The proposed rotor flux angle control focused on the flux angles processing and the output control signal calculation to inject it in angular speed control line. The angle control block allows to maintain a constant mutual angle, the angle difference between two motors, in stable- and dynamic-state modes. The parameters of PI controller used in this research should be determined for each application due to the nature of process. The idea of the proposed concept involves smooth adjustment of the mutual angle, so that the adjustment process takes place imperceptibly for the end user.



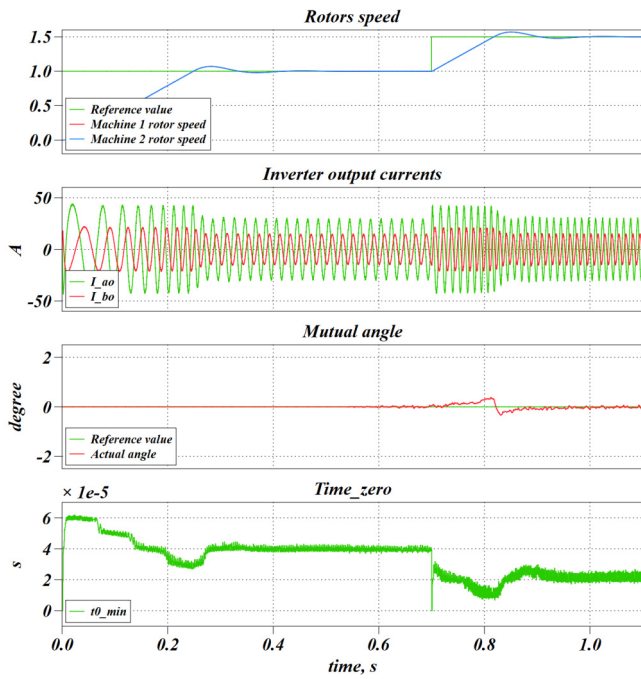

Fig. 8. Rotors speed, inverter common and one other phase currents, the mutual angle and the minimal zero time, under the step change in rotor speed, from 0 to 1 and to 1.5.

IV. EXPERIMENTAL RESULTS

Experimental studies are carried out using five-phase, two-level NPC inverter connected to dual IMs. During the studies, a set of key values was measured and registered. The main focus of the experimental part is to verify the proposed control concept, and to show the MMDS behavior. Presented figures show the dynamic responses on the rotor speed and the mutual angle change.

Fig. 9 shows the MMDS behavior under the rotor angle flux control, with rotor speed change from 0.1 to 0.4. The current in common phase is shown as well. During the whole time the rotor angle control block successfully maintained the set value, $\theta_{\psi}^{diff} = \theta_{\psi}^{diff ref} = 0$ degree. The common phase current amplitude is the same for stable mode. Nevertheless, in the dynamic mode, when the speed changing fast, the current peak can be measured.

The dynamic system response on step change in the mutual angle value, from 180 to 0 degree is shown in Fig. 10. Mutual angle 180 degree allow us to reduce the losses up to 20%, which can be proved by common phase current reduction shown in Fig. 10. Additionally, rotor speed waveform shows the mechanism, how the control block synchronizes the angles by slight speed change in one motor.

Fig. 11 shows the MMDS behavior under the rotor angle flux control, with mutual angle variation from 180 to 150; and then from 120 to 0 degree. The currents in the common and one of the other phases are shown as well. The different mutual angle values represent the possible working regions. With $\theta_{\psi}^{diff ref} = 180$ degree, the losses reduced up to 20%. in case of 150 degrees, the common phase current is 55% of other

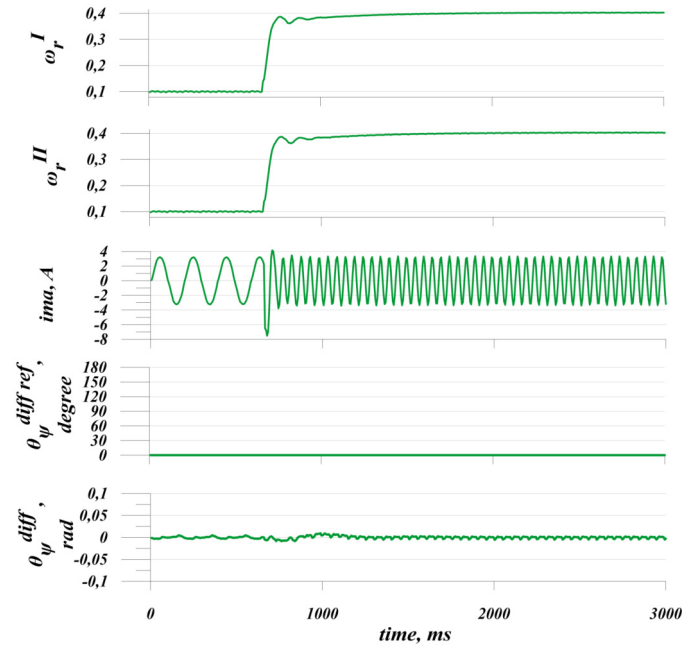

Fig. 9. Rotors speed, inverter common phase current, the reference and estimated mutual angle, under the step change in rotor speeds, from 0.1 to 0.4.

phase current. This means smaller losses and slightly increased modulation index, than in conventional solutions. The changes in modulation index can be obtained from Fig. 3. Mutual angle, $\theta_{\psi}^{diff ref} = 120$ degree represent an undesirable working point, when we have the same characteristics as conventional schemes.

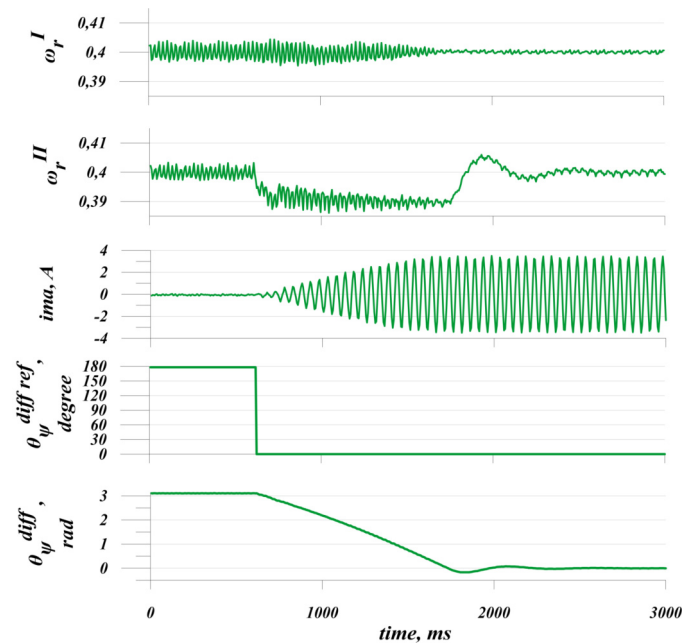

Fig. 10. Rotors speed, inverter common phase current, the reference and estimated mutual angle, under the step change in mutual angle, from 179 to 0 degree.

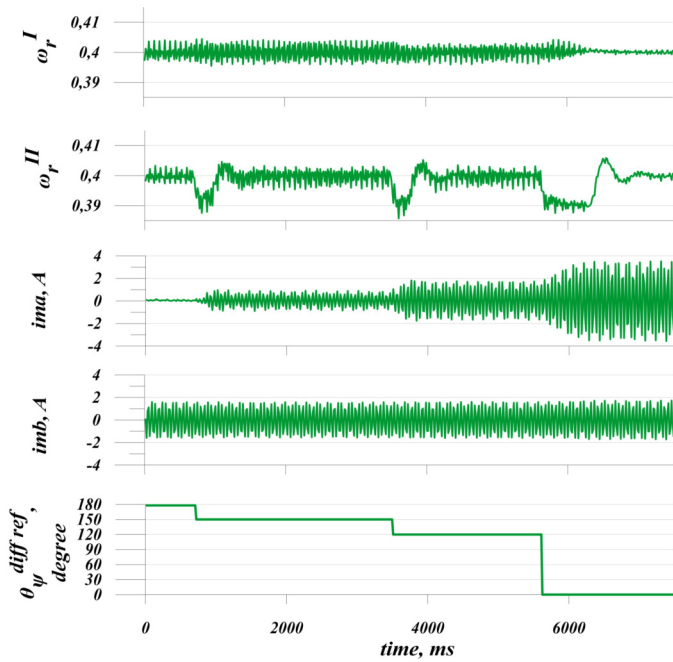

Fig. 11. Rotors speed, inverter common and one other phase currents, the reference and estimated mutual angle, under the step change in mutual angle, from 179 to 150, to 120 and than to 0 degree.

The last working point, presented in Fig. 11 is $\theta_{\psi}^{diff\ ref} = 0$ degree. This zone characterized the highest maximum modulation index, which can be reached, and increased common phase current, $i_{common} = 2 \cdot i_{any\ other}$.

Obtained experimental results show the effectiveness and feasibility of the proposed control strategy. Possible working points were mentioned and undesirable point, which represent a conventional control scheme, was also shown.

V. CONCLUSIONS

The proposed control scheme allows for the improvement of dc-link utilization under limited operational condition. Rotor flux angle control allows us to achieve better relationship between utilization of dc-link voltage and current amplitude in the common phase. The reduced output current in the common phase and, consequently, reduced switching and conduction losses, up to 20%, can be reached as well. In comparison with previous works, this paper proposes to utilize an additional rotor angle control block in order to achieve higher performance or to reduce the losses under limited operational condition. The verification of this concept shows the two direction in the possible application: to improve dual drive system performance by utilizing high modulation index values, or to improve system performance by decreasing the current amplitude in the common phase. The proposed control scheme should be considered as an additional control block to existing solution. The main purpose of this scheme is to inject the control signal when the dual IMs work with same or nearly equal angular rotor flux speed. In any other conditions, proposed control scheme will be characterized by

the same results as well-known solutions. The idea of the proposed solution was proven using the results of simulation and experimental studies.

REFERENCES

- [1] M. Jones, D. Dujic, E. Levi, M. Bebic and B. Jlefenic, "A two-motor centre-driven winder drive fed by a five-leg voltage source inverter," 2007 European Conference on Power Electronics and Applications, 2007, pp. 1-10, doi: 10.1109/EPE.2007.4417243.
- [2] K. Oka, Y. Ohama, H. Kubota, I. Miki and K. Matsuse, "Characteristic of Independent Two AC Motor Drives Fed by a Five-Leg Inverter," in 2009 IEEE Industry Applications Society Annual Meeting, 2009, pp. 1-8, doi: 10.1109/IAS.2009.5324838.
- [3] K. Oka, Y. Nozawa and K. Matsuse, "Improved method of voltage utility factor for PWM control method of five-leg inverter," in 2006 37th IEEE Power Electronics Specialists Conference, 2006, pp. 1-5, doi: 10.1109/pesc.2006.1711820.
- [4] T. Nagano and J. Itoh, "Design of multi-parallel drive technique for system with numbers of Permanent Magnet Synchronous Motors," in 2013 IEEE 10th International Conference on Power Electronics and Drive Systems (PEDS), 2013, pp. 193-198, doi: 10.1109/PEDS.2013.6527013.
- [5] A. Dixit, N. Mishra, S. K. Sinha and P. Singh, "A review on different PWM techniques for five leg voltage source inverter," in IEEE-International Conference On Advances In Engineering, Science And Management (ICAESM -2012), 2012, pp. 421-428.
- [6] Z. Ibrahim, J. M. Lazi and M. Sulaiman, "Independent speed sensorless control of dual parallel PMSM based on Five-Leg Inverter," in International Multi-Conference on Systems, Signals and Devices, 2012, pp. 1-6, doi: 10.1109/SSD.2012.6198021.
- [7] J. M. Lazi, Z. Ibrahim, M. Sulaiman, A. M. Razali and N. Kamisman, "Independent control for dual-PMSM drives using Five-Leg Inverter," in 2015 IEEE Conference on Energy Conversion (CENCON), 2015, pp. 143-148, doi: 10.1109/CENCON.2015.7409529.
- [8] S. N. Vukosavic, M. Jones, D. Dujic and E. Levi, "An improved PWM method for a five-leg inverter supplying two three-phase motors," in 2008 IEEE International Symposium on Industrial Electronics, 2008, pp. 160-165, doi: 10.1109/ISIE.2008.4676881.
- [9] A. Hara, H. Enokijima and K. Matsuse, "Independent vector control of two induction motors fed by a five-leg inverter with space vector modulation," in 2011 IEEE Industry Applications Society Annual Meeting, 2011, pp. 1-8, doi: 10.1109/IAS.2011.6074311.
- [10] N. Mohd Yaakop, Z. Ibrahim, M. Sulaiman and M. H. N. Talib, "Speed performance of SVPWM direct torque control for five leg inverter served dual three-phase induction motor," in 2012 IEEE International Power Engineering and Optimization Conference Melaka, Malaysia, 2012, pp. 323-328, doi: 10.1109/PEOCO.2012.6230883.
- [11] Yang Mei and Shuaiwei Feng, "An optimized modulation method for a five-leg-inverter for dual Induction motor drives," in 2016 IEEE 8th International Power Electronics and Motion Control Conference (IPEMC-ECCE Asia), 2016, pp. 660-663, doi: 10.1109/IPEMC.2016.7512363.
- [12] M. Jones, D. Dujic and E. Levi, "A performance comparison of PWM techniques for five-leg VSIs supplying two-motor drives," in 2008 34th Annual Conference of IEEE Industrial Electronics, 2008, pp. 508-513, doi: 10.1109/IECON.2008.4758005.
- [13] C. I. Odeh, A. Lewicki, M. Morawiec and J. O. Ojo, "A Five-Leg Three-Level Dual-Output Inverter," in IEEE Transactions on Circuits and Systems II: Express Briefs, 2022, doi: 10.1109/TCSII.2022.3211273.
- [14] R. Wang, L. Ai and C. Liu, "A Novel Three-Phase Dual-Output Neutral-Point-Clamped Three-Level Inverter," in IEEE Transactions on Power Electronics, vol. 36, no. 7, pp. 7576-7586, July 2021, doi: 10.1109/TPEL.2020.3032124.
- [15] J. Haruna and N. Hoshi, "A Novel Three-level inverter which can drive two PMSMs," 7th IET International Conference on Power Electronics, Machines and Drives (PEMD 2014), 2014, pp. 1-6, doi: 10.1049/cp.2014.0376.
- [16] R. Wang, S. Yuan, C. Liu, D. Guo and X. Shao, "A Three-Phase Dual-Output T-Type Three-Level Converter," in IEEE Transactions on Power Electronics, doi: 10.1109/TPEL.2022.3153073.

