

A NEW APPROACH TO DESIGNING CONTROL OF DISSOLVED OXYGEN AND AERATION SYSTEM IN SEQUENCING BATCH REACTOR BY APPLIED BACKSTEPPING CONTROL ALGORITHM

Michał KOLANKOWSKI*^{ORCID}, Michał BANACH*^{ORCID}, Robert PIOTROWSKI*^{ORCID},**^{ORCID}, Tomasz UJAZDOWSKI*^{ORCID}

*Faculty of Electrical and Control Engineering, Gdańsk University of Technology,
G. Narutowicza 11/12, 80-233 Gdańsk, Poland

**Digital Technologies Center, Gdańsk University of Technology,
G. Narutowicza 11/12, 80-233 Gdańsk, Poland

s176294@student.pg.edu.pl, s176230@student.pg.edu.pl, robert.piotrowski@pg.edu.pl, tomasz.ujazdowski@pg.edu.pl

received 25 January 2023, revised 25 May 2023, accepted 16 June 2023

Abstract: The wastewater treatment plant (WWTP) is a complex system due to its non-linearity, time-variance and multiple time scales in its dynamics among others. The most important control parameter in a WWTP is the dissolved oxygen (DO) concentration. The tracking problem of the DO concentration is one of the most fundamental issues in biological wastewater treatment. Proper control of DO concentration is necessary to achieve adequate biological conditions for microorganisms in the WWTP. Aeration is an important process to achieve those conditions, but it is expensive. It was performed using an aeration system, which includes blowers, pipelines and diffusers. This paper presents a new approach to designing a non-linear control system for controlling DO concentration using an adaptive backstepping algorithm. A model of biological processes and aeration system were applied in designing the control system. Simulation tests of the control system were performed and very good results on control were obtained. The proposed solution has proved to be effective and computationally efficient.

Keywords: aeration system, backstepping control algorithm, dissolved oxygen, non-linear system, wastewater treatment plant, SBR

1. INTRODUCTION

The growth of global population and rising urbanization have contributed to diminishing clean water supply and irreversibly damaging many ecosystems. Therefore, uncontrolled disposal of wastewater and waste, which relies solely on the self-purifying properties of natural ecosystems, is not acceptable. The scientific and technical development allows to create better solutions in the field of wastewater treatment and reduces the negative effect on the environment, health and quality of people's lives [1].

In this paper, a municipal, biological, batch-type (sequencing batch reactor [SBR]) wastewater treatment plant (WWTP) with fine-bubble compressed air aeration is applied. The biological processes occurring in a WWTP are complex dynamic, non-linear, time-variant processes with many interactions and varying time constants. Thus, it is justified to apply modern control algorithms to such a system. The main goal of developing new control methods for a WWTP is to improve pollution indices and maintain acceptable pollutant concentrations in the effluent, according to the water-law permit. Moreover, the objective is to improve the efficiency, i.e. reduce the operational costs of a WWTP, in particular, the cost of pumping air through the aeration system [2].

One of the most important factors that have an impact on the biological wastewater treatment process is dissolved oxygen (DO) concentration. The population and activity of waste-treating microorganisms vary depending on this factor. The demanded DO concentration is guaranteed through the wastewater aeration

process. Additionally, it is used for mixing the activated sludge and raw wastewater. However, the aeration process generates the highest power consumption out of all the elements of the treatment process, and thus the highest operational costs of a WWTP [3]. Therefore, an efficient DO concentration and aeration system control allows to reduce these costs.

The history of designing control algorithms for biological processes in the activated sludge process dates back to the 1970s and 1980s. The examples of early DO concentration control algorithms are a self-tuning, robust controller [4] and an adaptive controller with an online estimation of oxygen transfer and respiration rates [5]. With the advancement of digital technology and increasing possibilities for automatic control algorithm implementation, more advanced control methods were developed, e.g., model predictive control (MPC). This method was used in the literature [6], where instead of generating a reachable reference trajectory, process performance was optimised using the economic objective function. In the literature [7], the authors proposed a two-level hierarchical control system with the supervisory layer (MPC and Fuzzy) designating the setpoint of the DO concentration based on the ammonia composition and the lower layer controller (proportional-integral [PI]) dealing with DO concentration. Another fuzzy controller in the supervisory layer, which calculates the setpoint of DO concentration and adapts parameters of the lower control layer, was presented in the literature [8]. Fuzzy logic may also be applied in direct DO concentration control, e.g., using a fuzzy-proportional-integral-derivative (PID) control strategy [9]. In the literature [10], an adaptive PID controller with a radial basis

function network for parameter adaptation was used to control the DO concentration.

Designing model-based control (MPC) requires not only knowledge of the system and the design of utility models but also significant computational resources. Another challenge is the non-linear nature of the DO and aeration system equations, and in the literature, one often encounters the use of approaches dedicated to solving linear problems, which can have negative effects on system robustness. Fuzzy control solutions have many advantages; however, their development requires substantial expert knowledge about the system and the formulation of a set of rules. Furthermore, despite the popularity of fuzzy control in academic research, it has limited practical implementations in various fields [11]. Another drawback of algorithms that require significant expert knowledge (MPC and Fuzzy) is the social concerns of operators and technologists regarding new technologies. On the other hand, popular PID controllers with fixed parameters are simple algorithms designed for linear problems. They remain popular, especially with additional modifications for parameter adaptation. However, in practice, most controllers of this type operate in basic versions with suboptimal settings or settings determined by engineering methods, prioritizing system stability without considering the quality.

The proposed adaptive backstepping algorithm is dedicated to non-linear problems, ensuring stability in the Lyapunov sense. Furthermore, due to its form, it can be easily implemented on programmable logic controllers (PLCs). An additional advantage is the algorithm's adaptation capabilities, which are important in the context of differences between simulation systems and real-world systems where significant disturbances occur.

Aeration is the most important and most expensive activity in WWTP [12]. From a control point of view, this system is dynamic and highly non-linear. Controlling this process using a PID controller with fixed parameters, over a wide operating range, can be

inefficient and ineffective. Therefore, a new approach to designing a non-linear control system for DO concentration control using an adaptive backstepping algorithm is proposed.

The control method considered in this paper is applied in many different fields of technology. The adaptive backstepping method was used in the literature [13] to control a dual-arm of a humanoid robot based on fuzzy approximation. In literature [14], a double-star induction machine control system was designed using the backstepping method. The backstepping approach was applied for reference value tracking of flux and speed and for uncertainty compensation.

The remainder of this paper is organised as follows. Section 2 includes the description of the case-study SBR system and its model, as well as the model of DO concentration and the description of the considered aeration system. The designed control system and its elements, followed by the synthesis of the backstepping controller are presented in Section 3. The simulation results are presented and discussed in Section 4. The paper concludes in Section 5.

2. DESCRIPTION AND MODELLING OF THE CONTROL PLANT

2.1. Sequencing batch reactor

The process of wastewater treatment is divided into physical, biological and chemical methods. This paper concerns only biological methods. In biological treatment, the pollutants are transformed or decomposed by microorganisms. The main objective of biological treatment is to remove or reduce the biodegradable organic matter, nitrogen and phosphorus compounds that are contained in wastewater to an acceptable level, according to the water-law permit [1].

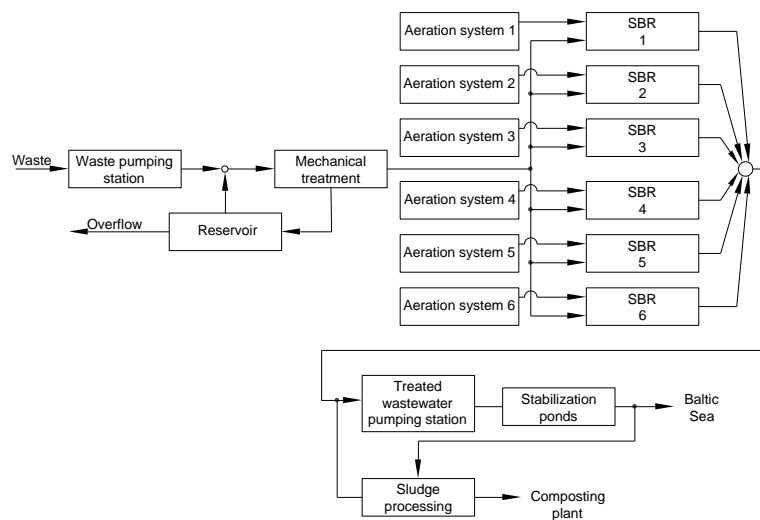

Fig. 1. Scheme of the Swarzewo WWTP

One of the most common biological wastewater treatment methods is the activated sludge method, which is considered in the paper. The activated sludge is a suspension of flocs, which is mainly composed of anaerobic heterotrophic bacteria and other organisms, such as protozoa, rotifera and fungi, as well as mineral particles. Wastewater treatment is based on the mineralization of

organic pollutants present in the effluent by the microorganisms of the activated sludge in controlled conditions. Because of this process, the microorganisms acquire the energy that is necessary for them to live. Additionally, mineral compounds of carbon, nitrogen, phosphorus and sulphur are formed and the biomass grows.

The WWTP in Swarzewo is a biological-chemical-mechanical

system, which means that the treatment process consists of several stages. The first stage of mechanical primary treatment involves the retention of solid contaminants on grids, screens, grit chambers and sand separators. In the secondary stage, which is a biological treatment, the activated sludge method is applied. Then the sludge is separated from the treated wastewater in the sedimentation process. The process may be supported by using chemical reagents.

The biological part of the WWTP in Swarzewo consists of six independent SBRs. The technological scheme of the plant is shown in Fig. 1.

In this paper, the SBR 2 (see Fig. 1) and its aeration system are considered. The reactor's capacity is 5,000 m³. A single SBR cycle includes the following phases: filling, biological reactions (aerobic and anaerobic), sedimentation, decantation and idling. At the end of the treatment process, the treated wastewater is discharged into the Baltic Sea. The excess sludge is removed, further processed, and finally may be used for the fertilization of crops.

In the modelling of biological processes occurring in an SBR, a widely used model Activated Sludge Model No. 2d (ASM2d) was applied [14]. It is an extension of previous models: ASM1 and ASM2. It is one of the most popular descriptions of the activated sludge process. ASM2d consists of 21 biological processes and 19 state variables, 8 of which describe soluble fractions and 11 particulate fractions. The values of those parameters are equal to their default values at 20°C [15]. The model was implemented in the Simba environment, applying data and parameters of the WWTP in Swarzewo [16].

2.2. DO concentration

The DO concentration is one of the most important variables in the control of biological processes. In this paper, the model proposed in the literature [17] was applied:

$$\frac{dDO(t)}{dt} = k_L a (Q_{air,ref}(t)) \cdot (DO_{sat}(t) - DO(t)) + - \frac{DO(t)}{K_{DO} + DO(t)} \cdot R(t) \tag{1}$$

$$k_L a (Q_{air,ref}(t)) = \alpha \cdot Q_{air,ref}(t) \tag{2}$$

where $k_L a (\cdot)$ – oxygen transfer function into sewage through aeration system; $Q_{air,ref}$ – reference trajectory of airflow to SBR [m³/h]; DO_{sat} = 8.63736 – dissolved oxygen saturation concentration [g O₂/m³]; K_{DO} = 2 – Monod constant [g O₂/m³]; R – respiration [g O₂/m³ h]; α = 0.0016 – oxygen transfer coefficient [1/m³].

2.3. Aeration system

During the aerobic phase, the wastewater is aerated by the aeration system (blowers, pipes and diffusers). This is the most expensive process in the WWTP. The scheme of the aeration system is presented in Fig. 2.

The first component is the blower Aerzen AT 150-1.0S with a power of 11 kW. It is connected via the main pipeline with a diameter of 0.4 m and a length of 62.7 m, and then separate pipes to two diffuser systems, which are located in the SBR. Disk membrane diffusers ABS PIK 300 manufactured by Sulzer were used in the system. The working flow range of a single diffuser is 1.5–

8.0 m³/h, which means that it opens, when a pressure of 2 kPa is exceeded. The size of the obtained air bubbles is 1–3 mm. Diffuser systems 1 and 2 consist of 616 and 600 diffusers, respectively.

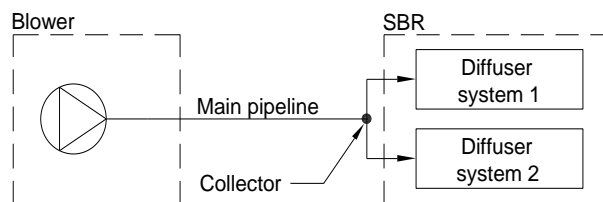

Fig. 2. Structure of the aeration system in the Swarzewo WWTP

Modelling the aeration system in an analogy to an electrical system, based on phenomena characteristic of fluid mechanics, has a long history [18]. In this model, the airflow is analogous to the amperage and the pressure drop is analogous to the voltage in the electrical circuit. The remaining elements are presented as resistors, capacitors, current and voltage sources. Based on the electrical diagrams, a mathematical model was derived. The aeration system was assumed to be a static element compared to the SBR model. The aeration system dynamics are measured in seconds; thus they are much faster compared to the SBR dynamics (minutes and hours). Hence, the aeration system's dynamics can be omitted when designing the control system. The scheme of the aeration system's model is presented in Fig. 3.

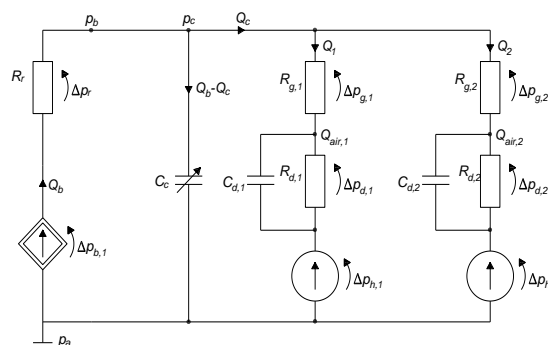

Fig. 3. Aeration system model

Airflow, represented by Q in Fig.3, is an analogy to electric current. Air pressure drop Δp is analogous to voltage drop in electrical systems. The blower was approached, analogically to current sources, as elements with non-linear characteristics of airflow Q_b [m³/h], which is a function of pressure drop on the blower Δp_b [Pa] and its rotational speed n_b [rpm]. Airflow resistance at the connection point of the blower to the main pipeline was modelled by the resistance R_r . The variable resistance C_c was used to model the capacitance of the main pipeline. The two branches of the circuit at the right-hand side of the scheme are a model of two diffuser systems. Resistances $R_{g,j}$ correspond to the airflow resistance of a pipeline leading to each diffuser system. Capacitances $C_{d,j}$ correspond to the capacitances of those pipelines, while resistances $R_{d,j}$ – to airflow resistance of diffusers. The pressure drop $\Delta p_{h,j}$, which occurs in the SBR caused by the aeration system, was modelled as a voltage source.

The characteristic of the blower is further described in Section 3. The pressure drop on the blower is described by the following equation:

$$\Delta p_{b,i} = p_b - p_a \quad (3)$$

where p_b – pressure at the output of the blower [Pa]; $p_a = 1.014 \cdot 10^5$ – atmospheric pressure [Pa].

The resistance R_r , which is a function of the airflow Q_b , is given by:

$$R_r(Q_b) = \frac{\Delta p_r}{Q_b} \quad (4)$$

where Δp_r – pressure drop on the resistance R_r related to the connection point of the blower to the main pipeline [Pa].

Pressure in the main pipeline, its dynamics, and the values describing – the capacitance C_c and the volume of the main pipeline it are as follows:

$$\Delta p_c = \Delta p_{b,i} - \Delta p_r + p_a = p_b - \Delta p_r; i \in \{1,2\} \quad (5)$$

$$\frac{dp_c}{dt} = \frac{1}{C_c} (Q_b - Q_c) \quad (6)$$

$$C_c = k_c V_c p_c; V_c = \frac{1}{4} \pi d_c^2 l_c \quad (7)$$

where p_c – pressure in the main pipeline [Pa]; C_c – air capacitance in the main pipeline [m3]; Q_c – airflow in the main pipeline [m3/h]; k_c – conversion coefficient [m2s4/kg2]; V_c – volume of the main pipeline [m3]; d_c – diameter of the main pipeline [m]; l_c – length of the main pipeline [m].

The values of the parameters k_c , d_c and l_c were determined based on the geometry of the main pipeline. The formulas describing the capacitance of each diffuser system $C_{d,j}$ and volume of each branch of the aeration system $V_{d,j}$ take the following form:

$$C_{d,j} = k_{d,j} V_{d,j} p_{d,j}; V_{d,j} = \frac{1}{4} \pi d_{d,j}^2 l_{d,j}; j \in \{1,2\} \quad (8)$$

where $p_{d,j}$ – pressure in the pipeline in the j -th branch [Pa]; $C_{d,j}$ – air capacitance of the pipeline in the j -th branch [m3]; $k_{d,j}$ – conversion coefficient in the j -th branch [m2s4/kg2]; $V_{d,j}$ – volume of the pipeline in the j -th branch [m3]; $d_{d,j}$ – diameter of the pipeline in the j -th branch [m]; $l_{d,j}$ – length of the pipeline in the j -th branch [m].

The values of the parameters $k_{d,j}$, $d_{d,j}$ and $l_{d,j}$ were determined based on the geometry of the main pipeline.

The resistance $R_{g,j}$, which is a function of the airflow Q_j in the j -th branch, is described by:

$$R_{g,j}(Q_j) = \frac{\Delta p_{g,j}}{Q_j} \quad (9)$$

where $\Delta p_{g,j}$ – pressure drop on the resistance $R_{g,j}$ related to the pipeline of the j -th branch [Pa].

The inflow of air to the diffusers in the branch j $Q_{air,j}$ is as follows:

$$Q_{air,j} = \begin{cases} w_j \frac{\Delta p_{d,j} - \Delta p_{d,j}^{open}}{R_{d,j}} & \text{dla } \Delta p_{d,j} \geq \Delta p_{d,j}^{open} \\ 0 & \text{dla } \Delta p_{d,j} < \Delta p_{d,j}^{open} \end{cases} j \in \{1,2\} \quad (10)$$

where w_j – number of diffusers in the j -th branch[-]; $\Delta p_{d,j}^{open}$ – pressure drop across the pipeline of the j -th branch, necessary to open the diffuser [Pa].

The value of the parameter w_j was determined based on the documentation of the WWTP. The value of $\Delta p_{d,j}^{open}$ was determined based on diffusers' characteristics.

The inflow of air to diffusers has the following dynamics:

$$R_{d,j} C_{d,j} \frac{dQ_{air,j}}{dt} + Q_{air,j} = Q_j; j \in \{1,2\} \quad (11)$$

The pressure drop across the j -th branch is described by:

$$\Delta p_{h,j} = \rho g h_j; j \in \{1,2\} \quad (12)$$

where ρ – density of wastewater in the reactor [kg/m3]; g – standard gravity [m/s2]; h_j – immersion depth of diffusers in the reactor in the j -th branch [m].

The total value of the airflow Q_c inflowing to the system consisting of two diffuser branches is the sum of airflows in each branch of the system:

$$Q_c = \sum_{j \in \{1,2\}} Q_j \quad (13)$$

The influence of temperature on the pressure in the main pipeline was modelled as:

$$p_c = p_b \frac{T_2}{T_1} \quad (14)$$

where T_1 – temperature of the pumped air at the input of the main pipeline [°C]; T_2 – temperature of the pumped air at the output of the main pipeline [°C].

Airflow in each branch of the aeration system is related to the air temperature:

$$Q_1 = \frac{T_3}{T_2} (p_c - \Delta p_{d,1}) \cdot \frac{1}{R_{g,1}}; Q_2 = \frac{T_4}{T_2} (p_c - \Delta p_{d,2}) \cdot \frac{1}{R_{g,2}} \quad (15)$$

where T_3 – temperature of the pumped air in the first branch of the system [°C]; T_4 – temperature of the pumped air in the second branch of the system [°C].

For the identification of the aeration system, a simplification of the model was performed. Because the values of parameters $R_{g,1}$ and $R_{g,2}$ are small and similar with each other, and the number of diffusers in each is similar, two diffuser systems were reduced to one. The scheme of the simplified model is presented in Fig. 4.

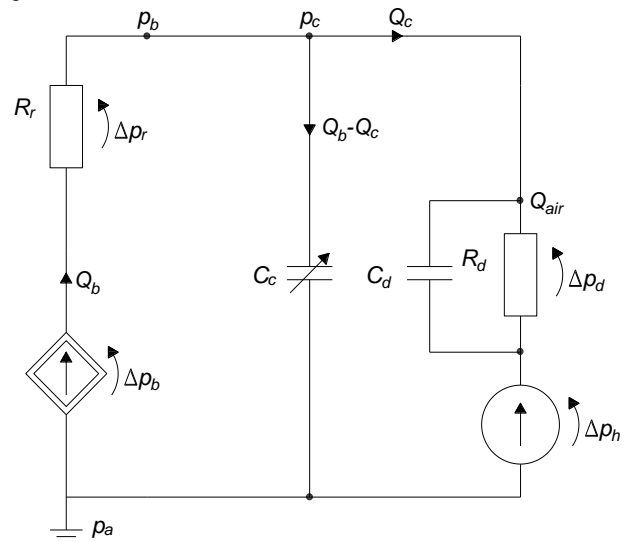

Fig. 4. Simplified aeration system model.

The parameters of the equivalent branch are as follows:

$$C_d = C_{d,1} + C_{d,2} \tag{16}$$

$$Q_{air} = Q_{air,1} + Q_{air,2} = a_d \cdot (k_1 \Delta p_{d,1} + k_2 \Delta p_{d,2}) \tag{17}$$

$$\Delta p_{d,1} = \Delta p_{d,2} = \Delta p_d \tag{18}$$

where a_d – slope of the diffuser’s characteristic [-]; k_1, k_2 – number of diffusers in the first branch and the second branch, respectively [-].

Given Eqs (17) and (18):

$$Q_{air} = a_d \cdot (k_1 + k_2) \cdot \Delta p_d \tag{19}$$

The equivalent airflow resistance R_d is

$$\frac{1}{R_d} = \frac{1}{R_{d,1}} + \frac{1}{R_{d,2}} = \frac{Q_{air}}{\Delta p_d} = a_d \cdot (k_1 + k_2) \tag{20}$$

The final form of the simplified model of the aeration system consists of the model of the blower, Eqs (6) and (7) and equations:

$$\frac{d\Delta p_d}{dt} = \frac{Q_b}{C_c + C_d} - \frac{\Delta p_d}{R_d(C_c + C_d)} \tag{21}$$

$$C_d = \frac{1000 \cdot V_d}{R_m \cdot T_d}; V_d = \frac{1}{4} \pi d_d^2 l_d \tag{22}$$

where R_m – gas constant [J·m⁻³·K⁻¹].

The aeration system model was implemented in the Matlab environment and verified based on the results of the simulation tests. The results were compared with data from the case study WWTP in Swarzewo. Because the results were satisfactory, the model was applied to the considered control system.

3. CONTROL SYSTEM DESIGN

The biological wastewater treatment processes in an SBR are non-linear complex processes. Therefore, designing a control system for it is not a trivial research task. However, it may be approached by decomposing the system into subsystems with different time constants. Then it is possible to apply a hierarchical control system with an upper-level controller (supervisory controller) and a lower-level controller (see Fig. 5).

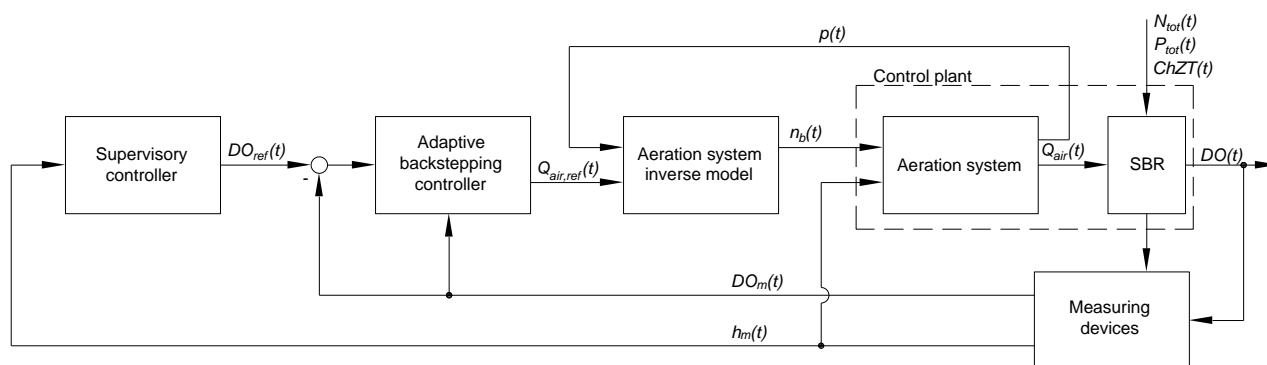

Fig. 5. Scheme of the novel control system

The supervisory controller is responsible for specific phase order in the SBR and the predefined duration of each phase. The input variable of the supervisory controller is the level of wastewater in the reactor $h(t)$. Based on it, the duration of the filling phases is determined. In the filling phases, the reactor is filled to a specified level. The output of the controller is the state vector, which determines the state (on/off) of the following utilities or stages of the SBR work cycle: pumps responsible for the inflow of wastewater to the SBR, stirrers, blowers, decantation and excess sludge pumps. The order of the phases applied in the supervisory controller is given in Table 1.

Tab. 1. Phases in the SBR’s cycle in the supervisory controller

No.	1	2	3	4	5	6	7	8	9	10	11	12
Phase	First anaerobic	First anaerobic/ filling	First aerobic	Second anaerobic	Second anaerobic/ filling	Second aerobic	Third anaerobic	Third anaerobic/ filling	Third aerobic	Sedimentation	Decantation	Excess sludge removal

Based on the phase of the SBR cycle, the supervisory controller generates a control signal, which is the reference value of the DO concentration $DO_{ref}(t)$.

An inverse model of the aeration system was derived to find the control variables of the aeration system. In order to acquire the inverse model, the model described in the literature [19] was used. The output variable of the inverse model is $n_b(t)$ – which is a relative (to the characteristic velocity) rotational speed. The input variables of the inverse model are the reference value of airflow $Q_{air,ref}(t)$, which is calculated by the DO concentration controller and the pressure present in the aeration system $p(t)$.

The $n_b(t)$ is determined based on the matrix of characteristic velocities, the matrix of blower characteristic airflows and the matrix of blower characteristic pressures.

Limitations, such as modelling the overheat and the surge of the blower, were included in the inverse model. The equations of the limitations are:

$$p_1(t) = 0.0094 \cdot Q_{air,ref}(t) + 0.8792 \tag{23}$$

$$p_2(t) = 0.0205 \cdot Q_{air,ref}(t) - 36.1888 \tag{24}$$

$$p_3(t) = 0.0094 \cdot Q_{air,ref}(t) - 12.6264 \tag{25}$$

where $p_1(t), p_2(t)$ and $p_3(t)$ are pressure limit functions.

The overheat limitation is active if the pressure in the aeration system $p(t) < p_1(t)$ or if $p(t) < p_2(t)$. The surge limitation is active if $p(t) > p_3(t)$.

By considering the limitations, the characteristics of the blower were obtained (see Fig 6).

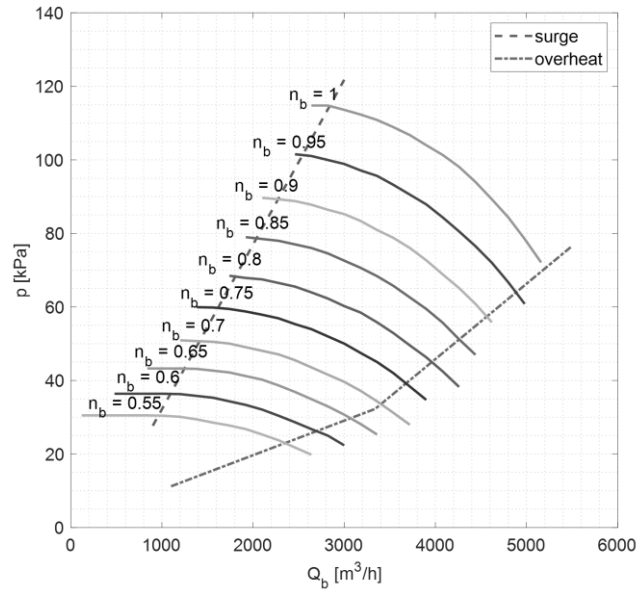

Fig. 6. Characteristics of the blower

The model of DO concentration (1)–(2) is a parametric, dynamic, non-linear, deterministic and continuous lumped-parameter model. The parameter $R(t)$ introduces uncertainty and time invariance to the model, thus significantly complicating the task of designing a controller for the process. The scheme of the DO concentration control system is shown in Fig. 5.

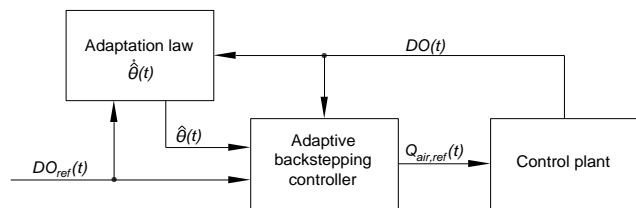

Fig. 5. Scheme of DO concentration control system

In the role of the DO controller, the adaptive backstepping algorithm was applied. It is a recursive method, which allows to achieve a globally stable control system for non-linear dynamic systems, as it ensures a solution for control and tracking problems. The method is based on a mathematical model and is used primarily for cascade systems. At every step of the design process, a stable control law is achieved based on the Lyapunov function theorem. The classical backstepping method is used for designing a static feedback loop. However, if there are uncertainties in the system, which can be written as unknown, variable parameters, it is justifiable to use adaptive backstepping. It allows to design a dynamic feedback loop [20].

The disturbances in this control system are the total nitrogen $N_{tot}(t)$, the total phosphorus $P_{tot}(t)$ and the chemical oxygen demand $COD(t)$.

The control variable is the reference value of airflow: $u(t) = Q_{air,ref}(t)$. The unknown parameter is respiration: $\theta(t) = R(t)$.

As the first step of the backstepping procedure, the control error variable $e_c(t)$ was defined as a deviation of the control variable from its reference value:

$$e_c(t) = DO(t) - DO_{ref}(t) \tag{26}$$

where $e_c(t)$ – control error.

The derivative of the control error was obtained:

$$\frac{de_c(t)}{dt} = \frac{dDO(t)}{dt} - \frac{dDO_{ref}(t)}{dt} = -\frac{DO(t)}{DO(t)+K_{DO}} \cdot \theta(t) + \alpha \cdot (DO_{sat} - DO(t)) \cdot u(t) - \frac{dDO_{ref}(t)}{dt} \tag{27}$$

where $\theta(t)$ – unknown parameter [g O₂/m³ h].

The following control law was proposed:

$$u(t) = \frac{1}{\alpha(DO_{sat}-DO(t))} \left(ke_c(t) - \frac{DO(t)}{DO(t)+K_{DO}} \theta(t) - \frac{dDO_{ref}(t)}{dt} \right) \tag{28}$$

where k – controller parameter [1/h], $k > 0$.

The parameter $\theta(t)$ is unknown, thus it was substituted with its estimated value $\hat{\theta}(t)$. Given this change, the control law Eq. (8) takes the form:

$$u(t) = \frac{1}{\alpha(DO_{sat}-DO(t))} \left(ke_c(t) - \frac{DO(t)}{DO(t)+K_{DO}} \hat{\theta}(t) - \frac{dDO_{ref}(t)}{dt} \right) \tag{29}$$

Given Eqs (7) and (9), the following equation was obtained:

$$\frac{de_c(t)}{dt} = -ke_c(t) - \frac{DO(t)}{DO(t)+K_{DO}} \cdot (\theta(t) - \hat{\theta}(t)) \tag{30}$$

Lyapunov function was proposed:

$$V(e_c) = \frac{1}{2} e_c^2(t) + \frac{1}{2\gamma} \cdot (\theta(t) - \hat{\theta}(t))^2 \tag{31}$$

where γ – adaptation mechanism parameter [-].

Its derivative is:

$$\frac{dV(e_c)}{dt} = e_c(t) \cdot \frac{de_c(t)}{dt} + \frac{1}{\gamma} \cdot (\theta(t) - \hat{\theta}(t)) \cdot \hat{\theta}(t) \tag{32}$$

Substituting $\frac{de_c(t)}{dt}$ in Eq. (32) with Eq. (28):

$$\frac{dV(e_c)}{dt} = -ke_c^2(t) - (e_c(t) \cdot \frac{DO(t)}{DO(t)+K_{DO}} + \frac{1}{\gamma} \cdot \frac{d\hat{\theta}(t)}{dt}) \cdot (\theta(t) - \hat{\theta}(t)) \tag{33}$$

The following adaptation law was proposed:

$$\frac{d\hat{\theta}(t)}{dt} = -\gamma \cdot e_c(t) \cdot \frac{DO(t)}{DO(t)+K_{DO}} \tag{34}$$

Finally:

$$\frac{dV(e_c)}{dt} = -ke_c^2(t) < 0 \tag{35}$$

Hence, the Lyapunov function's derivative is negative definite, thus it guarantees asymptotic convergence of the control error $e_c(t)$ to zero.

4. RESULTS AND DISCUSSION

The simulation results of the control system designed in Section 3 are shown in Fig. 7. Full work cycle of the SBR is presented. The cycle includes three aerobic phases with a predetermined duration. During these phases, the aeration system and the DO controller are activated. Outside aerobic phases, the DO controller is turned off, which means that the control signal $Q_{air,ref}(t)$ (Fig. 7b) is set as zero.

DO(t) was compared with its reference trajectory in Fig. 7a. Due to the time variance of the control plant and the influence of disturbances, the trajectory of DO(t) in each aerobic phase differs. The achieved rise time of DO(t) was within the range of 3.73–4.23 min and it was satisfactory. The shortest rise time was achieved for the second aerobic phase and it was approximately 3.73 min. The longest rise time was achieved for the third aerobic phase and it was approximately 4.23 min. Following the overshoot at the beginning of each aerobic phase, DO(t) is maintained within an acceptable control error value, as the control error does not exceed 2.5% of the reference value. The ‘noise’ in the DO(t) signal in a steady state is a result of the aeration system’s action. The control signal $Q_{air,ref}(t)$ (Fig. 7b) assumes negative values, although it is not physically achievable. However, in the aeration system inverse model, the negative values of $Q_{air,ref}(t)$ are set as zero; thus it does not affect the functioning of the control system. The trajectory of $Q_{air}(t)$, which is the output of the aeration system, is shown in Fig. 7c. The values assumed by $Q_{air}(t)$ are as expected, which shows that the control system has been designed correctly.

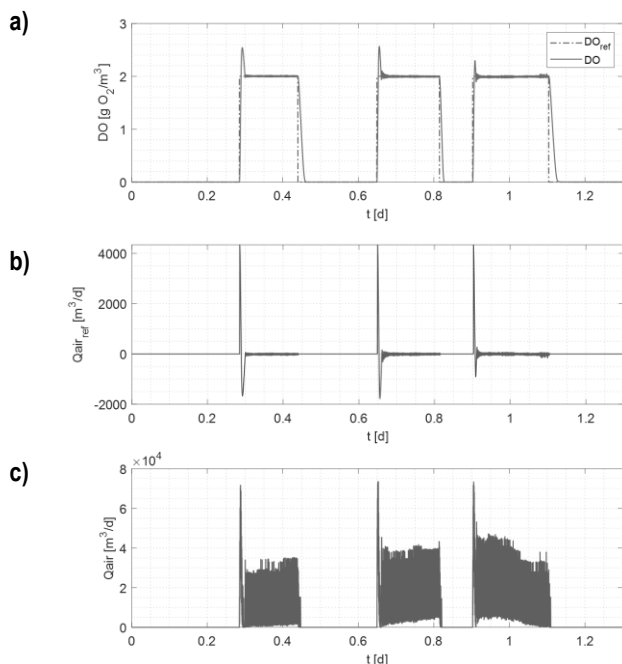

Fig. 7. Control results for constant DOfref trajectory; a) dissolved oxygen; b) reference airflow trajectory; c) airflow rate

An analysis of the algorithm for a variable DO trajectory was also carried out (Fig. 8). It was assumed that in the first phase the wastewater is under-oxygenated therefore an increased DO reference value was used, while in the third phase, the DO value was reduced, due to the pre-oxygenation in the previous phases.

Overall, the obtained results highlight the successful implementation of the DO control strategy. The control system demonstrated

its capability to achieve high-quality control performance for both variable and constant setpoint trajectories, ensuring the desired DO levels are maintained with accuracy and stability. These findings contribute to the understanding of the effectiveness of the control algorithm in practical applications and provide valuable insights for future process optimisation and control improvements.

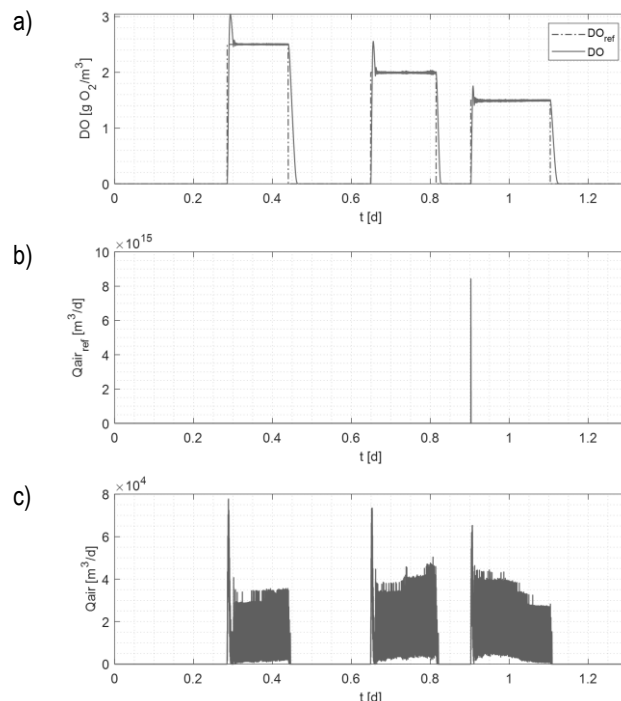

Fig. 8. Control results for variable DOfref trajectory; a) dissolved oxygen; b) reference airflow trajectory; c) airflow rate

Rapid attainment of the desired DO value is crucial in maintaining the proper duration of the phase. Microorganisms rapidly consume the supplied oxygen, making the speed of reaching the setpoint more important in the context of reactor conditions than the occurrence of overshoot.

5. CONCLUSIONS

In this paper, a novel approach to designing a controller tracking the reference trajectory of DO concentration was presented. A hierarchical control system with an adaptive backstepping controller as the lower-level controller was designed. Simulation tests of the control system were performed based on real data from the Swarzewo WWTP and the properties and performance of the control system were assessed. A good tracking performance was achieved. The results obtained for the fixed and variable DO reference trajectory are satisfactory. The control error does not exceed 2.5% of the reference value, and a near-zero steady-state deviation was obtained for each oxygen phase in both cases. Furthermore, in addition to good control performance, the presented algorithm has low computational complexity and adaptability to ensure control robustness.

The next step of this research will be designing and implementing an optimal supervisory controller, which allows to achieve an appropriate quality of cleared wastewater while maintaining minimal operational costs of the WWTP.

“Financial support of these studies from Gdańsk University of Technology by the DEC-3/2022/IDUB/III.4.1/Tc grant under the Technetium Talent Management Grants – ‘Excellence Initiative – Research University’ program is gratefully acknowledged”

REFERENCES

- Riffat R, Husnain T. *Fundamentals of Wastewater Treatment and Engineering*. 2nd ed. London: CRC Press; 2022.
- Khan AH, Rudayni HA, Chaudhary AA, Imran M, Vambol S. Modern use of modified Sequencing Batch Reactor in wastewater Treatment. EQ [Internet]. 2022 Jul. 11 [cited 2023 Jan. 25];33(4):1-23.
- Pittoors E, Guo Y, Van Hulle SWH. Modeling Dissolved Oxygen Concentration for Optimizing Aeration Systems and Reducing Oxygen Consumption in Activated Sludge Processes: A Review. *Chemical Engineering Communications*. 2014;201(8): 983-1002.
- Olsson G, Rundqwist L, Eriksson L, Hall L. Self-Tuning Control of the Dissolved Oxygen Concentration in Activated Sludge Systems. *Instrumentation and Control of Water and Wastewater Treatment and Transport Systems: Proceedings of the 4th IAWPRC Workshop Held in Houston and Denver, U.S.A., 27 April – 4 May 1985*. Pergamon Press Ltd. 1985:473-480.
- Holmberg U. Adaptive Dissolved Oxygen Control and On-Line Estimation of Oxygen Transfer and Respiration Rates. *Department of Automatic Control*. Lund Institute of Technology; 1987.
- Nejjari F, Khoury B, PuigV, Quevedo J, PascualJ, de Campos S. Economic Linear Parameter Varying Model Predictive Control of the Aeration System of a Wastewater Treatment Plant. *Sensors*. 2022;22(16):6008.
- Sheik AG, Seepana MM, Ambati SR. Supervisory control configurations design for nitrogen and phosphorus removal in wastewater treatment plants. *Water Environ Res*. 2021;93(8):1289-1302.
- Piotrowski R. Supervisory fuzzy control system for biological processes in sequencing wastewater batch reactor. *Urban Water Journal*. 2020;17:325-32.
- Man Y, Shen WH, Chen XQ, Long Z, Corriou, JP. Dissolved oxygen control strategies for the industrial sequencing batch reactor of the wastewater treatment process in the papermaking industry. *Environmental Science-Water Research & Technology*. 2018;4(5):654–662.
- Du X, Wang J, Jegatheesan V, Shi G. Dissolved Oxygen Control in Activated Sludge Process Using a Neural Network-Based Adaptive PID Algorithm. *Applied Sciences*. 2018;8(2):261.
- Nguyen A, Taniguchi T, Eciolaza L, Campos V, Palhares R, Sugeno M. *Fuzzy Control Systems: Past, Present and Future*. *IEEE Computational Intelligence Magazine*. 2019; 14(1): 56-68.
- Khatri N, Khatri KK, Sharma A. Enhanced Energy Saving in Wastewater Treatment Plant using Dissolved Oxygen Control and Hydrocyclone. *Environmental Technology & Innovation*. 2020; 18: 100678.
- Bai K, Jiang G, Jiang G, Liu Z. Based on fuzzy-approximation adaptive backstepping control method for dual-arm of humanoid robot with trajectory tracking. *International Journal of Advanced Robotic Systems*. 2019;16(3).
- Chaabane H, Djalal Eddine K, Salim C. Sensorless back stepping control using a Luenberger observer for double-star induction motor. *Archives of Electrical Engineering*. 2019;69(1):101-116.
- Henze M, Gujer W, Mino T, Matsuo T, Wentzel MC, Marais GVR, Van Loosdrecht MC. *Activated sludge model no. 2d*, ASM2d. *Water science and technology*. 1999;39(1):165-182.
- IFAK Technology, Simba. user's Guide. <https://www.ifak.eu/en/produkte/simba>. Accessed: 2023-01-10.
- Olsson G, Newell R. *Wastewater treatment systems. Modelling, diagnosis and control*. London: IWA Publishing; 1999.
- Piotrowski R, Brdys MA, Konarczak K, Duzinkiewicz K, Chotkowski W. Hierarchical dissolved oxygen control for activated sludge processes. *Control Engineering Practice*. 2008;16(1):114-131.
- Piotrowski R, Ujazdowski T. Model of aeration system at biological wastewater treatment plant for control design purposes. *Proc. of the 20th Polish Control Conference – KKA'2020*. October 14-29, 2020, Łódź, Poland, (in:) Bartoszewicz A., Kabziński J., Kacprzyk J. (eds). *Advanced, Contemporary Control. Advances in Intelligent Systems and Computing*. Springer; 2020;1196:349-359.
- Witkowska A, Tomera M, Śmierczalski R. A Backstepping Approach to Ship Course Control. *International Journal of Applied Mathematics and Computer Science*. 2007;17(1):73-85.

Michał Kolankowski:  <https://orcid.org/0000-0003-4528-3449>

Michał Banach:  <https://orcid.org/0000-0002-7501-0436>

Robert Piotrowski:  <https://orcid.org/0000-0002-8660-300X>

Tomasz Ujazdowski:  <https://orcid.org/0000-0001-6679-2985>



This work is licensed under the Creative Commons BY-NC-ND 4.0 license.