

ENERGY – TIME METHOD FOR ASSESSMENT OF MAIN DIESEL ENGINE OPERATION

Jacek Rudnicki

*Gdansk University of Technology
Narutowicza 11/12 80-952 Gdansk, Poland
tel.: +48 58 3472973
e-mail: jacekrud@pg.gda.pl*

Abstract

This paper presents a development of the known qualitative method for assessment of engine operation, applied to ship main diesel engine as an example. According to this interpretation engine operation can be presented as a physical quantity. In this aspect, based on the selected functional system of the engine, was assessed usefulness of the quantity for description reliability features of the system. To the analysis was applied Poisson's uniform process which made it possible to elaborate a model of run of worsening the considered system's operation taken as a random process of identical independent decreases of energy efficiency within a given time interval. The presented method is a valuable supplement for description reliability features of ship main engine what is important for realization of shipping tasks by sea. Additional advantage is versatility which makes that it can be applied to reliability analysis of any ship device or ship energy subsystem.

Classification of the engine serviceability states with taking into account the assessment of its operation in energy-time aspect, schematic diagram of lubricating system of RTA48-TB engine and values of lubricating oil parameters in steady conditions for the engine load, graphical presentation of lubricating oil cooler operation graphical interpretation of the decreasing of oil cooler efficiency are presented in the paper

Keywords: *ship power plants, diesel engine performance, reliability*

1. Introduction

During time of operation of every power plant its subsystems are affected by various external and internal factors which cause irreparable degradation processes resulting in technical state changes and usually gradual worsening their operational characteristics. Hence in the subsystems failures of their components occur inevitably. In view of consequences of potential failures to recognize and describe the above mentioned processes in relation to main propulsion engine, becomes crucial. In the case of sea-going ship a change of main engine state to that belonging to the set of the undesirable states can result in a hazard not only to ship power plant itself but also to the whole ship which - in the extreme case of being disable to move and course-keeping in heavy weather conditions – may suffer serious sea accident including sinkage [4].

Dynamic development of sea transport, growing number of ships and sea traffic intensity as well as diversity of realized tasks create real danger for people and the environment. Scale of the hazard and its trends can be observed in many reports and analyses published by special worldwide organizations.

When causes of sea accidents are analysed, attracts attention the fact that about 20% of the ship accidents still result from failures of ship power plants despite observed technological development [8].

During operation of floating units direct and indirect users of their power plants permanently make decisions dealing with using and maintaining particular devices - especially those associated with propulsion system, aiming at obtaining normal situation, i.e. that in which their safe operation is possible.

Making one of decisions of the kind at a given time instant consists in choosing - out of those possible to be taken – that which can be considered the best. The making of such decision which is necessary to determine a rational operational strategy, namely a.o. to [3]:

- appropriate scheduling the tasks,
- assuring an appropriate level of ship’s safety,
- appropriate planning preventive maintenance operations,
- correct arranging back-up facilities for maintenance and repair (e.g. planning demand for spare parts),
- is possible if only many different information elements are taken into account, however such choice will be never correct without taking into account data and indices associated with reliability of so complex functional subsystem of power plant as propulsion system is, particularly its crucial element - main engine.

2. Operation of main propulsion diesel engine

Objective reliability assessment of any ship piston engine requires to apply a quantitative approach to the problem and to seek such its measures as to obtain most credible description of the engine feature.

When considering the notion of reliability of ship piston diesel engines attention should be paid to the following important fact. As from the point of view of engine’s user the most important is quality of performing a given task by the engine, the notion of reliability is inseparably associated with unambiguous description of the task in question. In other words an imprecise description of the task would make sense of determining engine’s reliability indices questionable and their values rather useless and operational decisions taken on their basis probably erroneous.

And, such precise description of task requires, apart from assumed conditions in which it will be executed, its time duration to be also determined. The problem is so much important that specificity of sea shipping tasks is as a rule associated with necessity of long-lasting functioning the ship mechanisms and devices.

This way, especially important becomes not only which is quantity of energy one is able to have at disposal making use of the main engine but also time in which it can be delivered. Apart from commonly used reliability indices, to consider operation of engine (its functional subsystems) in a quantitative approach determined simultaneously by energy and time seems to be sensible.

In this case the operation (D) within the time interval $[0, t]$ can be interpreted as a physical quantity determined by the product of the time-variable energy $E = f(t)$ and time t that can be generally described by the following relationship [4]:

$$D = \int_0^t E(\tau) d\tau. \quad (1)$$

In the case of general analysis of diesel engine’s operation it can be considered that the energy resulting from fuel oil combustion in engine cylinders makes it possible to produce torque of the engine. As a result of transmitting the torque from the engine to a consumer, is done the work L_e , that can be determined – in this case - from the relationship:

$$L_e = M_o \cdot 2\pi n \cdot t, \quad (2)$$

where:

- L_e - useful work,
- M_o - average torque of engine,
- N - rotational speed of engine.

The product $M_o \cdot 2\pi n$ which appears in the relationship (2) is of course the value of the effective power N_e developed by the engine during realization of a given transport tasks, whose



demanded value depends on type of the task and can be determined - on assumption of e.g. a given ship's speed –from the relationship [2]:

$$N_e = \frac{T \cdot (1-t) \cdot v}{\xi_K \cdot \eta_p \cdot \xi_{rot} \cdot \eta_{lw}}, \quad (3)$$

where:

- T – demanded value of thrust at assumed ship's service conditions and speed,
- v – ship speed,
- ξ_K – hull efficiency,
- ξ_{rot} – propeller rotational efficiency,
- η_p – free-propeller efficiency,
- η_{lw} – shaft-line efficiency.

In this case it results from the relationships (1), (2) that engine's operation can be determined by the following formula:

$$D = 2\pi \int_0^t M_0 n t dt. \quad (4)$$

By introducing the following notions to the further considerations:

- the required operation D_W , i.e. that necessary for realization of a given task (e.g. transport task, i.e. cargo shipping by sea within a given time period, which is equivalent to maintaining an average ship speed and - in consequence - power output developed by main engine (s),
- the possible operation D_M , i.e. that possible to be realized by the engine being in a given technical state and assumed functioning conditions,
- the criterion for serviceability level assessment in accordance with the principles shown in Fig. 1. can be obtained as a result of checking the following relationship [4]:

$$D_M \geq D_W. \quad (5)$$

In the design conditions ($L_M=L_W$, $t_M=t_W$) realization of the task of the duration time $t_{II} = t_W$ requires to obtain the operation value D' (Fig. 1).

Hence the task can be realized by the engine without any additionally limitations imposed on obtaining the value L_M and t_M located within the zone „II”. Theoretically in the zone „I” the task can be also realized as the value D' is reached, however it is obtained at satisfying the condition $L_M > L_W$, which means an impermissible overloading of the engine (or permissible but only within a given time period). Hence it can be deemed that from practical point of view the engine's operation value - at satisfying the conditions of the zone „I” – can be realized in the full serviceability state but only in exceptional circumstances (e.g. during exceptionally unfavourable weather conditions). And, in the zone „IV” the value D' is also available but for the time $t_{IV} > t_W$. If only such modification of the realized task can be considered possible the incomplete serviceability state of the engine can be accepted but under additional limiting conditions.

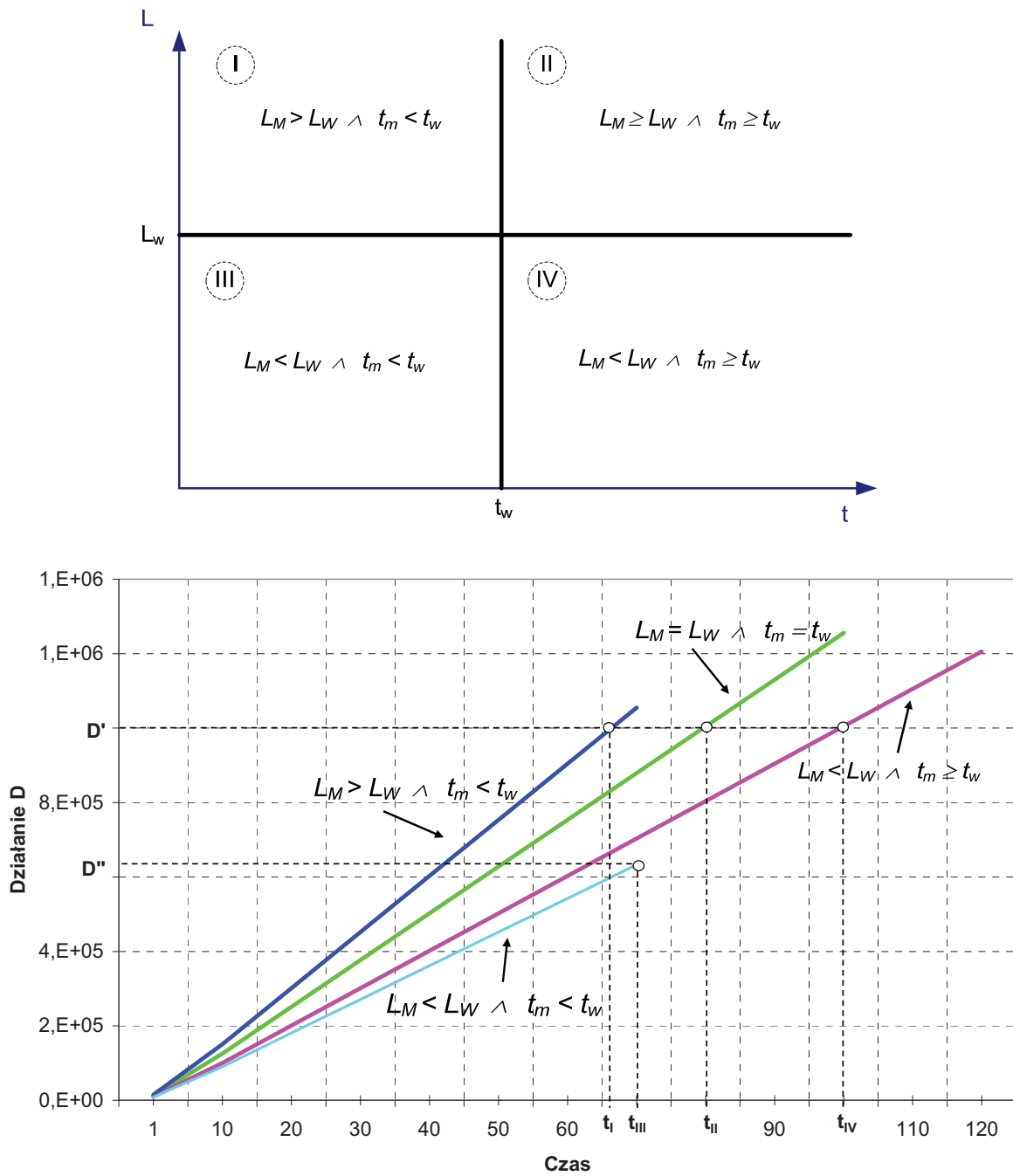

Fig. 1. Classification of the engine serviceability states with taking into account the assessment of its operation in energy-time aspect. L_w – value of required work, t_w – required duration time of operation, L_M – value of work possible to be done by the engine depending on e.g. its technical state, t_m – possible time of operation

3. Assessment of operation of a selected functional system of ship main diesel engine

The above presented approach to complex assessment of engine operation can be practically applied also to reliability assessment of its arbitrary structural unit or functional system in which energy transformation (or transmission) takes place.

An example solution of the considered problem is presented below for the case of analysis of operation of the lubricating oil cooling system. Out of the available engine operational data, 8RTA48-TB Wartsila diesel engine (of 11000 kW contract power output and 124 rpm rotational speed) was selected for simulative investigations [7]. The schematic diagram of the system in question is presented in Fig. 2.

For the selected steady state of 90% engine load the system in question is in the determined equilibrium condition resulting from the lubricating oil temperature $T_3=45^\circ\text{C}$ required by the engine's manufacturer, and measured at inlet to the engine.

In the presented system two elements: oil cooler (005) and thermostatic valve (006) operating in mixing system, play crucial role in maintaining the lubricating oil temperature at inlet, t_3 . All disturbances of heat exchange in the cooler (e.g. those resulting from contamination of heat exchange surfaces) result in changing the oil flow rates \dot{V}_1 and \dot{V}_2 . Within a given range of the disturbances thermostatic valve action compensates the abnormalities (by appropriate decreasing values of the flow rate \dot{V}_1 and appropriate increasing those of the flow rate \dot{V}_2), that is demonstrated by keeping values of the temperature t_3 on an assumed level.

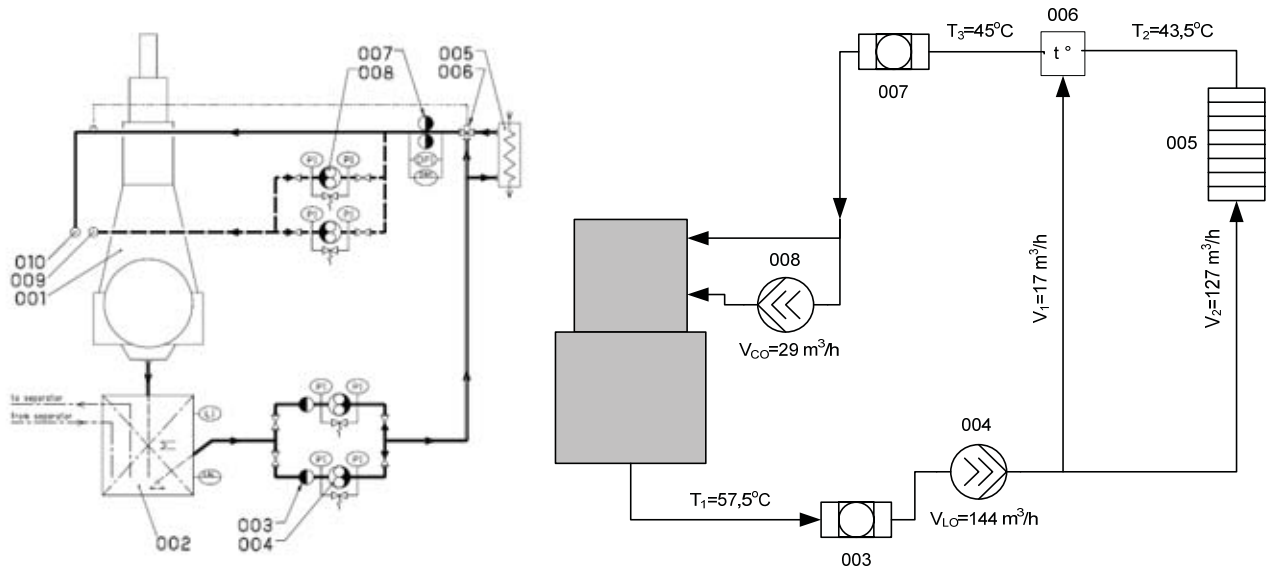

Fig. 2. Schematic diagram of lubricating system of RTA48-TB engine and values of lubricating oil parameters in steady conditions for the engine load $L = 90\%$. 001 – engine, 002 – circulating - sump tank of lubricating oil, 003 – circulating pump filter, 004 – circulating pump, 005 – lubricating oil cooler, 006 – thermostatic three-way valve, 007 – full-flow precise purification filter, 008 – lubricating pumps of crosshead bearings [6, 7]

The operation of oil cooler (as a heat exchanger) can be determined by the following relationship:

$$D_Q = \int_{t_1}^{t_2} m \cdot c \Big|_{T_1}^{T_2} \cdot (T_2 - T_1) dt = \int_{t_1}^{t_2} \dot{m} \cdot t \cdot c \Big|_{T_1}^{T_2} \cdot (T_2 - T_1) dt = \int_{t_1}^{t_2} \dot{V} \cdot \rho \Big|_{T_1}^{T_2} \cdot t \cdot c \Big|_{T_1}^{T_2} \cdot (T_2 - T_1) dt, \quad (6)$$

where:

m – mass of oil flowing through the cooler,

\dot{m}, \dot{V} – mass flow rate and volumetric flow rate of oil passing through the cooler, respectively.

$c \Big|_{T_1}^{T_2}$ – average specific heat of oil within the temperature range $T_1 - T_2$,

T_1, T_2 – oil temperature at inlet to and outlet from the cooler, respectively,

$\rho \Big|_{T_1}^{T_2}$ – average oil density in the temperature range of $T_1 - T_2$.

After substitution of appropriate values and under assumption that within the time period $[t_1, t_2]$ $Q = \text{idem}$ (constant engine load) the relationship (6) can be graphically presented as shown in Fig.3.

Along with passing time, the operational efficiency of the cooler decreases first of all due to degrading effects of lubricating oil and cooling water, which is defined as follows, will decrease.

$$\eta_{LOC} = \frac{Q_{O_{wc}}}{Q_{D_{LO}}}, \tag{7}$$

where:

$Q_{O_{wc}}$ – heat quantity absorbed by cooling water,

$Q_{D_{LO}}$ – heat quantity delivered by lubricating oil.

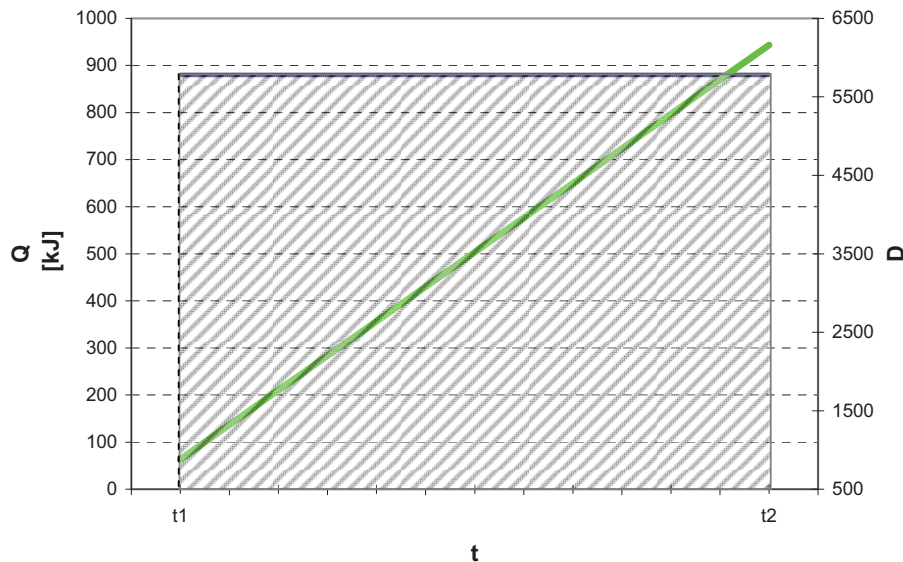

Fig. 3. Graphical presentation of lubricating oil cooler operation. Q – heat quantity exchanged within the cooler at constant engine load (90%), D – value of operation

The process of decreasing the energy efficiency of the cooler, presented in Fig. 4, depends mainly on process of its technical state change. In practice at partial load of engine within certain time interval the successive events U (occurring in the random instants t_1, t_2, \dots, t_n) which consist in decreasing (by a constant value Δq possible to be recorded) the heat quantity possible to be absorbed by cooling water, will not be signaled at all. It results from the control action of the thermostatic valve (item 006, Fig. 2) which will increase the flow rate \dot{V}_2 and simultaneously decrease the flow rate \dot{V}_1 . The situation will last until the condition $\dot{V}_1 = 0 \frac{m^3}{h}$ is satisfied. Every next occurrence of the event U will result in increasing the lubricating oil temperature at inlet to engine, T_3 .

The number $N_{\Delta q}$, of repetitions of the event U within the time interval $(0, t)$ is a random variable taking integer non-negative values. The time-dependent relation of the random variable is equivalent to the stochastic process $\{N(t) : t \geq 0\}$. Taking the assumptions [1] on its stationarity, lack of consequences and singularity of flow, one can apply the Poisson's uniform process [1, 5] to describe the process of decreasing the cooler's energy efficiency η_{LOC} (7), which results from $Q_{O_{wc}}$ decreasing.

Therefore, after occurrence of $N_{\Delta q}$ number of the events U up to the time instant t , the total decrease of the heat amount $Q_{O_{wc}}$ taking place up to the instant t can be presented as:

$$\Delta Q_{O_{wc}} = \Delta q \cdot N_{\Delta q}, \tag{8}$$

where:

$\Delta Q_{O_{wc}}$ - total decrease of $Q_{O_{wc}}$ after occurrence of $N_{\Delta q}$ events U,

Δq - elementary, possible to be recorded, amount of heat by which $Q_{O_{wc}}$ becomes smaller, and the random variable $N_{\Delta q}$ has the distribution [1]:

$$P(N_{\Delta q} = k) = \frac{(\lambda \cdot t)^k}{k} \exp(-\lambda t); \quad k = 1, 2, \dots, n, \quad (9)$$

where:

λ - constant considered as rate of occurrence of the event U ($Q_{O_{wc}}$ decrease by Δq quantity).

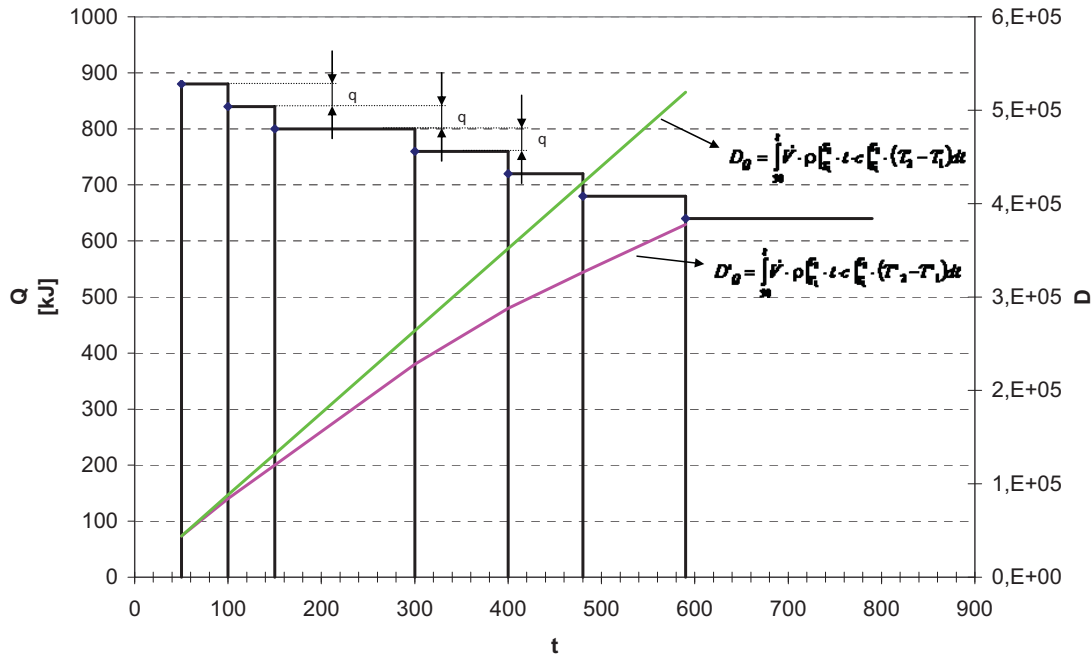

Fig. 4. Graphical interpretation of the decreasing of oil cooler efficiency. D_Q – nominal value of operation, D'_Q – real value of operation, T_1, T_2 – oil temperatures at inlet to and outlet from the cooler in conditions of non-disturbed heat exchange, respectively, T'_1, T'_2 – oil temperatures at inlet to and outlet from the cooler in conditions of worsened heat exchange due to change of technical state of the cooler, respectively

From practical point of view the determination of Δq and λ . values becomes crucial. It is possible in the case of satisfying two additional conditions:

- having at disposal results of service investigations performed with the use of standard control-measurement instrumentation of the considered system, as well as a system for diagnosing the considered process by recording and analyzing values of changes of flow rates \dot{V}_1, \dot{V}_2 within time intervals when engine's load maintains relatively constant,
- analysis of engine's technical documentation and carrying out simulative investigations which make it possible to elaborate a mathematical model of influence of occurring events U on operational parameters of the technical system in question.

In the presented case, Δq value was determined taking into account 0,5 accuracy class of the commonly applied flow-meters that made it possible to determine the value on the level of $\Delta q \approx 4,5$ kJ.

Because of lack of results of empirical investigations, λ value was determined by taking into account the following assumptions:

- drop of efficiency of heat exchanger by $\Delta \eta_{LOC} \approx 2,5\%$ triggers the directing of full flow of oil through the cooler (Fig. 2. $\dot{V}_1 = 0 \frac{m^3}{h}$) and any successive occurrence of the event U causes

- significant disturbances in correct operation of the system [6,7],
- duration time within which the $\Delta\eta_{LOC}$ value is obtained, estimated on the basis of the engine's technical documentation and producer's recommendations concerning performance of overhauls and repairs, amounts to $t_{\Delta\eta} = 20\ 000$ hours of engine operation [6,7].

Taking into account the above mentioned assumptions one can state that - within the above given time interval - about $N_{\Delta q} = 4,888$ of the events U occur, hence:

$$\lambda = \frac{N_{\Delta q}}{t_{\Delta\eta}} \approx 0,00024 \frac{1}{h}. \quad (10)$$

3. Conclusions

Making the assumption that for $t = 0$ the heat absorbed in the cooler is equal to : $Q_{O_{wc}}(0) = Q_{O_{wc} \max}$ and determining the expected value and standard deviation of the heat decrease up to the instant t as follows:

$$E[\Delta Q_{O_{wc}}(t)] = \Delta q \cdot E(N_{\Delta q}) = \Delta q \cdot \lambda \cdot t, \quad \sigma_Q = \Delta q \sqrt{D^2(N_{\Delta q})} = \Delta q \sqrt{\lambda t}, \quad (11)$$

one can find the relationship which describes the heat decrease $Q_{O_{wc}}$ within the time t [4]:

$$Q_{O_{wc}}(t) = \begin{cases} Q_{O_{wc} \max} & \text{for } t = 0 \\ Q_{O_{wc} \max} - \Delta q(\lambda t \pm \Delta q \sqrt{\lambda t}) & \text{for } t > 0 \end{cases}. \quad (12)$$

Making use of the formula (12) one can determine, for an arbitrary instant t , quantity of the heat $Q_{O_{wc}}$ which can be removed by the cooler, whereas the formula (9) makes it possible to determine probability of occurrence of such number of the events U which will cause necessity of additional limitations during realization of a given task (e.g. lack of possibility to arbitrarily load the engine within its working area), or make it impossible at all. Hence, the value of probability can be considered as that of reliability index.

In the author's opinion the presented method is a valuable supplement to the so far used ways of description reliability features of ship main engine being crucial element of ship power plant and ship itself. Its main advantage is the consideration of energy assessment in connection with time period in which a given task is realized. This is important for realization of shipping tasks by sea, which usually last long. Its additional advantage is versatility which makes that it can be applied to reliability analysis of any ship device or ship energy subsystem.

References

- [1] Bielajew, J. K., Gniedenko, B. W., Sołowiew, A. D., *Metody matematyczne w teorii niezawodności*, Wydawnictwa Naukowo – Techniczne, Warszawa, 1968.
- [2] Chachulski, K., *Podstawy napędu okrętowego*, Wydawnictwo Morskie, Gdańsk, 1988.
- [3] Fokin, G., *Niezawodność eksploatacyjna urządzeń technicznych*, MON, Warszawa, 1973.
- [4] Girtler, J., Kuzmider, S., Plewiński, L., *Wybrane zagadnienia eksploatacji statków morskich w aspekcie bezpieczeństwa żeglugi*, Wyższa Szkoła Morska w Szczecinie, Szczecin, 2003.
- [5] Smith D. J., *Reliability, Maintainability and Risk. Practical Methods for Engineers*, Butterworth –Heinemann Linacre House, Oxford, 2001.
- [6] *General Technical Data. WinGTD ver. 2.9*, Wärtsilä Switzerland Ltd, 2004.
- [7] *Sulzer RTA48T –B. Engine Selection and Project Manual*, Wärtsilä Switzerland Ltd, 2002.
- [8] <http://gisis.imo.org/Public/ISPS/Default.aspx>.