

Piotr LEŚNIEWSKI

GDANSK UNIVERSITY OF TECHNOLOGY, FACULTY OF ELECTRICAL AND CONTROL ENGINEERING,
HIGH VOLTAGE AND ELECTRICAL APPARATUS

Influence of the method of the control of the hybrid contactless short-circuit limiter on power quality

M.Sc. Piotr LEŚNIEWSKI

Was born in 1975 in Kwidzyn, Poland. He received M.Sc. degrees from the Gdansk University of Technology in 2000. At present, he is researcher at the Gdansk University of Technology. His field of interest are current limiters, computer analysis and power quality.



e-mail: p.lesniewski@ely.pg.gda.pl

Abstract

The paper is dedicated to control conditions of a hybrid contactless current limiter aimed at the efficient mitigation of voltage dips. Basic features of the limiter, as well as its control circuit have been described. Since the fault current is detected by operation of a special short fuse incorporated in the limiter the control has to be tuned to the prearcing and arcing times of the fuse dependent on actual current and circuit conditions. It has been demonstrated that the control system based on the across-fuse voltage measurement needs relevant fast-acting sensors. Effects of timing of the limiter control on the fault current limitation have been demonstrated.

Keywords: contactless hybrid current limiter, power quality, voltage dips.

Wpływ sposobu sterowania bezstykowego hybrydowego ogranicznika prądów zwarciovych na jakość energii

Streszczenie

W artykule przedstawiono wpływ sterowania bezstykowego ogranicznika prądów zwarciovych na ograniczanie spadków napięcia. Scharakteryzowano podstawowe własności ogranicznika oraz układu sterowania jego pracą. Ponieważ prąd zwarciovych jest detekowany przez dedykowany superkrótki bezpiecznik sterowanie musi być dostosowane do czasu przedrukowego i łukowego topika, które zależą od aktualnej wartości prądu i aktualnej konfiguracji obwodu. Pokazano, że układ sterowania oparty na pomiarze napięcia między zaciskami topika wymaga zastosowania bardzo szybkiego czujnika pomiarowego. Zaprezentowano wpływ doboru czasów sterowania ogranicznika na ograniczanie prądu zwarciovego.

Słowa kluczowe: łącznik hybrydowy, jakość energii, zapady napięcia.

1. Introduction

Since voltage dips [1] are defined as the mains voltage decrease leaving only from 1% to 90% of the declared voltage U_c , lasting from 10 ms to 1 min, a fast fault-current limitation and interruption turns out to be a basic tool for voltage dips mitigation and improvement of the quality of energy. Although voltage dips may be due to overcurrents of various provenience, e.g. large motor starting, transformer inrush currents i.e., short-circuit currents are the basic source of most serious distortions.

A contactless hybrid current limiter (CHCL) elaborated in the Gdansk University of Technology [2,3] belongs to current limiters practical for the mitigation of voltage dips. Its part responsible for the discrimination of a current faults is a special short fuse, which is sensitive to the Joule integral of passing fault current and the time of its duration. The control of the another part, the semiconductor switch, must be carefully carried out to ensure a fast fault-current limitation and the proper voltage strength of the fuse after its operation.

2. Design of the analyzed CHCL

A simplified diagram of CHCL is presented in Fig. 1. The CHCL is composed of three current paths in parallel: the short fuse (SF), the semiconductor switch (SS), and the metal oxide energy absorber (ZnO) [4, 5]. The SF carries load currents and ruptures under a fault current. It has no current breaking capacity. After the SF [6] operates, the SS must take the current over, wait until the SF gap deionises and force the current into ZnO, to bring it to zero. The SS switching operations are controlled by the control circuit (CC), which must carefully select adequate instants for SS operation depending on the SF state.

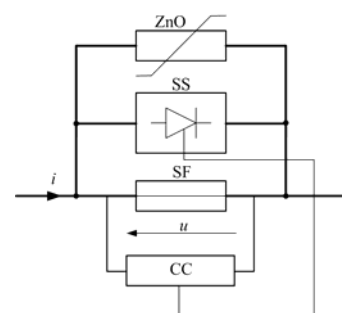

Fig. 1. Diagram of DC CHCL model [3]

Rys. 1. Schemat modelu CHCL prądu stałego [3]

In Fig. 2 simplified current and voltage curves of CHCL operation are shown. The above discussed characteristic times affected CHCL operation are marked.

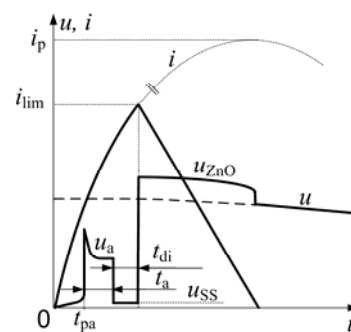

Fig. 2. Simplificated current and voltage curves of CHCL operation: t_{pa} – the prearcing time, t_a – the arcing time, t_{di} – the deionising time, i_{lim} – the current limited by CHCL, i_p – prospective fault current, u_{SS} – the SS let-through voltage, u_a – the arcing voltage

Rys. 2. Poglądowe przebiegi prądu i napięcia CHCL: t_{pa} – czas przedrukowy, t_a – czas łukowy, t_{di} – czas dejonizacji, i_{lim} – prąd ograniczony, i_p – spodziewany prąd zwarciovych, u_{SS} – napięcie przewodzenia SS, u_a – napięcie łukowe

Typical voltage and current traces of CHCL operation are shown in Fig. 3. They have been taken while testing the CHCL containing SF with a copper fuse-element, 0.13 mm in diameter. The experiments were carried out in an oscillatory LC circuit at the frequency of 480 Hz and the prospective short-circuit current of 2.0 kA. The application of the test current frequency achieving approximately ten power system frequencies helps in ensuring a high rate of the current rise and simultaneously its low peak value.

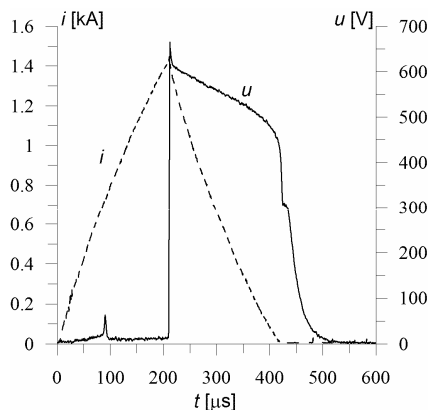

Fig. 3. Current and voltage records of the CHCL operation
Rys. 3. Przebieg prądu i napięcia podczas działania CHCL

3. Effect of the semiconductor element control on the operation of the CHCL

It is worth stressing that in contrast to typical semiconductor or hybrid current limiters, CHCL need not be equipped with current sensors, since the SF performs their role. The signal triggering SS is formed after the arc ignites in SF, which can be detected by watching the voltage across SF, or the light generated by the arc. The SS should only carry the current, as long as SF deionises. Any delay in current interruption results in the increase in the peak value of the limited current. So, an optimum CHCL operation must be carefully coordinated with SF operation, taking under consideration the required arcing- and deionisation times. Both of them vary with the current to be interrupted.

The fault duration, and the resulting voltage dip time (if the fault time is long enough) is a sum of the prearcing time t_{pa} , the arcing time t_a and the SF deionising time t_{di} . Only t_{pa} can be easily calculated followed the equation [7]

$$\int_0^{t_{pa}} i(t)^2 dt = S_z^2 \cdot K_M \quad (1)$$

where S_z is the fuse-element short-circuit cross-section area and K_M is the Meyer's constant.

The arcing time t_a should be long enough to ensure full decomposition of the fuse-element. Both times, t_a and t_{di} depend on current.

The signal triggering SS should be applied $t_{pa} + t_a$ after the short-circuit occurrence. If a voltage signal based on the arc ignition is used then SS switching on must only be delayed by t_a . The prearcing time t_a is evaluated by CHCL control unit, which measures the voltage appearing across SF up to the arc ignition. This makes the current limitation dependent on the voltage angle ψ at the instant of the short-circuit occurrence and power system features. The relationship between the angle ψ and the arc ignition time for a SF characterised by $S_z^2 \cdot K_M$ parameter $17.6 \text{ A}^2 \text{ s}$ is shown in Fig. 4.

In order to ensure the adequate recovery voltage strength of CHCL the SS should not be switched on until the whole fuse element has been decomposed. However, a prolonged arcing time leads to an excessive peak value increase of the limited current and to creation of a large volume of arc plasma, whose deionisation takes a long time.

The SS should not be switched off before SF has acquired its full electric strength that is associated with the time of current passing through SS. Switching off SS the fault current is forced into ZnO, and consequently brought to zero. One should also take under consideration the fact that an excessively increased current could not be controlled by the transistors of SS, what would bring about their thermal destruction.

Optimum arcing- and deionisation times are noted for a given SF and the interrupted fault current, which has been presented in the papers [8, 9]. For instance, it has been found that for a SF with the copper fuse-element, 0.13 mm in the diameter, the best current limitation conditions occur when the arcing time is about $10 \mu\text{s}$, and the deionisation time – $105 \mu\text{s}$. To fulfil these conditions the SS control must be precise, which requires reliable and accurate discrimination of the arc ignition.

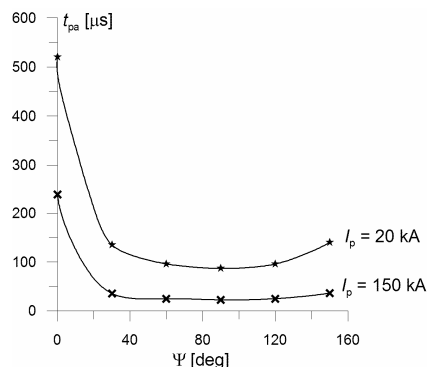

Fig. 4. Fuse arc prearcing time t_{pa} vs. voltage angle ψ at the instant of short-circuit occurrence: I_p - the prospective short-circuit current
Rys. 4. Czasu rozpadu topika t_{pa} w funkcji kąta fazowego napięcia ψ w chwili zwarcia: I_p - spodziewany prąd zwarcia

The triggering impulse can be formed based upon the light created by the arc, or upon the arcing voltage. The light signal provides the information slightly delayed in comparison to the arcing voltage, owing to the fact that the fast voltage increase across SF can be measured in advance of the arc ignition. Considered additionally the time of triggering impulse formation by CC and SF operation, it becomes clear that the application of light signals can unnecessary extend the fuse arcing time.

When the information relies on measurements of the voltage across SF, selection of the adequate method is crucial. Fast changing voltage, but low in comparison with the voltage forced by ZnO during the current limitation process, as well as the need for galvanic separation of the main and measurement circuits, limit the number of useful methods and sensors. The problem is presented in Fig. 5, in which signals provided by two different voltage probes (curve 2 and 3) are shown. A notably delayed SS triggering by the voltage signal provided by the probe (curve 3) can be noted. Relied upon the voltage measurement with voltage probe (curve 3), the SS would be switched on with a delay due to the probe characteristics comparable with the arcing time t_a . Such delay extends the fault time, increases the maximum value of limited current, and the probability of SF disruption.

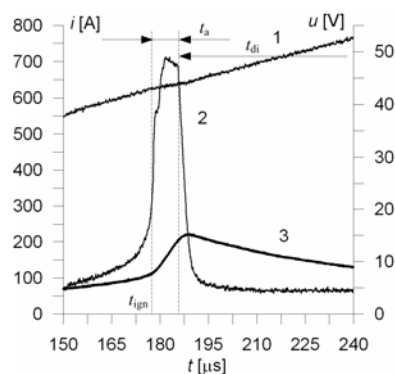

Fig. 5. Test current (1) and voltage across SF measured by means of different two voltage probes (curve 2 and 3)
Rys. 5. Pomiar prądu (1) oraz napięcia SS za pomocą dwóch różnych sond napięciowych (krzywa 2 oraz 3)

In Fig. 6, the effect of arcing time on the fault time and the limited current has been presented. The experiment was carried out in an oscillatory LC circuit, at the frequency of 488 Hz, and the prospective current of 1 kA. A copper fuse-element, 0.13 mm in the diameter was used.

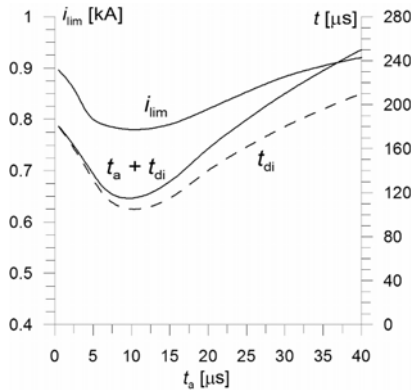

Fig. 6. Time of current limitation (t_a+t_{di}) and limited current (i_{lim}) vs. arcing time (t_a): t_{di} – deionisation time

Rys. 6. Czas do ograniczenia prądu (t_a+t_{di}) oraz prąd ograniczony (i_{lim}) w funkcji czasu łukowego (t_a): t_{di} – czas dejonizacji

In spite of the fact that the arcing time is only about 10% the total of time current limitation, its adequate control is very important since it influences the deionisation time and consequently – the value of limited current, and the fault duration.

Wrong the control of CHCL, eg. too early SS switching off, may provoke reignition in the SF, which dramatically extends the short-circuit time. Semiconductor switch must intervene, and current limitation, if still possible, is less effective. The possibility of the fast reclosing of the SS is a significant advantage of the CHCL. Such a case is demonstrated in Fig. 7, in which the arc reignition in SF, while interrupting 1.5 kA, at 488 Hz with 0.13-mm \varnothing copper fuse-element is shown.

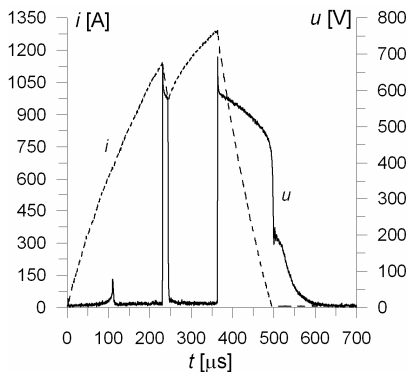

Fig. 7. Current and voltage records of the CHCL operation while the arc in SF reignition

Rys. 7. Przebiegi prądu i napięcia CHCL gdy wystąpił ponowny zapłon łuku w SF

4. Effect of CHCL on power quality

The above mentioned selection of the optimum timing of SS operation is not easy, because it must be associated not only with features of the SS, but with actual power system parameters as well. High power quality requires as short times as possible. However, the fuse-element disintegration and the arc deionisation take time proportional to the fault current being interrupted. In Fig. 8, results of simulations of the relationship between the limited current and the voltage angle at the instant of short circuit occurrence is presented for a variety of prospective short-circuit

currents. The calculations have been carried out for the arcing time $t_a = 10 \mu$ s and the deionisation time $t_{di} = 105 \mu$ s.

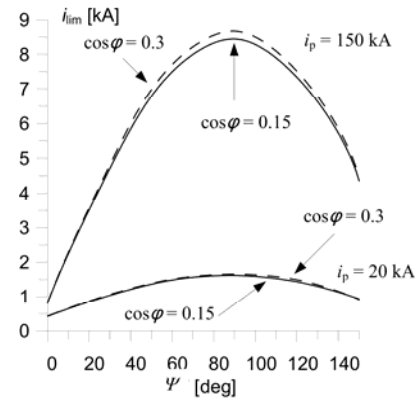

Rys. 8. Limited current i_{lim} vs. short-circuit making angle ψ : i_p – prospective current, $\cos \phi$ – power factor

Fig. 8. Prąd ograniczony i_{lim} w funkcji kąta fazowego napięcia ψ w chwili zwarcia: i_p – spodziewany prąd zwarcia, $\cos \phi$ – współczynnik mocy

The t - I characteristic of CHCL is very fast due to SF [4, 5]. Therefore, while selecting such current limiters, all overcurrents occurring in the power system and other circuit breakers settings should be taken under consideration. Although the operation of CHCL should be as fast as possible to mitigate voltage dips, high overcurrents and protection selectivity may require some delay.

Although the CHCL is a low voltage current limiter, its operation can also affect in some extend the distribution part of the system, which is schematically presented in Fig. 9.

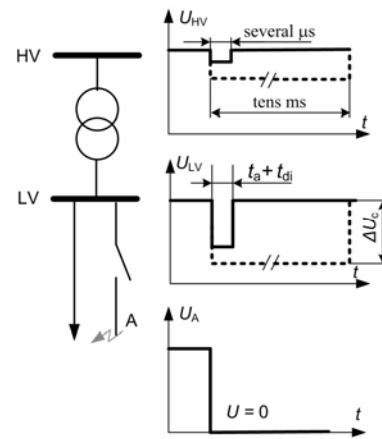

Fig. 9. Voltage dips mitigation by CHCL: dotted line – typical CB

Rys. 9. Ograniczanie zapadu napięcia za pomocą CHCL; linia przerywana – klasyczny łącznik zestykowy

5. Summary

Performance of CHCL depends heavily on the control of the inherent SS. Prolonged current conduction by the SS increases the peak value of the limited current, but on the other hand, too short current time of SS can bring about the reignition in the SF, further fault current rise and consequently – even SS destruction. There is an optimum of the arcing- and deionisation times defining the shortest process of current limitation.

For CHCL control based upon the measurement of the voltage across the fuse, the selection of the adequate measurement method is crucial. A wrong method can bring about a delay in the SS operation.

Fast current limitation and breaking by the CHCL can be used for the improvement of the quality of energy, due to the mitigation of voltage dips provoked by short-currents.

The research on contactless current limiting device has been carried out in the frames of the research project No: 3 T10A 059 27 financed by the Committee of Scientific Research in Poland.

6. References

- [1] PN-EN 50160:1998: Parametry napięcia zasilającego w publicznych sieciach rozdzielczych.
- [2] Wolny A., Semenowicz B.: Hybrid contactless short-circuit current limitation. 10-th International Symposium on "Short Circuit in Power Systems", Lodz, 28-29 October 2002.
- [3] Wolny A.: A new method of current limitation, Seventh International Conference of Electric Fuses and their applications, 8-10 September, Jurata 2003..
- [4] Wolny A., Semenowicz B., Leśniewski P: Features of a short fuse, as a main current path of a contactless hybrid current limiter. 10-th

International Symposium on "Short Circuit in Power Systems", Łódź, 28-29 October 2002.

- [5] Semenowicz B.: Bezpiecznik krótkotopikowy jako element bezstykowego hybrydowego ogranicznika prądów, Rozprawa doktorska (maszynopis), Gdańsk 2006.
- [6] Czucha J.: Arc ignition process in short fuse elements. Seventh International Conference of Electric Fuses and their applications, 8-10 September, Jurata 2003.
- [7] Lipski T.: Bezpieczniki niskonapięciowe, WNT Warszawa 1968.
- [8] Semenowicz B., Partyka R.: Dielectric strength of the ultra-short fuse, Seventh International Conference of Electric Fuses and their applications, 8-10 September, Jurata 2003.
- [9] Leśniewski P., Tlustochowicz Ł.: Wpływ sterowania ogranicznika prądów zwarciovych na jakość energii elektrycznej. Zeszyty naukowe Wydziału Elektrotechniki i Automatyki Politechniki Gdańskiej Nr 21, Gdańsk 2005.

Artykuł recenzowany

INFORMACJE

Studia Podyplomowe

Wydział Elektryczny Politechniki Śląskiej w Gliwicach
Instytut Metrologii, Elektroniki i Automatyki
ogłasza nabór na Dwusemestralne Zaoczne Studia Podyplomowe

Systemy Pomiarowe i Sterowniki Programowalne (SPSP)

Cel Studiów

Celem studiów jest przekazanie wiedzy teoretycznej i umiejętności praktycznych w zakresie: projektowania, wdrażania i utrzymania ruchu systemów automatyki, programowania sterowników PLC oraz systemów nadrzędnych (SCADA), projektowania, programowania i eksploatacji automatycznych systemów pomiarowych w laboratoriach badawczych i przemysłowych, metod opracowania danych w systemach zapewnienia jakości procesów przemysłowych.

Profil uczestnika studiów

Studia przeznaczone są dla pracowników o różnych specjalnościach, z wyższym wykształceniem o kierunku elektrycznym, elektronicznym, informatycznym lub pokrewnym, zajmujących się organizacją pomiarów w laboratoriach badawczych i przemysłowych lub eksploatacją oraz modernizacją systemów sterowania. Ich ukończenie pozwoli uczestnikom na podwyższenie kwalifikacji niezbędnych do sprawnego opracowywania i wdrażania nowoczesnych systemów. Absolwent Studiów otrzymuje Świadectwo Ukończenia Studiów Podyplomowych w zakresie objętym nazwą studiów.

Studia prowadzone są na Wydziale Elektrycznym Politechniki Śląskiej w Gliwicach, w systemie zaocznym w każdą sobotę lub w co drugi weekend (do wyboru) przez dwa semestry. Zajęcia prowadzone są przez nauczycieli akademickich ze stopniem co najmniej doktora oraz przez zaproszonych Gości o uznanym dorobku i autorytecie. Studia obejmują 200 godzin dydaktycznych. Rozpoczęcie Studiów nastąpi po skompletowaniu odpowiedniej liczby kandydatów na dany rodzaj studiów.

Warunki przyjęcia na studia:

1. Na studia mogą być przyjęte osoby posiadające dyplom magistra lub inżyniera, posiadające podstawową wiedzę z zakresu wybranych studiów.
2. Warunkiem uruchomienia studiów jest przyjęcie odpowiedniej liczby Kandydatów na podstawie złożonych dokumentów.
3. Dokumenty składane przez Kandydatów:
 - Kwestionariusz Osobowy – Karta Zgłoszenia (do pobrania ze strony internetowej). Przyjmowane na bieżąco: e-mailem, pocztą lub osobiście.
 - Kopia/odpis dyplomu ukończenia studiów wyższych.
4. Kandydaci odbywają rozmowę kwalifikacyjną. Termin ustalony i podany zostanie po skompletowaniu odpowiedniej liczby Kandydatów.
5. Po spełnieniu warunków Kandydaci wnoszą opłatę zgodnie z zawartą umową w wysokości 3 800 złotych za cały okres studiów.

Organizator studiów:

Instytut Metrologii, Elektroniki i Automatyki Politechniki Śląskiej, 44-100 Gliwice, ul. Akademicka 10, tel. 032 237 12 41, fax: 032 237 20 34, e-mail: re2@polsl.pl lub anna.kropka@polsl.pl, <http://www.wega.elekt.polsl.gliwice.pl>

Kierownik studiów:

Prof. dr hab. inż. Tadeusz SKUBIS

