

SOME PROBLEMS OF SLIDE BEARING MATERIAL FATIGUE EVALUATION

Jan Sikora, Jan Kłopotcki, Wojciech Majewski, Krzysztof Kurzych

Technical University of Gdańsk
Mechanical Engineering Faculty
Narutowicza 11/12, 80-952 Gdańsk, Poland
tel. +48 58 3471844, 3471844, 3090462, fax +48 58 3472742,
e-mail: jsikora@pg.gda.pl, jklopocki@pg.gda.pl, kkurzych@neostrada.pl

Abstract

A slide bearing alloy resistance against fatigue failures have been investigated for three different lubricants, different heat loadings and different stress ratio κ values. The research methods and data handling procedures for determination of particular parameter effects on fatigue strength have been described and analysed for experiments that were set and performed in laboratory tester SKMR-2. Main and interaction effects of lubricant and stress ratio factors on bearing material fatigue strength have been analysed.

Design scheme of the SKMR-2 head unit, Standard tested half-bearing, fatigue failures on the surface of the specimen, cross-section through the damaged surface layer of the specimen, fatigue limit stress amplitude vs. temperature and kind of oil, main effect of stress ratio, main effects of temperature and oil are illustrated in the paper.

Main conclusions are cover in statements that fatigue strength of the bearing material is affected, to the highest degree, by the mechanical stress value and stress ratio and resistance to the fatigue cracks is being reduced for higher tensional stress, increase in temperature is resulting in decreasing of the fatigue strength rating values, fatigue strength of the slide layer is considerably dependent on the type of the used lubricant interactions of the type of the lubricants, their temperatures, loading stress ratio have been noticed.

Keywords: bearings, tribology, bearing testing, fatigue investigations, fatigue performance

1. Introduction

Fatigue resistance of the dynamically loaded journal bearings can be understood as a local load-carrying capacity of slide layers, specified for assumed numbers of mechanical and heat loading cycles, in conditions of possible lubricant physic-chemical effects. Because of complexity of the fatigue processes, the fatigue strength for such a bearing can be practically determined only by experimental investigation. In ISO 7905 standard [1] (introduced to engineering practice in 1995) the system of test stands, including simple material investigation units as well as the complete arrangement of bearing units, are proposed. On the basis of investigation of the bearings or bearing materials the different parameters more or less adequate for defining the fatigue can be selected as indicators of reaching the fatigue critical state. The best description of the process is probably precise determination of complex stress distribution in the slide layer of the bearing bush.

2. Experimental investigations

Fatigue tests, that were aimed especially at the bearing material properties evaluation, were performed in SKMR-2 test rig [2] (Fig.1) for the half-bearing shell having the slide layer made of AlSn11,3Cu1. Nominal total bush wall thickness was 1,825 mm, while lining thickness was about 0,39 mm. Surface roughness $R_a=20\mu\text{m}$. A fatigue test base was taken as $3,6 \times 10^6$ loading cycles.

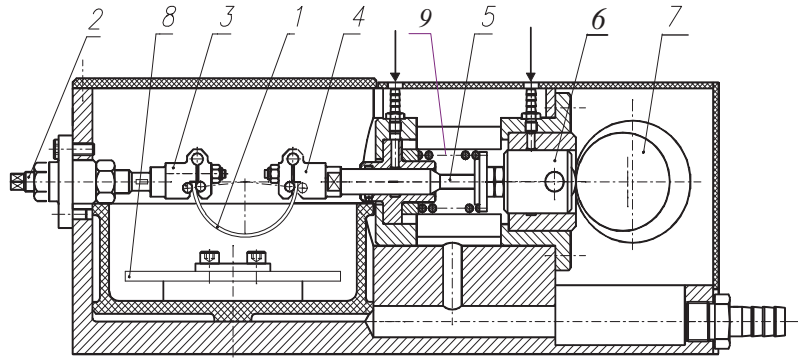

Fig. 1. Design scheme of the SKMR-2 head unit; 1 - specimen, 2 - adjusting screw, 3 - specimen fixture (dynamometer), 4 - movable specimen fixture, 5 - pusher, 6 - roll follower, 7 - eccentric, 8 - heater, 9 - compression spring

The tested sample (thin-walled half bearing - Fig. 2), was kept in two fixing elements: 3 - being stationary and 4 - oscillating due to reciprocating movement of pusher 5 and follower 6 forced by rotation of the shaft with adjustable eccentric 7 and by compression spring 9. In the result a loading of the specimen could change from tension to compression. A rotational speed of the shaft was 2100 rpm. During the test a specimen was immersed in the lubricant of controlled temperature.

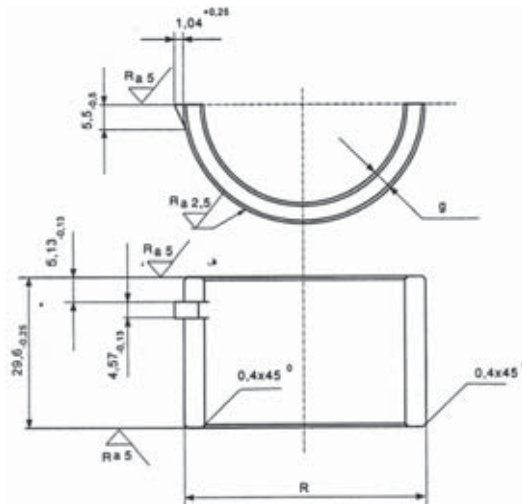

Fig. 2. Standard tested half-bearing

The tests with the bending loadings of the load (stress) ratios $\kappa = \sigma_m/\sigma_a$ equal (-1), (+1) or (0) and temperatures: 25°C, 80°C or 120°C were performed in the SKMR-2 tester. Appearance of the fatigue cracks or scratches on the bearing material layer was recognized as the critical fatigue state related to assumed numbers of loading cycles, with the given stress ratio and temperature. Fatigue test sequence was arranged according to the *two point strategy* [3] in experiment planning and results were elaborated with corresponding formalized method of data processing.

3. Stresses in the bearing shell

The number of fatigue tests for each fixed set of parameters was equal 14. After completing the test, for each specimen the surface state was examined and standard measurements have been taken.

The specimen was classified as damaged when the net of cracks on the inner surface of slide

layer at the region of maximum normal bending stress have appeared. The step between neighbouring stress levels was dependent on possible accuracy of adjusting the eccentricity of the shaft disc (no 7, Fig.1) that forced a stroke displacement (affecting the shell bending loadings).

The first test was performed for loading setting that is corresponding to expected critical loading value, while the next was fixed to the *two-point strategy* principle.

In the Fig. 3 the view of fatigue crack net observed on the slide layer (covered with the special penetrating substance) in the region of maximum bending stresses are presented. The cross-section through the layer is shown in the Fig. 4.

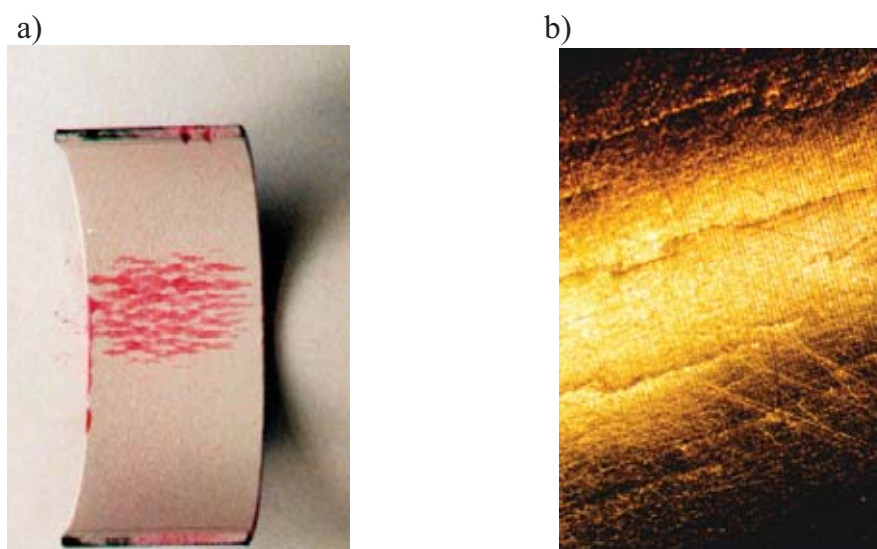

Fig. 3. Fatigue failures on the surface of the specimen; a – after application of dye penetrating substance, b – microscopic view of the surface (25× enlargement)

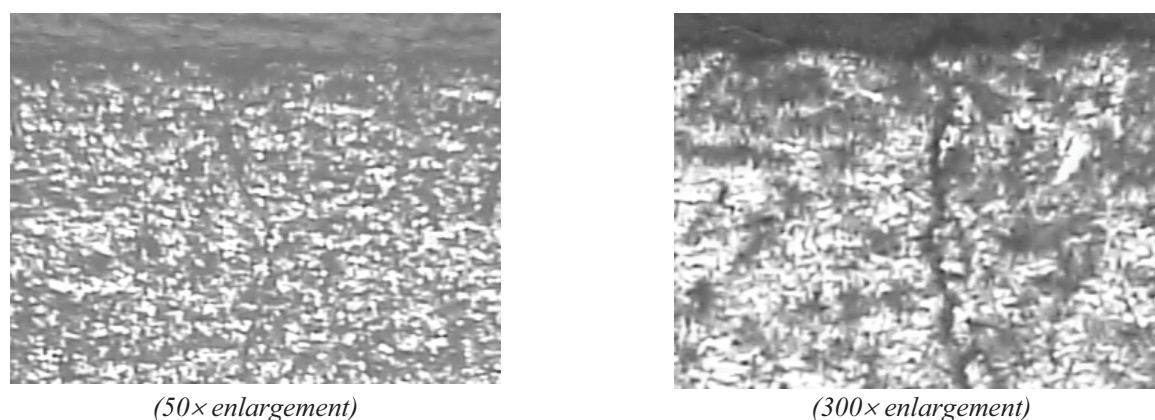

Fig. 4. Cross-section through the damaged surface layer of the specimen

Final results were worked out according to the applied strategy basing on investigation results and calibration of the SKMR-2 tester [4]. The achieved fatigue strength ratings $S_{0.50}$ (corresponding to the medians of investigated random variables) are presented in Tab.1. Standard deviations s of the populations of test results corresponding to the given combination of research factors are specified in parenthesis.

Data in the Tab.1 are allowing to estimate the influence of mechanical and heat loading as well as type of the lubricant on the resistance against fatigue for the AlSn11,3Cu1 bearing material investigated in tester SKMR-2. From the distribution of these values some tendencies are visible which can be learned by graphic analysis as e.g. in the Fig. 5 (loading for $\kappa = -1$ and different kind of lubricants and the temperature values).

Tab. 1. Fatigue strength rating $S_{0.50}$ [MPa] for slide layer AlSn11,3Cu1

Stress ratio	Oil	Temperature [$^{\circ}$ C]		
		25 $^{\circ}$	80 $^{\circ}$	120 $^{\circ}$
$\kappa = 1$	Basic oil	57,8 (1,71)	48,73 (2,26)	42,68 (1,10)
	Selektol	60,6 (1,95)	47,14 (1,15)	36,40 (1,21)
	Lotos Dynamic	59,7 (1,69)	47,55 (1,15)	38,47 (1,40)
$\kappa = 0$	Basic oil	88,6 (2,23)	76,10 (2,12)	70,05 (1,60)
	Selektol	86,0 (2,17)	74,67 (1,50)	67,61 (1,00)
	Lotos Dynamic	75,6 (2,26)	67,22 (1,37)	61,27 (1,82)
$\kappa = -1$	Basic oil	77,8 (1,22)	74,43 (1,90)	68,38 (1,36)
	Selektol	78,7 (1,48)	73,92 (0,96)	70,54 (1,12)
	Lotos Dynamic	74,8 (2,10)	70,56 (1,50)	67,73 (1,37)

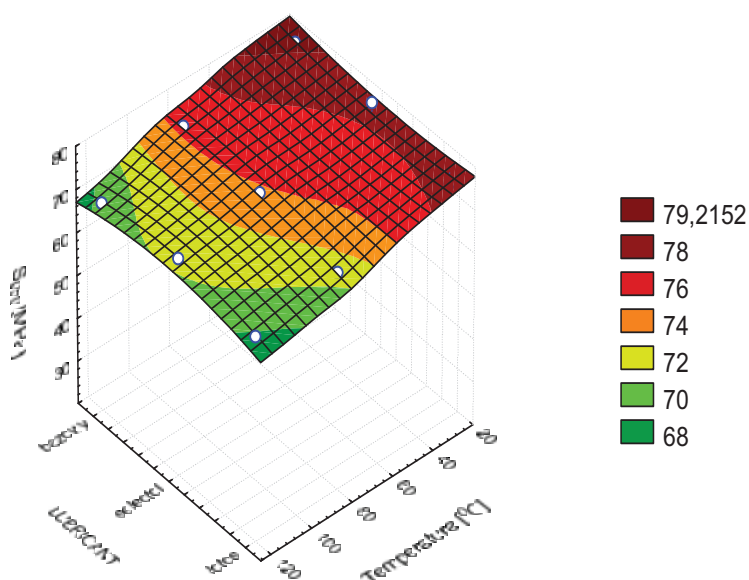

Fig. 5. Fatigue limit stress amplitude vs. temperature and kind of oil for stress ratio $\kappa = -1$

The forms of changes for critical stress amplitudes are similar. For each kind of oil the substantial and variable change of critical stress is visible - the higher the temperature, the higher is the drop in critical stress value. It seems to be clearly also the effect of interaction of two components: the temperature and the kind of oil. This interaction can be explained as reaction to the effects of lubricant additives which are usually stronger for higher temperature. The weakest is the influence of the basic oil which almost not contains active additives.

To prove real significance of these effects statistic analysis was applied using computer simulation (Monte Carlo method). The problem is reduced to the comparison of medians of 27 populations of normal distribution having estimated variations or standard deviations specified in Table 1 (estimated experimental data of s). Each population is described by proper combination of research factors levels: OIL - κ STRESS RATIO – TEMPERATURE. In order to perform ANOVA (analysis of variance) calculation there were generated 27 six-element sets of random numbers by means of generating programme in software package STATISTICA 7. The sets of

random numbers referred to compared populations. For such created sets of results a standard ANOVA procedure of the $3 \times 3 \times 3$ cross-classification has been performed. To compare the effects of factors the Duncan's, Newman-Keul's and Tukey's tests were employed. Such operations were six times repeated. The example of ANOVA calculation results for one of the computer created random number sets is shown in Table 2.

Tab. 2. Results of ANOVA calculations

Effects	Sum of square	Degree of freedom	Mean square	F test	Probability p
κ	21790,0	2	10895,0	4249,6	0,000001
T	5734,4	2	2867,2	1118,4	0,000001
Oil	720,3	2	360,1	140,5	0,000002
T- κ	688,1	4	172,0	67,1	0,000003
T-Oil	83,9	4	21,0	8,2	0,000006
κ -Oil	518,2	4	129,5	50,5	0,000003
T- κ -Oil	183,4	8	22,9	8,9	0,000002
Error	346,1	135	2,6		

The results of statistical analysis were always the same for all repetitions. Main parameters effects were analysed as well as their interactions. All of interactions appeared to be statistically substantial (see bold letters in Tab. 2). Significance level, that is corresponding to comparative analysis result, obtained for different sets of tests was usually much smaller than $\alpha = 0,01$. It means that the results, although determined by computer simulations, are credible.

It can be said that the biggest influence on the critical stress amplitude is demonstrated by stress ratio value κ (Fig. 6). The difference in critical stress amplitude values, in case of stress ratios $K=(+1)$, (0) and (-1) can be seen as a demonstration of strength asymmetry for bearing material loaded with compression and tension.

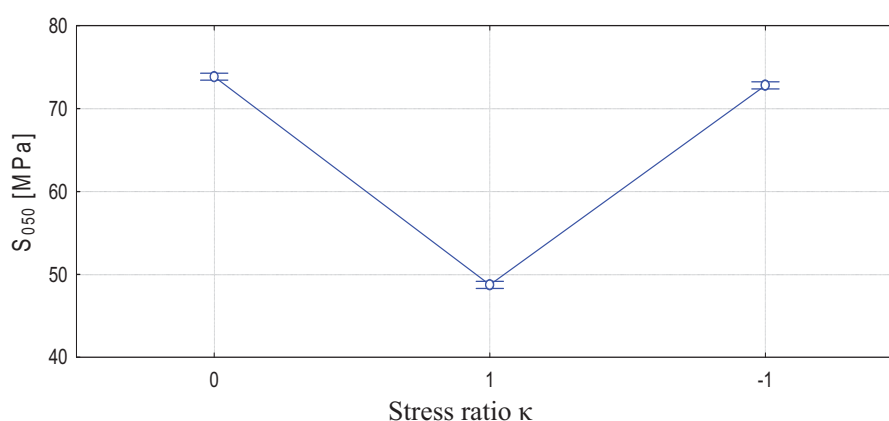
Fig. 6. Main effect of STRESS RATIO κ

In the Fig. 7a the function of $S_{0,50}$ parameter versus temperature is shown, as averaging values for all kind of lubricants and mechanical loadings. The increase of the temperature, from 25°C to 120°C is causing the reduction of fatigue parameter $S_{0,50}$ of about 20%.

Unexpectedly, the effect of kind of lubricant in which the sample of bearing material was immersed, appeared to be quite high. In Fig. 7b the influence of the kind of lubricant, used in the

test, on critical stress value was shown, as averaging values for mechanical and heat loadings. The reduction of the fatigue critical stress value due to some of lubricants can be noticed (up to 7%). The effects of the kind of lubricant is also visible in relation with other test factors (such as R - Oil, Temp.- Oil and R -Oil - Temperature) – Tab.2.

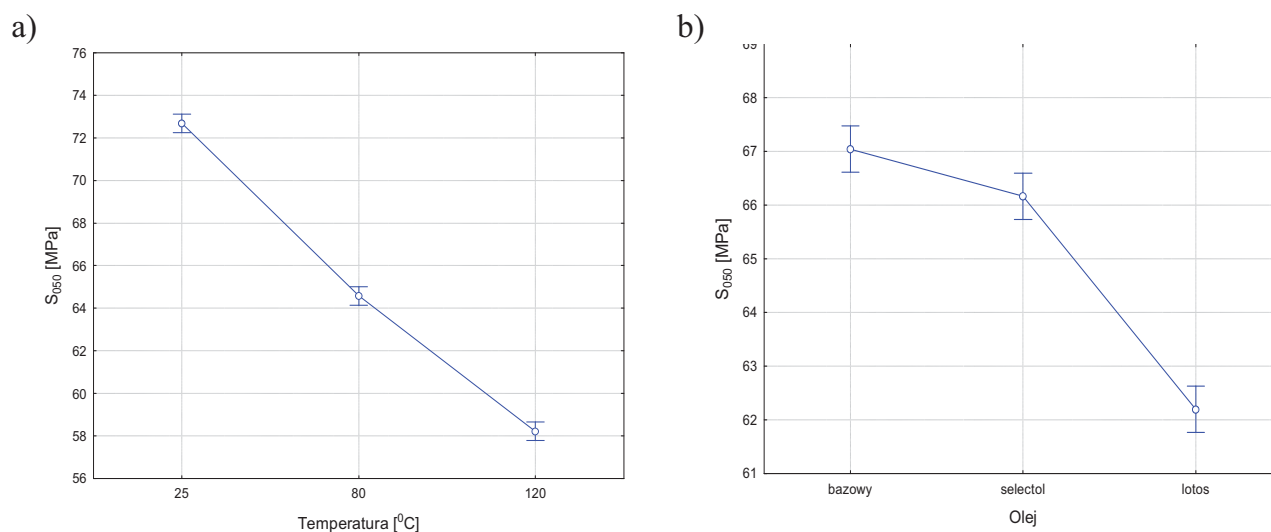

Fig. 7. Main effects of TEMPERATURE and OIL

5. Conclusions

On the basis of fatigue tests for half-shell bearings (bearing layer material AlSn11,3Cu1 on steel backing) obtained on SKMR-2 tester it can be stated:

- Fatigue strength of the bearing material is affected, to the highest degree, by the mechanical stress value and stress ratio ($\kappa = \sigma_m / \sigma_a$) – resistance to the fatigue cracks is being reduced for higher tensional stress,
- Increase in temperature is resulting in decreasing of the fatigue strength rating values,
- Fatigue strength of the slide layer made of AlSn11,3Cu1 is considerably dependent on the type of the used lubricant. It can be explained by the possible effects of the oil additives modifying actions,
- Interactions of the type of the lubricants, their temperatures, loading stress ratio have been noticed.

This work has been financed from budget sources on science in 2005-2006 years as a research project (grant) No 4 T07B 029 28.

References

- [1] ISO 7905/1-4; 1995: Plain bearings – Bearing fatigue-Part I: Plain bearings is test rig and in applications under conditions of hydrodynamic lubrication.
- [2] Sikora, J., Kłopotcki, J., Majewski, W., *Test rig for metallic plain strips of bearing material fatigue investigations - design and evaluation of properties*, Journal of KONES'98, Vol.5, s. 274-279, 1998.
- [3] Sikora, J., *Studia nad metodyką badania wytrzymałości zmęczeniowej łożysk ślizgowych poprzecznych*, Zesz. Nauk. Polit. Gdańskiej, nr 534, Mechanika nr 74, 1996.
- [4] Kurzych, K., *Badania wytrzymałości zmęczeniowej łożyskowych warstw ślizgowych za pomocą specjalistycznego testera*, Praca doktorska, Politechnika Gdańska, 2007.