

## DESCRIPTIVE GEOMETRY TASKS WITH COMPUTER AIDED DESIGN FOR GEODESY AND CARTOGRAPHY

**Bożena KOTARSKA-LEWANDOWSKA**

Gdansk University of Technology, Department of Structural Mechanics and Bridge Structures  
11/12 Narutowicza st., 80-233 Gdańsk, Poland  
email: bokot@pg.gda.pl

**Abstract:** At the courses of studies, where the modules of Engineering Graphics are introduced and the scope of Descriptive Geometry is limited, there is a specific need for a thorough analysis of educational needs for a given specialty. It imposes on the lecturer the duty to constantly search such teaching methods that can easily adapt to the changing world, have the training and practical aspect and can interest students in addition. The example of such attitude is the short program of descriptive geometry course for Geodesy and Cartography prepared with AutoCAD.

**Keywords:** engineering education, descriptive geometry, central projection, perspectives

### 1 Introduction

Applying Computer Aided Design (CAD) is gradually changing the practice of teaching Descriptive Geometry (DG) at the technical universities, initially by developing individual drawing tasks and illustrations of academic lectures, up to creating complete educational platforms. Knowledge resources constructed in this way may support traditional or distance teaching and encourage the development of modern learning environment. In the case of DG it is particularly essential due to the detailed and laborious graphic record of the content of education and the need to condense the program due to a limited number of teaching hours. At the faculty of Geodesy and Cartography DG does not exist as an independent subject, but it is combined with Technical Drawing and CAD which constitute Engineering Graphics and the Elements of Descriptive Geometry. DG belongs to the subjects whose course-content is directly connected with professional subjects such as Topography or Photogrammetry. The course is arranged in such a way that the modules of DG, technical drawing and CAD follow each other, so in practice all geometrical drawing tasks must be performed manually in a traditional way.

### 2 Perspective projection in the course-content

The course consists of teaching representation of 3D objects on a plane with the use of Monge projection, topographic projection, especially road mapping and central projection – perspective [Table 1]. During the construction of the course content much attention was paid to arrive at the optimum proportion between the part of the program referring to the foundations for creating and understanding 2D drawings of 3D objects together with developing spatial visualization abilities and the part referring to the graphic methods of solving practical engineering problems. My own teaching experience shows that graphic methods used for simplified real-life engineering tasks may considerably stimulate students' interest in a given subject.

Table 1

Lp.	Type of Projection	Lectures	Exercises and Project
1	Monge Projection	4	4
2	Topographic Projection	5	6
3	Central Projection	5	6

The principles of central projection constitute the theoretical base for the main professional subjects taught at the Faculty of Geodesy and Cartography that are connected with operation of measuring equipment. Thus teaching perspective should take into consideration not only construction of a perspective view but also reconstruction of an object from a given perspective image. Additionally, the use of CAD in engineering practice makes it necessary to take into account the properties of the tools that this software offers with regard to the curriculum of appropriate subjects in the process of studies. Graphic software that is currently used for modeling of engineering 3D visualization provides a perspective projection, hence the need to acquaint students with the basis of this type of projection. All in all, issues of teaching perspective require careful analysis in terms of the way of teaching.

The analyses of the validity of the course-content were also conducted with regard to selected professional textbooks [1] [2] to specify the range of essential geometrical constructions. Judging from the content of textbooks students proceeding to study photogrammetry should: distinguish types of perspectives, understand meanings of elements of a frame of reference for two-point perspectives, be able to construct the polyhedron with the aid of rotated ground plane and true height measured on the image plane, understand how to rebuild perspective by the indirect method that is construction of a perspective by multiview projection of piercing points of the visual rays and the picture plane. In the drawings there are no measuring points nor methods of measurement which would use the reduced value.

While creating my own course-content it was assumed that geometric construction of perspective should be limited to the basic constructions, but to such extent that students have the opportunity to use the knowledge in a practical way and willingly render visually attractive drawings of simplified architectural structures. Therefore for both aims of construction and reconstruction of perspective, the issues of distance points and measuring points of true length are incorporated in the program of the course.

A good example referring to the graphic methods of solving practical engineering problems is simplified measurement of the ground floor and elevations of a building on the basis of a given photograph, where the theme task is created through usage of the opportunities offered by pasting the photo images into AutoCAD. The carefully prepared photograph represents a two-point perspective of the object. Once the central ray has been established, the vanishing and measuring points of the main directions of the building need to be determined.

In the program there are 3 drawing exercises and 1 project in which the following constructions are to determine:

1. one-point perspectives (Fig.1): a frame of reference: horizon, ground line, center of vision, vanishing and distance points of lines parallel and perpendicular to the picture plane, true height
2. two-point perspective (Fig.2): a frame of reference: horizon, ground line, center of vision, vanishing and measuring points of principal edges of the object, true height

3. two-point perspective (Fig.3): proportions of the sizes of the rotated ground plans depending on the assumed ground line, position of ground line according to the given scale of the rotated ground plan

4. two-point perspective (Fig.4): reconstruction of the perspective from the photograph, a frame of reference, the rotated ground plan, true height and visible elevations in a given scale.

Zad 1. Wykreśl perspektywę czołową obiektu na podstawie danych rzutów prostokątnych. Skala rzutów prostokątnych 1:2.  
Wysokość oka  $h = 4$  cm  
Głębokość tła oka  $d = 9$  cm

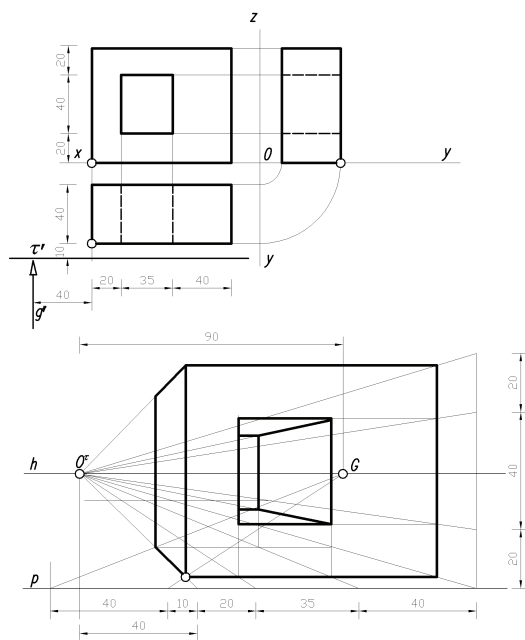

Zad 2. Wykreśl perspektywę czołową obiektu na podstawie danych rzutów prostokątnych. Skala rzutów prostokątnych 1:2.  
Wysokość oka  $h = 3,5$  cm  
Głębokość tła oka  $d = 8$  cm

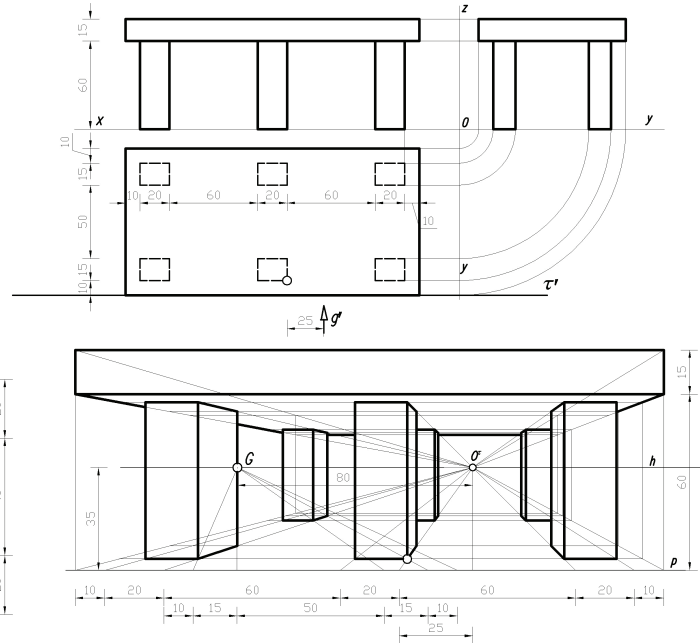
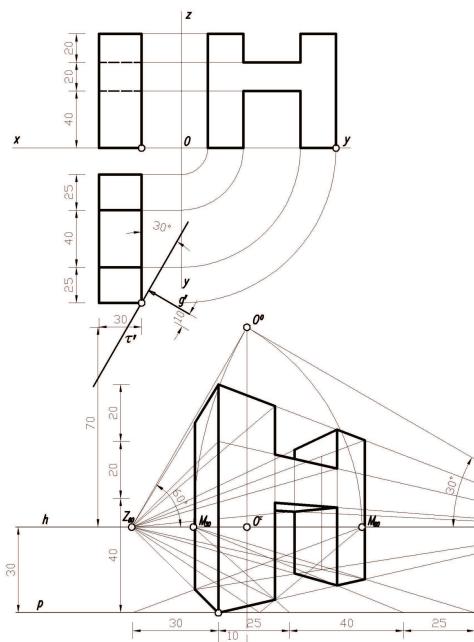

Figure 1: Drawing Task 1, One-point Perspectives (A3)

Zad 1. Wykreśl perspektywę pionową obiektu na podstawie rzutów prostokątnych. Skala rzutów prostokątnych 1:2.  
Wysokość  $h = 3$  cm  
Głębokość tła  $d = 7$  cm



Zad 2. Wykreśl perspektywę obiektu na podstawie rzutów prostokątnych. Skala rzutów prostokątnych 1:2.  
Wysokość  $h = 4$  cm  
Głębokość tła  $d = 7$  cm

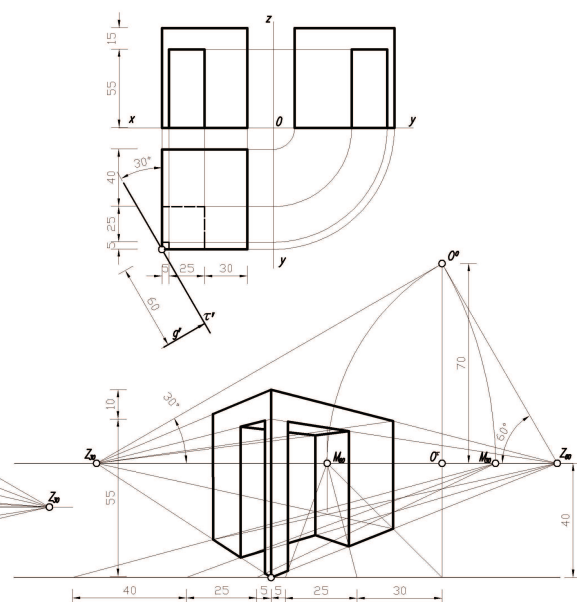

Figure 2: Drawing Task 2, Two-point Perspectives (A3)

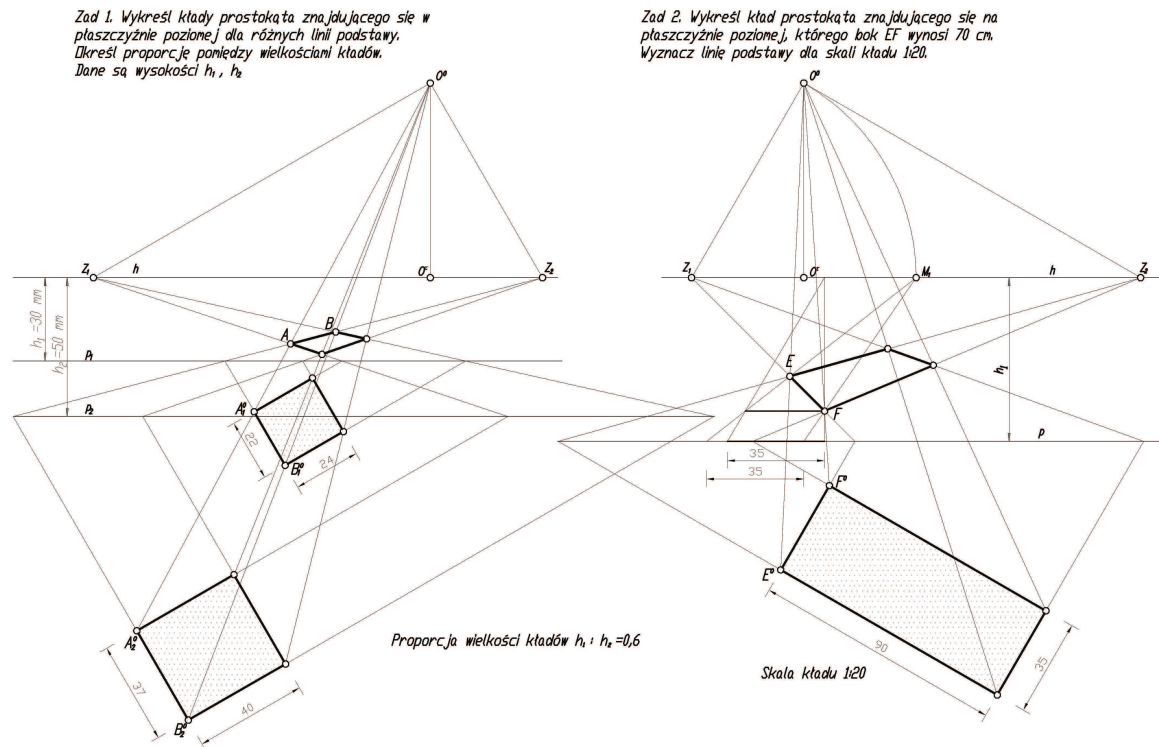

Figure 3: Drawing Task 3, Two-point perspective. The scale of the Ground Plan (A3)

### 3 Reconstruction of the perspective on the basis of the photograph

The task is to be performed by students after just 5 hours of lectures on perspective, so the photographed objects should not be very complex. In the presented task, familiar to everyone electric stations were chosen - structures with simple elevations and an uncomplicated roof. Referential true length and additionally referential height were marked on the structure by fixing the triangle 40 x 40 cm, which provided a fairly good accuracy of measurement.

The photograph should be carefully prepared and represent a two-point perspective of the structure. In order to achieve such a result a leveling tripod can be used. The quality and accuracy of the image may also depend on the focal length, clarity of outlines, the good depth of focus, the curve of the surface of a picture and many other elements, but in the task the influence of these factors is ignored.

Thus in order to achieve the aims of the task it is important to pay attention on the precision of:

- the vertical image of the object
  - location of the referential triangle on the object
  - orthogonal walls of the photographed structure.
- Establishing the main parameters of the picture includes:
- establishing a frame of reference
  - establishing the ground line according to the given scale and ground plan
  - appointing the true height and elevations.

The project integrates the acquired knowledge, as it requires reversal of the order of the operations already performed. Moreover, it demands constant self-control and self-discipline from students during the drawing process.

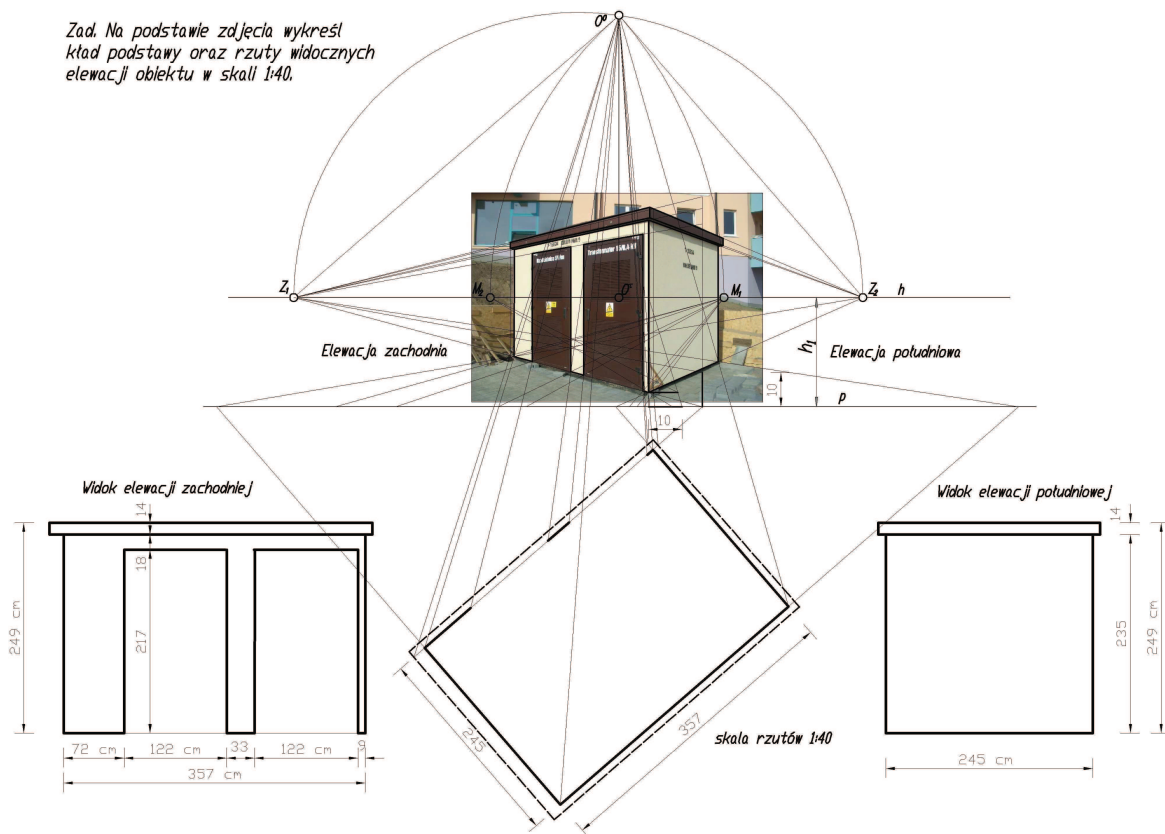

Figure 4: Drawing Task 4, Reconstruction of a two-point perspective of Architectural Structure (A3)

#### 4 Conclusions

The principles of central projection constitute the theoretical base for the main professional subjects taught at the Faculty of Geodesy and Cartography, therefore the selection of both the teaching content and adequate drawing tasks in the descriptive geometry course is particularly important. In the article a thematic scope of perspective and methods of implementing the program with the aid of AutoCAD are presented on the examples of drawing tasks. One of the didactic benefits stemming from using AutoCAD to prepare the topics is the possibility of considerable individuation of topics. The task on photo reconstruction combines the advantages of the project method and the practical benefits resulting from the acquaintance of even just a little scope of the perspective and in this regard can positively affect students' perception of usefulness of graphic methods and their connections with the operation of measuring instruments.

#### References

- [1] Kurczyński Z., Preuss R.: *Podstawy fotogrametrii*, Oficyna Wydawnicza Politechniki Warszawskiej, Warszawa 2000.
- [2] Maciaszek J., Gawalkiewicz R.: *Podstawy grafiki inżynierskiej dla studentów geodezji i kartografii*, AGH Uczelniane Wydawnictwo Naukowo-Dydaktyczne, 2007.

## **GEOMETRIA WYKREŚLNA Z WYKORZYSTANIEM KOMPUTEROWEGO WSPOMAGANIA NA KIERUNKU GEODEZJA I KARTOGRAFIA**

Zasady rzutowania topograficznego i środkowego stanowią teoretyczną podstawę dla kluczowych przedmiotów zawodowych na kierunku Geodezja i Kartografia, dlatego dobór zarówno treści nauczania jak i konkretnych zadań ćwiczeniowo-projektowych w ramach geometrii wykreślnej jest szczególnie istotny. W artykule na przykładzie tematów zadań rysunkowych omówiono zakres tematyczny z perspektywy dla danego kierunku studiów oraz sposoby jego realizacji przy użyciu programu AutoCAD. Dydaktyczną zaletą zastosowania programu AutoCAD do przygotowania ćwiczeń jest możliwość znacznej indywidualizacji tematów. Zadanie na mierzenie obiektu na podstawie zdjęcia łączy zalety metody projektu oraz praktyczne korzyści wynikające ze znajomości nawet niewielkiego zakresu perspektywy i w tym względzie może pozytywnie wpłynąć na postrzeganie przez studentów użyteczności metod graficznych oraz ich związków z działaniem przyrządów geodezyjnych.

