

## AUTOMATED SYSTEM FOR FLUCTUATION ENHANCED GAS SENSING

Maciej TRAWKA, Janusz SMULKO, Lech HASSE

Gdansk University of Technology, Faculty of Electronics, Telecommunications and Informatics  
Department of Metrology and Optoelectronics, G. Narutowicza Str. 11/12, 80-233 Gdansk, Poland  
tel: 58 347 18 84 fax: 58 348 63 73 e-mail: maciejtr@gmail.com

**Abstract:** Resistance gas sensors exhibit random phenomena (resistance noise) which can be utilized to improve gas sensitivity and selectivity. That new emerging technique has to be investigated to recognize optimal parameters for gas detection. It means that a measurement system has to have ability of numerous parameters adjustment (e.g., sampling frequency, heater voltage, polarization current, voltage noise amplification). That fact induced design of a new setup which limits a number of external power sources and reduces time of gas sensors characterization. The newly prepared system comprises two digitally controlled voltage and current sources, and a control unit to select polarization current of the investigated gas sensor. The system is controlled by the dedicated PC software used for data acquisition and communication. The system allows characterizing of prototype gas sensors having a very high resistance, up to tens of  $M\Omega$ . Additionally, the measured sensors can be irradiated by the UV diode to induce photocatalytic effect influencing their gas sensing properties. All these operation have been automated. An every action is automatically logged and state of the system is visualized using windows PC environment. Output files are batch-processed by means of commercial software, such as MATLAB®. Additionally, some exemplary results of recent experimental data for selected gas sensors, such as their noise spectra at various sensors temperatures has been presented.

**Keywords:** gas sensors, fluctuation-enhanced sensing, automation.

### 1. INTRODUCTION

Resistance gas sensors are used in many everyday situations. The most popular applications of such sensors are breathalyzers, CO/CO<sub>2</sub> alarms, flue gas analyzers integrated with car engines, environmental parameters monitoring systems and many more. Although the technology and properties of gas sensors are known, however the main disadvantages of currently used sensors are their insufficient selectivity and high energy consumption. Typically, a gas sensor can respond to more than one chemical substance and it is often impossible to distinguish, what substance is currently present in the sensor environment. Moreover, the high current consuming is caused by using the heater, which is necessary, because currently used commercial gas sensors have to operate with high temperatures, often above 100 Celsius degrees.

To improve a gas sensor selectivity it is possible to measure the noise signal (fluctuation of sensor DC resistance) on its terminals. The power spectral density of the signal

allows better to distinguish gases in the sensor ambient and to measure chemical compounds using only one sensor [1-4]. Additionally, it can be proposed a significant reduction of sensor energy consuming by means of utilization light waves instead of or in addition to heat. This technique has been implemented for new prototype gas sensors, consisting of, for example, WO<sub>3</sub>, TiO<sub>2</sub> or another layers. An example of such a WO<sub>3</sub> gas sensor is presented in Figure 1.

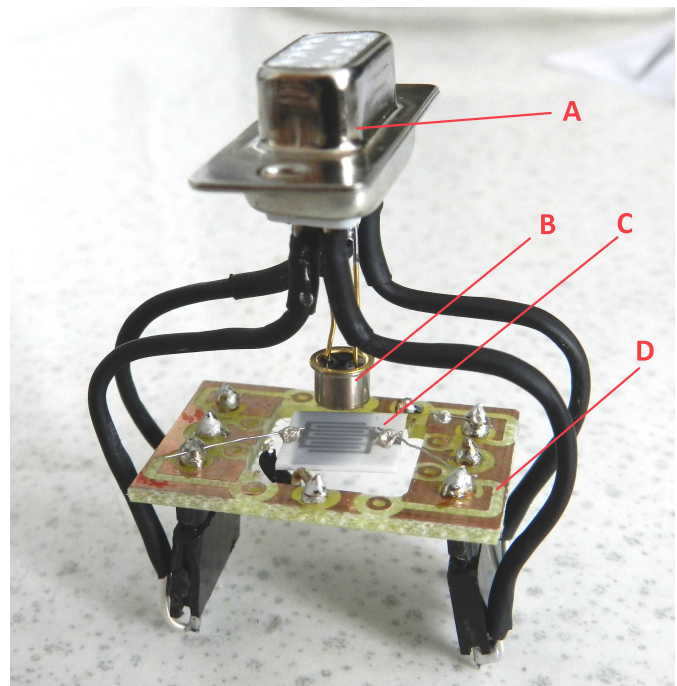

Fig. 1. An example of WO<sub>3</sub> gas sensor. A – DSUB-9 junction (for connection with preamplifier), B – UV LED, C – sensor (top side with heater (bottom side), D – PCB as a mounting plate

Finally, five parameters has been chosen to control or to measure in the system: heater voltage (i.e. sensor temperature), light source (LED) current, sensor resistance, sensor noise and gas composition. If it is necessary to examine the selectivity and efficiency of numerous sensors with respect to these parameters, as many aspects of measuring procedure can be automated as it is required.

## 2. SYSTEM OVERVIEW

In Figure 2 the general structure of the entire system has been shown. As one can see, the system consists of the three main blocks: preamplifier with filters, voltage and current controller and PC computer with National Instruments NIDAQ measurement card (24-bit resolution,  $-5 \div 5$  V, maximum sampling frequency: 100 kHz) and dedicated software.

The measured sensor is polarized with the constant current (approximately 15  $\mu$ A). The sensor voltage, both its DC and AC component, is amplified and the two are separated by using a low pass and a high pass analog filters. Next these signals are directed into two separate channels: the AC, for noise measurement, and the DC – used to measure and compute the sensor resistance. Both channels are connected to the separate ADCs included in the National Instruments measurement DAQ card inside the PC computer. The entire data from this card are processed and acquired using dedicated software. Another function of this software is to control sensor temperature and light intensity. The first is realized by setting a voltage of sensor heater, the second – by controlling a current of light emitting diode, both without a feedback. Besides the dedicated software the Mathworks MATLAB has been used to batch processing the acquired data and to simply present first results of the most measurements.

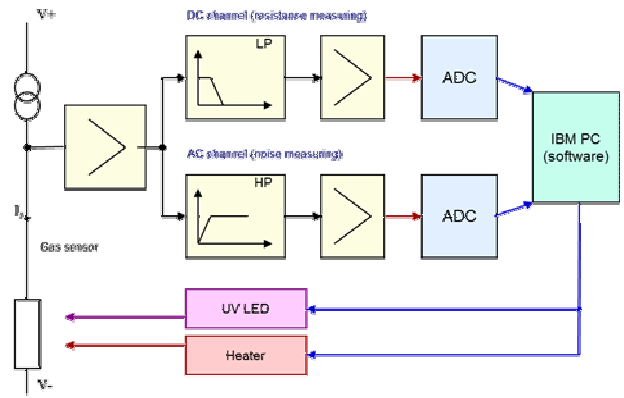

Fig. 2. General block diagram of the measurement system.

## 3. THE HARDWARE PART OF THE SYSTEM

The simplified scheme of the measurement controller is shown in Figure 3. The main part of the unit is Atmega32 RISC microcontroller. The entire digital subsystem is designed to realize a serial communication with PC via RS232 emulated by USB, to drive two DACs used to control a heater voltage and a LED current, and to control an optional thermometer (thermistor or any other semiconductor thermometer). The parallel general purpose digital interface is also included, which can be used to control any optional subsystems.

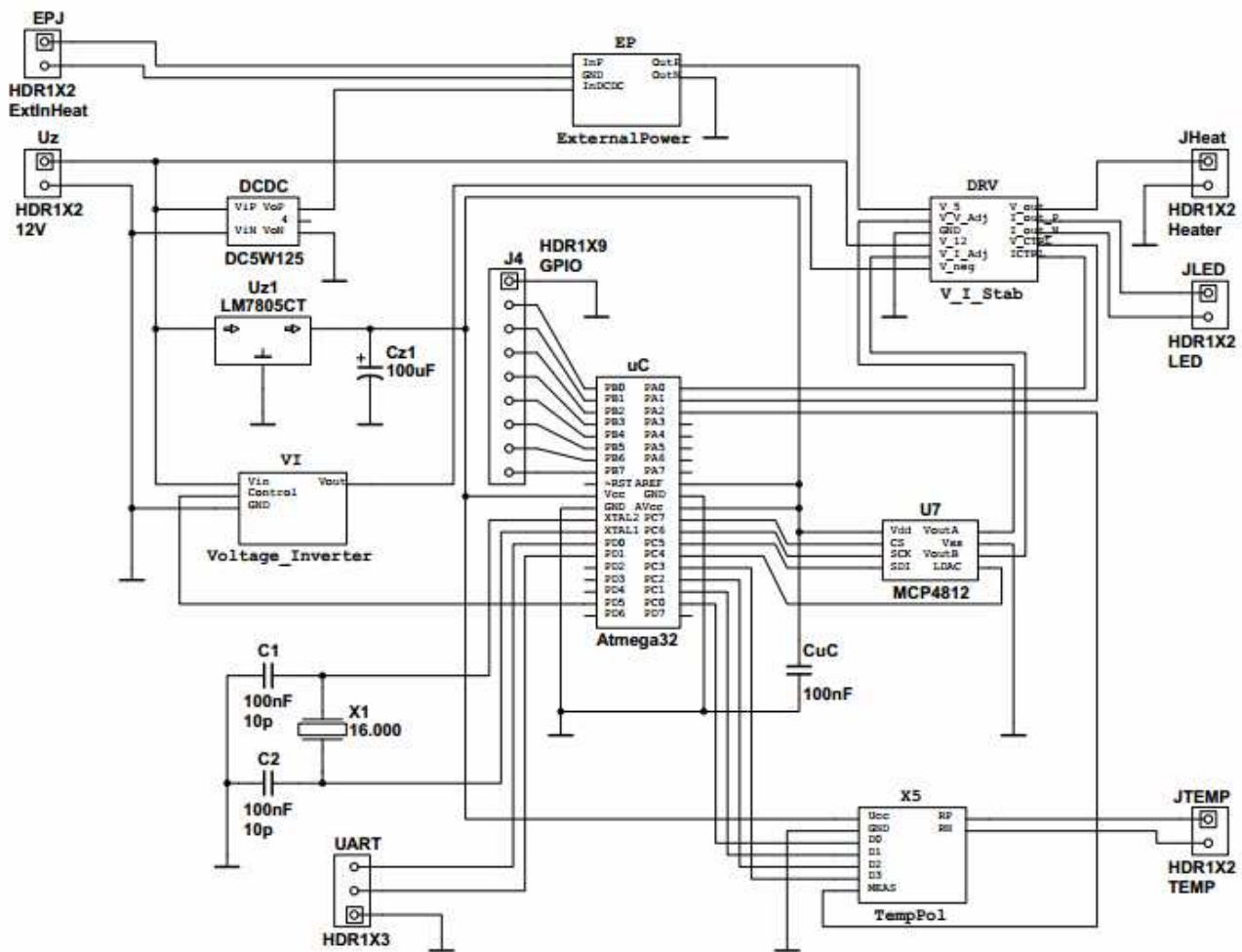

Fig. 3. Simplified scheme of the controller sub-system

The program implemented in the microcontroller provides two types of communication:

- text mode, which is designed for using a terminal or any terminal emulator,
- binary mode, used combined with the dedicated PC software; this mode is more powerful in comparison with the text mode.

The hardware of the measurement system uses feedback loops to control behavior of internal sub-circuits and DACs. The self-test procedure can be called by using dedicated software and the results of the procedure should be analyzed always after startup. The Built-In Self Test (BIST) gives the answer to questions about voltage and current required to power the heater, proper operation of the LED, polarization of the optional thermometer and many others.

By default, the hardware provides control of heaters which require maximum 5V / 0.5A. However, the external-power input is included, to provide the extra-power for heater (6V / 1A max). Switching between power sources (internal / external) for heater is realized automatically, by using a simple transistor circuit with electromagnetic relay: if the external-voltage is between 7 and 10 V, the sub-circuit allows to use the extra-powered heaters. Otherwise the external power is switched off to protect the heater-voltage regulator. If the dedicated software and binary mode of communication is used instead of text mode and terminal, the heater voltage and LED current are regulated more precisely, because the data from feedback ADCs are transmitted to computer "as is", instead of simply computer values using ASCII. The procedure of setting precision value of voltage and current is described in next chapter.

#### 4. THE DEDICATED SOFTWARE

The software is designed using windows in the Visual Basic 6 environment. The exemplary screen-shot is shown in Figure 4. This graphical interface enables to control every aspect of the entire system work. It is important, how the heater voltage and LED current are set. If the function designed to control the voltage (or current) receives the value (number of Volts or Amps), firstly the value is converted using approximated equation and this coarse number is sent to the hardware. Secondly, the microcontroller requests of sending a value from the feedback ADC. Next, the value received from the microcontroller is compared with the desired value and the computed correction is sent to the microcontroller. This algorithm guarantees much better precision than simple setting using terminal and ASCII, without feedback and eliminates error in the estimated equation which converts the desired value into the number for the DAC.

The second task of the dedicated software is to control and communicate with National Instruments PCI DAQ card installed inside the PC. This card is used to measure the sensor resistance and to acquire noise samples.

The another important function of the software is automated controlling of the measurement process. The typical tasks of the software:

1. Setting the heater voltage and LED current using given values (From, To, Step).
2. Waiting for stabilization of the measured sensor; stabilization is detected by checking the sensor resistance or waiting specified number of minutes.
3. Setting parameters of NI PC card and starting sampling process.

4. Saving acquired samples to file, using given data format (formatted ASCII or binary).
5. Creating and storing additional information, used by MATLAB to batch processing the data.
6. If setting voltage and current values are not greater than given "To-values", going to the point 1.

After the measurement process a set of files has been achieved. The set consist of:

- files including acquired samples in ASCII or binary format,
- files including additional information (measurement settings, results of resistance measurement and many others),
- files including list of sample-files and information-files,
- a file including measurement log.

These all files are loaded by MATLAB using dedicated script. Because all required numbers and information are included in the set of files, the data processing is fully automatic. When the process ends, the script returns a set of matrices:

- TimeData – including measured noise samples,
- PSDData – including computed Power Spectral Density function values of the acquired data,
- Legends – matrices including additional data referred to the TimeData and PSDData matrices.

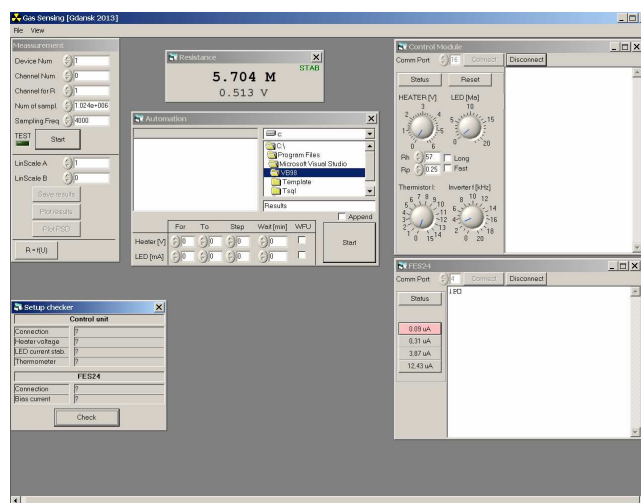

Fig. 4. The screenshot of the dedicated software window

Additionally, some extra prepared scripts allow to present the computed data graphically by means of automatically processed described matrices "as is", without any additional requirements and without the need of additional modifications of these matrices.

#### 5. SAMPLE RESULTS

As a result of measurements, we would often like to see a power spectral density of sensor's noise. The example of that is shown in Figure 5. In this case we have measured noise of the commercial TGS816 gas sensor, placed inside the chamber containing the synthetic air. The example shows the difference between noise levels depending on sensor's heater temperature (150°C and 250°C). The noise levels and shapes of power spectral density curves are associated with gas sensors characteristic phenomena as observed in other gas sensing layers [2]. The shown graph was created directly by the script of MATLAB®.

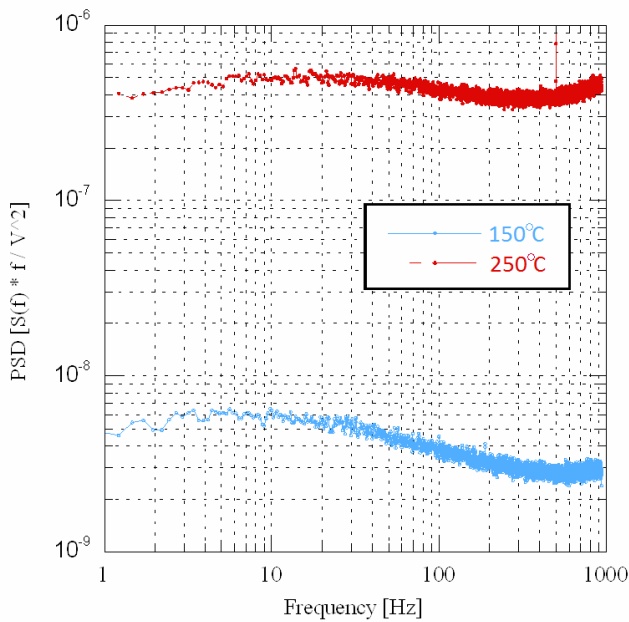

Fig. 5. Example of measurement results – the normalized Power Spectral Density (PSD) of noise generated by commercial TGS816 gas sensor in two different temperatures: 150 and 250°C.

## 6. CONCLUSIONS

A prepared fully automated measurement system is designed to work with a resistive gas sensor, but there are numerous areas of metrology where such an automation can be applied. One of the most important part of a modern measurement and control systems is software. If the measurement system consists of many blocks, units and sub-systems, the main unit should contain high end software to provide required control of the entire system. What is important: if a system should be relatively fast with more than

one process thread, the low-level language to create the control software have to be used. It guarantees a good reliability and the ability to control the execution time of an each procedure used by the system. Good software and a properly designed hardware allow to eliminate human errors and make time of measurement as short as possible.

## ACKNOWLEDGMENT

The research was partially financed by the Polish Ministry of Science and Higher Education (2010/2011), project no. NN511 304338, and by the Czech-Polish project MEB 051003.

## 7. BIBLIOGRAPHY

1. Ayhan B., Kwan C., Zhou J., Kish L.B., Benkstein K.D., Rogers P.H., Semancik S.; Fluctuation enhanced sensing (FES) with a nanostructured, semiconducting metal oxide film for gas detection and classification. *Sensors and Actuators B*, vol. 188, 2013, p. 651 – 660.
2. Ederth J., Smulko J.M., Kish L.B., Heszler P., Granqvist C.G.; Comparison of classical and fluctuation-enhanced gas sensing with  $\text{Pd}_x\text{WO}_3$  nanoparticle films. *Sensors and Actuators B*, vol. 113, 2006, p. 310 –315.
3. Kotarski M., Smulko J., Hazardous gases detection by fluctuation-enhanced gas sensing,” *Fluctuation and Noise Letters*, vol. 9, 2010, pp. 359–371.
4. Trawka M., Smulko J., Hasse L., Granqvist C. G., Ionescu R., Annanouch F. E., Llobert E., Kish L. B., Fluctuation enhanced gas sensing using UV irradiated Au-nanoparticle-decorated  $\text{WO}_3$ -nanowire films, *Proceedings, International Conference on Sensor Technology, Liverpool 2014*.

## ZAUTOMATYZOWANY SYSTEM DO POPRAWY CZUŁOŚCI DETEKCJI GAZÓW Z WYKORZYSTANIEM ZJAWISK FLUKTUACYJNYCH

**Słowa kluczowe:** czujniki gazu, szумы, poprawa czułości, automatyzacja pomiaru.

**Streszczenie:** W rezystancyjnych czujnikach gazu występują zjawiska losowe (np. szумы rezystancji), które mogą być wykorzystane do poprawy czułości i selektywności detekcji gazu. Aplikacja tej stosunkowo nowej techniki wymaga przeprowadzenia badań w celu ustalenia optymalnych parametrów detekcji gazów, co oznacza, że system pomiarowy powinien posiadać możliwość zmiany szeregu parametrów (np. częstotliwości próbkowania, napięcia grzałki, prądu polaryzacji, wzmocnienia napięcia szumów). Implikowało to konieczność zaprojektowania systemu z ograniczoną liczbą zewnętrznych źródeł zasilania i minimalizacji czasu charakteryzowania czujników gazu. Zbudowany system zawiera dwa cyfrowo sterowane źródła prądu i napięcia oraz układ sterujący wyborem prądu polaryzacji badanego czujnika gazu. System jest sterowany z komputera PC za pomocą opracowanego, dedykowanego oprogramowania i umożliwia charakteryzowanie prototypowych czujników gazu o rezystancji aż do dziesiątek  $\text{M}\Omega$ . Czujnik może być ponadto poddany promieniowaniu przez diodę UV w celu wywołania efektu fotokatalizy, co wpływa na czułość detekcji gazu. Wszystkie wymienione czynności zostały zautomatyzowane w jak największym stopniu. Wszystkie wykonywane operacje są automatycznie rejestrowane, a aktualny stan systemu jest wizualizowany w postaci graficznej na monitorze PC. Pliki wyjściowe są przetwarzane wsadowo przy wykorzystaniu komercyjnego software'u takiego jak MATLAB®. Ponadto, przedstawiono przykładowe wyniki pomiarów uzyskane przy wykorzystaniu zaprojektowanego automatycznego stanowiska pomiarowego.