

doi:10.15199/48.2015.11.35

## System of protection against electric shock for circuits with power electronics converters

**Abstract.** Effects of current on people are mainly considered for 50/60 Hz sinusoidal current and smooth direct current. However, modern low voltage circuits are very often equipped with power electronics converters – rectifiers, frequency converters, therefore non-sinusoidal earth currents (touch currents) occur. For non-sinusoidal currents safety criteria should be modified. This paper presents these modified criteria and a computer system of protection against electric shock which can be implemented in circuits with power electronics converters. The system is based on LabVIEW environment. Implementation of the safety system enables the disconnection of supply exclusively when real hazard of the ventricular fibrillation occurs.

**Streszczenie.** Skutki rażenia człowieka są najczęściej analizowane dla prądu sinusoidalnego o częstotliwości 50/60 Hz lub nietętniącego prądu stałego. Jednakże w nowoczesnych instalacjach niskiego napięcia pojawia się coraz więcej przekształtników energoelektronicznych – prostowników, przekształtników częstotliwości, a w takich obwodach mogą płynąć odkształcone prądy ziemnozwarciowe (prądy rażeniowe). Przy prądach odkształconych kryteria bezpieczeństwa powinny być zmodyfikowane. W artykule przedstawiono zmodyfikowane kryteria bezpieczeństwa oraz komputerowy system ochrony przeciwporażeniowej, wykorzystujący środowisko LabVIEW, przeznaczony do obwodów z przekształtnikami. Zastosowanie tego systemu pozwala na wyłączenie zasilania, kiedy pojawia się zagrożenie migotaniem komór serca. (System ochrony przeciwporażeniowej do obwodów z przekształtnikami energoelektronicznymi).

**Keywords:** electrical safety, non-sinusoidal currents, power electronics converters, touch current.

**Słowa kluczowe:** bezpieczeństwo elektryczne, prądy niesinusoidalne, przekształtniki energoelektroniczne, prąd rażeniowy.

### Introduction

Until recently shock hazard has been analyzed only for two typical current waveforms: sinusoidal AC (50/60 Hz) and smooth DC. Figure 1 presents conventional time-current zones of effect of AC current (15÷100 Hz) on a person [1]. For currents up to 0,5 mA there is usually no reaction. Currents between curve *a* and curve *b* have no harmful electrical effects. An area between curve *b* and curve *c*<sub>1</sub> represents reversible disturbances of heart function. Starting from curve *c*<sub>1</sub> ventricular fibrillation may occur and its probability rises with current increase. The probability of about 5% is for currents between *c*<sub>1</sub> and *c*<sub>2</sub>, and about 50% is for currents between *c*<sub>2</sub> and *c*<sub>3</sub>. Beyond curve *c*<sub>3</sub> the probability is higher than 50%. For smooth direct current, similar time-current zones and their description are presented in Fig. 2. Such type of current is less dangerous than AC current (15÷100 Hz). For both types of touch currents (sinusoidal and smooth DC) the most important is the curve *c*<sub>1</sub>. It is identified as the threshold of ventricular fibrillation. In case of AC waveform (15÷100 Hz) and long duration of fault, the threshold of ventricular fibrillation is assumed to be about 30 mA. In case of the smooth DC – about 150 mA.

Nowadays in electrical installations power converts are commonly used and due to their properties various waveforms of earth (touch) currents may occur.

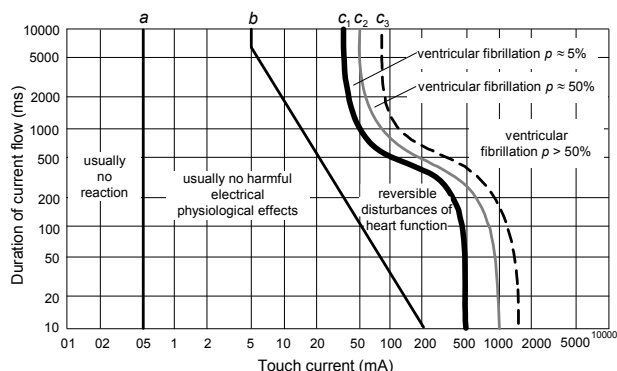

Fig.1. Conventional time-current zones of effect of AC current (15÷100 Hz) on person [1]; *p* – probability of ventricular fibrillation

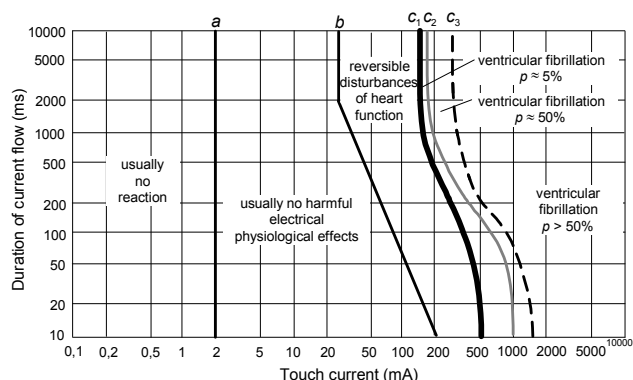

Fig.2. Conventional time-current zones of effect of smooth DC current on a person [1]; *p* – probability of ventricular fibrillation

Figure 3 presents an earth current waveform in case of fault in a circuit with rectifier. The earth current is half wave rectified current – unidirectional but with high pulsation. Similar is the current waveform presented in Fig. 4 – only phase control is added. In case of converters with symmetrical phase control (Fig. 5) earth current is bidirectional. The most interesting, but difficult to analyse, is a circuit with frequency converter for motor speed control (Fig. 6). In such circuit earth current waveform shape depends on the point of fault, actual motor speed and PWM frequency [2-8]. For the above mentioned waveforms the safety criteria presented in Fig. 1 and Fig. 2 cannot be directly applied.

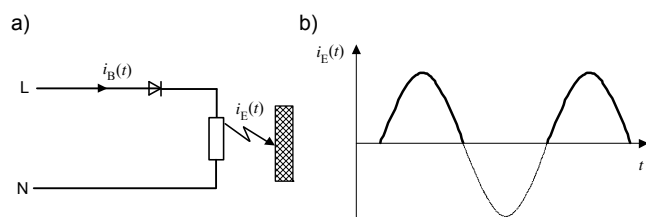

Fig.3. Earth current  $i_E(t)$  in a circuit with half wave rectifier: a) simplified structure of the circuit, b) earth current waveform;  $i_B(t)$  – load current

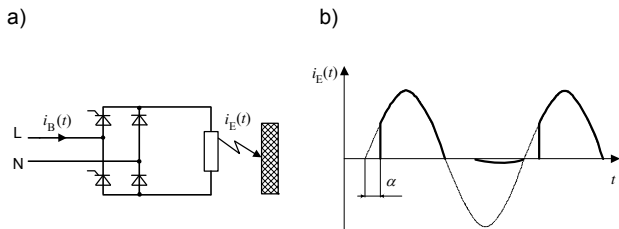

Fig. 4. Earth current  $i_E(t)$  in a circuit with rectifier and phase control: a) simplified structure of the circuit, b) earth current waveform;  $i_B(t)$  – load current

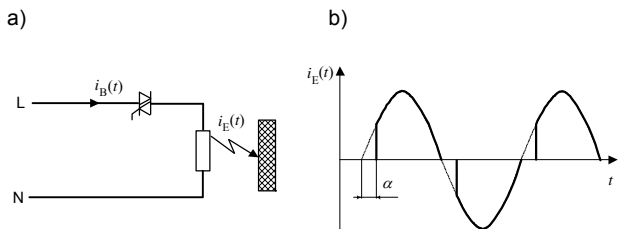

Fig. 5. Earth current  $i_E(t)$  in a circuit with converter for symmetrical phase control: a) simplified structure of the circuit, b) earth current waveform;  $i_B(t)$  – load current

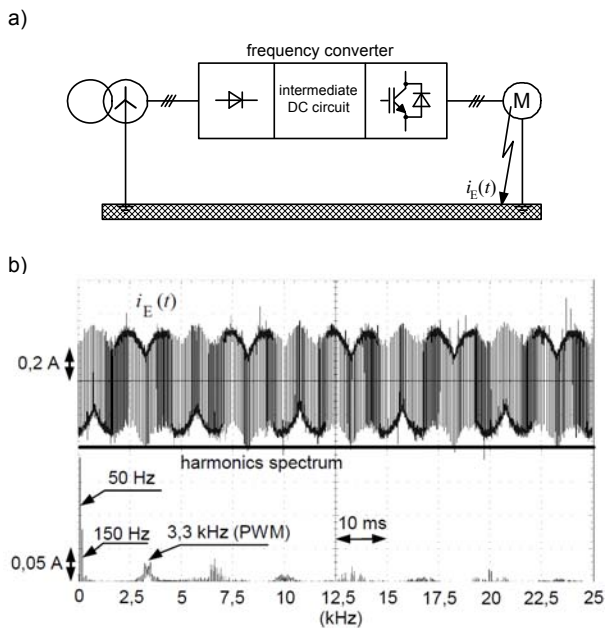

Fig. 6. Earth current  $i_E(t)$  in a circuit with variable speed drive: a) simplified structure of the circuit, b) oscillogram of earth current

The document [9] delivers guidance for modification of the mentioned safety criteria. For selected non-sinusoidal waveforms the methods of equivalent sinusoidal current  $I_{eq}$  calculation (approximate calculation), especially in terms of the threshold of ventricular fibrillation, are described. The next paragraphs present the methods of calculation of equivalent current  $I_{eq}$  – the rms value of a sinusoidal current presenting the same effect as the waveform concerned – and a computer system for automatic evaluation of shock hazard, which enables disconnection of supply in circuits with selected types of non-sinusoidal earth (touch) currents.

### The analysed waveforms of non-sinusoidal currents Half wave rectified current

An analysis of the threshold of ventricular fibrillation in case of half wave current must take into consideration

correlation of shock duration with the period of the cardiac cycle. In the IEC/TS [9] two periods are considered:

- shock duration shorter than 0,75 times the period of the cardiac cycle,
- shock duration longer than 1,5 times the period of the cardiac cycle.

For shock duration shorter than 0,75 times the period of the cardiac cycle the equivalent current can be calculated according to the following expression:

$$(1) \quad I_{eq0,75} = \frac{I_m}{\sqrt{2}}$$

where  $I_m$  – is the peak value of half wave current. Note, that in this type of current the peak value is the same as peak-to-peak value.

For shock duration longer than 1,5 times the period of the cardiac cycle the equivalent current can be calculated as:

$$(2) \quad I_{eq1,5} = \frac{I_m}{2} \cdot \frac{1}{\sqrt{2}}$$

where  $I_m$  – is the peak value of half wave current.

Figure 7 presents the waveforms of the equivalent sinusoidal currents [9].

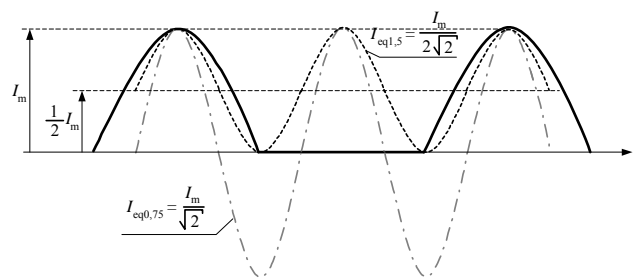

Fig. 7. Equivalent sinusoidal currents for half wave rectified waveform:  $I_{eq0,75}$  – shock duration shorter than 0,75 times the period of the cardiac cycle,  $I_{eq1,5}$  – shock duration longer than 1,5 times the period of the cardiac cycle,  $I_m$  – peak value of half wave current

Example results of calculations of equivalent sinusoidal current for half wave rectified waveform are presented in Table 1. Grey area with the results of calculations indicates values which exceed permissible level (30 mA).

Table 1. Results of calculation of the equivalent sinusoidal current for half wave rectified current

$I_m$ mA	$I_{rms}$ mA	$I_{eq0,75}$ mA	$I_{eq1,5}$ mA
10	5	7,1	3,5
20	10	14,1	7,1
30	15	21,2	10,6
40	20	28,3	14,1
50	25	35,4	17,7
60	30	42,4	21,2
70	35	49,5	24,8
80	40	56,6	28,3
90	45	63,6	31,8
100	50	70,7	35,4

$I_m$  – peak value of half wave current,  
 $I_{rms}$  – rms value of half wave current,  
 $I_{eq0,75}$  – equivalent current for shock duration shorter than 0,75 times the period of the cardiac cycle,  
 $I_{eq1,5}$  – equivalent current for shock duration longer than 1,5 times the period of the cardiac cycle

### Current with symmetrical phase control

In case of waveform with symmetrical phase control, correlation of shock duration with the period of the cardiac cycle should be considered as well [9]. When shock duration shorter than 0,75 times the period of the cardiac cycle is analyzed, the current  $I_{eq}$  is the rms value of a current having the same peak value as the current of the relevant waveform concerned. When shock duration longer than 1,5 times the period of the cardiac cycle is considered,  $I_{eq}$  has the same rms value as the current of the relevant waveform concerned. The waveforms of both the equivalent currents are illustrated in Fig. 8. Calculated values of equivalent current for selected phase angles are presented in Table 2.

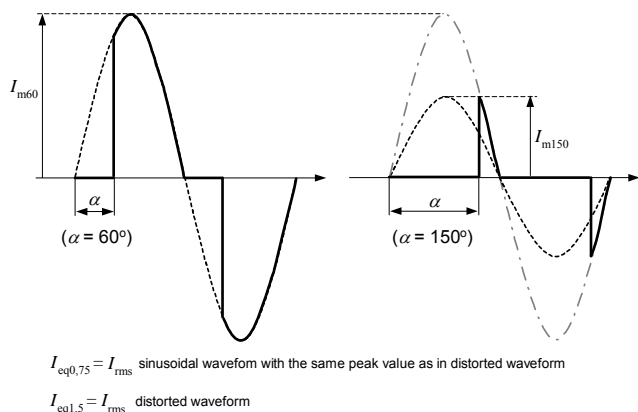

Fig.8. Equivalent sinusoidal currents for waveforms with symmetrical phase control:  $I_{eq0,75}$  – shock duration shorter than 0,75 times the period of the cardiac cycle,  $I_{eq1,5}$  – shock duration longer than 1,5 times the period of the cardiac cycle,  $I_m$  – peak value of the waveform;  $\alpha$  – delay angle

Table 2. Results of calculation of the equivalent sinusoidal current for waveforms with symmetrical phase control

$I_m$ mA	$I_{rms-sin}$ mA	$\alpha$ °	$I_{rms}$ mA	$I_{eq0,75}$ mA	$I_{eq1,5}$ mA
50	35,5	0	35,4	35,4	35,4
		15	35,3	35,3	35,3
		30	34,9	35,4	34,9
		45	33,7	35,4	33,7
		60	31,7	35,4	31,7
		75	28,7	35,4	28,7
		90	24,9	35,4	24,9
		105	20,6	34,1	20,6
		120	15,7	30,5	15,7
		135	10,7	24,8	10,7
		150	6,0	17,4	6,0
		165	2,1	8,8	2,1

$I_m$  – rms value of sinusoidal current flowing for phase angle  $\alpha = 0^\circ$ ,  
 $I_{rms-sin}$  – rms value of sinusoidal current with peak value  $I_m = 50$  mA,  
 $\alpha$  – phase angle delay,  
 $I_{rms}$  – rms value of distorted current,  
 $I_{eq0,75}$  – equivalent current for shock duration shorter than 0,75 times the period of the cardiac cycle,  
 $I_{eq1,5}$  – equivalent current for shock duration longer than 1,5 times the period of the cardiac cycle

When shock duration is between 0,75 and 1,5 times the period of the cardiac cycle, the amplitude parameters change from peak to rms value.

### Current with asymmetrical phase control

For waveform with asymmetrical phase control (Fig. 9), the document [9] indicates the method of calculation of equivalent current only for shock duration shorter than 0,75 times the period of the cardiac cycle. In this case the equivalent current  $I_{eq}$  is, similarly as for symmetrical phase control, the rms value of a current having the same peak value as the current of the relevant waveform concerned.

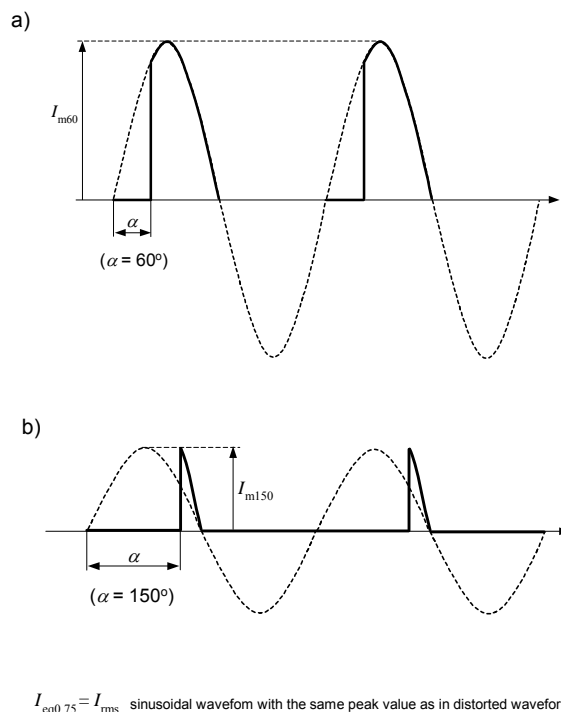

Fig.9. Equivalent sinusoidal currents  $I_{eq}$  for waveforms with asymmetrical phase control:  $I_{eq0,75}$  – shock duration shorter than 0,75 cardiac cycle; a) delay angle  $\alpha = 60^\circ$ , b) delay angle  $\alpha = 150^\circ$

### Alternating current with mixed frequencies

In order to evaluate shock hazard for current with harmonics, the guidance included in the document [9] should be taken into consideration. This document indicates the method of equivalent sinusoidal current  $I_{eq}$  calculation (approximate calculation of rms value in terms of the threshold of ventricular fibrillation), when touch current with harmonics flows [9]:

$$(3) \quad I_{eq} = \sqrt{\sum_{h=1}^n \left( \frac{I_h}{F_{fh}} \right)^2}$$

where:

$I_h$  – value of particular harmonic,  $F_{fh}$  – frequency factor depending on frequency of particular harmonic.

The values of the frequency factor are presented in Fig. 10. The evaluation of equivalent current according to (3) is only a rough approximation because phase angles of high frequency components are not taken into account. Phase angle of a harmonic may significantly influence the peak value of a resultant waveform.

The frequency factor  $F_{fh}$  indicates that for higher frequency the sensitivity of protective devices, especially residual current devices may be relatively lower. It is very important because tripping current of residual current devices may strongly depend on frequency (high frequency components) of residual current.

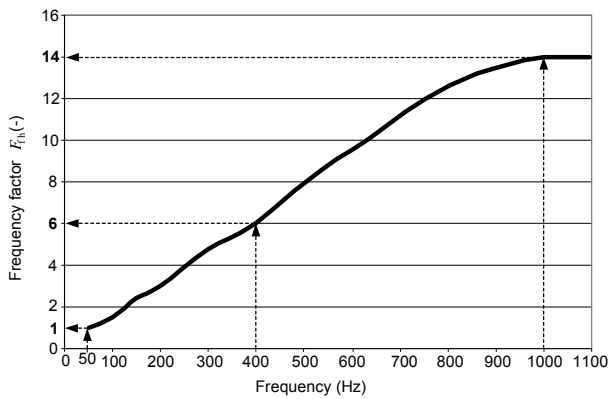

Fig. 10. Variation of the threshold of ventricular fibrillation within the 50 Hz to 1100 Hz frequency range

Figure 11 presents tripping current of selected 30 mA residual current devices:

- AC-type – only for sinusoidal residual current (Fig. 11a),
- A-type – for sinusoidal residual current and pulsating direct current (Fig. 11b).

The laboratory test was performed for the waveforms reflecting earth fault currents in circuits with variable speed drive:

- sin50Hz – pure sinusoidal current,
- 50Hz+PWM – current comprising frequencies: 50 Hz – participation 100%, 150 Hz – participation 25%, 1000 Hz – participation 70%, 900 and 1100 Hz – participation 25%,
- 25Hz+PWM – current comprising frequencies: 25 Hz – participation 60%, 75 Hz – participation 10%, 150 Hz – participation 25%, 1000 Hz – participation 110%,
- 1Hz+PWM – current comprising frequencies: 150 Hz – participation 25%, 1000 Hz – participation 150%.

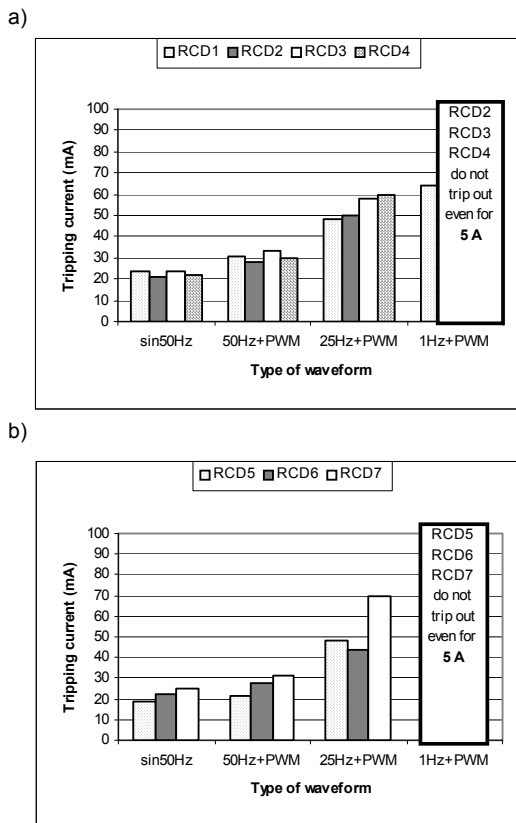

Fig. 11 Real tripping current of 30 mA RCDs: a) AC-type, A-type

The waveform type 50Hz+PWM comprises harmonics which dominate in the earth fault current in case of fault in the output terminals of frequency converters for motor frequency equal to 50 Hz (rated motor speed). The waveform type 25Hz+PWM reflects the earth fault current in case of earth fault in the output terminals of frequency converters for motor frequency equal to 25 Hz (half rated motor speed). The last type of the test waveform (1Hz+PWM) reflects the earth fault current for motor frequency equal to 1 Hz (extremely low motor speed).

One can see that tripping current of all tested RCDs for the waveform 50Hz+PWM is only slightly higher than for pure sinusoidal waveform. For the waveform 25+PWM real tripping current increased over two times in respect to pure sinusoidal waveform. Very dangerous situation occurred for the waveform 1Hz+PWM. The RCD2, RCD3, RCD4, RCD5, RCD6 and RCD7 do not tripped out even for test waveform equal to 5 A rms.

Taking the above into account, it is recommended to elaborate complex safety system which can be dedicated to the circuits with power electronics converters.

### A computer system for protection against electric shock

In order to evaluate shock hazard and ensure protection against electric shock for non-sinusoidal earth currents a computer system with the use of LabVIEW environment [10-14] has been performed. This system enables to calculate equivalent sinusoidal current (from the ventricular fibrillation point of view) for the following waveforms:

- half wave rectified current and full wave rectified current,
- alternating current with symmetrical phase control,
- current with asymmetrical phase control,
- AC current with mixed frequencies.

The type of waveform is selected from the front panel of the computer system (Fig. 12). When the rectified current is considered, an operator of the computer system sets the peak value of the sinusoidal current to be rectified ( $I_m$ ), and the reference value, i.e. permissible value of the sinusoidal current in terms of the ventricular fibrillation ( $I_{ref}$ ) – here 30 mA, typical conventional value [15]. The computer system calculates the rms value of the non-sinusoidal current ( $I_{rms}$ ), the equivalent current for shock duration longer than 1,5 times the period of the cardiac cycle ( $I_{eq 1,5}$ ), and the equivalent current for shock duration shorter than 0,75 times the period of the cardiac cycle ( $I_{eq 0,75}$ ). When current with phase control is analyzed (Fig. 12b), the operator can also set a delay angle for symmetrical or asymmetrical phase control ( $\alpha$ ). Red indicator under the current value informs, that the reference value is exceeded and disconnection of supply should occur. For green indicator there is no risk of the ventricular fibrillation.

The presented computer system enables calculation of the equivalent current for earth current with mixed frequencies as well. Using the front panel of the system (Fig. 13) the operator can define frequency of the fundamental harmonic, higher harmonics, the percentage of every harmonic and its phase angle. After defining the reference value ( $I_{ref}$  – here 30 mA) the system calculates the rms value of the distorted waveform  $I_{rms}$  and the equivalent current  $I_{eq}$  (according to (3)) taking into account frequency factor  $F_{th}$  which is presented in Fig. 10. By red or green indicator the computer system informs whether the reference value is exceeded or not. In the example presented in Fig. 13a the computer system analyses earth current waveform in case of fault in a motor when the motor frequency is equal to 50 Hz (rated motor speed) and PWM frequency is equal to 3 kHz.



### Implementation of the computer system

The computer system for evaluation of shock hazard in circuits with non-sinusoidal earth (touch) currents can be implemented as it is shown in Fig. 14. The system is connected to a residual current sensor for detection of residual current in a circuit with a converter. Such a connection enables to detect both earth current in case of indirect contact and touch current in case of direct contact. Before activating the system, an operator should select a type of power electronics converter from the menu (Fig. 12a). In case of detection of a residual current, the computer system analyses its waveform, calculates equivalent sinusoidal current (within the period no longer than 0,1 s) and decides whether to disconnect or not the supply (via opening a circuit breaker).

The proposed computer system comprises of:

- a residual current sensor with voltage output,
- a data acquisition module (DAQ-M) with analog-digital converter,
- a PC computer with LabVIEW environment.

A residual current sensor should enable to detect currents from DC to at least 20 kHz AC. Voltage signal from a residual current sensor is delivered to the analog input of DAQ-M. Taking into account voltage range of the input signal and sampling frequency, a typical DAQ-M from National Instruments offer may be used. Metrological analysis of this computer system for circuits with variable speed drives is presented in [16].

When earth fault current reaches a predetermined level and disconnection of supply should occur, appropriate signal from DAQ-M for opening the circuit is delivered to a circuit breaker (or contactor) installed in the main circuit of the power electronics converter.

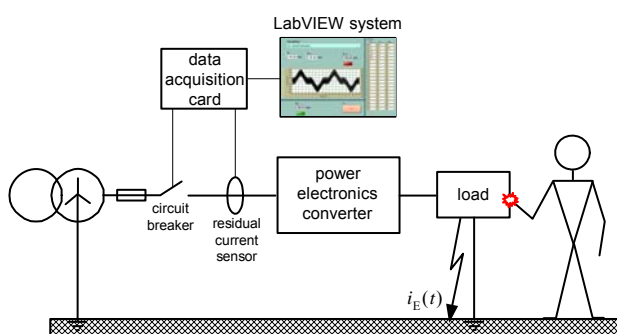

Fig.14. The LabVIEW computer system implemented in a circuit with a power electronics converter

### Conclusion

Electric circuits with power electronics converters characterize non-sinusoidal earth currents. In case of such currents, their effect on a person cannot be directly interpreted on the base of conventional time-current zones of effect of AC current 15÷100 Hz on person included in the document [1]. Non-sinusoidal currents, especially those comprising relatively high-order harmonics, are less dangerous for persons than 50/60 Hz sinusoidal waveform. Taking into account this phenomenon, a computer system for evaluation of shock hazard in circuits with non-sinusoidal earth (touch) currents has been performed. The system enables to adjust a tripping current of a protective circuit

breaker with reference to a type of converter installed in a circuit and expected type of earth (touch) current.

### REFERENCES

- [1] IEC/TS 60479-1:2005 Effects of current on human beings and livestock. Part 1: General aspects
- [2] Beldycki L., Analysis of the effectiveness of protection against electric shock in circuits with frequency converters, MSc thesis (in Polish), Gdansk University of Technology, Gdansk, (2008)
- [3] Czapp S., Guzinski J., The effect of the motor filters on earth fault current waveform in circuits with variable speed drives, Proc. of the 11<sup>th</sup> Conf.-Seminar Int. School on Nonsinusoidal Currents and Compensation ISNCC 2013, Zielona Gora, Poland, 20-21 June, (2013)
- [4] Czapp S., Swisulski D., Computer system for evaluation of shock hazard in circuits with non-sinusoidal earth currents, 12<sup>th</sup> Conf.-Seminar Int. School on Nonsinusoidal Currents and Compensation ISNCC 2015, Lagow, Poland, 15-18 June, (2015)
- [5] Czapp S., The effect of earth fault current harmonics on tripping of residual current devices, *Przegląd Elektrotechniczny*, 85 (2009), nr 1, 196-201
- [6] Czapp S., The impact of higher-order harmonics on tripping of residual current devices, Proc. Int. Power Electronics and Motion Control Conference EPE-PEMC 2008, Poznan, Poland, 1-3 Sept., (2008)
- [7] Skibinski G.L., Wood B.M., Nichols J.J., Barrios L.A., Effect of adjustable-speed drives on the operation of low-voltage ground-fault indicators, *IEEE Trans. on Industry Applications*, vol. 37, no. 5, Sept./Oct. (2001), 1423-1437
- [8] Schoneck J., Nebon Y., LV protection devices and variable speed drives. Cahier technique no. 204, Schneider Electric, 2002
- [9] IEC/TS 60479-2:2007 Effects of current on human beings and livestock. Part 2: Special aspects
- [10] Padure P., Haraguta C.I., Vintea A., Ghita O.M., Evaluation method for harmonic distortion and power losses of photovoltaic systems using LabVIEW software, 49<sup>th</sup> Int. Universities Power Engineering Conference (UPEC), Cluj-Napoca, 2-5 Sept. (2014), 1-6
- [11] Penghui Li, Lijie Zhao, Haijun Bai, Yanhua Zhang, Power quality monitoring of power system based on spectrum analysis, Int. Conference on E-Product E-Service and E-Entertainment (ICEEE), Henan, 7-9 Nov. (2010), 1-4
- [12] Swisulski D., Komputerowa technika pomiarowa. Oprogramowanie wirtualnych przyrządów pomiarowych w LabVIEW. Agenda Wyd. PAK, Warszawa, Poland, (2005)
- [13] Swisulski D., Metody równoczesnej akwizycji w systemach z napięciowymi i częstotliwościowymi torami pomiarowymi, *Przegląd Elektrotechniczny*, 88 (2012), nr 10b, 29-31
- [14] Wei Fu, Yan Zhu, Junli Fu, Puzhong Ouyang, Control and testing system based on LabVIEW for programmable AC power source, 10<sup>th</sup> Int. Conference on Electronic Measurement & Instruments (ICEMI), Chengdu, 16-19 Aug. (2011), 130-133
- [15] HD 60364-4-41:2007 Low-voltage electrical installations – Part 4-41: Protection for safety – Protection against electric shock
- [16] Swisulski D., Czapp S., Metrological analysis of a computerized system of protection against electric shock in circuits with variable speed drives, *Przegląd Elektrotechniczny*, 91 (2015), nr 8, 58-61

**Authors:** dr hab. inż. Stanisław Czapp, Gdansk University of Technology, ul. Narutowicza 11/12, 80-233 Gdańsk, E-mail: [stanislaw.czapp@pg.gda.pl](mailto:stanislaw.czapp@pg.gda.pl)  
 dr hab. inż. Dariusz Świsulski, prof. PG, Gdansk University of Technology, ul. Narutowicza 11/12, 80-233 Gdańsk, E-mail: [dariusz.swisulski@pg.gda.pl](mailto:dariusz.swisulski@pg.gda.pl)