



# **SMALL WOOD WASTE FIRED COMBINED HEAT AND POWER PLANT. POSSIBLE USE OF WOOD BIOMASS FOR THE GENERATION OF ELECTRIC AND HEAT ENERGY AS AN ALTERNATIVE TO FOSSIL FUELS**

**Marek Dzida**

*Gdańsk University of Technology  
Faculty of Ocean Engineering and Ship Technology  
ul. Narutowicza 11/12, 80-950 Gdańsk, Poland  
e-mail: dzida@pg.gda.pl*

## **Abstract**

*This article discusses the possibility of burning wood biomass instead of fossil fuels in boilers. It describes the properties of wood biomass, including the variation of its calorific value depending on the moisture content of wood. The article proposes several variants of a combined heat and power plant (CHP) system burning wood biomass for the generation of electric and heat energy, using the energy contained in exhaust gases for drying wood biomass.*

**Keywords:** *renewable energy sources, wood biomass, power plant systems*

## **1. Introduction**

Waste materials of plant origin pose a considerable challenge in terms of their efficient utilisation. Their use in power generation is often impossible due to their moisture content, physical state or dimensions.

Main sources of biomass include wood waste derived from logging, forest clearance or wood machining. It is estimated that there are 3 million tons of wood waste produced every year in Poland, while only 40% is used for power generation [5].

On the one hand, facilities such as sawmills, large furniture manufacturers and woodworking sector plants generate vast amounts of wood waste and face problems concerning its disposal; on the other hand – their operation requires electric and heat energy. Their boiler rooms often run on fuels other than wood waste.

Wood waste is characterised by a high calorific value and may be successfully used in small thermal power stations or combined heat and power plants. Wood is harvested from felled trees and processed into various products, such as boards, square-sawn timber, balks, etc., resulting in a large amount of waste.

There is 60-64% waste in 100 m<sup>3</sup> of wood derived from forestry. Such waste includes bark, slash, waste in pieces, as well as sawdust and chips. It is assumed that 100 m<sup>3</sup> of harvested wood include 16% bark, 13% slash, 31% waste in pieces and approx. 29% sawdust and chips [1]. The waste may be used to produce briquette or wood for burning in boilers or stoves (only wood pieces), however, a large part of it

is still not utilised.

Wood biomass may also be produced from wood acquired as a result of the restoration of green areas and forests, orchards or urban greenery purges or the recycling of wood-based materials.

A considerable challenge in the combustion of wood or wood waste is the high dependence of the calorific value of this fuel on the wood moisture content.

This article presents an alternative use of wood biomass for generating electric and heat energy in a small power plant. Such a power plant may become an alternative to a conventional fossil fuels fired power plant and may be adapted to burning wood waste from wood processing plants: sawmills, furniture manufacturers, etc. It provides for the possibility of utilising waste from such plants and establishes a source of inexpensive electric and heat energy for manufacturing purposes. Furthermore, as the energy is derived from wood biomass, such a power plant is considered environmentally friendly.

## 2. Calorific value versus moisture content

The calorific value of wood or wood waste depends most of all on the wood moisture content and density.

Wood moisture content is a ratio between the weight of the water in the wood and the weight of the wood itself, expressed as a percentage. Completely dry wood may only be obtained in a laboratory setting as a result of artificial drying at a temperature of approximately 1000°C, while protecting it against absorbing moisture from the surroundings.

Freshly harvested wood has varying moisture content that depends on the type of wood and its age, its growing conditions and the time it was harvested [6]. The moisture content of freshly harvested wood is 50-60%, after a year of seasoning – 25-35%, and after many years of storage — 15-20% [4]. 8-12% moisture content may only be reached with a forced drying process in kilns or enclosed heated spaces.

A property that differentiates wood fuels from fossil fuels is their high content of volatile matter: approximately 75-83% of dry matter evaporates during heating, while the remaining part includes 15-24% non-volatile carbon compounds (combined carbon) and 0.3-4% ash, Table 1.

Tab.1. Composition and calorific values of selected types of dry biomass in acc. [3]

Wood type	chemical analysis [% by weight]			Chemical composition [% by weight]						Calorific value [MJ/kg]	
	SL	W2	a	C	H	O	N	S	Cl	Wu	Wu*)
Fir	82.1	17.46	0.44	51.2	5.98	42.1	0.06	0.03	0.19	20.42	19.115
Pine	75.6	21.37	3.03	51.3	4.69	40.3	0.51	0.02	0.02	20.588	19.565
Oak	86.2	13.5	0.3	50	5.92	43.7	0.03	0.01	0.01	19.478	18.186
Poplar	86.1	12.24	1.66	50.8	5.89	41	0.59	0.02	0.04	18.931	17.646
Willow 1	79.5	18.5	2	48.4	5.87	43.3	0.42	0	0.01	19.1	18.02
Willow 2	80.8	17.6	1.6	48.2	5.84	43.4	0.41	0.05	0	19.6	18.326
Spruce	84	13.9	2.1	48.9	5.78	43	0.2	0	0	19.533	18.246
Birch	78.7	20.98	0.32	48.7	6.4	44.5	0.08	0	0	19.223	17.892
Beech	75.2	24.2	0.6	48.1	6.4	44.8	0.08	0	0	18.833	17.53
Wheat straw	78.9	15.2	5.9	46.4	5.67	40.8	0.69	0.1	0.44	18.252	17.016
Miscautius	82.1	16.4	1.5	48.4	6.3	43.3	0.3	0.1	0.13	19.98	18.205
Miscautius (dried)	75.4	20.55	4.05	47.3	5.79	41.9	0.43	0.06	0.47	19.36	18.097
Urban greenery (contaminated wood)	57.2	15.7	27.1	34.1	3.32	34.5	0.81	0.08	0.09	14	13.28
Urban greenery (wood)	71.7	20	8.3	48.1	5.76	37	0.64	0.1	0.1	18.14	16.883

SL–volatile substances; W2–combined carbon; a–ash; C–carbon; H–hydrogen; O–oxygen; N–nitrogen; S–sulphur; Cl–chlorine  
\*) – calorific value calculated by applying formula (1)

The chemical composition (Tab.1) of different types of wood also depends on the function performed by a particular section of the plant; that is why the stem, root, bark, etc. all have a different composition. Data given in the Table show that on average wood used for energy production contains as follows:

carbon	– C	48-51%
hydrogen	– H	4.7-6.5%
oxygen	– O	40-43%
nitrogen	– N	0.1-0.5%
sulphur	– S	0-0.02%

It may be concluded that many types of wood contain no sulphur or their sulphur content is minimal, such as not exceeding 0.02%, therefore, after burning they do not generate sulphur oxides (SOx) and may be considered environmentally friendly.

The calorific value of wood that can be found in different sources most often refers to dry wood with zero moisture content. Wood of such a calorific value is not used for combustion. The calorific value of wood biomass is also given in Table 1. The calorific value of dry wood depends on the type of wood and amounts to 18-21 MJ/kg. It must be noted that bark, i.e. the outer surface of wood, is characterised by a similar calorific value to wood proper and amounts to 7-21 MJ/kg, while its ash content is approximately 1-3% [1].

The calorific value of dry wood may be determined from the dependence on the percentage composition of wood. There are many formulas describing the calculation of the calorific value of wood. References [3,2] provide the following dependence that enables the calculation of dry wood calorific value:

$$Wu = 0,341 \cdot C + 1,322 \cdot H - 0,12 \cdot (O + N) + 0,0686 \cdot S - 0,0153 \cdot a \quad \left[ \frac{MJ}{kg} \right] \quad (1)$$

while the content of elements in the wood and ash *a* should be given in percentage content in the weight of the wood.

Table 1 also lists the calorific value of wood calculated using dependence (1). The error between the calorific value given in references [3] and the calculated one does not exceed 2-6%.

Water (moisture) content significantly affects the fuel calorific value. References [3] provide a dependence describing the determination of calorific values depending on the moisture content of wood.

$$Wd = (Wu - r_{25^{\circ}C} \cdot \frac{H}{2} \cdot M_{H_2O}) \cdot (1 - w) - r_{25^{\circ}C} \cdot w \quad \left[ \frac{MJ}{kg} \right] \quad (2)$$

where *Wu* [MJ/kg] - calorific value of dry wood,  
*r*<sub>25°C</sub> [MJ/kg] - heat of water evaporation at 25°C,  
*M*<sub>H<sub>2</sub>O</sub> [kg/mol] - water molecular mass,  
*H* - mass fraction of hydrogen in wood,  
*w* - mass fraction of water in wood.

Fig. 1 shows the calorific values of selected types of biomass depending on their water content in the weight of the wood. The calorific value decreases with the water content of wood for all types of fuels shown in the diagram. This dependence is highly linear. The presented analysis shows that the calorific value of harvested wood of approximately 50% moisture content equals 40% of the calorific value of dry wood (a 2.5-fold reduction). The calorific value of wood seasoned for one year (30% moisture content) is

60% of the dry wood value (a 1.6-fold reduction). In the case of wood seasoned for several years (20% moisture content) it drops down to 72% in relation to the calorific value of dry biomass (1.4-fold reduction).

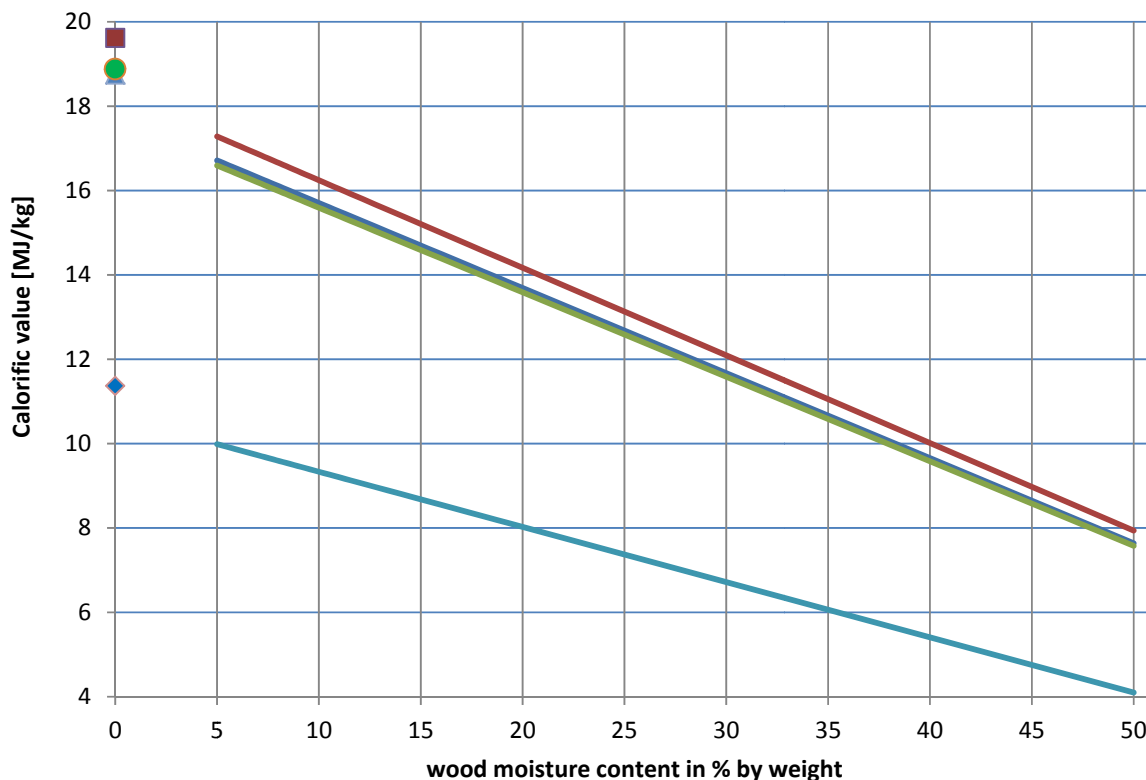

Fig. 1. Calorific value of selected types of wood in relation to moisture content  
point symbols – calorific value of dry wood (0% moisture content)

▲ pine; ■ oak; ● willow; ◆ urban greenery (contaminated)

Forced drying of wood provides for 10-12% moisture content and as a result the calorific value of such a fuel drops down to 83% (1.2-fold reduction) of the calorific value of dry wood, i.e. the fuel of such moisture content provides for the highest possible calorific value of wood biomass in actual conditions. The changes are presented in Fig. 1 and 2. According to the previous description, zero moisture content in wood biomass cannot be maintained, that is why in actual conditions the calorific value should be referenced to wood biomass of 10% moisture content. Fig. 2 shows alternative trajectories of the biomass calorific value with reference to zero moisture content (Curve 1) and 10% moisture content (Curve 2). The trajectory of the curves shows that in actual conditions an increase in moisture content from 10% do 20% results in a decrease in the calorific value by 12.5%, while an increase in moisture content to 30% results in a decrease in the calorific value to 25% and for 50% moisture content it drops down to 60% of the calorific value of wood of 10% moisture content.



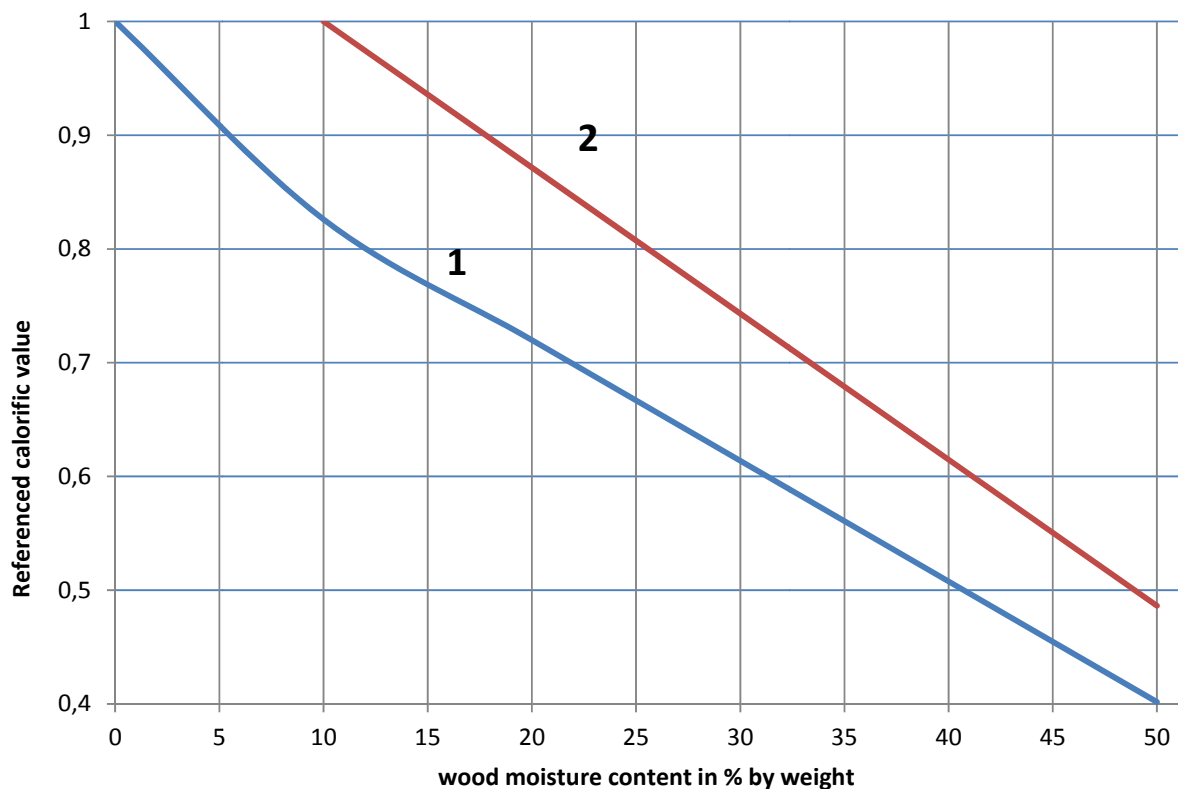

Fig. 2. Referenced calorific value of willow in relation to wood moisture content  
 — (1) - reference to the calorific value of dry wood;  
 — (2) - reference to the calorific value of wood of 10% moisture content

The analysis shows that wood biomass including wood waste and bark is characterised by high calorific values. The calorific value of wood significantly decreases depending on the increased water content of the wood, that is why forced wood drying more than doubles the calorific value of biomass of 10% moisture content in relation to wood of 30% moisture content. This fact is of great importance to wood-fired power plants. Forced drying must be used in order to obtain biomass of 10% moisture content because natural seasoning only provides for 15-25% moisture content. Heat energy and air of the temperature of 100°C are both necessary for forced wood drying. It is assumed that 1000-2000 MJ of heat is necessary for drying 1 m<sup>3</sup> of wood (depending on the starting temperature and the moisture content of the wood), while the time it takes for biomass to reach approximately 10% moisture content is between three and four weeks. The drying times are given for the method of drying wood used in furniture manufacturing or structural lumber, where cracking, bending, warping, etc. should be avoided. The actual wood biomass drying time would probably be shorter, as wood fuel does not require such a strict drying regime.

The use of wood biomass in the power plants discussed in the article also provides for the possibility of using waste heat contained in the exhaust gases from a boiler or a gas turbine for drying wood without increasing the costs of energy supplied to the wood kiln chambers. This leads to lower heat and electric energy costs. A reduction in wood biomass moisture content doubles the calorific value of freshly harvested wood.

### 3. Models of cycles of combined heat and power plants burning fuel derived from waste wood

Several power plant system cycles are suggested for the use of wood biomass as a fuel. It was assumed that wood biomass would be burned in the boiler and that the cycles of a steam turbine or a gas turbine would be used. The power plant would be used for producing electric and heat energy. Heat energy contained in exhaust gases from the boiler would be used for drying wood biomass. Such a solution would make it possible to increase the calorific value of wood biomass, while reducing its moisture content.

#### 3.1. Conventional power plant with a heating steam turbine – variant A

The CHP diagram in Fig. 3 shows a system with a conventional heating steam turbine cycle. Some of the steam is used for heating water in a district heating heat exchanger (DHHE) and the condensate is drained to the deaerator. If the correct temperature of feed water at the deaerator outlet is not reached, steam from an additional (valve controlled) turbine coupling is supplied to the deaerator. Exhaust gases are released from the boiler to a wood drying kiln (WDK). In case of exhaust gas temperature falling below 100°C, a vacuum deaerator is used. The steam turbine drives an electric generator.

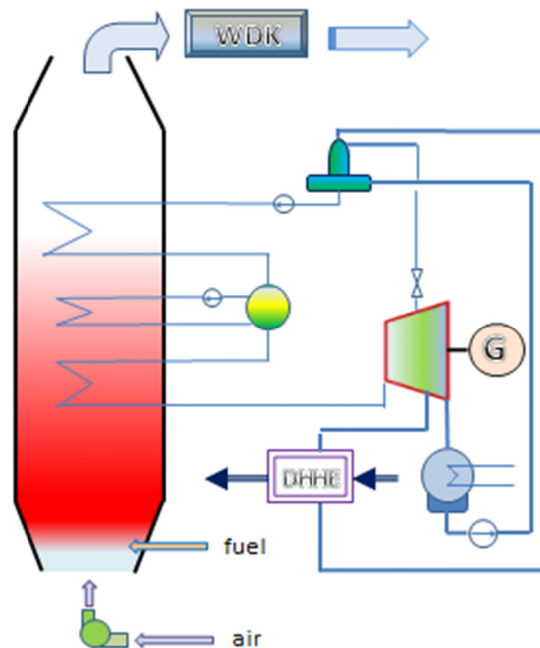

Fig. 3. Diagram of a combined heat and power plant system with a heating steam turbine – variant A

#### 3.2. Power plant with a gas turbine and a boiler fed with air from a fan – variant B

In this solution a gas turbine is used in which air is the working medium. The function of a gas turbine combustion chamber is served by an exhaust gas and air type exchanger in which compressed air from the compressor is heated to a set upper temperature of the cycle. The exchanger is installed in the boiler furnace chamber.

The boiler is fed from a separate air fan. Working air from the gas turbine is not supplied to the boiler; the boiler air and the working medium cycles of the gas turbine cycle are separated.

In this solution the hot working medium from the gas turbine – the air – is directed from the turbine outlet to the DHHE where it heats up heating water. Air temperature at the DHHE outlet is high and may

be directed to the WDK chamber. In this case the air is clean and hot, therefore, the chamber may be used for drying structural lumber, not wood biomass. Two variants of a CHP system with a gas turbine are shown in Fig. 4.

In variant B1, Fig. 4a, an additional steam turbine cycle is used (a combined gas and steam system). Exhaust gas in the boiler, at the outlet of the gas turbine cycle heat exchanger area, releases its heat to the steam turbine cycle. The steam turbine is equipped with a single coupling for the steam heating the deaerator. Electric energy is produced in a generator driven by the gas and steam turbine. The selected generator may be a single unit driven by the steam and gas turbines simultaneously, or each turbine may have a separate generator. Exhaust gases at the boiler outlet feed a wood drying kiln. With direct exhaust gas feeding, the kiln may be used for drying wood waste. In the case of drying structural lumber, warm air should be used (therefore, an additional exhaust gas and air exchanger is required).

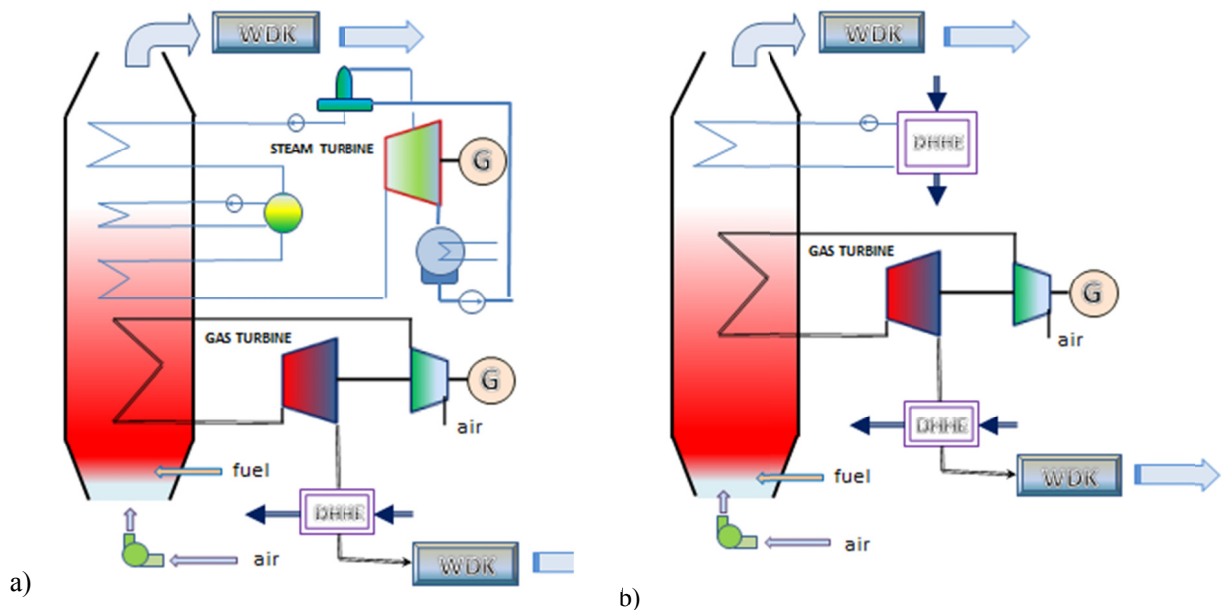

Fig. 4. Diagram of a combined heat and power plant system with a gas turbine and a boiler fed with air from a fan

- a- variant B1 – combined gas and steam system
- b- variant B2 – system with a gas turbine and heat exchangers

In variant B2, Fig. 4b, a DHHE heat exchanger is used instead of a steam turbine cycle in the boiler downstream of the gas turbine cycle exchanger. Electric energy is produced only in an electric generator driven by a gas turbine. A wood drying kiln is used at the boiler outlet in order to dry wood biomass. In this variant, in comparison with variant 4a, the WDK used at the air outlet from the gas turbine is identical; the same amount of heat energy contained in discharge air is exchanged. The power ratings of the gas turbine in both variants are identical. More electric energy, however, is produced in variant 4a, because of the additional power of the steam turbine driving the electric generator. The situation is exactly opposite in the case of heat energy. In both variants – 4a and b – the thermal power of the DHHE exchanger installed at the gas turbine outlet is identical. In variant 4b there is also the additional thermal power produced in the DHHE exchanger in the boiler.



### 3.3. Power plant with a gas turbine and a boiler fed with air from the gas turbine – variant C

Variant C, Fig. 5, includes boiler supply with hot discharge air from the gas turbine cycle. A DHHE heat exchanger is used in the boiler, downstream of the gas turbine cycle heat exchanger. If the amount of air required by the boiler is lower than the air stream in the gas turbine cycle, a valve on the turbine outlet pipeline opens and the hot air may be used in the wood drying kiln. The exhaust gases at the boiler outlet feed the biomass drying kiln.

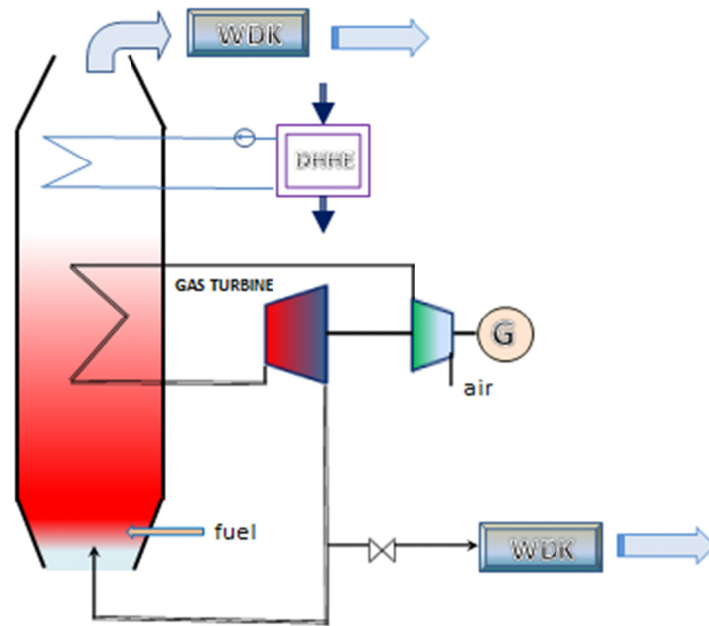

Fig. 5. Diagram of a combined heat and power plant system with a gas turbine and a boiler fed with air from the gas turbine – variant C

## 4. Conclusion

The proposed wood biomass fired combined heat and power plant systems may become an alternative to conventional power plant solutions due to:

- a large amount of wood waste generated in sawmills, the woodworking sector, including furniture manufacturing, and a large amount of waste of a high calorific value from selective tree and green areas harvesting,
- the proposed method for drying wood waste with waste heat from the cycle doubles the fuel calorific value without increasing the costs of heat energy necessary for the forced drying of wood biomass,
- the use of wood biomass in the woodworking sector enables a reduction in the costs of electric and heat energy required by a facility, but surplus electric and heat energy may also be generated,
- wood biomass is an environmentally friendly fuel as it comes from a renewable energy source; it has a “zero” CO<sub>2</sub> emission balance.

Another stage of implementation of the presented wood biomass fired power plant systems includes detailed thermodynamic calculations and a technical analysis of the proposed combined heat and power plant systems.



## References

- [1] *brykietownia.com*. (2015). Downloaded: August 2015 at [www.brykietownia.com](http://www.brykietownia.com).
- [2] Głodek, E. (2010). *Spalanie i współspalanie biomasy*. Opole, Poland: Institute of Ceramics and Building Materials.
- [3] Kalina, J. (2013). *Analiza i optymalizacja układów technologicznych energetyki rozproszonej zintegrowanych z termicznym zgazowaniem biomasy*. Gliwice, Poland: Wydawnictwo Politechniki Śląskiej.
- [4] *komdrew.pl*. (2015). Downloaded: 08 2015 at [www.komdrew.pl](http://www.komdrew.pl)
- [5] Obidziński, S. (2004, 5/60). Ciepło spalania i wartość opałowa kory drzew liściastych i iglastych. *Inżynieria Rolnicza*.
- [6] Rybak, W. (2006). *Spalanie i współspalanie biopaliw*. Wrocław, Poland: Oficyna Wydawnicza Politechniki Wrocławskiej.