

Low-power device simulator for micro-energy measurement methods testing

Abstract. The paper presents low-power device simulator designed for testing of micro-energy measurement methods. Such kind methods can be used for evaluation of power systems based on Energy Harvesting. The device allows to set the current consumption characteristic over the time, thus making possible playing the role of different types of low-power devices e.g. simulating sensor network node.

Streszczenie. W artykule omówiono symulator urządzenia mikromocowego przeznaczony do testowania metod pomiaru mikroenergii wykorzystywanych podczas oceny energetycznej systemów zasilania opartych na pozyskiwaniu energii ze środowiska. Urządzenie pozwala na kształtowanie przebiegu poboru prądu w czasie, co umożliwia odtwarzanie zachowania dowolnego urządzenia mikromocowego np. symulację węzła sieci sensorowej. (Symulator urządzenia mikromocowego do testowania metod pomiaru małych energii).

Keywords: micro-energy measurement, energy harvesting, coulombmeter, low-power devices.

Słowa kluczowe: pomiar mikroenergii, pozyskiwanie energii ze środowiska, kulombometr, urządzenia mikromocowe.

Introduction

The paper concerns the topic of supplying low-power devices as well as energy harvesting methods. In the last years, powering electronic devices from alternative energy sources like solar energy [7], thermoenergy [1] or kinetic energy of mechanical vibrations is getting more and more popular. Such techniques usage allows to build electronic devices with working time which is not limited by the built-in conventional energy storage (battery) and without requiring the access to power line. This is very important, for example, in case of wireless sensor network nodes [6], as it assures complete autonomy of the nodes.

To get the fully functional devices powered by the energy harvested from the environment, it is necessary to fulfill two main conditions: the power consumption limiting on the functional side of the devices while maximizing efficiency of harvesting, converting and storing energy on the side of supplying power of the device. The construction of such kind devices requires suitable design methodology [2] (selection of proper technologies and electronic components) as well as adequate methods and tools for measuring and testing. The block diagram of typical device with energy harvesting power supply is presented in Fig. 1.

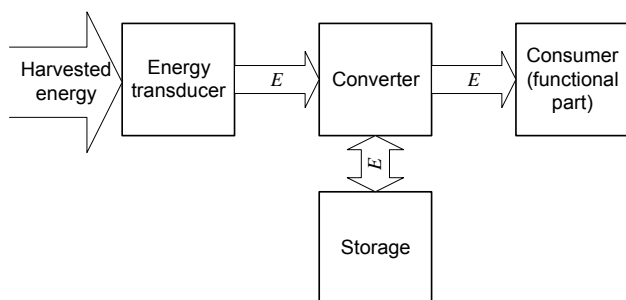

Fig.1. The block diagram of typical energy harvesting device

The energy harvesting device consists of energy transducer (appropriate to the available type of the energy), power converter and power storage and finally the functional part of the device. In every places marked with letter E , there is a need of energy measurement. Energy consumption measurement in such devices is not trivial due to impulse type of energy consumption and very high dynamic of consumed current. The low-power device under discussion is in sleep mode most of the time and current

consumption is on the level of several μA or even below. The device is only waken up periodically to perform measurements and send results wirelessly, which causes an increase of the consumed current up to a few dozens mA or even more.

The measurement of energy consumption of low-power electronic devices is not widely discussed in the literature [3], but this subject is getting more and more popular [4][5]. One of the known methods of energy consumption estimation is based on the measurement of the electric charge consumed by the tested device (or supplied by the tested source or energy converter). The use of the charge integration technique in the above mentioned coulombmeter allows achieving high linearity in a wide measured current range and independence on the shape of the consumed (or supplied) current. In order to test and evaluate the methods and instruments for measurement of micro-energy, there is a need to use the test engine allowing to assure known condition of testing. To fulfill this requirement, the low-power device simulator was proposed and described in the next section.

The simulator concept

The block diagram of the proposed simulator is presented in Fig. 2.

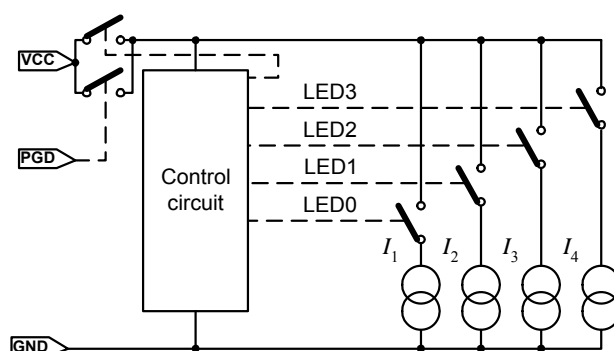

Fig.2. The block diagram of the proposed simulator

The proposed simulator consists of the control circuit and 4 current sources with separately set current values. Each current source can be independently switched on and off by control circuit. The values of current sources can be

set to represent the current consumption by the typical blocks of the low-power electronic device (e.g. analog-digital converter, RF receiver, RF transceiver, CPU, sensor etc.). Different activity modes of the low-power devices can be simulated by appropriate switching on selected current sources. The control circuit checks the readiness of the power supply VCC by examining pin PGD (power good) and in the programmed time moments switches given current sources. This way, the required time characteristic of the current consumption can be obtained. For easier testing the state of each current source is represented by LEDs marked as LED0, LED1, LED2 and LED3. Signal PGD is usually produced by the power converter in the energy harvesting part of the device. Simplified cycle of the simulator was presented in Fig. 3 (the current and the time scale are not preserved).

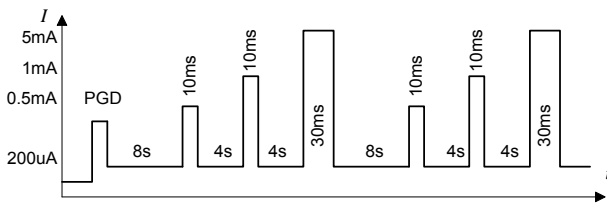

Fig.3. Exemplary profile of current consumption of the proposed low-power device simulator (the current and the time scales are not preserved)

When the power supply given by the harvesting part of the device reaches correct value, the PGD signal is activated switching the supply for control circuit and triggering the simulator to start. The supply for the control circuit can be self-kept. After 8 s first current source (0.5 mA) is switched on to indicated activation of the sensor. After next 4 s, the second current source is switched instead of the first one, to indicate that analog-digital converter was activated. Finally, after next 4 s, the current sources 2 and 4 are switched on to represent RF transmission. Next, the cycle is repeated again.

The prototype realization

The above presented concept of the low-power device simulator was practically implemented and realized. The schematic diagram of the prototype is presented in Fig. 4. The prototype was built using very popular and low-cost microcontroller. The circuit based on MOSFET transistor T1 was used to cut-off the supply and minimize the current consumption when the system is not active (harvesting power supply is not ready – PGD signal is not active). The measured current in the cut-off state was lower than 10 nA.

The simulator starts working when the voltage on PGD terminal is greater than transistor T2 threshold voltage. By setting high state on pin PB4 (SELF_ON), the microcontroller can keep the simulator working (thanks to T3 transistor) as long as the supply voltage VCC is high enough. The PGD input is designed to be driven by the external comparator controlling the supply voltage level. The Zener diode DZ1 protects T2 against overvoltage. The assumed supply voltage range is in a range of 2.6 V up to 5 V. When supply voltage is applied, the microcontroller makes an initialization procedure (switching off all unnecessary peripherals) and setting PB4 high (SELF_ON=1), causing self-kept of the circuit although VCC can drop down due to energy consumption. The microcontroller is clocked by internal RC oscillator, so the operating frequency is equal to 500 kHz. The ATtiny2313 is almost all the time in the sleep mode with active watchdog. The watchdog allows to wake up the CPU for a short time activity. This way, the very low power consumption can be achieved. The measured current in the sleep mode was equal to 4.8 µA and in active mode 203 µA respectively, assuming 3 V supply. The possibility of simulating different states of hypothetical sensor node was assured thanks to the regulated current sources based on LM334 supplying red LEDs: LED0-LED3. Exemplary values of the currents were shown on the schematic diagram. LEDs allows to visually control the state of the device using short flashes. The microcontroller is able to work starting from 1.8 V, but current sources work correctly from 2.6 V. The time of switching on each current source allows to regulate the quantity of the consumed energy.

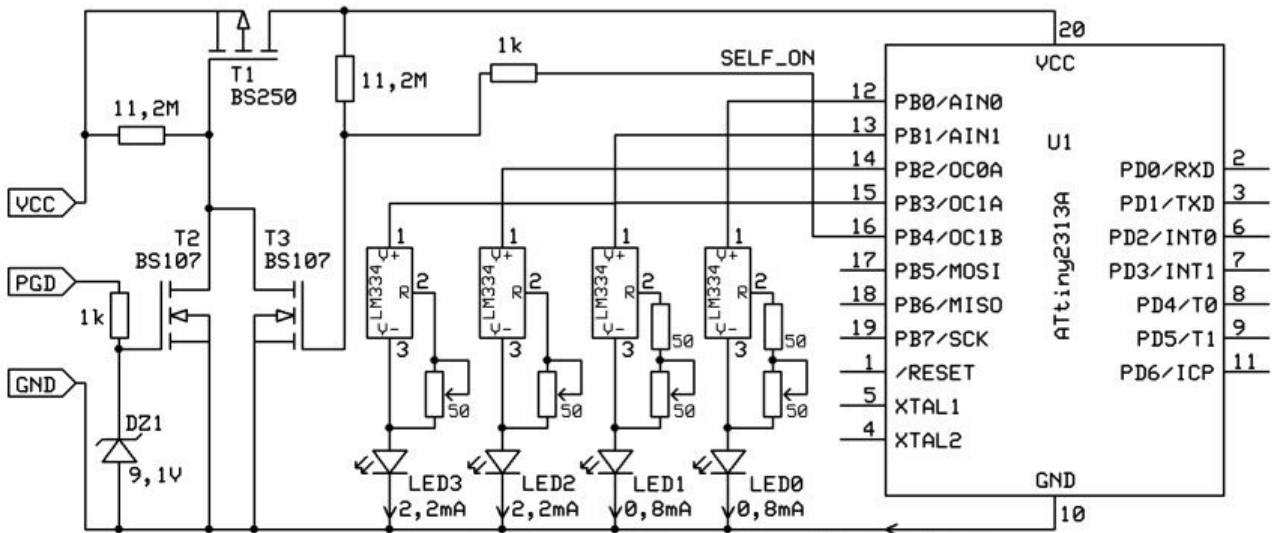

Fig.4. The simplified schematic diagram of the prototype of the proposed simulator of low-power device

Testing of the simulator prototype

The testing of the simulator prototype was performed as shown in Fig. 5. It was tested using supply voltage equal to $V_{CC}=3\text{ V}$ and $V_{CC}=3.7\text{ V}$ in order to check the influence of the supply voltage on energy consumption. To estimate energy we used the micro-charge measurement device based on integrating coulombmeter [8].

Switch SW allows providing signal PGD to start the simulator working. The start of the microcontroller (precisely: end of the microcontroller initialization) was marked by the LED0 flash to allow determine the energy consumption during initialization procedure.

The measurement results for $V_{CC}=3\text{ V}$ were presented in Fig. 6a and for $V_{CC}=3.7\text{ V}$ in Fig. 6b. The graph presents charge consumed by the simulator (black curve) and mean current averaged over each second (red curve).

When analyzing graphs, the moments when the microcontroller simulates required states can be easily noted. The data from the charge meter was sent to the personal computer collecting the data each second, so the mean current value was also calculated over this time as well as over the simulator cycle period.

When comparing the values from the measurements and the values calculated theoretically presented in Table 1 some conclusions can be given. The watchdog block and internal RC oscillator are strongly dependant on the supply

voltage. Mean current consumption for the microcontroller increases as the supply voltage increases. It can be also noted that the assumed mean power consumption ($40\text{ }\mu\text{W}$) was meaningfully changing according to the supply voltage. The cycle period of the simulator was also longer by 2 s then designed and lasted 14 s which was caused by the influence of the watchdog clock frequency on the supply voltage.

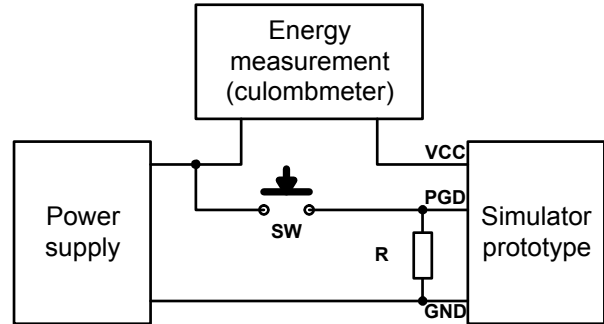

Fig.5. The set-up for testing the simulator prototype

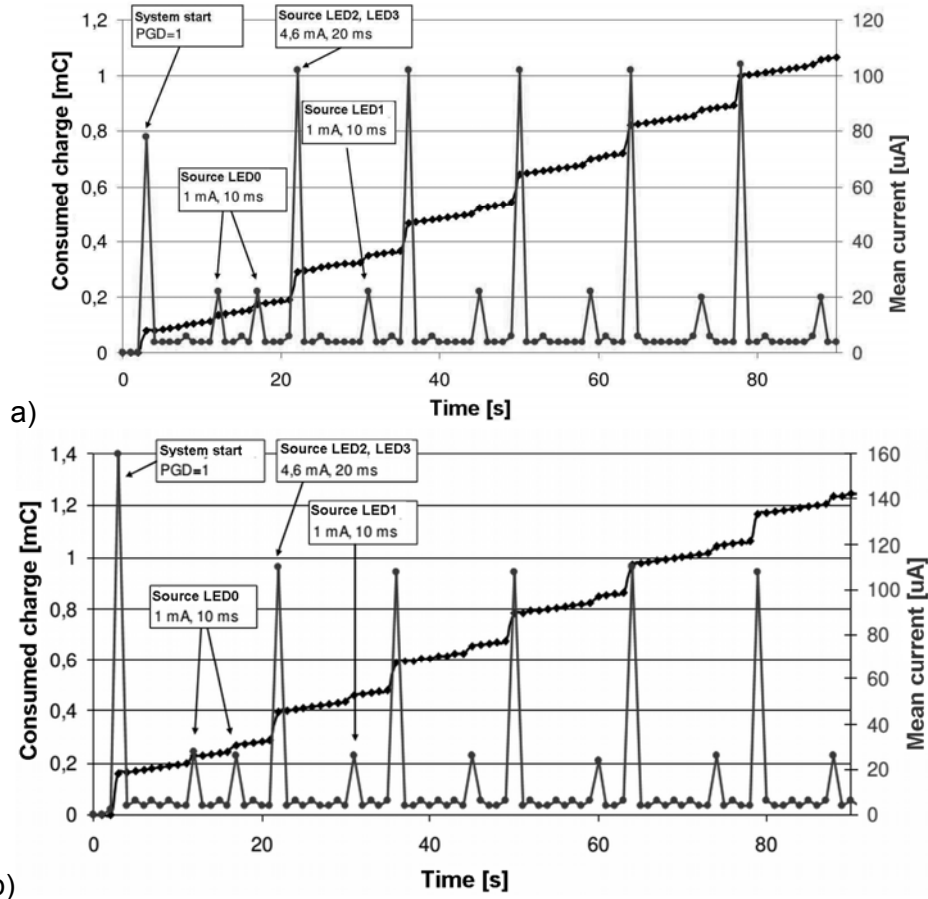

Fig.6. Acquired energy consumption data: mean current consumption over 1 s periods (red) and consumed charge (black) for: a) $V_{CC} = 3\text{ V}$ and b) $V_{CC} = 3.7\text{ V}$

It is worth to note, that some problems with stability of set current values of the current sources was observed. The problem was caused by low-quality multi-turn

potentiometers. Such problem was addressed by Roberta A. Pease [9] as a "finite resolution" of the multi-turn potentiometers.

Table 1. Measured and calculated values of the consumed energy of the proposed simulator prototype

Parameter	Value calculated VCC = 3 V	Value measured in the test set-up	
		VCC = 3 V	VCC = 3.7 V
Mean current over 1s LED1 switched on for 10 ms	14.75 μ A	18 μ A	22 μ A
Mean current over 1s LED2 and LED 3 switched on for 20 ms	96.7 μ A	100 μ A	104 μ A
Mean current consumed by the simulator	13.27 μ A	14.67 μ A	16 μ A
Mean power consumed by the simulator	39.81 μ W	44.01 μ W	59.6 μ W
Charge consumed by the working cycle	159.24 μ C	176 μ C	192 μ C
Energy consumed during initialization	Not determined	234 μ J	592 μ J
Energy consumed during 1 s of sleep mode	14.4 μ J	15.6 μ J	18.5 μ J
Energy consumed by the working cycle	477.7 μ J	528 μ J	710 μ J

Conclusions

The paper presents a concept of the simulator of the low-power device e.g. wireless sensor network node. The idea was verified in the realized and tested prototype which proved the usefulness of the device. The proposed and presented low-power devices simulator can be used for testing energy harvesting supplies as well as methods and instruments for measuring micro-energies. The main advantages of the proposed solution are flexibility of time characteristic of the energy consumption, low cost and simplicity. The consumption characteristic can be regulated in case of current values as well as the time moments when consumption appears.

Authors: mgr inż. Dariusz Palmowski, Gdansk University of Technology, Faculty of Electronics, Telecommunications and Informatics, Department of Metrology and Optoelectronics, ul. Narutowicza 11/12, 80-233 Gdańsk, E-mail: palmowski@eti.pg.gda.pl; dr hab. inż. Grzegorz Lentka, Gdansk University of Technology, Faculty of Electronics, Telecommunications and Informatics, Department of Metrology and Optoelectronics, ul. Narutowicza 11/12, 80-233 Gdańsk, E-mail: lentka@eti.pg.gda.pl; mgr inż. Arkadiusz Hojka, Gdansk University of Technology, Faculty of Electronics, Telecommunications and Informatics, Department of Metrology and Optoelectronics, ul. Narutowicza 11/12, 80-233 Gdańsk, E-mail: arkadiuszhojka@gmail.com

REFERENCES

- [1] Dalola S., Ferrari M., Ferrari V., Guizzetti M., Marioli D., Taroni A., Characterization of Thermoelectric Modules for Powering Autonomous Sensors, *IEEE Transactions on Instrumentation and Measurement*, 58 (2009), n.1, 99-107.
- [2] Eskelinen J., Meyer K., Optimizing Microcontroller Power Efficiency for Ultra Low Power Designs, *Atmel White Paper*, 8223A –AVR –03/09.
- [3] Konstantakos V., Kosmatopoulos K., Nikolaidis S., Laopoulos T., Measurement of Power Consumption in Digital Systems, *IEEE Transactions on Instrumentation and Measurement*, 55 (2006), n. 5, 1662-1670.
- [4] Jiang X., Dutta P., Culler D., Stoica I., Micro Power Meter for Energy Monitoring of Wireless Sensor Networks at Scale, *IPSN'07*, Cambridge, Massachusetts, USA (2007)
- [5] Bucci G., Fiorucci E., Ciancetta F., Luiso M., Measuring System for Microelectric Power, *IEEE Transactions on Instrumentation and Measurement*, 63 (2014), n. 2, 410-421
- [6] Leonov V., Torfs T., Fiorini P., Van Hoof C., Thermoelectric Converters of Human Warmth for Self-Powered Wireless Sensor Nodes, *IEEE Sensors Journal*, 7 (2007), n.5, 650-657
- [7] Nasiri A., Zabalawi A.S., Goran M., Indoor Power Harvesting Using Photovoltaic Cells for Low Power Applications, *IEEE Transactions on Industrial Electronics*, 56 (2009), n.11, 4502-4509
- [8] Lentka G., Palmowski D., Hojka A., Charge consumption measurement of low-power devices using integrating coulombmeter, *11th Scientific Conference „Measurement Systems in Research and in Industry”*, (2016), 93-96
- [9] Pease R.A., Troubleshooting Analog Circuits, *Elsevier*, 1993