

MAGNETIC AND CAPACITIVE COUPLINGS INFLUENCE ON POWER LOSSES IN DOUBLE CIRCUIT HIGH VOLTAGE OVERHEAD TRANSMISSION LINE

Abstract

Purpose – The paper discusses problem of power and energy losses in double circuit overhead transmission line. It was observed from energy meters readings, that in such line an active power losses can be measured as ‘negative’. The ‘negative’ active power losses appears when the active power injected to the circuit is lower than the active power received at the circuit end. The purpose of this paper is to explain this phenomenon.

Design/methodology/approach – There are presented theoretical considerations based on mathematical model of the transmission line of π -type confirming that effect. There are calculated power losses related to series impedance of the line and to shunt admittance. The theoretical considerations are confirmed by measurements done on the real transmission line.

Findings – The calculations allow to indicate components of the active power losses, i.e. related to electromagnetic coupling among wires of a given circuit, related to electromagnetic coupling between circuits, and related to shunt capacitance asymmetry. The authors indicate influence of the line/wires geometry on the active power losses in a double circuit overhead transmission line.

Originality/value – Explanation of the effect of ‘negative’ active power losses measurement in double circuit overhead transmission line.

Keywords – Transmission lines, power losses, power and energy measurement.

Paper type – Research paper

I. INTRODUCTION

Double circuit high voltage overhead transmission lines are characterized by interesting phenomenon related to power and energy measurement. Energy and power flow in such transmission lines can show ‘negative’ losses while comparing power or energy at the both ends of the line’s circuits. The ‘negative’ power losses mean here state in which power injected to the circuit is lower than power at the receiving end. Of course when the both circuits operate in parallel the total amount of power at the receiving node is always lower that at the injection node.

The problem discussed in the paper is important when the transmission line operates as interconnector between two countries and when the line at some length is multi-circuit and next split and connect to the two various power systems (related to energy buying/selling). The paper explains the “negative losses” phenomenon and shows some factors influencing the effect.

The paper considers the double circuit 400 kV transmission line of length 164 km, which connects the Western and Central European electricity network (ENTSO-E) with the Baltic States networks via back to back (BtB) converter station Robak and Wasilewski (2012). Each circuit is equipped with two shunt reactors SR_A and SR_B located at both ends of the line (substation A and substation B). The shunt reactors of rating 50 Mvar at substation A, and 72 Mvar at substation B are designed to provide line reactive power (charging power) compensation Klucznik *et al.* (2015), Lubosny *et al.* (2015), Klucznik *et al.* (2014). The transmission line connection diagram is shown in Fig. 1.

The calculations were done analytically and with use of DlgSILENT PowerFactory® software. The transmission line is modelled as three π -sections connected in series. Each section, of length equal to 1/3 of the total line length, is represented by two three-phase, coupled circuits with overhead earth wires. The line is transposed to limit its asymmetry, i.e. phase wire sequence changes for each section. The line model includes electromagnetic couplings as well as capacitive couplings between circuits Greenwood (1991). The line parameters are calculated directly from the transmission tower geometry and the conductors data sheets Gonen (2014).

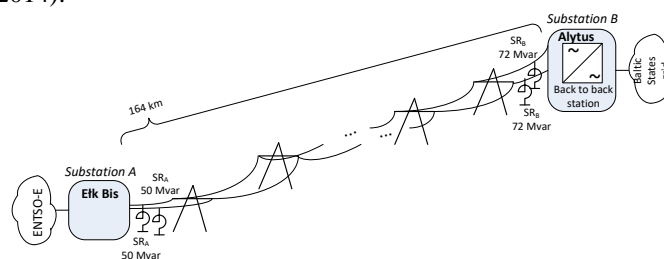

Fig.1. Schematic diagram of the Elk Bis – Alytus double-circuit 400 kV overhead transmission line.

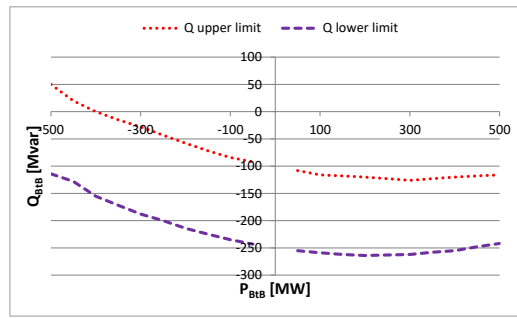

Fig.2. Alytus BtB substation characteristics.

BtB station of rated power 500 MW, located in Lithuania in Alytus, is characterized by operating area as presented in Fig. 2. The operating area is limited by reactive power $Q_{upperlimit}$ and $Q_{lowerlimit}$ that are resulted from the power electronics converter operation. In power operation range $-50 \div 50$ MW the characteristics are discontinuous, because transfer of active power below 10% of the nominal converter capacity is not possible.

At the Polish side of the converter substation there are located three reactive power sources (Fig. 6): capacitor bank C1 (48 Mvar) and two filters F1 (72 Mvar), F2 (72 Mvar). Their operation (on/off state) depends on the active power flow. For active power flow below 105 MW only one filter (F1) is switched on. When the transmitted power is higher than 105 MW the BtB substation operates with two filters (F1, F2) switched on, while for active power exceeding 380 MW the additional capacitor bank (C1) is switched on.

The paper contains theoretical considerations related to the discussed phenomenon. Furthermore there are presented results of measurements carried out in the real transmission line. The measurement results are compared to the results of calculation performed with the use of mathematical model of the line and are discussed.

II. POWER LOSSES IN DOUBLE CIRCUIT TRANSMISSION LINE

Let's consider three phase double circuit (with six phase wires and two overhead ground wires) transmission line. Power flow at the line 'from' bus for each phase is equal to

$$\underline{S}_{from,i} = \underline{V}_{from,i} \cdot \underline{I}_{from,i}^* \quad (1)$$

while power flow at the line 'end' bus at each phase is equal to

$$\underline{S}_{end,i} = \underline{V}_{end,i} \cdot \underline{I}_{end,i}^* \quad (2)$$

where $\underline{V}_{from,i}$, $\underline{V}_{end,i}$, $\underline{I}_{from,i}^*$, $\underline{I}_{end,i}^*$ are respectively i -th phase voltages and i -th conjugate of currents at 'from' and 'end' bus.

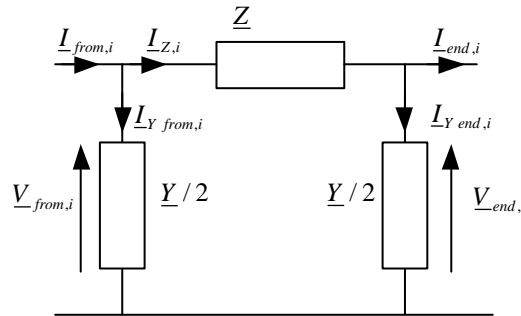

Fig.3. π -type model of the transmission line.

Assuming the π -type model of the transmission line (Fig. 3), i.e. mathematical model comprises series impedances \underline{Z} and shunt admittances $\underline{Y}/2$ 'located' at both ends of the series impedance \underline{Z} , the currents (in form of vectors) flowing in series impedance are related to the 'from' and 'end' bus currents as follows

$$\underline{I}_Z = \underline{I}_{from} - \underline{I}_{Y from} = \underline{I}_{end} + \underline{I}_{Y end} \quad (3)$$

The line power losses $\Delta \underline{S}$ in such circuit can be split into losses related to series impedance \underline{Z} and to shunt admittance \underline{Y}

$$\Delta \underline{S} = \Delta \underline{S}_Z + \Delta \underline{S}_Y \quad (4)$$

Power losses related to series impedance $\Delta \underline{S}_Z$, can be calculated as follows.

For the considered system the voltage drop across the each phase wire is equal to

$$\Delta \underline{V} = \underline{Z} \cdot \underline{I}_Z \quad (5)$$

where: $\Delta \underline{V} = [\Delta V_1 \quad \Delta V_2 \quad \Delta V_3 \quad \Delta V_4 \quad \Delta V_5 \quad \Delta V_6]^T$ - vector of phase wires voltage drops

$$\underline{I}_Z = [\underline{I}_1 \quad \underline{I}_2 \quad \underline{I}_3 \quad \underline{I}_4 \quad \underline{I}_5 \quad \underline{I}_6]^T \quad \text{- vector of phase wires currents,}$$

$$\underline{Z} = \begin{bmatrix} \underline{Z}_{11} & \cdots & \underline{Z}_{16} \\ \vdots & \ddots & \vdots \\ \underline{Z}_{61} & \cdots & \underline{Z}_{66} \end{bmatrix} \quad \text{- matrix of self and mutual impedances}$$

Ground wires are included indirectly in matrix \underline{Z} . Matrix \underline{Z} is the reduced form of the multi-conductor system, where the ground wires are eliminated (using Kron reduction) leaving only the six phase conductors.

The phase wire voltage drop $\Delta \underline{V}$ is also equal to

$$\Delta \underline{V} = \underline{V}_{from} - \underline{V}_{end} \quad (6)$$

Power losses on series impedance of the line in the each wire are then equal to

$$\Delta \underline{S}_{Z,i} = \Delta \underline{V}_i \cdot \underline{I}_i^* \quad (7)$$

The total power losses in circuit I, i.e. in wires 1, 2, 3, assuming that $\underline{Z}_{13} = \underline{Z}_{31}$, $\underline{Z}_{23} = \underline{Z}_{32}$, $\underline{Z}_{12} = \underline{Z}_{21}$ are equal to

$$\Delta \underline{S}_{ZI} = \underline{I}_1^* \underline{I}_1 \underline{Z}_{11} + \underline{I}_2^* \underline{I}_2 \underline{Z}_{22} + \underline{I}_3^* \underline{I}_3 \underline{Z}_{33} + (\underline{I}_2^* \underline{I}_1 + \underline{I}_1^* \underline{I}_2) \underline{Z}_{12} + (\underline{I}_3^* \underline{I}_1 + \underline{I}_1^* \underline{I}_3) \underline{Z}_{13} + (\underline{I}_3^* \underline{I}_2 + \underline{I}_2^* \underline{I}_3) \underline{Z}_{23} + \underline{I}_1^* (\underline{I}_4 \underline{Z}_{14} + \underline{I}_5 \underline{Z}_{15} + \underline{I}_6 \underline{Z}_{16}) + \underline{I}_2^* (\underline{I}_4 \underline{Z}_{24} + \underline{I}_5 \underline{Z}_{25} + \underline{I}_6 \underline{Z}_{26}) + \underline{I}_3^* (\underline{I}_4 \underline{Z}_{34} + \underline{I}_5 \underline{Z}_{35} + \underline{I}_6 \underline{Z}_{36}) \quad (8)$$

while the total power losses in circuit II, i.e. in wires 4, 5, 6, assuming that $\underline{Z}_{45} = \underline{Z}_{54}$, $\underline{Z}_{46} = \underline{Z}_{64}$, $\underline{Z}_{56} = \underline{Z}_{65}$ are equal to

$$\Delta \underline{S}_{ZII} = \underline{I}_4^* \underline{I}_4 \underline{Z}_{44} + \underline{I}_5^* \underline{I}_5 \underline{Z}_{55} + \underline{I}_6^* \underline{I}_6 \underline{Z}_{66} + (\underline{I}_5^* \underline{I}_4 + \underline{I}_4^* \underline{I}_5) \underline{Z}_{45} + (\underline{I}_6^* \underline{I}_4 + \underline{I}_4^* \underline{I}_6) \underline{Z}_{46} + (\underline{I}_6^* \underline{I}_5 + \underline{I}_5^* \underline{I}_6) \underline{Z}_{56} + \underline{I}_4^* (\underline{I}_1 \underline{Z}_{41} + \underline{I}_2 \underline{Z}_{42} + \underline{I}_3 \underline{Z}_{43}) + \underline{I}_5^* (\underline{I}_1 \underline{Z}_{51} + \underline{I}_2 \underline{Z}_{52} + \underline{I}_3 \underline{Z}_{53}) + \underline{I}_6^* (\underline{I}_1 \underline{Z}_{61} + \underline{I}_2 \underline{Z}_{62} + \underline{I}_3 \underline{Z}_{63}) \quad (9)$$

Next, assuming that currents in the both circuits are symmetrical (RMS current is equal to I), i.e.

$$\begin{aligned} \underline{I}_1 &= \underline{I}_4 = I \\ \underline{I}_2 &= \underline{I}_5 = I \cdot a^2 \\ \underline{I}_3 &= \underline{I}_6 = I \cdot a \end{aligned} \quad (10)$$

where $a = e^{j120^\circ} = -\frac{1}{2} + j\frac{\sqrt{3}}{2}$, and $a^2 = e^{j240^\circ} = -\frac{1}{2} - j\frac{\sqrt{3}}{2}$ are operators of rotation, equations (7) and (8) take a form

$$\Delta \underline{S}_{ZI} = I^2 \left((\underline{Z}_{11} + \underline{Z}_{22} + \underline{Z}_{33} - \underline{Z}_{12} - \underline{Z}_{13} - \underline{Z}_{23}) + (\underline{Z}_{14} + a^2 \underline{Z}_{15} + a \underline{Z}_{16} + a \underline{Z}_{24} + \underline{Z}_{25} + a^2 \underline{Z}_{26} + a^2 \underline{Z}_{34} + a \underline{Z}_{35} + \underline{Z}_{36}) \right) \quad (11)$$

$$\Delta \underline{S}_{ZII} = I^2 \left((\underline{Z}_{44} + \underline{Z}_{55} + \underline{Z}_{66} - \underline{Z}_{45} - \underline{Z}_{46} - \underline{Z}_{56}) + (\underline{Z}_{41} + a^2 \underline{Z}_{42} + a \underline{Z}_{43} + a \underline{Z}_{51} + \underline{Z}_{52} + a^2 \underline{Z}_{53} + a^2 \underline{Z}_{61} + a \underline{Z}_{62} + \underline{Z}_{63}) \right) \quad (12)$$

The first component in equations (11) and (12) is a measure of power losses resulted from electromagnetic coupling among wires of a given circuit. For example, assuming single circuit (e.g. circuit I) with full symmetry, i.e. $\underline{Z}_{11} = \underline{Z}_{22} = \underline{Z}_{33} = \underline{Z}_o$ and $\underline{Z}_{12} = \underline{Z}_{13} = \underline{Z}_{23} = \underline{Z}_m$ the circuit power losses are equal to $\Delta \underline{S} = 3I^2(\underline{Z}_o - \underline{Z}_m)$ where impedance $\underline{Z}_o - \underline{Z}_m$ is known as positive sequence impedance of the line.

Coming back to the double circuit line one can say that the second component in equations (11) and (12) is some measure of electromagnetic couplings between the circuits.

The influence of the both components on the power losses is presented in Fig. 4. The active power losses related to series impedance \underline{Z} are marked as $P_{ZI} = \text{Re}(\Delta \underline{S}_{ZI})$, $P_{ZII} = \text{Re}(\Delta \underline{S}_{ZII})$. Their components related to electromagnetic couplings among wires in a given circuit (the first component in equations (11) and (12)) are marked as P_{ZIa} , P_{ZIIa} while components related to electromagnetic couplings between circuits (the second component in equations (11) and (12)) are marked as P_{ZIIb} , P_{ZIIb} . One can see here that the losses increase when the power transfer increases (they are related to the current square). But additionally one can notice that the losses value P_{ZI} and P_{ZII} in the both circuits differs. The difference reaches almost 2 MW (about 40%) for power transfer equal to 500 MW. One can notice here also that the power losses component related to electromagnetic couplings in the circuit for both circuits P_{ZIa} , P_{ZIIa} are the same, while the losses component related to couplings between circuits P_{ZIIb} , P_{ZIIb} have various signs, i.e. are positive for circuit I and negative for circuit II. This shows direction of energy flow between circuits, and at the same time explain difference in the power losses P_{ZI} , P_{ZII} in the both circuits.

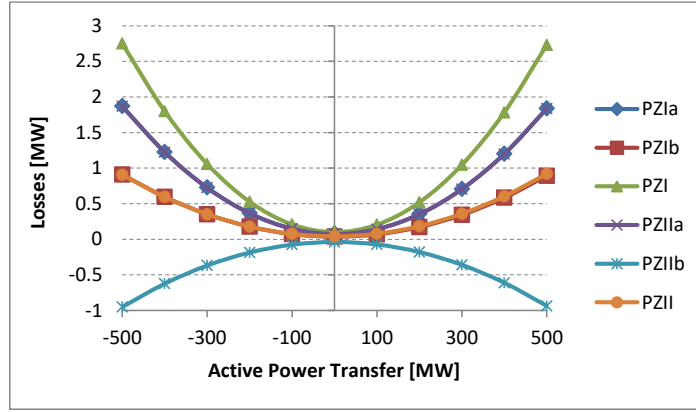

Fig.4. Power losses related to series element (impedance Z) of the transmission line as function of transferred power.

The second component of the transmission line power losses in equations (11) and (12) is related to shunt admittance ΔS_Y . The losses are related to shunt conductance (mainly the corona effect) and to shunt capacitance. The power losses on each (i -th) wire, are equal to

$$\Delta S_{Y,i} = \Delta S_{Y_{from,i}} + \Delta S_{Y_{end,i}} = V_{from,i} \cdot I_{Y_{from,i}}^* + V_{end,i} \cdot I_{B_{end,i}}^* \quad (13)$$

where $I_{Y_{from,i}}^*$ and $I_{Y_{end,i}}^*$ are shunt conjugate of currents at the both line ends. The currents, in form of vector, are calculated as follows:

$$I_{Y_{from}} = \frac{1}{2} \underline{Y} \cdot \underline{V}_{from} \quad (14)$$

$$I_{Y_{end}} = \frac{1}{2} \underline{Y} \cdot \underline{V}_{end} \quad (15)$$

where:

$$\underline{Y} = \begin{bmatrix} Y_{11} & \cdots & Y_{16} \\ \vdots & \ddots & \vdots \\ Y_{61} & \cdots & Y_{66} \end{bmatrix} = \begin{bmatrix} G_{11} + jB_{11} & \cdots & G_{16} + jB_{16} \\ \vdots & \ddots & \vdots \\ G_{61} + jB_{61} & \cdots & G_{66} + jB_{66} \end{bmatrix} \quad \text{-- matrix of self and mutual admittances.}$$

Assuming full voltage symmetry at the beginning of the transmission line:

$$\begin{aligned} V_{from,1} &= V_{from,4} = V_{from} \\ V_{from,2} &= V_{from,5} = V_{from} \cdot a^2 \\ V_{from,3} &= V_{from,6} = V_{from} \cdot a \end{aligned} \quad (16)$$

and for simplicity neglecting conductances G_{ij} , the shunt current for the wire 1 of circuit I at 'from' bus (as example) is equal to

$$I_{Y_{from,1}} = (V_{from,1}B_{11} - V_{from,2}B_{12} - V_{from,3}B_{13} - V_{from,4}B_{14} - V_{from,5}B_{15} - V_{from,6}B_{16})/2 = V_{from}(jB_{11} - jB_{12}a^2 - jB_{13}a - jB_{14} - jB_{15}a^2 - jB_{16}a)/2 \quad (17)$$

After further simplifications the equation (13) takes a form

$$I_{Y_{from,1}} = \frac{\sqrt{3}}{4} V_{from} (-B_{12} + B_{13} - B_{15} + B_{16}) + j \frac{1}{4} V_{from} (2B_{11} + B_{12} + B_{13} - 2B_{14} + B_{15} + B_{16}) \quad (18)$$

with two components: active and reactive. The shunt current active component can be positive or negative depending on expression $(-B_{12} + B_{13} - B_{15} + B_{16})$ sign. For most of typical transmission towers it is not equal zero. It means that for typical transmission line, including the one considered in the paper, a small amount of active power losses can be expected due to line's capacitance asymmetry. The corresponding active power losses of the first wire 1 of circuit I is equal to:

$$\Delta P_{Y1} = \frac{\sqrt{3}}{4} V_{from}^2 (-B_{12} + B_{13} - B_{15} + B_{16}) \quad (19)$$

Active power for other wires can be calculated in similar way. Similar equations are valid for the end bus of the line. The difference is related here to different voltage magnitude at the 'end' bus V_{end} . In fact one can expect asymmetry of the voltages at the 'end' bus as well.

The total active power for the circuit is sum of power of individual wires. For circuit I and circuit II, with simplification that $V_{from} \cong V_{end}$ it is equal to

$$\Delta P_{BI} = \frac{\sqrt{3}}{2} V_{from}^2 (-B_{15} + B_{16} + B_{24} - B_{26} - B_{34} + B_{35}) \quad (20)$$

$$\Delta P_{BII} = \frac{\sqrt{3}}{2} V_{from}^2 (B_{51} - B_{61} - B_{42} + B_{62} + B_{43} - B_{53}) \quad (21)$$

The active power losses in the two circuits of the transmission line are equal in value, but have an opposite sign, what is resulted from $B_{ij} = B_{ji}$. This means, that if the both circuits of the line are considered together, the capacitance asymmetry does not cause additional losses of active power, which is consistent with the laws of physics.

When the circuits are considered separately, additional positive or negative active power can be expected for the both circuits. If power/energy meters are installed separately for the both circuits (which is a common practice for cross-border transmission lines) their readings will show a difference in the measured active power (energy).

The above consideration allows for calculation of power losses components for any transmission line. Figure 5 presents results of active power losses calculation for the considered overhead transmission line. It can be seen, that the series losses (repetition of Fig. 4) differs for the both circuits. They are significantly larger in circuit I than in circuit II. This means, that part of power (energy) flows from the circuit I to circuit II. Additionally, the shunt capacitances introduces negative power losses to circuit I and positive to circuit II. Total active power losses for circuit I therefore are negative, while total active power losses for circuit II are positive. The transmission line total losses (circuits measured together) are positive as it is expected.

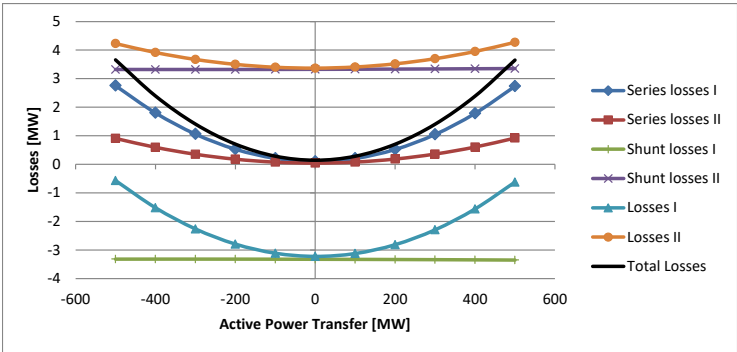

Fig 5. Active power losses for the double circuit overhead transmission line as function of transferred power.

III. COMPARISON OF REAL MEASUREMENTS AND TEST RESULTS

In this section reading from real meters installed in the considered transmission line are compared to results obtained from detailed model of part of Polish power system. Presented results are calculated by DIGSILENT PowerFactory® software.

Figure 6 presents calculated power flows in the considered system for two study cases related to 500 MW power transfer through BtB substation. Case W01 is related to power transfer from Lithuania to Poland, while case W02 is related to power transfer in opposite direction. One can see here that in the both cases the power losses in circuit I (defined as difference of sending and receiving power of the circuit) are below zero.

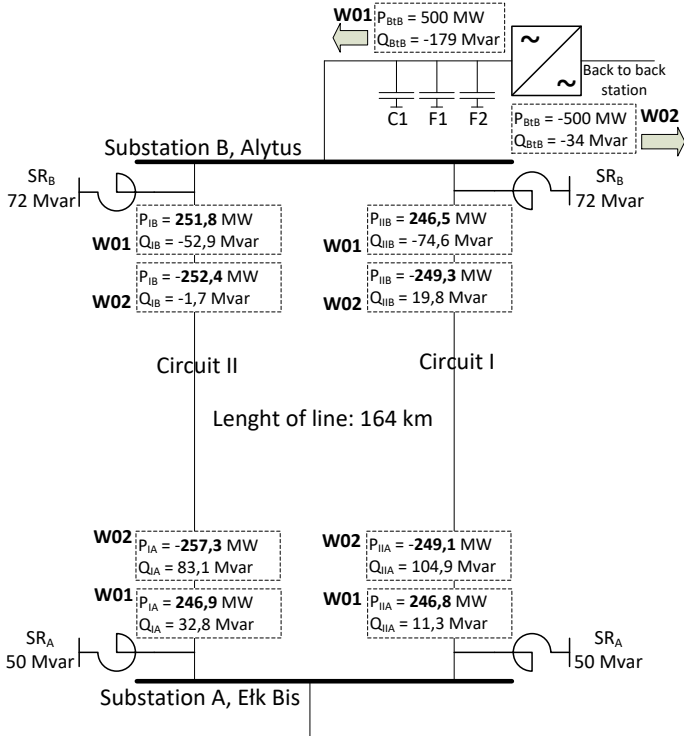

Fig.6. Load flows in the considered system (Cases: W01 – power flow from Alytus to Elk Bis, W02 – power flow from Elk Bis to Alytus).

The above mentioned effect is also presented in Fig. 7, which shows the calculated power losses in the both circuits as a function of the BtB substation active power flow. The curves are calculated for mean value of BtB reactive power presented in

Fig. 2. The visible curves distortion in range ± 150 MW are related to the filter F2 switching off for low active power transfer, as previously described. Transfer of active power below 10% of nominal converter capacity is not possible, therefore characteristics are discontinuous.

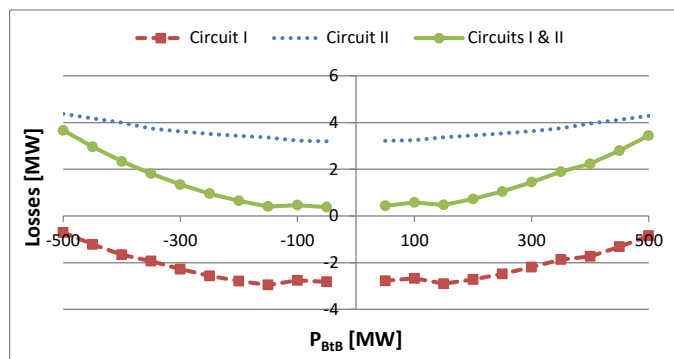

Fig.7. Active power losses in line Elk Bis – Alytus as function of power transfer through Alytus BtB substation.

Readings from metering system in substations Elk Bis and Alytus confirms above calculation results. At the same time, these readings cause concern for Polish and Lithuanian Transmission System Operators for the proper operation of metering systems and appropriate accounting of electrical energy exchange. Figure 8 presents comparison between calculated and measured values of the active power losses. Solid lines represent interpolation of the measurements (trend line) while the dashed lines represent results of calculation based on mathematical model. There is visible some correlation among the curves. The differences between calculated and measured values, decrease as active power transfer increases. The difference is a result of measurement error dependency on transferred power, caused mainly by current transformers and result also of difference in shunt conductance applied in the model and represented in the real system (corona effect related to voltage and weather conditions).

In general one can say that the model and the considerations presented in Chapter II imitate reality in acceptable level and explain the problem of ‘negative’ losses of active power in overhead transmission line.

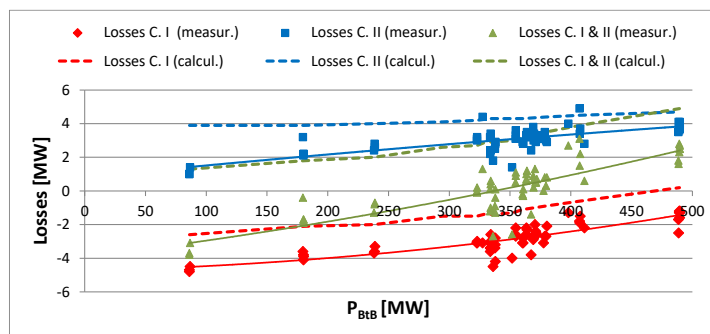

Fig.8. Comparison of active power losses in line Elk Bis – Alytus (measured vs calculated)

III. TRANSPOSITION AND PHASE SEQUENCE INFLUENCE ON ACTIVE POWER LOSSES

As it was mentioned above the effect of ‘negative’ losses of active power in single circuit of double circuit transmission line is related to electromagnetic and capacitive couplings in the line. The circuits symmetrisation can eliminate the effect. But the phase wires location is designed to decrease the voltages asymmetry in the considered line, Robak and Wasilewski (2012).

Figure 9 presents the wires location along the considered real transmission line. Letters A, B, C define phase wires. Circuit I contains wires located on the left side of tower, while circuit II contains wires located on the right side of the tower. Segments presented in the Fig. 9 are element of the line transposition.

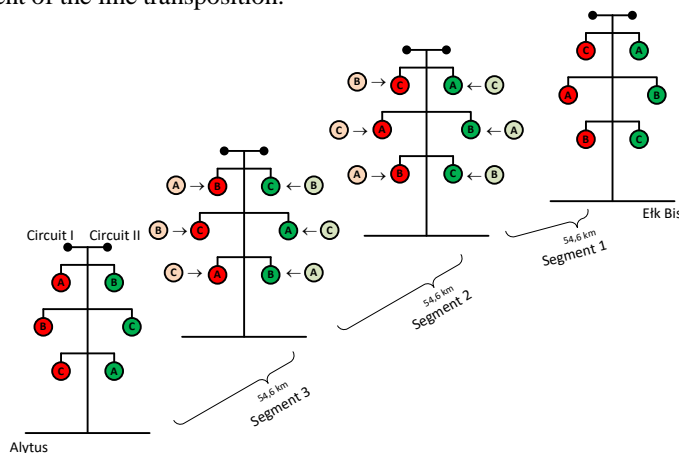

Fig. 9. Phase sequence and transpositions for transmission line Elk – Alytus (existing state).

The line transposition Badaway *et al.* (1982), Mooney (2010) is applied to minimize voltage asymmetry in the system. The transposition is not obligatory but it is rather related to maximum allowed by grid code level of negative sequence voltage introduced by the line, which is measure of asymmetry. Then in Fig. 10 there is shown influence of the considered line transposition on the active power losses. There is presented comparison of the losses for line transposed (existing state) and not transposed. One can see here that in the considered example the active power losses difference for the two cases are extremely low. Then one can conclude that transposition is not a key element of the line design from the viewpoint of active power losses.

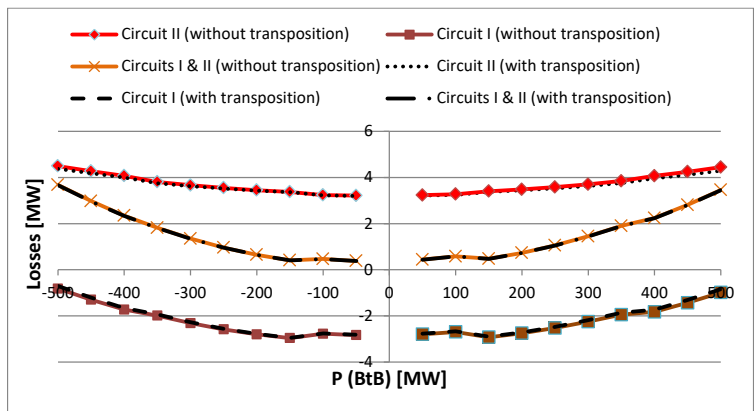

Fig. 10. Active power losses for line with and without transposition.

Various location of phase wires of the both circuits lead to various capacitances among wires and earth and to various mutual impedances among wires of various circuits. Table I presents locations of phase wires of exemplary double circuits transmission lines for 7 cases, named as CPS1-CPS6 and *current* (real line). The letters define phase counted from the tower bottom, beginning in Elk Bis substation. For example, for line named in Tab. I as ‘current’ the circuit I has phase wires sequence BAC and circuit II has CBA what is visible in Fig. 9 at Elk Bis substation. Phases B for circuit I and C for circuit II are located at bottom (closest to earth).

Tab. I. Cases of phase wires location in overhead transmission line.

Case of wires phase sequence	Segment 1		Segment 2		Segment 3	
	Circuit I	Circuit II	Circuit I	Circuit II	Circuit I	Circuit II
Current	BAC	CBA	ACB	BAC	CBA	ACB
CPS1	CBA	ACB	BAC	CBA	ACB	BAC
CPS2	ACB	BAC	CBA	ACB	BAC	CBA
CPS3	BAC	ACB	ACB	CBA	CBA	BAC
CPS4	BAC	BAC	ACB	ACB	CBA	CBA
CPS5	CBA	ACB	CBA	ACB	CBA	ACB
CPS6	ACB	BAC	ACB	BAC	ACB	BAC

Results of the active power losses calculation for the cases from Tab. I are presented in Fig. 11. The power losses are presented separately for circuit I and II. One can see here that the active power losses for cases CPS1, CPS2, CPS5, CPS6 dependence from BtB station power flow are similar to the real line case (named current). In case CPS3 the effect is opposite to the presented for real line and cases CPS1, CPS2, CPS5, CPS6 what means that the ‘negative’ losses of power are related to circuit II. Case CPS4 differs from the other because in this case the wires of circuit I and II are located symmetrically along tower. In this case the mutual impedances between circuits and also capacitances among wires of the both circuits are the same. This lead to symmetrical system which results in the same power losses in both circuits. And in it, the effect of ‘negative’ losses does not appear.

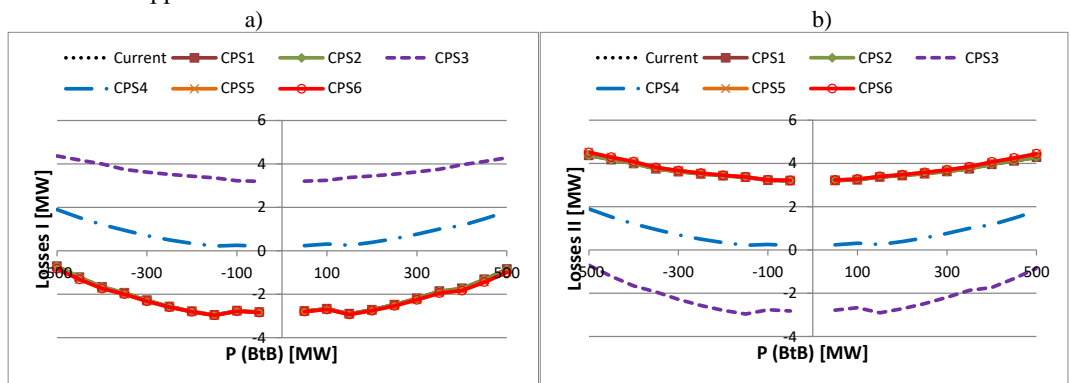

Fig. 11. Active power losses for different phase sequence, a) Circuit I, b) Circuit II.

IV. CONCLUSIONS

Negative difference between sent and received active power can be expected for single circuit of double circuits transmission lines. This phenomenon was observed for transmission line connecting Poland and Lithuania. The phenomenon is caused by asymmetry of electromagnetic and capacitive couplings between circuits.

Phase wire sequence influences on distribution of power losses between circuits. It is possible to reduce phenomenon by proper selection of phase sequence.

REFERENCES

- Badawy E. H., Said M. M., Nour H. I. (1982), "Electromagnetic unbalance in power systems with untransposed transmission lines", *Electric Power Systems Research*, Volume 5, Issue 4, December 1982, Pages 253-258.
- Gonen T. (2014), *Electrical Power Transmission System Engineering: Analysis and Design, Third Edition*, CRC Press.
- Greenwood A. (1991), „Electrical Transients in Power Systems”, *2nd Edition*, Wiley-Interscience, New York, NY.
- Klucznik J., Lubosny Z., Dobrzynski K., Czapp S. (2015), „Nonlinear secondary arc model use for evaluation of single pole auto-reclosing effectiveness”, *COMPEL: The International Journal for Computation and Mathematics in Electrical and Electronic Engineering*, Vol. 34 Iss 3 pp. 647-656, <http://dx.doi.org/10.1108/compel-10-2014-0252>
- Klucznik J., Lubosny Z., Dobrzynski K., Czapp S., Kowalak R., Malkowski R. (2014), „Case Studies of Resonance Phenomena in High Voltage Overhead Power Lines with Shunt Reactors”, *The Sixteenth Biennial IEEE Conference on Electromagnetic Field Computation*, CEFC, France.
- Lubosny Z., Klucznik J., Dobrzynski K. (2015), „The Issues of Reactive Power Compensation in High-voltage Transmission Lines”, *Acta Energetica*, Vol. 2/23, pp. 102-108, DOI: 10.12736/issn.2300-3022.2015210.
- Mooney J. B. (2010), "Economic analysis and justification for transmission line transposition", *IEEE PES Transmission and Distribution Conference and Exposition: Smart Solutions for a Changing World*, New Orleans, LA
- Robak, S. Wasilewski, J. (2012), "Voltage and current asymmetry analysis in Poland – Lithuania link", *Energetyka*, No. XXIII, pp. 61-65 (in Polish)

