

On the use of a charge balancing method for low energy measurements

Abstract. The paper presents the method for the estimation of the energy consumption of the low-power microcontroller-based devices. Due to high dynamics of the changes of the supply current of the tested devices during the operational cycle, the consumed energy estimation is not easy. In order to avoid disadvantages of known methods, the charge balancing method was employed similarly like in some types of A/D converters.

Streszczenie. W pracy przedstawiono propozycję sposobu oceny energii pobieranej przez niskomocowe urządzenia mikrokontrolerowe. Ze względu na dużą dynamikę zmian prądu zasilania podczas cyklu pracy urządzenia, oszacowanie pobranej energii nie jest łatwe. W celu uniknięcia wad dotychczasowych rozwiązań zaproponowano wykorzystanie metody równoważenia ładunku podobnie jak ma to miejsce w wybranych typach przetworników a/c. (**Wykorzystanie metody równoważenia ładunku do pomiaru małych energii**).

Keywords: micro-energy measurement, energy consumption minimalization, charge balancing method, low-power devices.

Słowa kluczowe: pomiar mikroenergii, mimalizacja poboru mocy, metoda równoważenia ładunku, urządzenia mikromocowe.

Introduction

Figure 1 presents the architecture of typical low-power device based on microcontroller [1]. Typical applications include sensor network nodes, elements of the installation smart home, recorders of transport conditions, systems for monitoring various parameters [2-5].

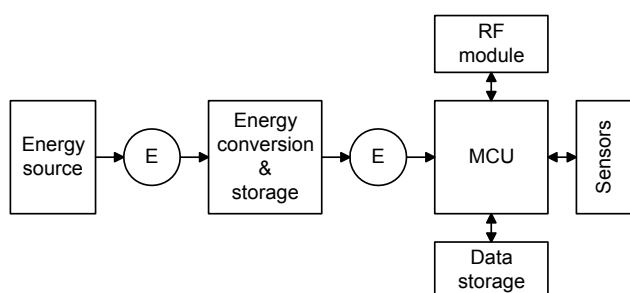

Fig. 1. Block diagram of the low-power microcontroller-based device

The device consists of the microcontroller (MCU) with extended energy saving modes, group of sensors allowing to measure required set of parameters and controlled by the MCU, low-power wireless communication module (usually operating at radio frequencies) and optional non-volatile data storage for keeping the acquires sensors data locally when the communication is not available or unjustifiable from the energetic point of view. Important part of the device is an energy source in form of a classical electrochemical battery or a modern Energy Harvesting (EH) module collecting the energy available in the environment and supplying it to the rest of the device. Collecting different energy forms (like solar energy, kinetic energy, the energy of mechanical vibrations or electromagnetic field) [6] enables the construction that do not require conventional power sources. This is possible under the condition of efficient energy processing and storing which is provided by the last block shown on Fig. 1. Efficient energy harvesting requires a converter converting other forms of energy into electrical energy. Depending on the energy form available, it may be a piezoelectric element (vibration), antenna (EM field), set of thermocouples (temperature difference) or photovoltaic cell (sunlight). In many cases, the system can have more than one type of energy converter to be more flexible. Usually the energy conversion and storage block includes specialized DC/DC converter adjusting the source voltage level to the required

level by the micropower system. Energy storage can be obtained, in the simplest case, if access to energy is continuous, using capacitor. If access to energy is irregular, supercapacitors or electrochemical cell recharged during periods of surplus energy can be used.

The proper design process of the aforementioned low-power microcontroller-based devices powered with batteries as well as EH requires intensive minimalization of energy consumption. Lower energy consumption allows longer devices live due to battery limitation. When using energy harvesting techniques, the power consumption lowering is also profitable as it allows decreasing the size of the energy harvester (e.g. photovoltaic cell surface) as well as the size of the energy reservoir (e.g. supercapacitor). This requires careful hardware construction as well as software procedures optimisation.

The knowledge of quantity of energy provided by the selected energy transducer in the assumed work conditions is also necessary [7]. The mechanical properties, such as the method of fixing or the resonance of the mechanical converter have an essential influence on the amount of collected energy. The simplest method is the experimental verification in the specific application conditions.

Thus, the energy measurement is required at the each connection (on Fig.1. it was marked as „E”) to estimate the effectiveness of the energy harvesting, conversion, storage and the quantity of the energy consumption (allowing to evaluate the quality of low-power design).

Precise estimation of the quantity of the energy consumed by the device or supplied by the transducer is not trivial due to the work characteristic of each block of the device and properties of the measured signal. There are some literature proposals for an estimation of energy demand of low-power devices [8, 9]. The paper presents the proposal of the energy measurement device based on the charge balancing method.

Micro energy measurement methods background

The typical average power consumption the low-power system is given in microwatts. Such low power consumption can be achieved even using standard microcontrollers, because the MCU for most of the time is in power-saving mode and majority of peripheral devices do not work. Normal activity state occurs relatively seldom and lasts short time - a small percentage of the time. The mentioned situation causes accurate measurement of the energy consumed by a typical micropower system to be problematic. The measuring device must have a large

dynamic range as the measured currents can vary by at least two orders of magnitude (supply current can change from parts of microampere to tens of milliampere). The bandwidth must be wide enough due to the fact that a large current is consumed in pulses with a very short time. Similar situation exists in case of the energy supplied from alternative sources: energy is available at the output in unpredictable pulses of varying intensity of current and different voltages.

According to the definition, the consumed (or produced) energy can be determined as (1):

$$(1) \quad E = \int_{t_b}^{t_e} u_s(t) i_s(t) dt$$

where: $u_s(t)$, $i_s(t)$ – temporary values of supply voltage and current, respectively in t moment of time, t_b , t_e – beginning and end time of desired period of time the energy is calculated.

Authors of [8] have proposed to use the above definition directly according to the block diagram presented in Fig. 2. The method assumes sampling the supply voltage (ADC2) and current (ADC1) signals and performing multiplication and integration numerically by processing unit.

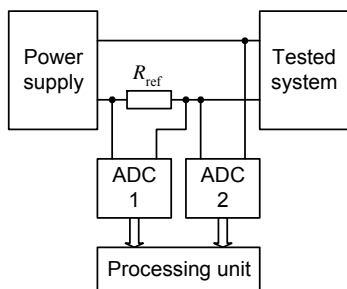

Fig. 2. The idea of energy measurement based on signals sampling and numerical integration

Despite its simplicity, the method has a number of drawbacks. First of all, the aforementioned need of high dynamics of the measured currents sets a requirement of high resolution and accuracy of the ADC1 to properly cover low supply currents while assuring possibility of high supply currents measurement. Unfortunately, on the other hand, the ADC sampling frequency must be high enough to catch all short pulses of high value supply current. It is difficult to find out AD converters which are both fast and have high resolution. Additionally, a fast processing unit is also required to serve computational efforts. A numerical integration errors should be also taken into an account.

For the presented reasons, Authors of [10] have proposed different approach, based on an assumption, that during the integration period, the supply voltage can be treated as constant (usually it is in fact stabilized) and equal to V_{cc} . Using this assumption, (1) can be written:

$$(2) \quad E = V_{cc} \int_{t_b}^{t_e} i_s(t) dt$$

The integral in (3) represents the charge consumed by the low-power circuit (or produced by the EH source).

Charge counting method gives more reliable results than the voltage and current measurement and hardware implementation is cheaper. Integration takes place in analog in the same measuring system. Measurement of charge can be carried out liberally long directly obtaining

the current average for the period. Using the charge meter we can also conduct indirect measurement of energy, avoiding the errors of numerical calculations and only using the properties of the system and passive components.

The implementation of a charge measuring method using current mirrors presented in [10] have some drawbacks, too. Unfortunately, the circuit as presented in the paper is not able to measure the amount of energy generated by the EH source, because the measured current is flowing out of the system (delivered to the load). Another problem is related to the voltage drop (ca. 2V) caused by the current mirror.

The Authors, in the paper [11] have proposed a simple elimination method of the above mentioned disadvantages by using an additional voltage follower and a current source providing an initial polarization. The proposed modification reduces voltage drop to few mV and allows to measure bi-directional current.

Despite high dynamics (almost 10000:1) measuring system based on current mirrors is cumbersome in practical application: in its original form according to a significant voltage drop, after the addition of a voltage follower due to appearing oscillations and the decrease of linearity. Shown circuit could be well in dedicated solution, but unfortunately not suitable for building an universal meter. It would also be troublesome changing the measuring range.

Charge balancing method use for micro energy measurement

The idea of the use of charge balancing method is presented in block diagram shown in Fig. 3.

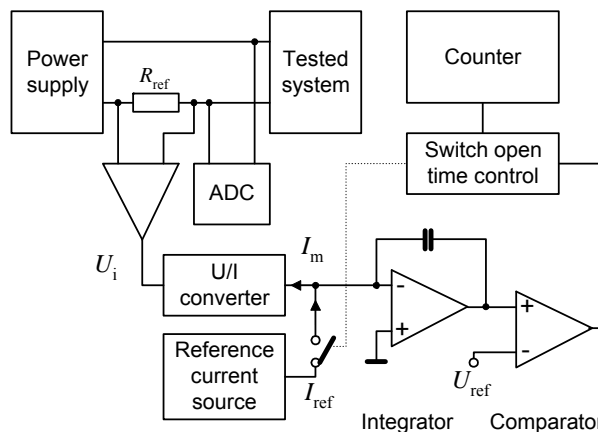

Fig. 3. Block diagram of the method for energy measurement using charge balancing

The proposed method uses different approach for both channels. The voltage is measured as previously using AD converter. It was assumed that the voltage changes are relatively small, so in a measurement period the voltage can be treated as constant and can be measured relatively seldom. In the current measurement channel, the most important is an integrator using OPAMP. The integrator integrates the current I_m obtained at the output of the voltage-to-current converter. The input of I/U converter is connected to the output of the differential amplifier measuring the voltage drop at the reference resistor R_{ref} . This way the current I_m is proportional to the supply current of the tested low-power system. While current I_m charges the integrator's capacitor, the integrator output voltage increases. The charging takes place until the output voltage reaches U_{ref} level. This moment is detected by comparator, which causes closing the switch. The reference current I_{ref}

is discharging the integrator for specified (programmed) time thus removing from the integrator precisely define charge portion. At the same time the counter value is

incremented. Using this balancing principle, the higher is the I_m current, the more frequently the integrator needs to be emptied.

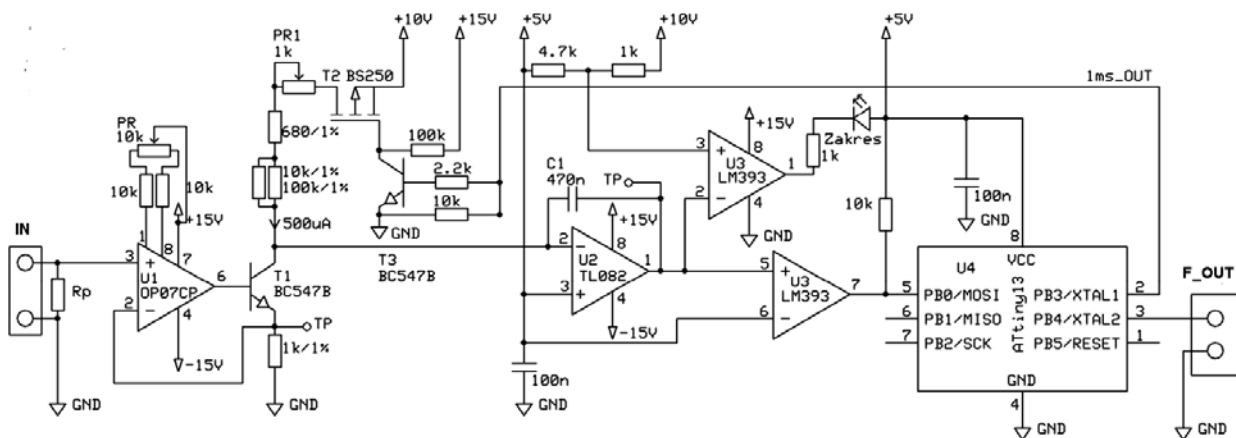

Fig. 4. Schematic diagram of the circuit implementing the modified charge counting method

Prototype implementation of charge balancing method testing

The presented idea was tested in a simplified prototype which schematic diagram is presented in Fig. 4. The prototype components were selected through simulation tests and verified experimentally in order to minimize thermal drift (especially in the input circuit) and to obtain the best linearity. In the prototype, the differential input amplifier was omitted. At the input of the measuring circuit (IN), there is voltage-to-current converter using an operational amplifier OP07CP characterised by low input offset voltage (typically 60 μV). Transistor T2 with surrounding components creates the source of compensating current with the output current equal to 500 μA . Due to this reference current value, the average current flowing to T1 collector (and proportional to voltage drop through R_p – thus proportional to supply current) cannot exceed 500 μA . Otherwise, the voltage at the integrator output will be increasing and finally will cause saturation of the amplifier U2, nevertheless continuously switched compensation current.

The integrated circuit U3 contains 2 comparators. One of them is used to detect overrange situation described in the previous paragraph. The second comparator detects when to switch on the compensation current and gives this information (high state) to ATtiny13 microcontroller input PB0. In such a situation, the microcontroller turns on the reference current for 1 ms and generates the pulse on the output PB3 (F_OUT). After 1 ms, the state of the comparator is checked again. Using simple microcontroller to control measurement prototype allowed to make experiments with different switch-on times. Switching on the compensation source causes voltage slope change depending on the input current. Basically, the integrator is charged by the current difference between input current and the compensation one e.g. when the current difference is equal to 500 μA and exists for 1 ms, the integrator output will be changed by 1.06 V. Normally, the voltage at the integrator output can swing from ca. 3.94 V up to 9.12 V (limited by the overrange detection circuit). The prototype cannot work standalone, the frequency output (F_OUT) should be connected to the frequency meter or counter.

Figure 5 shows oscillograms of exemplary waveforms at the output of the integrator and the comparator.

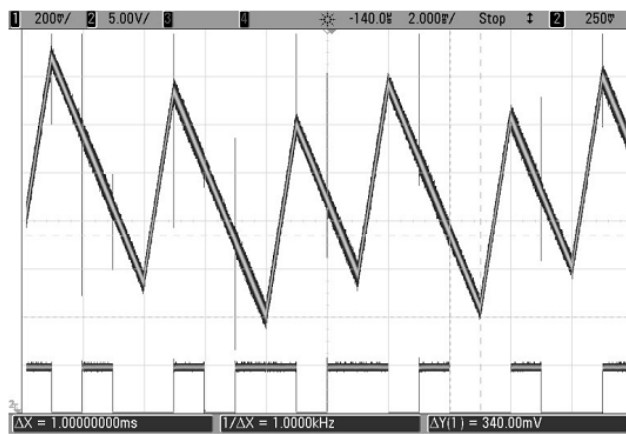

Fig. 5. Exemplary output signal of the integrator (upper) and comparator (lower)

The realised prototype was tested to check the linearity of the current to frequency conversion. The test results are presented in Fig. 6.

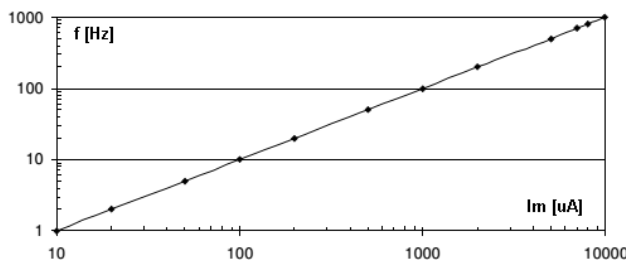

Fig. 6. Sensitivity characteristic of the prototype implementing the charge balancing method for energy measurement

When analysing the presented graph, it can be noted, that the single range prototype allowed linear measurement over 3 decades of input current change. To check the accuracy the relative errors were calculated and presented in Fig. 7.

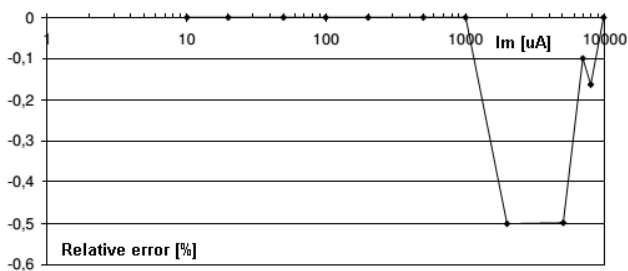

Fig. 7. Relative error of current to frequency conversion in the realized prototype

As one can see, the errors are below 0.5% in the range from 1 μA up to 10 mA (4 decades).

Conclusions

Modification, implementation and evaluation of energy measurement method based on charge balancing method for measurement of low-power energy systems were the main objectives of this work.

The results obtained during the tests of the prototype give fair promise of the wide application area of the presented method. Based on the idea used in some ADC architecture, wide measurement range and high linearity were obtained. After some modifications, the circuit will have the ability to measure sinking currents, produced by EH source as well as sourcing currents consumed by low-power circuits. Further works will provide range extension, lowering voltage drop on the current measuring resistor as well as combine counting circuit to create standalone instrument.

Authors: dr hab. inż. Grzegorz Lentka, Gdańsk University of Technology, Faculty of Electronics, Telecommunications and Informatics, Department of Metrology and Optoelectronics, ul. Narutowicza 11/12, 80-233 Gdańsk, E-mail: lentka@eti.pg.gda.pl; mgr inż. Dariusz Palmowski, Gdańsk University of Technology, Faculty of Electronics, Telecommunications and Informatics, Department of Metrology and Optoelectronics, ul. Narutowicza 11/12, 80-233 Gdańsk, E-mail: palmowski@eti.pg.gda.pl; mgr inż. Arkadiusz Hojka, Gdańsk University of Technology, Faculty of Electronics, Telecommunications and Informatics, Department of Metrology and Optoelectronics, ul. Narutowicza 11/12, 80-233 Gdańsk, E-mail: arkadiuszhojka@gmail.com

REFERENCES

- [1] Eskelinen J., Meyer K., Optimizing Microcontroller Power Efficiency for Ultra Low Power Designs, *Atmel White Paper*, 8223A –AVR –03/09.
- [2] Kompis C., Aliwell S., Energy Harvesting Technologies to Enable Remote and Wireless Sensing, Voderer Ltd and Zartech Ltd, 2008.
- [3] Vuellers R.J.M., Leonov V., Sterken T., Schmitz A., Energy Scavengers For Wireless Intelligent Microsystems, *OnBoard Technology* 06.2006.
- [4] Beeby S., White N., Energy Harvesting for Autonomous Systems, Artech House 2010.
- [5] Leonov V., Torfs T., Fiorini P., Van Hoof C., Thermoelectric Converters of Human Warmth for Self-Powered Wireless Sensor Nodes, *IEEE Sensors Journal*, 7 (2007), No. 5, 650-657.
- [6] Nasiri A., Zabalawi A.S., Goran M., Indoor Power Harvesting Using Photovoltaic Cells for Low Power Applications, *IEEE Transactions on Industrial Electronics*, 56 (2009), No.11, 4502-4509.
- [7] Dalola S., Ferrari M., Ferrari V., Guizzetti M., Marioli D., Taroni A., Characterization of Thermoelectric Modules for Powering Autonomous Sensors, *IEEE Transactions on Instrumentation and Measurement*, 58 (2009), No.1, 99-107.
- [8] Jiang X., Dutta P., Culler D., Stoica I., Micro Power Meter for Energy Monitoring of Wireless Sensor Networks at Scale, *IPSN'07*, April 25-27, 2007, Cambridge, Massachusetts, USA.
- [9] Bucci G., Fiorucci E., Ciancetta F., Luiso M., Measuring System for Microelectric Power, *IEEE Transactions on Instrumentation and Measurement*, 63 (2014), No. 2, 410-421.
- [10] Konstantakos, V., Kosmatopoulos, K., Nikolaidis S., Laopoulos T., Measurement of Power Consumption in Digital Systems, *IEEE Transactions on Instrumentation and Measurement*, 55 (2006) No.5, 1662 - 1670.
- [11] Lentka G., Palmowski D., Hojka A., Energy consumption estimation of low-power devices using an integrating coulombmeter, *Przeгляд Elektrotechniczny*, 92 (2016), No 12, 209-212.