



The author of the PhD dissertation: Przemysław Falkowski-Gilski
Scientific discipline: Telecommunications

DOCTORAL DISSERTATION

Title of PhD dissertation: Study Analysis of Transmission Efficiency in DAB+ Broadcasting System

Title of PhD dissertation (in Polish): Badanie i analiza efektywności transmisji w radiofonii cyfrowej DAB+

Supervisor	Second supervisor
<i>signature</i>	<i>signature</i>
Jacek Stefański, Ph.D., D.Sc.	<Title, degree, first name and surname>
Auxiliary supervisor	Cosupervisor
<i>signature</i>	<i>signature</i>
Sławomir Gajewski, Ph.D.	<Title, degree, first name and surname>



*To my beloved family, for their continuous support,
encouragement and priceless advice.*



Table of Contents

TABLE OF CONTENTS	5
LIST OF SYMBOLS	7
LIST OF ABBREVIATIONS	11
CHAPTER 1: INTRODUCTION	17
1.1. GOALS AND MOTIVATION	17
1.2. AIM AND THESIS OF THE DISSERTATION	19
1.3. MAIN PARTS OF THE DISSERTATION	19
CHAPTER 2: DAB+ DIGITAL RADIO	21
2.1. PHYSICAL CHANNEL	21
2.2. TRANSMISSION SYSTEM.....	23
2.2.1. MULTICARRIER MULTIPLEXING.....	23
2.2.2. FRAME STRUCTURE	26
2.2.3. CHANNEL CODING	27
2.3. RADIO BROADCASTING.....	29
2.3.1. TERRESTRIAL TRANSMISSION	29
2.3.2. CONTENT, SERVICE AND ENSEMBLE MANAGEMENT	30
2.3.3. SPECTRUM MANAGEMENT.....	31
2.3.4. ADDITIONAL DATA SERVICES.....	32
2.4. QUALITY ASPECTS	32
2.4.1. AUDIO CODING	33
2.4.2. QUALITY OF SERVICE AND QUALITY OF EXPERIENCE.....	36
2.4.3. QUALITY IN DIGITAL BROADCASTING	37
2.4.4. SUBJECTIVE AND OBJECTIVE QUALITY METRICS.....	38
CHAPTER 3: RESOURCE ALLOCATION IN DAB+	43
3.1. DAB+ MULTIPLEX	43
3.1.1. LOGICAL STRUCTURE	44
3.1.2. CURRENT ENSEMBLE CONFIGURATION.....	45
3.1.3. BITRATE ASSIGNMENT.....	47
3.2. QUALITY ASSESSMENT STUDY	48
3.2.1. REAL-TIME DAB+ BROADCASTED RADIO PROGRAMS.....	49

3.2.2. SIMULCASTED DAB+ AND FM RADIO PROGRAMS	50
3.2.3. NEW RADIO PROGRAMS	50
3.2.4. SIGNAL SAMPLES PROCESSED WITH THE AAC CODEC	51
3.2.5. SWITCHOVER FROM ANALOG TO DIGITAL RADIO DOMAIN.....	56
3.3. DISCUSSION	57
CHAPTER 4: SMOC ADAPTIVE MULTIPLEXING METHOD	59
4.1. THE SMOC METHOD.....	59
4.1.1. TRANSMITTED AUDIO SIGNALS AND CONTENT ANALYSIS	62
4.1.2. THE PCP METRIC	69
4.2. ADAPTIVE SMOC MULTIPLEXING SIMULATOR	71
4.2.1. TEST SCENARIO	72
4.2.2. MULTIPLEX RESOURCE MANAGEMENT	74
4.2.3. THE MCF METRIC	80
4.2.4. INTRODUCING ADDITIONAL AUDIO OR DATA SERVICES.....	83
4.3. DISCUSSION	87
CHAPTER 5: SMOC TECHNOLOGICAL DEMONSTRATOR	89
5.1. RADIO LINK	89
5.1.1. TRANSMITTING SIDE.....	91
5.1.2. RECEIVING SIDE	94
5.2. TEST SCENARIO	97
5.2.1. MULTIPLEX CONFIGURATION	98
5.2.2. ENSEMBLE CONFIGURATION.....	99
5.3. RESULTS	101
5.3.1. RECEPTION	101
5.3.2. SUBJECTIVE QUALITY ASSESSMENT	103
5.4. DISCUSSION	105
CHAPTER 6: SUMMARY – MAIN ACHIEVEMENTS OF THE DISSERTATION.....	109
LITERATURE	113
LIST OF FIGURES	123
LIST OF TABLES	125

List of Symbols

<i>Symbol</i>	<i>Description</i>
α	Probability of making an error
β	Angle of the incoming signal
γ_n	Combination of TF decomposition parameters
Δ	OFDM guard interval
ϕ_n	Phase of the exponential function
λ	Wavelength
a_n	Expansion coefficient
A_i	Number of audio services
b	Set of coefficients
c	Velocity of light
C	Share of commercial content
d	Constant
D_j	Numer of data services
f_0	Transmission frequency
f_D	Doppler frequency shift
f_{Dmax}	Maximum Doppler frequency shift
f_n	Frequency of the exponential function
f_v	Feature vector
F	F-ratio test statistic used in ANOVA
F_{crit}	Critical (cutoff) value
F_{FIB_i}	FIB frame i
FIB_{Count}	Number of received FIB frames

$FIB_{ErrorRate}$	FIB error rate
$g_{\gamma_n}(t)$	TF function
$G(f)$	Jakes power spectrum density function
L	Length of analyzed period
M_C	Share of classicist music content
M_E	Share of electronic music content
M_P	Share of popular music content
N_E	Number of received erroneous FIB frames
N_S	Number of services
N_T	Number of received FIB frames
O	Share of other content
p_A	Probability of introducing additional services
p_n	Temporal placement
p_r	Set of priorities
P	Probability value (significance of a test)
q	Numer of features
R	Set of functions
$R(f)$	Doppler spectrum
R_{A_i}	Resources allocated per audio service A_i
$R_{Allocated}$	Allocated ensemble resources
R_{Audio}	Ensemble resources allocated among audio services
R'_{Audio}	Ensemble resources allocated among audio services using the SMOC method
R_{D_j}	Resources allocated per data service D_j
R_{Data}	Ensemble resources allocated among data services

R_E	Ensemble resources
R_{Fixed}	Resources required for fixed bitrate assignment
R_{Free}	Free ensemble resources
R_{P_t}	Probability of saving enough resources in period t
R_Q	Set of required resources
R_{S_t}	Resources saved in period t
R_{Saved}	Averaged saved resources using the SMOC method
R_{SMOC}	Resources required for adaptive SMOC bitrate assignment
s_n	Scale factor
$s(t)$	OFDM signal
S	Share of speech content
T	Time interval (Fourier period)
T_S	Time of a symbol
u	Set of features
v	Speed of the vehicle
x_A	Weight for speech content
x_B	Weight for classicist music content
x_C	Weight for popular music content
x_D	Weight for electronic music content
x_E	Weight for other content
x_F	Weight for commercial content
$x(t)$	Analyzed signal
z_k	Complex Fourier coefficient



List of Abbreviations

<i>Abbreviation</i>	<i>Explanation</i>
AAC	Advanced Audio Coding
AAC-LC	Advanced Audio Coding Low Complexity
ACI	Adjacent Channel Interference
ACR	Absolute Category Rating
ADC	Analog-to-Digital Converter
ANIQUE	Auditory Non-Intrusive Quality Estimation
ANIQUE+	Auditory Non-Intrusive Quality Estimation plus
ANOVA	Analysis of Variance
AoA	Angle-of-Arrival
API	Application Programming Interface
ATFT	Adaptive Time-Frequency Transform
BER	Bit Error Rate
CCR	Comparative Category Rating
CD	Compact Disc
CDF	Cumulative Distribution Function
CIF	Common Interleaved Frame
COFDM	Coded Orthogonal Frequency Division Multiplexing
CP	Content Provider
CRC	Cyclic Redundancy Code
CS	Content Signal
CS'	Modified Content Signal
CU	Capacity Unit
DAB	Digital Audio Broadcasting

DAB+	Digital Audio Broadcasting plus
DAC	Digital-to-Analog Converter
DIQ	Digital In-phase and Quadrature
DLS	Dynamic Label Segment
DMB	Digital Multimedia Broadcasting
DPS	Doppler Power Spectrum
DQPSK	Differential Quadrature Phase Shift Keying
DRM	Digital Radio Mondiale
DRM+	Digital Radio Mondiale plus
DVB	Digital Video Broadcasting
DVB-T	Digital Video Broadcasting – Terrestrial
EBU	European Broadcast Union
EEP	Equal Error Protection
EPG	Electronic Programme Guide
ETI	Ensemble Transport Interface
FFT	Fast Fourier Transform
FIB	Fast Information Block
FIC	Fast Information Channel
FIG	Fast Information Group
FM	Frequency Modulation
FPGA	Field-Programmable Gate Array
GI	Guard Interval
GPIO	General-Purpose Input/Output
GUI	Graphical User Interface
HE-AAC	High Efficiency Advanced Audio Coding



I/Q	In-phase and Quadrature
IFFT	Inverse Fast Fourier Transform
IS	Information Signal
IS'	Modified Information Signal
ITU	International Telecommunication Union
JCR	Journal Citation Reports
JTAG	Joint Test Action Group
KBD	Kaiser-Bessel Derived
LCD	Liquid Crystal Display
LDA	Linear Discriminant Analysis
LPF	Low-Pass Filter
M/S	Mid/Side
MCF	Multiplex Content Factor
MCI	Multiplex Configuration Information
MDCT	Modified Discrete Cosine Transform
MFN	Multiple Frequency Network
MOS	Mean Opinion Score
MPEG	Moving Picture Experts Group
MS	Multiplex Stream
MSC	Main Service Channel
MUSHRA	Multiple Stimulus with Hidden Reference and Anchor
NBC	National Broadcasting Council
NPO	Non-Profit Organization
ODG	Objective Difference Grade
OEC	Office of Electronic Communications



OFDM	Orthogonal Frequency Division Multiplexing
PAD	Program Associated Data
PC	Personal Computer
PCP	Program Content Profile
PEAQ	Perceptual Evaluation of Audio Quality
PESQ	Perceptual Evaluation of Speech Quality
POLQA	Perceptual Objective Listening Quality Assessment
PPM	Parts-Per-Million
PPS	Pulse-Per-Second
PRS	Phase Reference Symbol
PS	Parametric Stereo
PSD	Power Spectrum Density
PSQM	Perceptual Speech Quality Measure
QoE	Quality of Experience
QoS	Quality of Service
QPSK	Quadrature Phase Shift Keying
RCPC	Rate-Compatible Punctured Convolutional
RDI	Receiver Data Interface
RDS	Radio Data System
RF	Radio Frequency
RFIC	Radio Frequency Integrated Circuit
RS	Reed-Solomon
RSI	Result Signal
RX	Receiver
SBR	Spectral Band Replication



SCS	Summary Content Stream
SDG	Subjective Difference Grade
SDR	Software-Defined Radio
SFN	Single Frequency Network
SLS	Slideshow
SMA	Subminiature version A
SMOC	Speech, Music, Other, Commercial
SMS	Short Message Service
SNR	Signal-to-Noise Ratio
T-DMB	Terrestrial Digital Multimedia Broadcasting
TCXO	Temperature Compensated Crystal Oscillator
TM	Transmission Mode
TNS	Temporal Noise Shaping
TPEG	Transport Protocol Experts Group
TX	Transmitter
UEP	Unequal Error Protection
UHD	USRP Hardware Driver
UPnP	Universal Plug-and-Play
USB	Universal Serial Bus
USRP	Universal Software Radio Peripheral
UX	User Experience
ViSQOL	Visual Speech Quality Objective Listener
VoIP	Voice over IP





Chapter 1: Introduction

With over two billion receivers operating worldwide, radio transmission is by far the most accessible medium. It has been a part of our lives since the 1920's and has become one of the most trusted and friendly mass media. Today, its popularity is still strong, despite the outcome of many electronic media. In order to transform the radio into a viable medium of the 21st century, it will have to migrate from analog to digital technology domain. It will have to adopt to new means and ways of delivering content, as well as new transport and distribution mechanisms, including terrestrial, satellite and cable communications.

One of the first digital terrestrial broadcasting technology, successfully developed and marked, is the DAB (*Digital Audio Broadcasting*) system. Actively supported by the EBU (*European Broadcast Union*) and widely promoted by the WorldDAB forum. With an increasing range of receiver terminals that are becoming more affordable, the DAB system, along with its successor, DAB+ (*Digital Audio Broadcasting plus*), has been adopted for terrestrial broadcasting as a replacement for analog FM (*Frequency Modulation*) technology.

DAB+ is a very innovative and universal multimedia broadcasting system. Currently, broadcasting organizations, manufacturers and network providers are implementing digital broadcast services in several countries worldwide. Thanks to its updated multimedia technologies and metadata options, digital radio keeps pace with changing consumer expectations and the impact of media convergence.

1.1. Goals and Motivation

According to the Regional Agreement on planning digital terrestrial broadcasting in Region 1 (Geneva 2006), Poland obtained the right to develop 3 multiplexes, that is a set of audio and data services, in Band III (174 – 240 MHz). The target multiplex ensemble will consist of 10 national and 2 regional broadcasts [125].

Based on this agreement, on February 24th 2012 the Polish OEC (*Office of Electronic Communications*) published a decision on frequency reservation. In October 2013, Polish Radio began its regular broadcasting in the DAB+ standard.

In its R 138 recommendation [101], EBU highlighted the benefits of implementing digital radio and pointed to DAB+ as the leading broadcasting standard. The choice of DAB+, in addition to a higher coverage, ensures high transmission quality of digital radio programs, as well as other additional services, including a list of programs, programmable recording and graphical information. A portion of the bandwidth may be also used to transmit traffic information or weather forecasts.

The process of managing content, services and forming the ensemble of the DAB+ broadcasting system, including assigning bitrates and allocating resources to particular radio programs, is standardized and described in [103][105]. The DAB+ transmission network can have national, regional or local coverage. Depending on geographical and financial requirements, it may operate in Band III or L-Band. The bandwidth required for a single multiplex ensemble is equal to 1.5 MHz.

As a result of international agreements, a fixed bitrate assignment method was established. However, considering the broad development of both national and regional broadcasters, as well as the scope of possible services and user demands, a fixed bitrate assignment method does not guarantee efficient multiplex resource management, especially under limited bandwidth conditions. The type of content transmitted over different programs does vary, depending on the profile of the radio program, as well as time of the day. It is worth mentioning that radio programs consist of different types of content, which is clearly visible in the schedule of particular broadcasters.

The above formed the basis of study and research in order to develop a new bitrate assignment and resource allocation method for the DAB+ broadcasting system, under limited multiplex resource conditions. For this reason, work was undertaken in order to develop efficient algorithms for allocating physical resources to increase the efficiency of this allocation for different radio programs. This allocation depends on various characteristics and quality requirements assigned to different radio programs, which depend on the type of provided services, in particular transmitting content in the form of audio and speech signals. This represents a major scientific problem of great practical importance.

Bearing this in mind, a technological demonstrator of the adaptive DAB+ multiplex has been prepared, in the Department of Radio Communication Systems and Networks. The efficiency of the proposed solution was tested in operating conditions using two radio receivers compatible with the DAB+ standard.

1.2. Aim and Thesis of the Dissertation

The aim of this dissertation is to develop a new adaptive bitrate assignment and resource allocation method for the DAB+ broadcasting system, in order to provide high quality services, as well as increase the efficiency of allocating physical resources for different radio programs in a single multiplex. In this case, the efficiency parameter is defined as the number of transmitted radio programs in a single 1.5 MHz frequency block, along with additional data services, that are available to consumers and regarded by them, in a subjective way, as of high quality.

The basis for achieving this goal was to prove the following thesis, namely, that: *A high transmission efficiency in the DAB+ digital broadcasting system may be achieved through an adaptive bitrate assignment method for radio programs, under limited physical resource conditions of this system.*

It is worth mentioning, that an adaptive method of allocating physical resources would increase the efficiency of this allocation under limited multiplex resource conditions, as well as provide high quality services and content to the user side.

1.3. Main Parts of the Dissertation

This dissertation includes 125 literature items, 12 of which are the author's work with 1 JCR (*Journal Citation Reports*) publication. It consists of 6 parts, namely an introduction to the subject matter, including the aim and thesis of the dissertation, which is contained in Chapter 1.

Description of the DAB+ digital broadcasting standard, including the physical channel, transmission system, content, service and ensemble management, as well as quality aspects related with terrestrial broadcasting, is contained in Chapter 2.

Resource allocation in DAB+, including both configuration and management of the ensemble, as well as a study concerning subjective and objective quality assessment, along with user expectations, is contained in Chapter 3.

Study on resource allocation in the DAB+ broadcasting system, including the current multiplex ensemble configuration of the national broadcaster, along with an analysis considering transmitted content, profile of a radio program, resource management and bitrate assignment, according to the described concept of the proposed solution, is contained in Chapter 4.

Description of the technological demonstrator of the adaptive DAB+ multiplex, including the designed radio link, with both transmitting and receiving side, the test scenario, along with multiplex and ensemble configurations, as well as a quality evaluation study of the designed solution, is contained in Chapter 5.

Summary of the dissertation, including main achievements and proven thesis, is contained in Chapter 6.

Chapter 2: DAB+ Digital Radio

The Eureka 147 DAB system has been developed in the 1980's by a European consortium composed of broadcasters, manufacturers, network providers and research institutes. Its main goal is to provide high-quality digital audio and data broadcasting services. It focuses not only on fixed reception, but also portable and mobile reception with simple whip antennas, as well as fast-moving objects such as cars. The system can operate in severe conditions, including dense urban areas [80]. The DAB system and its successor DAB+ are now considered as fully free, they can be manufactured and utilized by any interested third party as long as it fulfills the license conditions.

DAB+ has several advantages over conventional analog broadcasting services. The main benefit is that it can offer higher sound quality compared with analog transmission, indistinguishable from that of the CD (*Compact Disc*). Furthermore, compared with analog, digital broadcasting is less vulnerable to interference [59].

2.1. Physical Channel

Mobile reception without disturbance was one of the basic requirements for the DAB+ system. As a result of multipath propagation, the electromagnetic wave is scattered, diffracted, reflected and reaches the antenna in various ways as an incoherent superposition of many signals with different travel times. This leads to interference, which depend on the frequency and location, as well as time in case of a mobile receiver [52][93].

In case of a mobile receiver, the interference pattern changes within milliseconds and varies over the transmission bandwidth. One can say, that the mobile radio channel is characterized by time variance and frequency selectivity. The time variance itself is characterized by the speed of the vehicle v and the wavelength $\lambda = c / f_0$, where c is the velocity of light and f_0 is the transmission frequency. The relevant physical quantity is the maximum Doppler frequency shift, as defined in Form. (2.1):

$$f_{D \max} = \frac{v}{c} f_0. \quad (2.1)$$

The actual Doppler shift of a wave with angle β relative to the vector of speed of a vehicle is defined in Form. (2.2) as:

$$f_D = f_{D \max} \cos(\beta). \quad (2.2)$$

Typically, the received signal is a superposition of numerous scattered and reflected signals. That is why we may speak not of a Doppler shift, but of a Doppler spectrum. The most popular Doppler spectrum is the Jakes spectrum, that corresponds to the isotropic distribution of β [81]. It relates to a bathtub-like Doppler spectrum $R(f)$, described in Form. (2.3) as:

$$R(f) = \frac{1}{\pi} \frac{1}{\sqrt{f_D^2 - f^2}}, \quad (2.3)$$

where $|f| \leq |f_D|$. Although, this model applies for a specific scenario of omnidirectional scattering and a moving receiver, it has been utilized in other scenarios as well, mainly due to its simplicity.

The spectrum of the received signal depends on the assumptions made by the AoA (*Angle-of-Arrival*) statistics and the radiation pattern of the receiving antenna. Under the common assumption of a 2-D isotropic scattering environment with an omnidirectional receiving antenna with uniformly distributed phases over $(0, 2\pi)$, Gans introduced the notation of a DPS (*Doppler Power Spectrum*) [24]. Based on the flat-fading channel model developed by Clarke [15], the PSD (*Power Spectrum Density*) function $G(f)$ has a U-shaped form, bandlimited to $\pm f_D$. This is referred to as the Jakes PSD, as described in Form (2.4):

$$G(f) = \begin{cases} \frac{1}{2\pi f_D} \frac{1}{\sqrt{1 - (f/f_D)^2}} & \text{for } |f| < f_D \\ 0 & |f| \geq f_D \end{cases}. \quad (2.4)$$

As a signal is transmitted, a series of attenuated and delayed versions of the original signal is received, leading to a typical multipath channel response. Furthermore, this channel response changes over time, due to which two different time-varying propagation scenarios are possible. First, if the receiver or transmitter is mobile, it moves through the interference pattern generated by the electromagnetic waves and a different channel response is observed at each location. This time-variation has been studied extensively, modeled, and described by Jakes in [47]. Second, if the receiver and transmitter are stationary but reflectors in the indoor environment move, the interference pattern itself will change over time. This sort of time-variations is described in [88].

The superposition of Doppler-shifted carrier waves leads to a fluctuation of the carrier amplitude and phase. This means, that the received signal has been amplitude and phase modulated by the channel itself. In case of digital phase modulations, these rapid phase fluctuations cause severe problems if the carrier phase changes too much during the time T_S , required to transmit one digitally modulated symbol. Of course, both amplitude and phase

fluctuate randomly. The typical frequency of the variation is of the order of f_{Dmax} . Consequently, digital transmission with symbol time T_S is possible, as defined in Form. (2.5), if:

$$f_{Dmax}T_S \ll 1. \quad (2.5)$$

The frequency selectivity of the channel is determined by different travel times of the signals, which can be calculated as the ratio between the travelling distance and the velocity of light. Travel time differences of some microseconds are typical for cellular mobile radio. In case of a broadcasting system, covering a large area, echoes up to 100 μ s are possible in hilly or mountainous regions. In its SFN (*Single Frequency Network*) variant, the system must cope with even longer echoes. Longer echoes correspond to more fades inside the transmission bandwidth.

In the time domain, intersymbol interference disturbs the transmission if the travel time differences are not much smaller than the symbol duration T_S . As an example, a data rate of 200 kbps leads to $T_S = 10 \mu$ s for the QPSK (*Quadrature Phase-Shift Keying*) modulation. This is of the same order as the echoes. This indicates, that digital transmission of that data rate is not possible without using more sophisticated methods. These methods include equalizers, spread spectrum and multicarrier techniques. In case of the DAB+ system, it was decided to use multicarrier multiplexing, because it is able to cope with very long echoes and easy to implement.

2.2. Transmission System

The DAB+ transmission system utilizes several advanced techniques, such as OFDM (*Orthogonal Frequency Division Multiplexing*), RCPC (*Rate-Compatible Punctured Convolutional*) and RS (*Reed-Solomon*) codes, as well as time-frequency interleaving [56][57][87]. The aspect of resource management in OFDM-based networks is still a widely discussed topic [22][23].

2.2.1. Multicarrier Multiplexing

In order to cope with the problem of intersymbol interference caused by long echoes, DAB+ utilizes the multicarrier technique known as OFDM. The idea behind multicarrier multiplexing is to split up the high-rate data stream into K parallel data streams of low data rate and to modulate each of them separately on its own sub-carrier. This leads to an increase of the symbol duration T_S by a factor of K . For sufficiently high K , it is possible to keep T_S significantly longer than the echo duration and to make the system less sensitive to intersymbol interference.

OFDM is a spectrally efficient technique, because it minimizes the frequency separation between individual carriers by allowing some controlled spectral overlap between the carriers, without causing ACI (*Adjacent Channel Interference*). The OFDM signal $s(t)$ is a kind of signal synthesis by a finite Fourier series, defined in Form. (2.6) as:

$$s(t) = \sum_{k=-K/2}^{K/2} z_k \cdot e^{j2\pi kt/T}, \quad (2.6)$$

where T is the time interval (Fourier period), z_k is the complex Fourier coefficient carrying the digitally coded information.

For each time interval of length T , another set of $K + 1$ information carrying coefficients can be transmitted. The Fourier synthesis can be interpreted as multiplexing of each complex modulation symbol z_k on a complex carrier wave $\exp(j2\pi kt/T)$ with frequency k/T ($k = \pm 1, \pm 2, \dots, \pm K/2$). The signal $s(t)$ is the complex baseband signal and has to be converted to a RF (*Radio Frequency*) signal by means of a quadrature modulator. At the receiving side, Fourier analysis of the downconverted complex baseband signal will produce the complex symbols according to Form. (2.7):

$$z_k = \frac{1}{T} \int_0^T e^{-j2\pi kt/T} s(t) dt, \quad (2.7)$$

which results from the orthogonality of the carried waves. The Fourier analysis and synthesis is implemented digitally using the FFT (*Fast Fourier Transform*) and IFFT (*Inverse Fast Fourier Transform*) algorithms. The transmission chain is shown in Fig. 2.1. The part of the OFDM signal that transmits the K complex coefficients z_k is called the OFDM symbol.

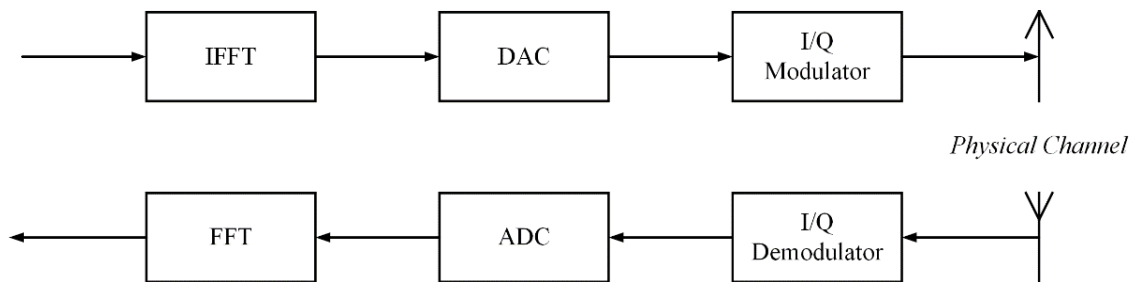

Fig. 2.1. FFT implementation of OFDM.

In order to make the transmission more robust against long echoes, the OFDM symbol period T_s will be made longer than the Fourier period T by the so-called cyclic prefix or guard interval of length Δ , simply by cyclic continuation of the signal. A synchronization error smaller than Δ will only lead to a frequency-dependent but constant phase shift. Echoes, as a superposition of ill-synchronized signals, will cause no intersymbol interference, as long as the

delays are smaller than Δ . In case of DAB+, DQPSK (*Differential Quadrature Phase Shift Keying*) is used, so that this constant phase is canceled out at the demodulator.

On the other hand, long echoes require a long guard interval and a long T_S . In order to keep the system efficient in different situations, four TMs (*Transmission Modes*) have been defined, as described in Tab. 2.1.

Tab. 2.1. DAB+ transmission modes [43].

	<i>Transmission Mode</i>			
	<i>I</i>	<i>II</i>	<i>III</i>	<i>IV</i>
<i>General</i>				
Bandwidth	1.536 MHz			
Data rate	2.4 Mbps			
Maximum frequency	375 MHz	1.5 GHz	3 GHz	750 MHz
Maximum transmitter separation	96 km	24 km	12 km	48 km
Frame duration	96 ms	24 ms	24 ms	48 ms
Elementary period	488.3 ns (1/2048000 s)			
<i>Number of samples</i>				
NULL symbol length	2656	664	345	1328
Guard Interval length	504	126	63	252
Guard Interval duration	246 μ s	62 μ s	31 μ s	123 μ s
FFT length	2048	512	256	1024
OFDM symbol length (GI + FFT)	2552	638	319	1276
OFDM symbol duration	1246 μ s	312 μ s	156 μ s	623 μ s
Number of sub-carriers	1536	384	192	768
Carrier spacing	1 kHz	4 kHz	8 kHz	2 kHz
<i>Logical structures (per frame)</i>				
Number of OFDM symbols per frame	76	76	153	76
Number of OFDM symbols per FIC	3	3	8	3
Number of FIBs per FIC	12	3	4	6
Number of CIFs	4	1	1	2
Number of FIB per CIF	3	3	4	3
<i>Bit length (constant)</i>				
Capacity Unit	64 bits			
FIB length	256 bits (4*CU)			
CIF length	55296 bits (864*CU)			



Each TM defines a number of parameters related to e.g. frame structure, subunits quantity and length. The choice of a mode depends on system requirements, the type of transmission, i.e. terrestrial, satellite or hybrid, and carrier frequency. There are 4 transmission modes, including [103]:

1. Mode I – designed for terrestrial transmission in Band I (47 – 88 MHz), Band II (87.5 – 108 MHz) and Band III (174 – 240 MHz).
2. Mode II – utilized in terrestrial, satellite and hybrid transmission in L-Band (1452 – 1492 MHz).
3. Mode III – intended for terrestrial, satellite and hybrid transmission below 3 GHz.
4. Mode IV – applied similarly as Mode II.

After inserting additional correction mechanisms, the effective bitrate that can be divided among services of the DAB+ stream is equal to 1152 kbps. Of course, the bitrate assigned to a particular service has a significant impact on the end user perceived quality.

The product of the number of sub-carriers K and the spacing $1/T$ between them is the same for all transmission modes. The total signal bandwidth for all TM is equal to approx. 1.5 MHz. The ratio Δ/T stays also the same. Additional information on broadband satellite systems and satellite broadcasting may be found in [2][60].

2.2.2. Frame Structure

Each transmission mode has a frame defined on the physical signal level as a periodically repeating structure of OFDM symbols that fulfill certain tasks for the data stream. The structure of the DAB+ frame consists of 3 elements, as shown in Fig. 2.2, namely:

1. SYNCH (*Synchronization*) – responsible for synchronizing the transmitter and receiver, as well as frequency and gain adjustments.
2. FIC (*Fast Information Channel*) – transmits information about the configuration of the multiplex, including the number of services and assigned bitrate.
3. MSC (*Main Service Channel*) – contains the actual audio data.

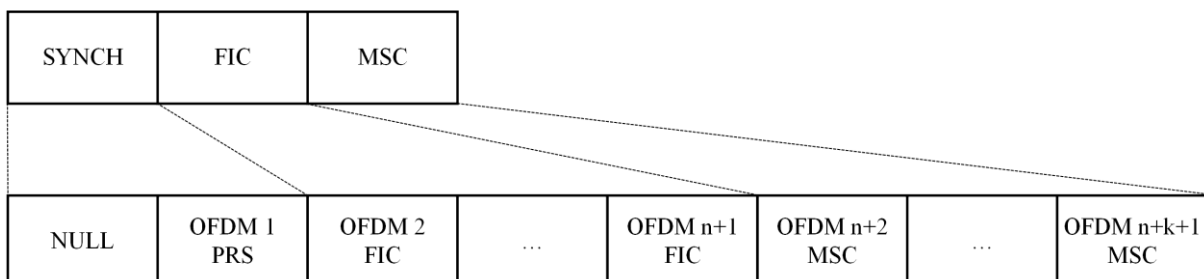

Fig. 2.2. DAB+ frame structure.

The *NULL symbol* is used to determine the beginning of the DAB+ frame. If two successive symbols are known, the transmission mode can be easily determined by the receiver. The PRS (*Phase Reference Symbol*) is the second OFDM symbol in the synchronization part. The receiver can also employ the PRS for more precise frame synchronization and frequency offset correction, which is realized by cross-correlation in time between the received and theoretical PRS.

The FIC contains information on how the multiplex is organized. Every receiver must process this data in order to present a list of available DAB+ services. The FIC consists of multiple FIBs (*Fast Information Blocks*), where each FIB contains 30 bytes of data and 16 bits of CRC (*Cyclic Redundancy Code*). Additional material concerning CRC algorithms can be found in [12][77]. Each FIB consists of multiple FIGs (*Fast Information Groups*), which contain information about available services, their names and configuration.

The MSC is a time-interleaved data channel divided into a number of sub-channels, individually convolutionally coded, with EEP (*Equal Error Protection*) or UEP (*Unequal Error Protection*) error protection. There are 8 EEP protection levels available. For the so-called A-profiles: 1-A, 2-A, 3-A, 4-A, data rates need to be integer multiples of 8 kbps. Whereas, for B-profiles, the data rate has to be a multiple of 32 kbps.

Each sub-channel may carry one or more service components, i.e. audio or data, where data components are referred to as PAD (*Program Associated Data*). The PAD may be extended to the so-called X-PAD (*Extended Program Associated Data*). In this case, the PAD group size increases and the audio sub-band sample group decreases.

For all 4 transmission modes, the MSC transports 864 CUs (*Capacity Units*). The CUs are addressed 0 to 863, each of which contains 64 bits. Each CU may only be used for one sub-channel. The data frame of 864 CUs, equal to 55296 bits, common for all transmission modes, is called CIF (*Common Interleaved Frame*). Additional information can be found in [108].

2.2.3. Channel Coding

The DAB+ system offers a variety of error protection techniques for different applications and different physical transmission channels. Thanks to the RCPC coding, it is possible to use codes of different redundancy without the necessity for different decoders [37]. RCPC codes offer the possibility of introducing UEP of a data stream, which means that some bits may require a very low BER (*Bit Error Rate*), whereas others may be less sensitive against errors. This approach enables to save capacity and add as much redundancy as necessary.

RS codes may be regarded as the most important block codes, due to their high relevance for many practical applications, including space communication, digital storage media, and of course broadcasting systems.

In DAB+, channel coding is based on a frame structure of 24 ms, where these frames are referred to as logical frames. They are synchronized with the transmission frames and (for audio) with the audio frames. First, at the beginning of one logical frame, the coding starts with the shift registers in the all-zero state. At the end, the shift register will be forced back to the all-zero state by appending 6 additional bits, so-called tail bits, to the useful data to help the Viterbi decoder. After encoding this 24 ms logical frame builds up a punctured codeword. It always contains an integer multiple of 64 bits, that is an integer number of CUs. A data stream of subsequent logical frames, that is coded independently of other data streams, is called a sub-channel, i.e. an audio data stream of 64 kbps represents one sub-channel, whereas a PAD data stream is always a part of a particular audio sub-channel [44].

After channel encoding, each sub-channel is time interleaved independently, and later all sub-channels are multiplexed together into the CIF frame. The convolutional code itself does not guarantee a sufficient low residual BER. Therefore, additional Reed-Solomon coding is necessary to remove these residual errors. The block diagram of the DAB+ concatenated coding system is shown in Fig. 2.3.

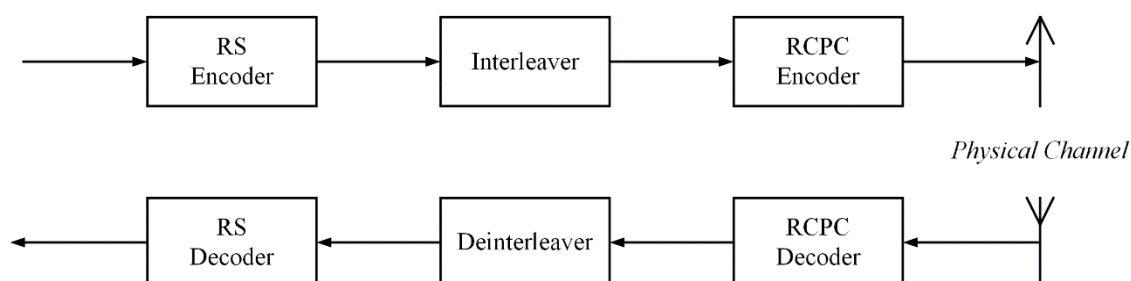

Fig. 2.3. DAB+ concatenated coding system.

Reed-Solomon codes may be regarded as the most important block codes, due to their relevance and availability in many practical applications, including communications, digital storage media, and of course digital broadcasting systems. The most common RS codes are based on byte arithmetics, rather than bit arithmetics. As a result, they correct byte errors instead of bit errors. Therefore, RS codes are favorable for channels with bursts of bit errors, as produced by the Viterbi decoder in the DAB+ system. They lead to a very low output residual error rate if the input error rate is moderate. Thus, an inner convolutional code concatenated with an outer RS code is a suitable setup if a very low residual error rate is needed in case of a mobile radio transmission.



RS codes based on byte arithmetics have the code word length of $N = 2^8 - 1 = 255$. For an RS(N, K, t) code, K data bytes are encoded to a code word of N bytes and the code can correct up to t byte errors. In practice, the fixed code word of length $N = 255$ is an undesirable restriction. The DAB+ broadcast system utilizes a shortened RS(120, 110, $t = 5$) code, that is obtained from the original RS(255, 245, $t = 5$) code. It may happen, that the decoder detects errors which cannot be corrected. In that case, an error flag is set to indicate that a portion of data is in error. Further information may be found in [6].

2.3. Radio Broadcasting

Radio broadcasting, thanks to its widespread and availability, connects people from diverse backgrounds and provides them with information that otherwise might be unavailable. It delivers the only free-to-air and cost-effective method for a truly mobile reception. However, in all developed markets, conventional analog and digital radio transmission is constrained by the lack of available spectrum. According to the EBU [120] radio is:

1. Of vital cultural importance throughout Europe.
2. Consumed by a vast majority of Europeans every week.
3. Consumed at home, at work and on the move.

That is why the main objective of today's international broadcasters is to design and implement novel services based on the most up-to-date delivery systems.

2.3.1. Terrestrial Transmission

Traditionally, the concept of broadcasting is based on MFNs (*Multiple Frequency Networks*). In the MFN, adjacent transmitters radiate the same program. However, they operate on different frequencies in order to avoid interference where the coverage areas of different transmitters overlap. In contrast to FM, DAB+ allows SFNs, where all operating transmitters of the network transmit exactly the same information on the same frequency. All transmitters are synchronized to each other in frequency and fulfil certain time delay requirements. This enables complete coverage of a very large region without the receiver having to tune to a different frequency while moving around in this area.

Broadcasting analog and digital radio services does vary, concerning devices on both transmitting and receiving side, as well as content processing mechanisms. However, the biggest difference is the way of managing content from numerous service providers. The difference between signal forming in analog FM and digital DAB+ terrestrial radio transmission is described in Fig. 2.4.

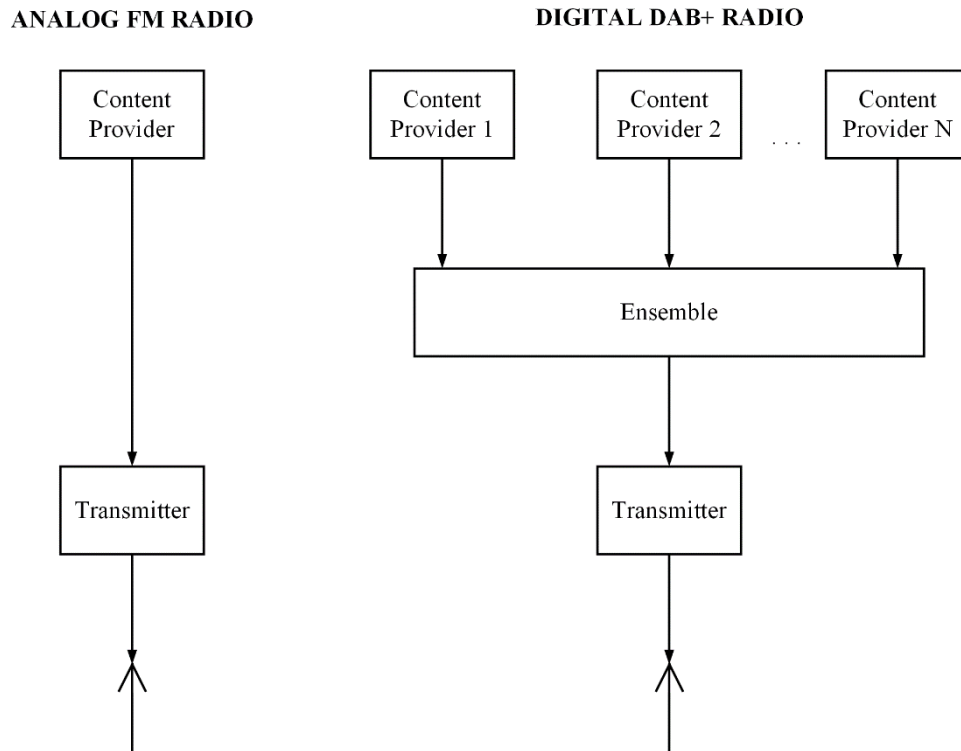

Fig. 2.4. Difference between analog FM and digital DAB+ radio transmission.

The main difference between forming the analog and digital radio signal is the fact, that in case of digital DAB+ transmission signals from all service providers need to be grouped in the so-called ensemble before entering the transmitter. Of course, the number of content providers, as well as assigned bitrate, is limited by the regulator.

2.3.2. Content, Service and Ensemble Management

In case of traditional analog FM radio, the program provider, that is an editor or supervisor, was responsible for the whole process of production of the audio content and forming the studio output into the broadcast chain for distribution and transmission purposes. No further changes in either content or quality were present. In case of DAB+, the complex structure of content, including different audio and data services with different quality level, program associated data, etc., requires a more diverse responsibility for managing this content. The structure of the DAB+ management link is described in Fig. 2.5.

When it comes to content management, audio and data content providers may deliver dependent or independent services, related with the number and type of contracted services. The audio coding process itself may be carried out either by the content or service management side.

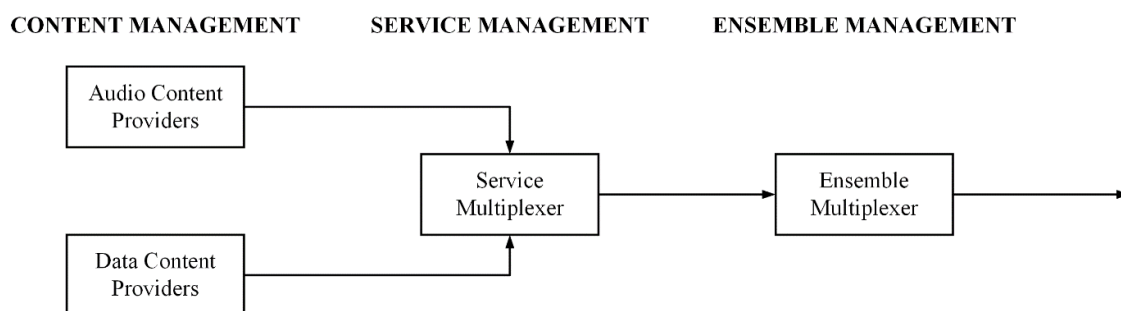

Fig. 2.5. DAB+ management link.

The program output from audio and data content providers is then passed to the service multiplexer, which manages the multiplex. It handles reconfiguration requests, including audio and data parameters such as bitrate, mono or stereo mode, etc. Finally, all data processed by the service management side are multiplexed by the ensemble multiplexer and fed to the transmitter.

2.3.3. Spectrum Management

The next advantage is that DAB+ is more spectrum efficient, which means that it is possible to increase the number of available radio programs. A single FM radio program occupies a block of 250 kHz, whereas in DAB+ about 12-15 radio programs can be placed in one 1.5 MHz block. This means that digital DAB+ radio is at least two times more efficient than analog FM radio. With the advance in audio coding techniques, it will be possible to carry even more radio programs in the future [51].

Furthermore, when using its SFN architecture variant, all transmitters cover a particular predefined area with a set of programs on the same nominal frequency, that is in the same frequency block. In many cases, some transmitters radiate a slightly different multiplex in order to provide local program variation. It is vital to understand the relation between flexibility and coverage in the DAB+ network [10][45][66].

The DAB+ system is a highly flexible and dynamically reconfigurable system. It can accommodate to a large range of bitrates up to 192 kbps. Of course, the higher the bitrate, the better the quality of the audio signal. However, higher bitrates mean that there will be less radio programs in a single frequency block, called the multiplex. Naturally, some broadcasters will be particularly interested in using especially low audio bitrates per audio channel [30].

2.3.4. Additional Data Services

The DAB+ broadcasting system, aside from transmitting audio signals, can also be used to carry a large variety of either associated or independent data services in the form of text, still picture or video images. The digital platform offers much more than just audio transmission [67]. These additional services include:

1. Information about the music piece being played, i.e. lyrics, title, author, album cover.
2. Various types of entertainment and news, including upcoming events, weather forecast, traffic information, or even stock exchange quotations.
3. Advertisements and sale campaigns.

Currently, the majority of broadcasters focus on implementing services such as:

- DLS (*Dynamic Label Segment*) – text information of length up to 128 characters. It requires a simple 2-line alphanumeric text display with 32 characters in each.
- SLS (*Slideshow*) – sequences of still pictures, their order and presentation time are generated by the broadcaster. In particular, this service has the biggest potential to increase advertising revenue.
- EPG (*Electronic Programme Guide*) – a schedule very similar as in TV, which helps the user to find, select and listen to a desired radio station. It can also automatically record or set a particular programmed station. A schedule may be sent several days in advance by the broadcaster or updated any time in order to reflect the changes on air.

The standard also includes the TPEG (*Transport Protocol Experts Group*) protocol for traffic or travel information, used to inform about road conditions and traffic jams. It can provide messages in the form of either text, synthesized speech or graphically.

2.4. Quality Aspects

Broadcasting systems generally consist of different signal processing blocks. This signal processing, e.g. source coding and channel coding, may utilize different codecs and bitrates which, as a result, have a significant impact on the end user perceived quality [107]. Therefore, it is important to study how different coding schemes affect the QoS (*Quality of Service*) and QoE (*Quality of Experience*), especially under limited bandwidth resources.

In the age of digital media, when it comes to delivering audio content, the target is to distribute as many radio programs as possible within limited bandwidth resources. Of course,

the higher the bitrate, the higher the quality and user satisfaction. An appropriate balance between the number of broadcasted radio programs and their bitrate is a delicate, yet vital decision. Bitrate assignment in multimedia services is still a widely discussed topic [46][94]. It should be emphasized that terrestrial broadcasting provides the same quality for each person, regardless of the number of simultaneous users. Additional information concerning advancements in digital broadcasting and other electronic media may be found in [20][26][27].

2.4.1. Audio Coding

The current state source coding is undoubtedly the result of development of telecommunication networks and services offered by those networks. When it comes to audio signal encoding, one question arises – how much information could be lost. The main task of source encoding is to select compression parameters in a way, such that:

1. The compression ratio was as high as possible – audio material as small as possible for subsequent storage.
2. The reconstructed audio signal assessed as of high quality on the user side.

Other requirements include a low computational complexity and a wide range of application.

Audio coding and compression algorithms enable to shrink down the size of a file without seriously affecting the quality. Besides from lossy compression, every broadcast transmission causes additional degradation in quality. That is why scientists focus on developing new and efficient ways of processing the audio material, especially at low bitrates [5][50].

The MPEG-4 (*Moving Picture Experts Group*) HE-AAC v2 (*High Efficiency Advanced Audio Coding*), utilized in DAB+, is one of the most efficient audio compression algorithms. This source codec is used in a wide variety of broadcasting and streaming services worldwide. The target applications for this coding algorithm are mobile music and TV, terrestrial digital radio and TV broadcasting, Internet streaming and consumer electronics [38]. The full structure (profile) of the AAC coding algorithm is described in Fig. 2.6. The AAC codec comprises of three elements, depending on individual application demands:

1. AAC-LC (*Low Complexity*) coder – basic coding algorithm.
2. SBR (*Spectral Band Replication*) mechanism – enables to reconstruct higher frequencies of the audio signal spectrum.
3. PS (*Parametric Stereo*) mechanism – enables to reconstruct the left and right channel on the receiver side using the coded mono signal and additional information.

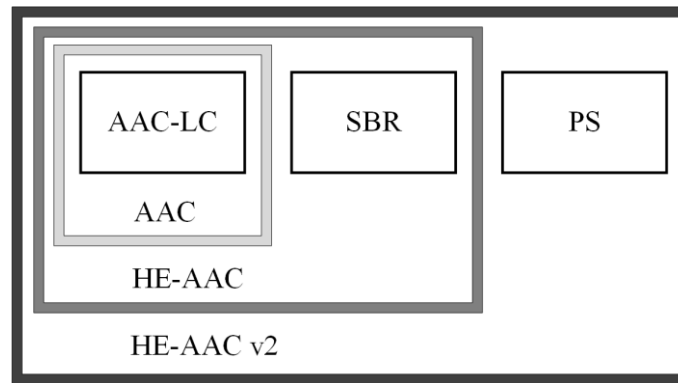

Fig. 2.6. AAC codec profile.

The AAC supports a broad range of compression ratios and configurations, ranging from mono to stereo and multichannel coding. The most popular bitrates for DAB+ services range from 64 to 128 kbps. In case of higher bitrates, the basic AAC is preferred. Whereas in case of medium bitrates, a combination of AAC-LC and SBR is recommended. For lower bitrates it is advised to use the full HE-AAC v2. The block diagram of the AAC encoder is shown in Fig. 2.7.

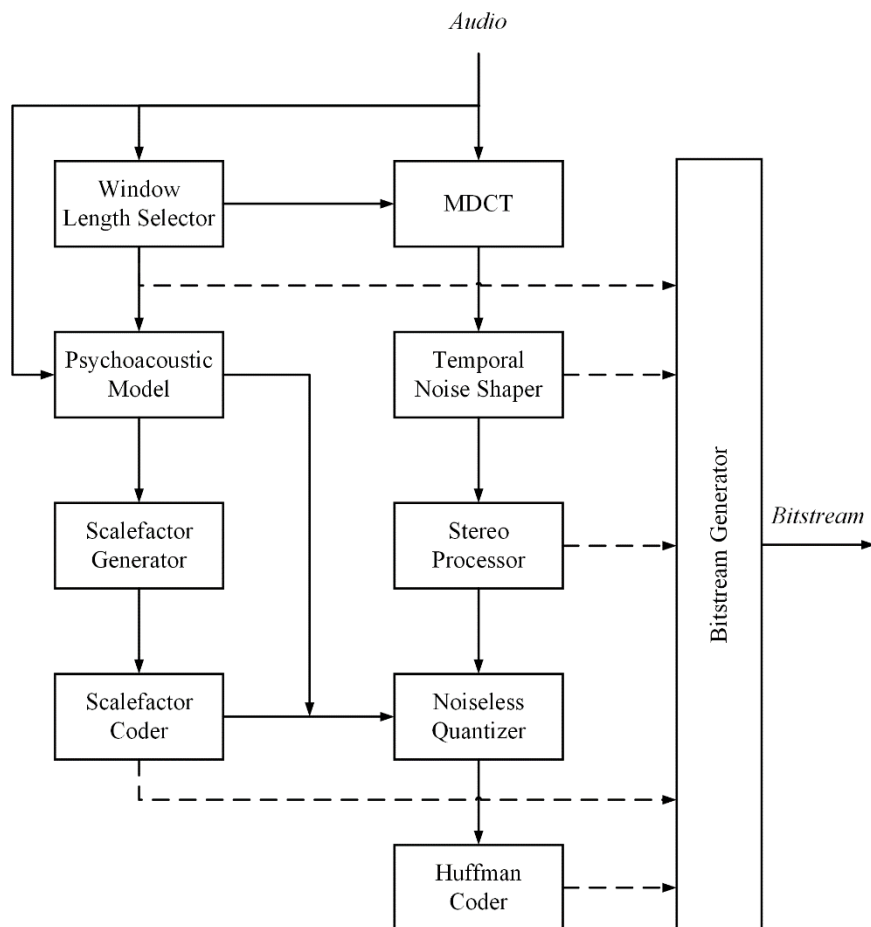

Fig. 2.7. AAC encoder.

The AAC is a transform coder, where the time-domain audio signal is transformed into a different domain that is more conducive to data reduction. It utilizes MDCT (*Modified Discrete Cosine Transform*), which produces a time-frequency representation of the audio at a finer frequency resolution. In the DAB+ broadcasting system, the codec utilizes two window sizes, namely 1920 and 240. The reason for having 2 different window sizes is to give the option of either good frequency resolution (large transform) or good time resolution (small transform). This choice depends upon the nature of the audio signal.

On the other hand, windowing can affect the frequency selectivity and rejection of the transformed signal. Once again, the nature of the audio signal can decide, whether to use a short or long transform. In this case, 2 window shapes are used, that is KBD (*Kaiser-Bessel Derived*) and sine window. The KBD window is better at separating spectral components when they are more than 220 Hz apart, whereas the sine window is better separating spectral components closer than 140 Hz to each other.

The TNS (*Temporal Noise Shaping*) filter is an optional part of the encoder. When used, it sets a flag in the bit stream, so the decoder is ready to use it.

In contrast to coding 2 independent channels, stereo processing offers more opportunities for coding gain. The AAC codec utilizes two methods of the so-called joint stereo coding: M/S (*Mid/Side*) stereo coding, also known as sum-difference, and intensity stereo coding. M/S stereo coding transforms the stereo signal (left and right) into a sum and difference pair of signals. On the other hand, intensity stereo coding utilizes magnitude weighting, since spectral values can be shared across both channels.

Scale factors are calculated by using information from the psychoacoustic model, used bitrate and bit requirements for the quantization coefficients and the scale factors themselves.

Quantization is responsible for minimizing the perceptual coding artefacts. It is driven by the psychoacoustic model, that provides information which spectral bands require more bits than others. The limit of bits available for encoding this spectral data is determined by the bitrate setting of the encoder.

Huffman coding is an efficient way of reducing numerical data, where the coding gain is achieved by the knowledge of likelihood of each data value. Therefore, Huffman coding can reduce the required data rate in a lossless way. Additional information concerning the AAC algorithm can be found in [8][9][95].

2.4.2. Quality of Service and Quality of Experience

It is assumed, that high performance and transmission quality will lead to high acceptance and usability of offered services, clearly visible in the growth of users. However, low quality or best effort systems such as SMS (*Short Message Service*) or sending e-mails have gained enormous popularity. This clearly shows that the relationship between performance, quality and acceptance of a service is not fully understood. Also the term quality can be understood in many different ways [33].

Engineers perceive the term as quality of service, which is related with network performance and reliability. But does this term, generally describing the characteristics of machines, devices and their parameters, really reflect the process of perception of a human individual. According to [49], quality can be defined from a person's point of view, which involves a process of comparing perceptual events with a known reference. The user's previous experience may in fact influence the opinion about what is actually perceived. That is why the term quality of experience has gained interest. It focuses mainly on defining the characteristics of media transmission systems or services and their acceptance by customers. Broadcasters, content providers and network operators no longer intend to deliver services with simply high QoS, but with satisfying QoE to their customers [19][39][65][90][91].

When examining the interaction between human-machine interfaces, a shift can be observed. Issues such as effectiveness and efficiency, also referred to as usability, tend towards the term UX (*User Experience*), related with the experience people have when using various interfaces. Clearly, all issues related with QoS, QoE and UX need further study in order to really describe what does the term quality mean for the typical user.

Since 2011, the European Network on Quality of Experience in Multimedia Systems and Services (COST Action IC 1003) [124], started the scientific discussion about the definition of the term quality. This multidisciplinary group, focused on quality aspects of different multimedia services, approached this problem from a different perspective. They started to extend the notion of network-centric QoS and user-centric QoE. The main scientific objective is to develop new subjective methodologies and instrumental quality metrics that would keep up with new trends in multimedia communication systems [18][48][82][83].

2.4.3. Quality in Digital Broadcasting

From a broadcaster's perspective, the term quality is a key factor for evaluating systems and services. During both the design and operation phase, the main objective is to create certain types of new experiences, that would interest the potential user. Whenever a new service is introduced, whether a substitute or intended competition, it should offer features that are unique and distinguish them from other services available on the market.

Currently, digital audio broadcasting is a well-established method for consuming content. Systems like DAB and DAB+ [103][105], DRM (*Digital Radio Mondiale*) and DRM+ (*Digital Radio Mondiale plus*) [104], or T-DMB (*Terrestrial Digital Multimedia Broadcasting*) [14][64], are intended to replace traditional analog radio. Thanks to the popularity and availability of mobile and portable devices, numerous services allow users to listen to music almost anytime and everywhere. However, network bandwidth constraints are viable across the diverse range of techniques used. As a result, content providers and broadcasters must support a wide range of codecs and bitrates in order to optimize the user perceived QoE.

Studies show that a bitrate of 256 kbps can deliver lossy compressed content that is indistinguishable from the uncompressed original file [41]. Psychoacoustic inspired compression schemes utilize signals that are optimized from the perspective of the human auditory system [17]. Efficient bandwidth management can not only enhance user experience. Any bandwidth savings can be used to introduce yet another service.

In case of digital broadcasting systems such as DAB+, the mere perceived quality is a mixture of different parameters, such as: delay, latency, channel impulse response, quantization noise or SNR (*Signal-to-Noise Ratio*). However, the most significant aspects are bandwidth limitations, which have a significant impact on the assigned bitrate of a radio program.

DAB+ was designed as a substitute or replacement for the well-known analog FM radio. It has a lot to offer, besides transmitting audio signals. The main factors that attract new users to this service are:

1. A clearly noticeable higher transmission quality.
2. A stable reception, especially in case of mobile or motorized users.
3. Easy to operate receivers with a number of additional services.

After analyzing the available literature, three broadcast quality criteria can be easily distinguished [3][59]:

1. Clarity and transparency of the audio material – this parameter particularly refers to the early days of radio transmission.
2. Broadcast quality – the overall quality is ranked as >4.0 in the MOS (*Mean Opinion Score*) or >80 in the MUSHRA (*Multiple Stimulus with Hidden Reference and Anchor*) scale.
3. FM quality – the digital standard, intended to become a substitute or replacement of analog transmission, should provide comparable or higher quality.

When designing DAB+ services it is crucial to determine whether its quality can compete with the quality offered by existing FM radio. This task can be performed using subjective and objective quality metrics.

2.4.4. Subjective and Objective Quality Metrics

The most reliable method for quality assessment is via subjective testing with a group of listeners. The ITU (*International Telecommunication Union*) provided a widely used recommendation, defining the procedure of quality tests [114]. The most frequently used is MOS [109], where listeners rate the quality of sample *B* with respect to sample *A*, as described in Tab. 2.2.

Tab. 2.2. MOS grading scale.

<i>Impairment</i>	<i>Grade</i>
Imperceptible	5.0
Perceptible, but not annoying	4.0
Slightly annoying	3.0
Annoying	2.0
Very annoying	1.0

The MOS metric has other variants, including a 5-step ACR (*Absolute Category Rating*), where listeners assess the sample with no reference, as shown in Tab. 2.3. Another one, called CCR (*Comparative Category Rating*), is a 7-step variant, where listeners rate the difference between sample *A* and *B*, as shown in Tab. 2.4.



Tab. 2.3. MOS ACR grading scale.

<i>Quality</i>	<i>Grade</i>
Excellent	5
Good	4
Fair	3
Poor	2
Bad	1

Tab. 2.4. MOS CCR grading scale.

<i>Comparison</i>	<i>Grade</i>
<i>B</i> is much better than <i>A</i>	+3
<i>B</i> is better than <i>A</i>	+2
<i>B</i> is slightly better than <i>A</i>	+1
<i>A</i> is the same as <i>B</i>	0
<i>A</i> is slightly better than <i>B</i>	-1
<i>A</i> is better than <i>B</i>	-2
<i>A</i> is much better than <i>B</i>	-3

Recently, a new methodology called MUSHRA [112], is gaining popularity. MUSHRA allows listeners to compare treatments and rank them on a continuous scale from 0 to 100, as described in Tab. 2.5. They are presented with a labeled reference signal and a number of unlabeled test samples, so-called stimuli, including 1 or 2 anchors, being a 3.5 kHz or 7 kHz LPF (*Low-Pass Filter*) processed version of the reference signal. Biases in MUSHRA have been investigated [97], but this methodology has been used in a variety of tests showing a good ability to rank low bitrate codecs.

Tab. 2.5. MUSHRA grading scale.

<i>Quality</i>	<i>Grade</i>
Excellent	81-100
Good	61-80
Fair	41-60
Poor	21-40
Bad	0-20

Of course, MOS or MUSHRA scores can vary, based on cultural or language issues, number of listeners, or even test conditions. That is why usually the range of tested audio samples is limited, depending on the interest for a specific research topic. Compared with objective testing automated by software, subjective testing is viewed as expensive and time consuming. As a result, objective test metrics have been developed and remain a topic of active research.

Broadcasters and telecoms want to evaluate the quality of speech and music signals of offered services. This is a crucial issue for the whole process of planning, as well as implementation, monitoring and maintenance purposes.

Objective metrics can be classified into two main categories: parameter-based and signal-based methods, as shown in Fig. 2.8. Parameter-based methods do not test signals over the channel but instead predict the quality through modeling the channel parameters. On the other hand, signal-based methods predict the quality based on evaluation of a test signal at the output of the channel. Signal-based methods can be further divided into two subcategories: intrusive and non-intrusive methods.

Intrusive methods use an original reference signal and compare it with a degraded signal, representing the output signal of the tested system. The PSQM (*Perceptual Speech Quality Measure*) was the first attempt to model a human listener and predict the perceived quality [115]. Later on, new objective quality metrics for speech and music signals have emerged, including PESQ (*Perceptual Evaluation of Speech Quality*) [116] and PEAQ (*Perceptual Evaluation of Audio Quality*) [111], which allow to predict the quality by comparing a reference signal to a received signal.

PESQ was developed first to provide an objective estimate of narrowband speech, and was later extended for wideband speech [117]. On the other hand, PEAQ has two versions, one optimized for speech and the other that adds a filterbank-based ear model to the basic FFT-based model in order to improve accuracy. Both versions produce the output in the form of an ODG (*Objective Difference Grade*) quality score, which is an objective approximation of the SDG (*Subjective Difference Grade*) score used to determine small audio impairments.

A decade later, ITU standardized a new objective metric, POLQA (*Perceptual Objective Listening Quality Assessment*) [118]. It was initially designed for speech quality assessment for VoIP (*Voice over IP*) in narrowband (300 – 3400 Hz) or superwideband (50 – 14000 Hz) mode. However, it proved to be quite accurate as an audio quality model [78].

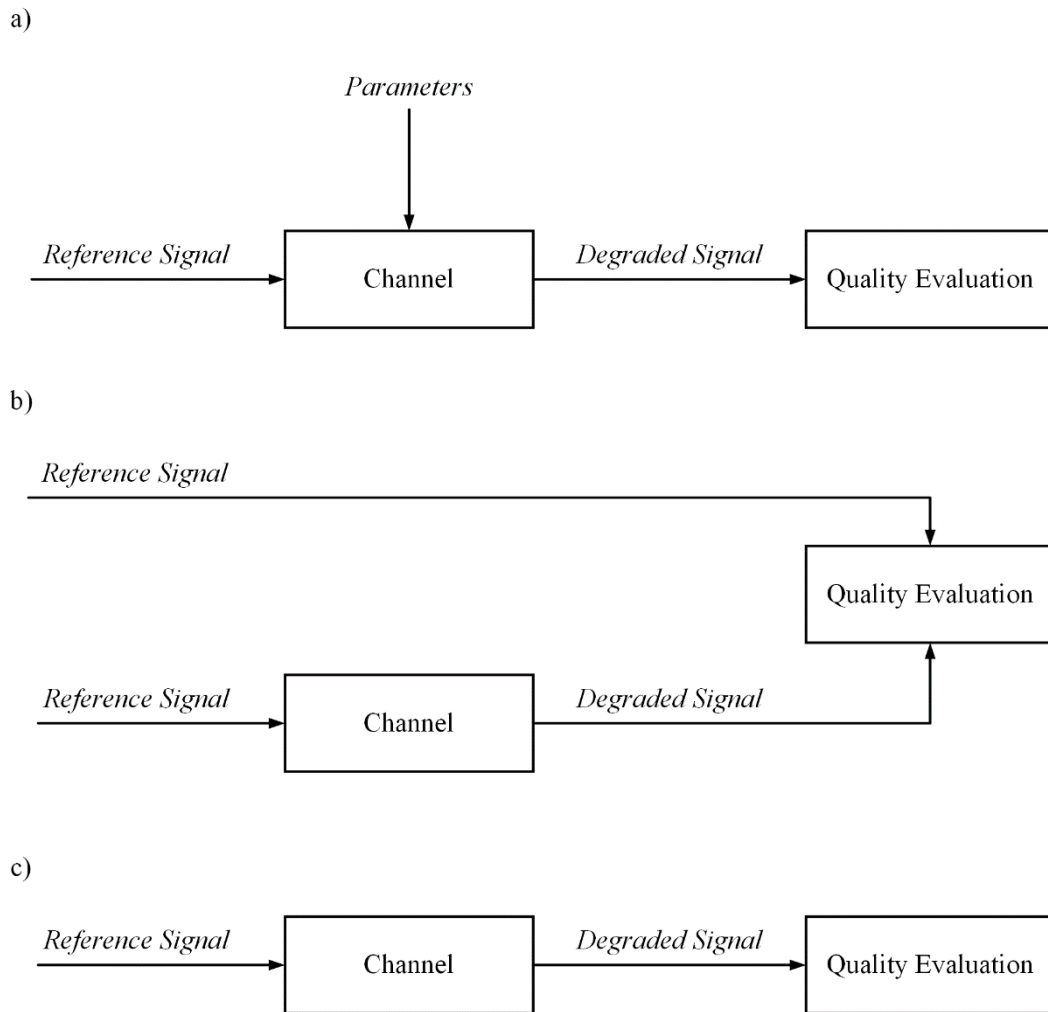

Fig. 2.8. Objective quality metrics: a) parameter-based, b) signal-based intrusive, c) signal-based non-intrusive.

In comparison to intrusive methods, one of the most widely used non-intrusive models is ANIQUE+ (*Auditory Non-Intrusive Quality Estimation plus*), a signal-based method used to predict the quality without access to any reference signal [99]. The ITU has also introduced its recommendation [113]. It can be noticed, that this topic is still an active area of research.

Recently, an alternative speech quality model, called ViSQOL (*Visual Speech Quality Objective Listener*), has been developed for quality assessment in narrowband (150 – 3400 Hz) and wideband (50 – 8000 Hz) mode [42]. It is a full-reference speech metric, comparable to POLQA, that uses similarity between spectrograms to measure quality. Its fullband adaptation, called ViSQOLAudio, enables to assess the quality of both speech and music signals in a 5-step MOS scale [40]. An extensive review of objective quality models can be found in [73]. Biases encountered in modern audio quality listening tests are discussed in [98].



Chapter 3: Resource Allocation in DAB+

In the age of digital media, delivering DAB+ broadcast content to consumers, at an acceptable level of quality, is one of the most challenging tasks. The most important factor is the efficient use of available resources in a single 1.5 MHz frequency block within a particular ensemble configuration. An appropriate way of handling multiplex resources is an essential factor, for both the economic and technical issues.

The DAB+ standard has broad capabilities of regionalization, i.e. one nationwide service could be sacrificed in favor of a number of regional services. Of course, any introduction of digital radio requires a simulcast, which means a duplicated terrestrial transmission of both analog and digital radio for some period of time. The initial costs of such an experiment are considered as high, however in the long run, the costs for a single digital radio program are far less per capita than for an analog radio program.

3.1. DAB+ Multiplex

The DAB+ broadcasting system was designed to deliver content in frequency range from 30 MHz to 3 GHz and operate in 1 out of 4 transmission modes. The generation of the DAB+ multiplex is shown in Fig. 3.1.

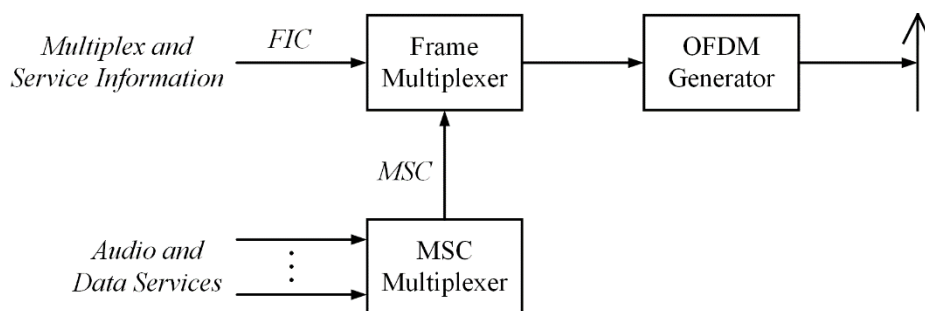

Fig. 3.1. Generation of the DAB+ multiplex.

Signals containing data of audio and additional service components are carried in the MSC. Every 24 ms, all data are gathered in sequences, referred to as CIFs. The data concerning the multiplex and service-related information is carried in the FIC, which are combined into FIBs. Later on, CIFs and FIBs are grouped together into one transmission frame, which is mapped to a number of OFDM symbols, depending on the transmission mode. Thanks to its flexibility, the multiplex may be reconfigured from time to time during transmission.

3.1.1. Logical Structure

Different data streams carried in the DAB+ multiplex can be grouped together to form a service. The service can be labeled, e.g. *Program 1*, *Program 2*, *News*, *Sport*, *Journaline*, etc., and though this label it is available to the listener. All services grouped together are referred to as an ensemble.

Different data streams, e.g. audio, data, etc., which belong to one service, are called its service components. Different services may share components, and the logical structure of services, service components and the position in the CIF where data of each component are actually carried is signaled as part of the MCI (*Multiplex Configuration Information*) in the FIC. An exemplary logical structure of the DAB+ multiplex is shown in Fig. 3.2.

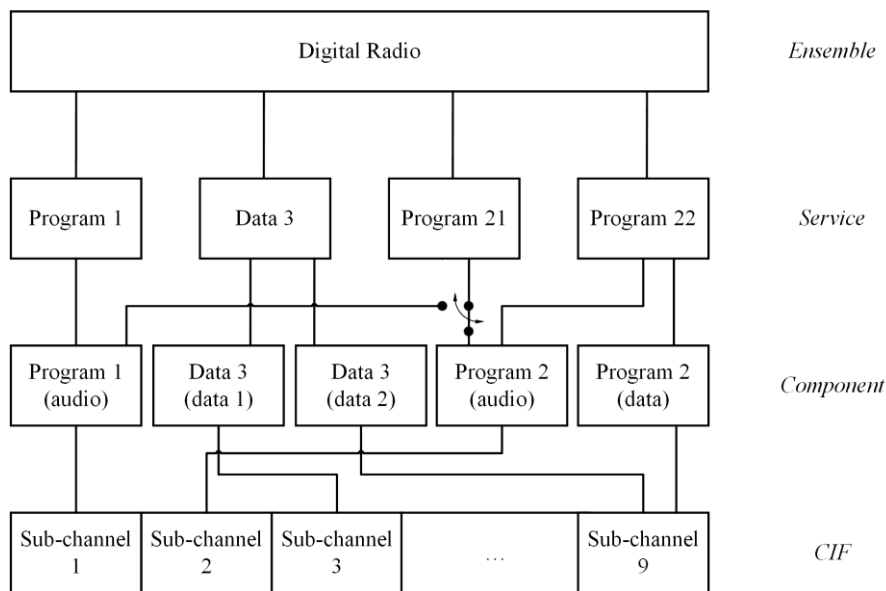

Fig. 3.2. Logical structure of the DAB+ multiplex.

The ensemble labelled *Digital Radio* contains 4 services, namely: *Program 1*, *Data 3*, *Program 21* and *Program 22*. *Program 1* is a service, which consists of an audio component only. It is considered as a normal or typical radio program. In case of *Program 21*, it consists of an audio component as well. However, from time to time, i.e. during a news broadcast every hour, it transmits the same audio signal as *Program 1*. Instead of transmitting the corresponding bits twice, it is possible to signal this at the level of service components. *Program 22* consists of an audio and data component, which carries information relevant to the program. *Data 3* is a data service without an audio component, but with two separate data components instead, e.g. traffic information (data 1) and weather forecasts (data 2). As presented, different components, that is *Data 3* (data 2) and *Program 2* (data), may share a packet mode sub-channel, while stream mode components each require an individual sub-channel.

3.1.2. Current Ensemble Configuration

On August 2016, the DAB+ multiplex in Gdańsk operated on channel 10D (215.072 MHz), transmission mode I. The configuration of the ensemble is described in Tab. 3.1. Each service had a EEP 3-A error correction and a coding efficiency of $\frac{1}{2}$.

According to the analysis, 672 CUs were allocated, where 648 were utilized for audio and 24 for data services, whereas 192 CU remain free, as shown in Fig. 3.3.

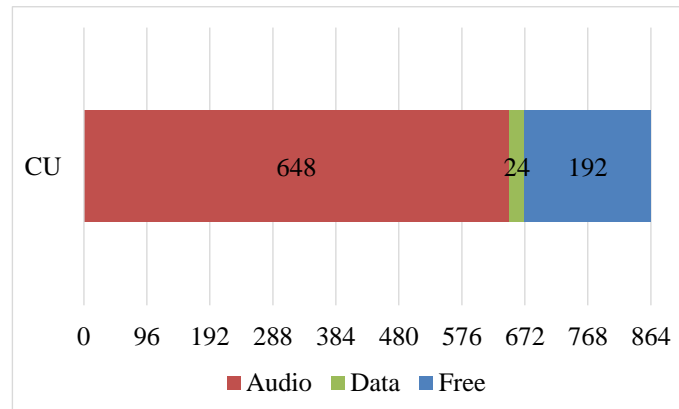

Fig. 3.3. Ensemble CU allocation.

All 11 services available in the ensemble occupied a total of 896 kbps, whereas 256 kbps remained free, as shown in Fig. 3.4.

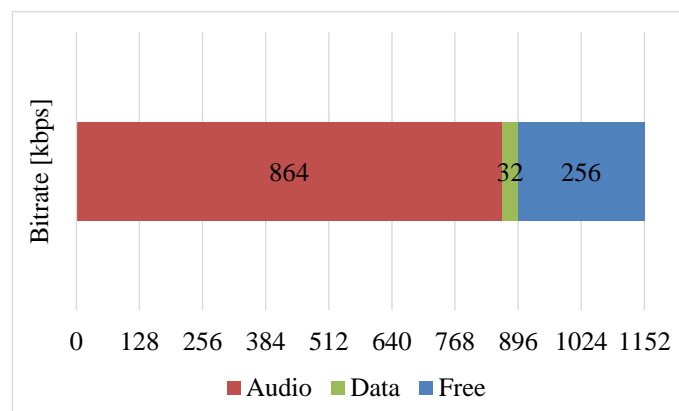

Fig. 3.4. Ensemble bitrate assignment.

Between October and December 2015, these free resources were used for broadcasting two periodical radio programs, so-called pop-ups, namely *Radio Chopin* and *Radio Gwiazdka*.

Tab. 3.1. DAB+ ensemble configuration in Gdańsk (August 2016).

No.	Service	Profile	Audio codec	Bitrate [kbps]	Net Bitrate [kbps]	Audio [kbps]	Audio [%]	PAD [kbps]	PAD [%]	Sub- channel	No. of CUs	Start CU	Stop CU
1	PR Jedyńka	Talk 1	AAC-LC	112	101.1	94.3	93.2	6.8	6.8	1	84	0	83
2	PR Dwójka	Arts	AAC-LC	128	115.8	109	94.1	6.8	5.9	2	96	84	179
3	PR Trójka	Talk 2	AAC-LC	112	101.1	94.3	93.2	6.9	6.8	3	84	180	263
4	PR Czwórka	Pop Music	AAC-LC	112	101.1	94.3	93.2	6.8	6.8	4	84	264	347
5	Radio Poland	Informative EN	AAC-LC	64	57.1	53.4	93.5	3.7	6.5	5	48	348	395
6	Polskie Radio 24	Informative PL	HE-AAC v1	64	57.9	54.8	94.8	3	5.2	6	48	396	443
7	Radio Rytm	Electronic Music	HE-AAC v1	96	87.2	83.4	95.7	3.8	4.3	7	72	444	515
8	Radio Gdańsk	Regional	AAC-LC	104	93.8	86.2	91.9	7.6	8.1	8	78	516	593
9	Radio Dzieciom	Children	HE-AAC v1	72	65.2	61.4	94.2	3.8	5.8	9	54	594	647
10	Data	-	-	16	-	-	-	-	-	10	12	648	659
11	Journaline	-	-	16	-	-	-	-	-	11	12	660	671

3.1.3. Bitrate Assignment

The development of digital media technologies has influenced a wide area of technology, including digital broadcasting systems and services. The growth of processed data implies a necessity to apply some lossy compression algorithms in order to manage limited bandwidth resources as efficient as possible. Because parts of the signal are lost during compression, it is necessary to control the quality of audio signals in order not to introduce any audible distortions.

The quality of speech and music signals is a complex psycho-acoustical phenomena, related with human perception. It is worth mentioning that each person interprets quality in a different way [75]. According to available scientific papers, test results give some directions when it comes to designing digital broadcasting services and allocating resources.

As presented in [4][7][55], the spatial attributes of sound rapidly get worse for bitrates lower than 96 kbps, while the sound color remains almost the same for a wide range of bitrates from 64 to 136 kbps. Sufficient sound quality can be obtained for bitrates of 64 to 136 kbps, but with SBR for the lowest one. The same remarks were given for processed speech signals.

In [3], authors compare the quality offered by analog FM and digital DAB+ broadcasting systems in two test scenarios. In the first test scenario, signal samples processed at bitrates of 96, 128 and 160 kbps did not fulfill the broadcast quality criterion. The criterion was only fulfilled for content processed at 192 kbps. In the second test scenario DAB+ offered quality comparable to that of FM at bitrates of 160 kbps and higher.

According to [79], authors investigate the impact of different audio codecs utilized in popular digital audio broadcasting and webcasting applications, as well as the degradation introduced by lossy compression algorithms, including MP2, AAC-LC, Opus, MP3, HE-AAC v2 and Ogg Vorbis. The highest scores were observed for signal samples coded using HE-AAC v2 and Ogg, with HE-AAC v2 providing the best quality even for lower bitrates, including 24 kbps. In comparison, Ogg provided similar results at 64 kbps.

In [25][32], authors investigated user expectations with respect to currently available digital broadcasting and streaming services. This investigation was followed by an objective quality study of currently available services, simulcasted terrestrial and online. According to obtained results, services available at bitrates between 48 and 128 kbps, coded using the AAC algorithm, can provide an overall quality ranked as good.

According to the study in [36], the DAB+ broadcasting system offers superior quality compared with traditional FM radio transmission. In case of 5 simulcasted programs, both in

DAB+ and FM, of different profiles, i.e. classical music (*Arts* – 128 kbps), two of a general profile (*Talk 1* and *Talk 2* – 112 kbps each), popular music (*Pop Music* – 112 kbps) and regional (*Regional* – 104 kbps), the overall quality of DAB+ was ranked as higher.

3.2. Quality Assessment Study

As it was noticed, some radio programs are simulcasted both in analog FM and digital DAB+, whereas newly introduced programs are available in DAB+ and online. Moreover, concerning the broad range of radio programs, their profiles and target groups, as well as the number of different music genres, it was decided to carry out an experiment consisting of 5 parts:

1. Subjective quality assessment of real-time DAB+ broadcasted radio programs.
2. Subjective comparative quality assessment of DAB+ radio programs with respect to simulcasted FM programs.
3. Subjective quality assessment of new radio programs available on the DAB+ multiplex.
4. Objective and subjective quality assessment of signal samples processed with the AAC codec at different bitrates.
5. Questionnaire concerning the switchover from analog to digital radio domain.

The subjective tests were carried out according to recommendation [110] with a short break between each part, whereas the objective tests were performed using the ViSQOLAudio algorithm. This novel metric, comparable to the well-known POLQA, enables to assess the quality of signal samples in a 5-step MOS scale. Parts 1-3 were performed using a commercially available FM/DAB+ radio receiver.

The test was performed on a group of 45 people, aged between 18 and 25 years old. None of them had hearing disorders. Each person assessed the quality individually and was informed about the aim and test scenario. All participants took a training phase before starting the essential listening test in order to learn the functionality of the user interface and become familiar with the listening equipment. Tests were performed in turns, one individual after another. A single session took approx. 20-25 minutes. Listeners were allowed to adjust the volume according to their preferences. They were not informed about the name and bitrate of the assessed radio program or signal sample. Only the profile of the current ranked radio program was given. Tests were conducted using AKG K550 closed-back headphones, as measuring with loudspeakers introduced a risk that room acoustics could influence the results.

3.2.1. Real-Time DAB+ Broadcasted Radio Programs

Listeners were asked to rate the overall quality of each real-time transmitted DAB+ radio program, over a period of approx. 10-20 s, in a 5-step MOS ACR scale. The profile and bitrate of each assessed radio program is described in Tab. 3.2. The subjective results are shown in Fig. 3.5.

Tab. 3.2. Profile and bitrate of assessed DAB+ radio programs.

Profile	Bitrate [kbps]
Talk 1	112
Arts	128
Pop Music 1	112
Talk 2	112
Regional	104

There was one radio program dedicated to classical music (*Arts*), two of a general profile (*Talk 1* and *Talk 2*), one program transmitting particularly popular music (*Pop Music 1*) and one regional (*Regional*).

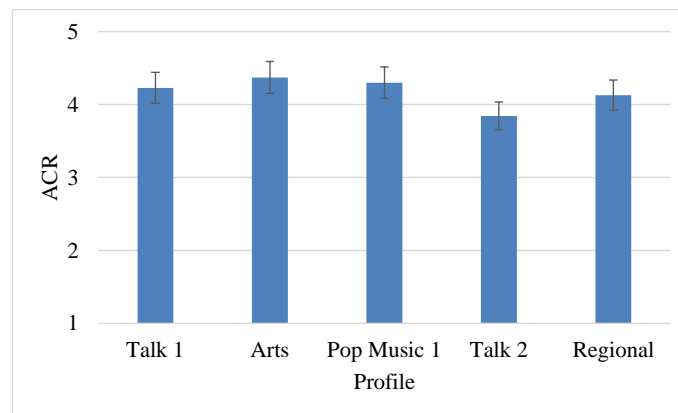

Fig. 3.5. Subjective quality assessment of real-time DAB+ broadcasted radio programs.

According to the results, the overall quality was ranked as good. This can be viewed as a confirmation, that the bitrate, assigned for each individual program, was chosen appropriately. Since digital radio is less vulnerable to multipath effects and noise, the DAB+ broadcasted programs were reported as free from interference. This means that currently both the QoS and QoE aspects meet user expectations.

3.2.2. Simulcasted DAB+ and FM Radio Programs

Next, each individual was asked to compare the quality of DAB+, as described in Tab. 4.1, and FM broadcasted programs. They were asked to rate the DAB+ audio material (sample *B*) with respect to FM audio material (sample *A*) in a 7-step MOS CCR scale. The samples were presented to the listeners in a single *A–B* pair, over a period of approx. 10-20 s, separated by a 0.5-1 s interval. Each pair, representing the same simulcasted radio program, was rated separately. The subjective results of this comparative study are shown in Fig. 3.6.

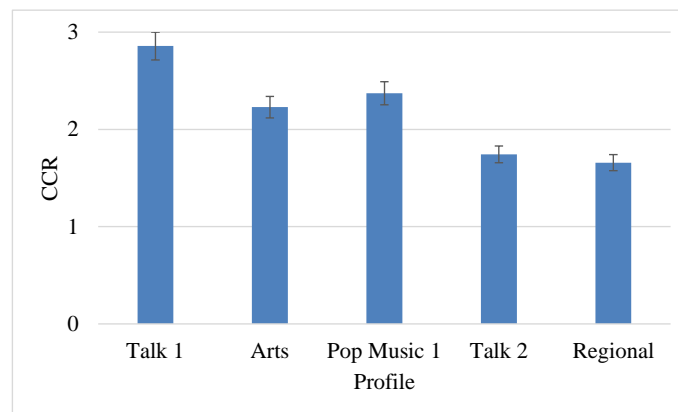

Fig. 3.6. Subjective comparative quality assessment of DAB+ radio programs with respect to simulcasted FM programs.

According to the obtained results, in case of each DAB+ radio program there was a clearly noticeable increase in quality. This indicates, that the current quality offered by DAB+ surpasses that of FM. Furthermore, the CCR method can be viewed as more accurate than ACR, because it enables listeners to distinguish little differences between two audio samples. It can be noted, that when comparing digital DAB+ with analog FM transmission, the relation between bitrate and quality evaluation is not linear.

3.2.3. New Radio Programs

Afterwards, listeners were asked to rate the overall quality of each new real-time transmitted DAB+ radio program, over a period of approx. 10-20 s, in the MOS ACR scale. The profile and bitrate of new radio programs available on the DAB+ digital multiplex, is described in Tab. 3.3. These 5 new DAB+ programs were dedicated to different audiences. One of them for the youngest listeners, 2 for adults interested in current affairs, both in Polish and English. The remaining 2 were programs playing popular (in fact, it consisted mostly of electronic music) and classical music.

Tab. 3.3. Profile and bitrate of assessed new DAB+ radio programs.

Profile	Bitrate [kbps]
Children	72
Informative EN	64
Informatiive PL	64
Pop Music 2	96
Periodical	128

It should be understood that the nature of the broadcast material might change in time with future changes in musical styles and preferences. The subjective results of this study are shown in Fig. 3.7.

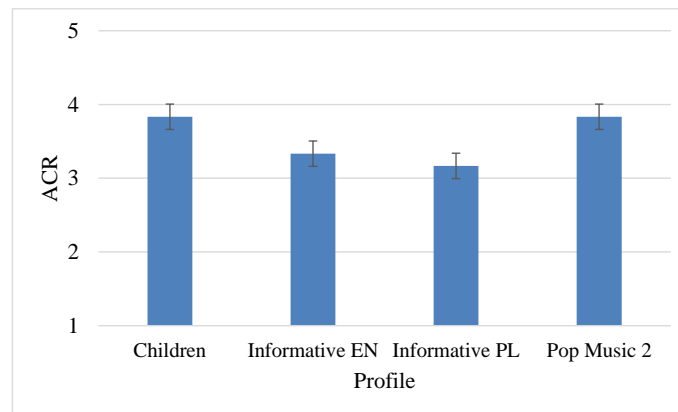

Fig. 3.7. Subjective quality assessment of new radio programs available on the DAB+ multiplex.

According to the listeners, the overall quality of new DAB+ terrestrial digital radio programs was ranked between fair and good. This indicates that some minor adjustments in bitrate assignment could help to increase the perceived quality.

3.2.4. Signal Samples Processed with the AAC Codec

In this part of the study, the group of audio samples was divided into 4 categories:

1. Musical instruments – castanets, vibraphone, guitar.
2. Speech and singing – lector female and male speech, as well as soprano (high female voice), tenor (high male voice) and quartet (soprano, alto, tenor, bass).
3. Music genres – a choir and symphony orchestra piece, one electronic and one popular music piece.

4. Popular music – well known songs of Michael Jackson, Jamiroquai and Queen, two from each artist.

The test materials from categories 1-3 were sourced from the EBU SQUAM CD [102], whereas the samples from category 4 came from a private music library. All reference samples were created as PCM (*Pulse Code Modulation*) WAV files sampled at 48 kHz, 16 bit stereo. The degraded samples were coded at different bitrates using the AAC algorithm. The sampling frequency was set to 48 kHz. All music files were available for the listeners during training phase. A detailed description of test signals is given in Tab. 3.4.

Tab. 3.4. Audio test signals used in the subjective and objective tests.

<i>Category</i>	<i>File name</i>	<i>Duration [s]</i>	<i>Description</i>
Musical instruments	Castanets	20	Castanets solo
	Vibraphone	15	Vibraphone solo
	Guitar	16	Guitar solo
Speech and singing	Female Speech	23	Female lector in English
	Male Speech	22	Male lector in English
	Soprano	28	Female singing (higher voice) acapella
	Tenor	29	Male singing (lower voice) acapella
	Quartet	28	Female and male singing (soprano, alto, tenor, bass) acapella
Music genres	Choir	31	Choir with symphonic orchestra
	ABBA	33	ABBA electronic music
	Eddie Rabbitt	21	Guitar with two male singing
Popular music	Billie Jean	27	Popular music piece by Michael Jackson
	Thriller	20	Popular music piece by Michael Jackson
	Little L	24	Popular music piece by Jamiroquai
	Runaway	22	Popular music piece by Jamiroquai
	A Kind of Magic	24	Popular music piece by Queen
	Bohemian Rhapsody	25	Popular music piece by Queen

Currently, the digital DAB+ multiplex in Poland offers radio programs transmitted at 6 bitrates: 64, 72, 96, 104, 112 and 128 kbps. For the purpose of this test, the signal samples

have been processed using the AAC source codec at 4 bitrates, with a step of 32 kbps, that is: 64, 96, 128 and 160 kbps.

Tests were carried out in turns, one participant after another, with a short break between each group of audio signals. The signal samples coded at different bitrates were separated by a 0.5-1 s interval. Each individual received the same set of instructions. The actual bitrate of the processed audio material was never mentioned. The results of both objective and subjective quality assessment for each category are shown in Fig. 3.8. Obtained subjective results have been treated with the ANOVA (*Analysis of Variance*) statistical analysis, as shown in Tab. 3.5. The confidence interval was set to 95%.

Tab. 3.5. ANOVA test results.

Category	α	P	F_{crit}	F
Musical instruments	0.05	0.16	4.26	2.23
Speech and singing	0.05	0.07	3.06	2.66
Music genres	0.05	0.62	4.26	0.51
Popular music	0.05	0.45	2.77	0.99

The classical approach to statistical analysis imposes models, both deterministic and probabilistic, on the data. Deterministic models include e.g. regression models and analysis of variance models. The most common probabilistic model assumes, that errors about the deterministic model are normally distributed, which affects the ANOVA F test [74][84].

Classical techniques such as ANOVA are generally quantitative in nature. The ANOVA provides a formal F test for the factor effect. The F statistic is the mean square for the factor divided by the mean square for the error. This statistic follows an F distribution with $(k - 1)$ and $(N - k)$ degrees of freedom. If the F CDF (*Cumulative Distribution Function*) for the factor effect is greater than 95%, then the factor is significant at the α 5% level. The F value is significant at a given level of confidence, greater than the F_{crit} cutoff value in a F table, then there is a level effect present in the data.

For estimation purposes, it is assumed that data can be adequately modeled as the sum of a deterministic component and a random component. Furthermore, it is assumed, that the fixed (deterministic) component can be modeled as the sum of an overall mean and some contribution from the factor level. Finally, it is assumed that the random component can be modeled with a Gaussian distribution with fixed location and spread.

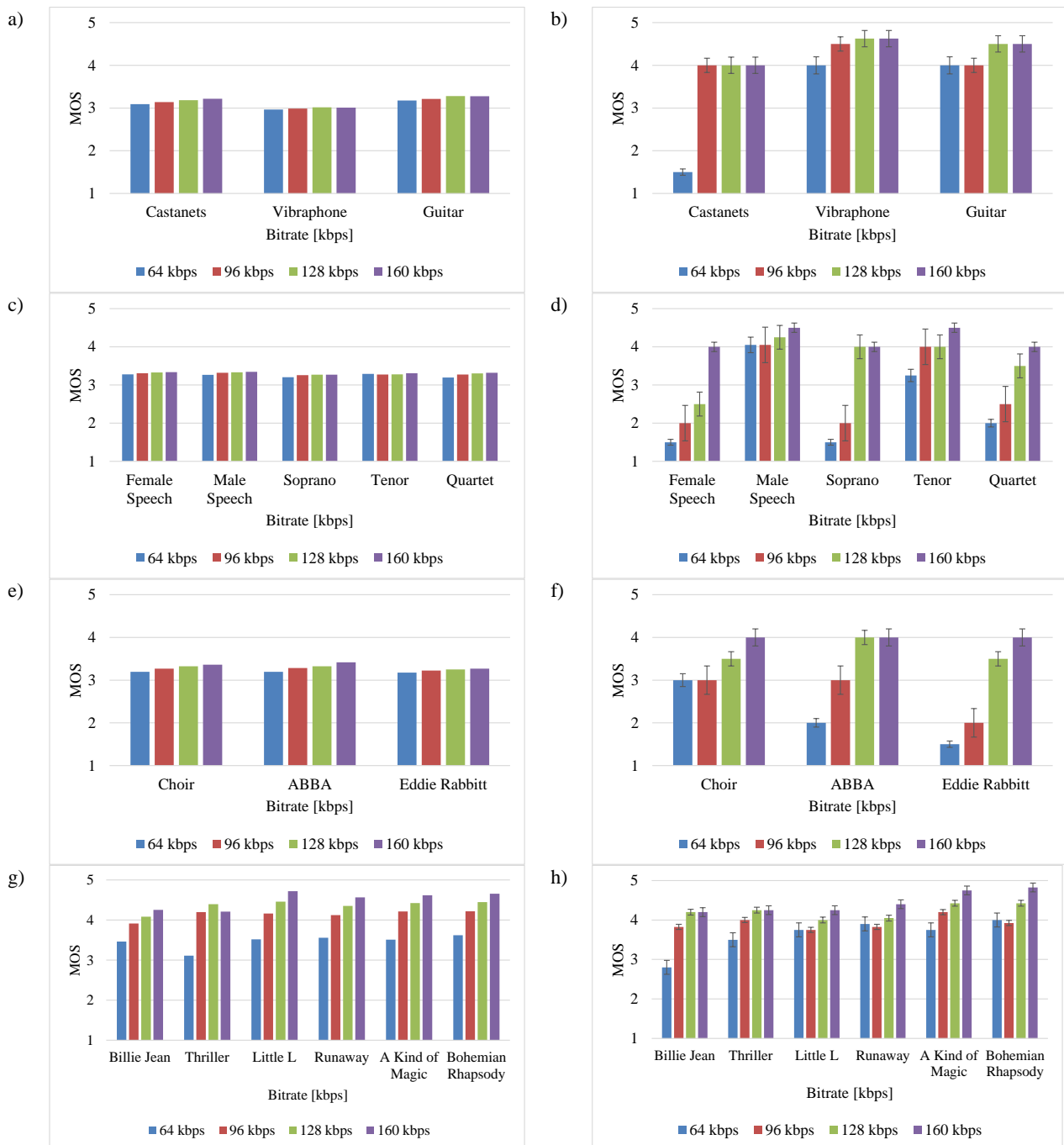

Fig. 3.8. Quality assessment of AAC processed signal samples:

- a) objective results – musical instruments, b) subjective results – musical instruments,
- c) objective results – speech and singing, d) subjective results – speech and singing,
- e) objective results – different music genres, f) subjective results – different music genres,
- g) objective results – popular music, h) subjective results – popular music.

That is why the ANOVA analysis is useful when comparing the effect of a factor with multiple observations. The factor can be either discrete or continuous in its nature. According to obtained results, in each case the probability P value was not less than α . Additionally, the F

value did not exceed the F_{crit} . This proves that the hypothesis cannot be rejected. Additional information on statistical analysis can be found in [54][69][76].

In case of *Castanets*, significant distortions and artefacts have been noticed, especially for lower bitrates. When considering the clarity of the audio material, both *Vibraphone* and *Guitar* received high grades, regardless of chosen bitrate. Furthermore, the AAC codec proved to be much more efficient when it comes to processing audio material containing lower (*Male Speech* and *Tenor*) than higher spectrum range (*Female Speech* and *Soprano*). It was noticed, that lower bitrates led to numerous distortions, perceived as an artificial, metallic and unnatural voice.

In case of music pieces with a clear stereo separation for left and right channel, it was necessary to use higher bitrates. According to the listeners, there was a clearly noticeable effect of a limited scene with a clear cutoff of lower and higher frequencies. This had a significant impact on the overall assessed quality. The same remarks were given in case of popular music pieces. Bitrates of less than 128 kbps sometimes proved to be insufficient when it comes to providing high-quality audio content.

The objective quality metric proved to be much more accurate when analyzing popular music samples from category 4 than samples from category 1-3. In case of samples from category 4, the software assumption very much resembled scores given by human listeners. On the other hand, the predictions given for samples from category 1-3 were less precise. The score did not vary much, regardless of chosen bitrate.

When analyzing speech or singing samples, the most important issue was clarity and transparency of the audio material, since information contained in the voice must reach the listener. According to the subjects, the sound color was significantly worse for samples coded at lower bitrates, especially 64 kbps. This impression was given regardless of the music genre.

The loss of high frequencies and loss of attack of the transient were also perceived. Furthermore, as the listeners indicated, in case of signal samples from category 3-4, spatial attributes of sound, including spaciousness, sound perspective and localization stability, were reported as annoying or even unacceptable for bitrates lower than 128 kbps. This effect was less common for electronic music pieces, as it was for classical or popular music.

In case of electronic music pieces, some effects such as distortion, unnatural and metallic sound, or even a cutoff of lower or higher frequencies, were viewed by some listeners as intentional.

3.2.5. Switchover from Analog to Digital Radio Domain

After finishing the listening tests, participants were asked to give answers to two questions in the form of a closed multiple-choice tests, and rank the answers according to their importance from 1 (least important) to 3 (most important). If the digital DAB+ standard would replace the well-known analog FM radio in the nearest future, it seemed quite interesting to learn what people thought about this switchover and what would encourage them to migrate from the analog to digital radio domain.

In the first question they were asked what would encourage them, taking into account the ecological, economical and practical aspect, to change or buy a new DAB+ radio receiver. In the second question, which of the switchover criteria they considered as most important. The results of this questionnaire are shown in Fig. 3.9.

According to obtained results, the most crucial factor were additional services offered by DAB+. It was quite interesting to notice, that aspects such as functionality and price of a new radio receiver came *ex aequo* at second place with exactly the same number of votes.

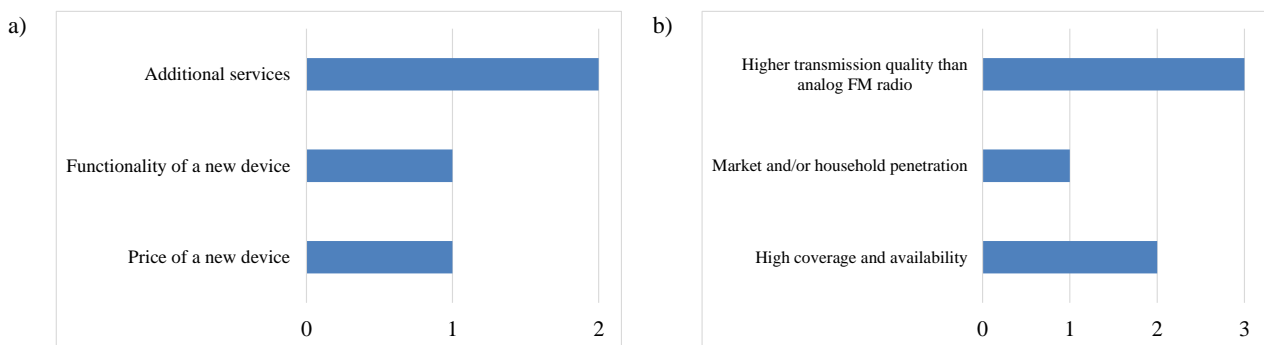

Fig. 3.9. Questionnaire concerning the switchover from analog to digital radio domain:

- factors that would encourage people to buy a new DAB+ radio receiver,
- most important switchover criteria for migrating from analog to digital radio.

Achieving higher transmission quality than analog FM radio was ranked as the most important switchover criteria. The later answers were aspects such as high coverage and availability of the digital radio signal and market and/or household penetration. It is vital to understand, that in order to successfully introduce DAB+, any service needs to offer quality on a superior level to other contemporary services. Additional information concerning user expectations related with DAB+ may be found in [31][96], whereas analyses focused on the process of digitizing radio are available in [58][62][70].

3.3. Discussion

According to the study, the DAB+ broadcasting systems offers superior quality compared with traditional FM radio transmission. This fact is considered as one of the crucial aspects when it comes to thinking about a nationwide migration from analog to digital radio domain. DAB+ has all the required capabilities to become an efficient replacement for traditional analog FM broadcasting systems.

Of course, analog FM radio, thanks to its widespread and availability, will be used for many more years. Until now, only few countries are considering a total switchover from analog to digital radio domain in the nearest future. Norway, as one of the first, planned its switchover for 2017 [121]. This fact should lead to an increase of available mobile and household hybrid FM, DAB+ and Internet radio receivers.

The results show that there is a need for continuous development of objective quality metrics. ViSQOLAudio proved to be a reliable and helpful tool. It can provide valuable feedback during the development and evaluation of any test. However, no objective metric can replace the actual evaluation of user perceived quality.

Furthermore, future studies, e.g. concerning different target groups, are required in order to meet the needs of all listeners. This will inevitably affect the level of user satisfaction. Whenever thinking about development, introduction or maintenance, providing high quality QoS and QoE parameters, especially under limited bandwidth resources, remains a key aspect of any broadcasting system. Of course, efficient bitrate assignment, related with the number of radio programs in a single multiplex ensemble, is still one of the most important factors under restricted bandwidth conditions.

Despite diligent search, no scientific papers, concerning the topic of introducing an adaptive bitrate assignment method for the DAB+ broadcasting system, were found. Moreover, there are no recommendations or guidelines concerning bitrate assignment or resource allocation for particular radio programs, based on either profile or transmitted content. This is a crucial factor, especially when it comes to dividing multiplex resources among a number of services, both audio and data, available in a single ensemble.



Chapter 4: SMOC Adaptive Multiplexing Method

According to [100], the Polish regulator distinguishes different kinds of broadcasters, including public and private ones. Later on, they are divided into regional and national broadcasters, transmitting full-time or part-time, e.g. current news and affairs, entertainment, education, etc. Based on this, a simulation has been carried out, concerning bandwidth management, particularly bitrate assignment and resource management in a single multiplex according to the proposed SMOC (*Speech, Music, Other, Commercial*) method, with respect to different ensemble configurations. As mentioned before, the Polish NBC (*National Broadcasting Council*) intends to launch 3 multiplexes. It can be estimated, that these 3 multiplexes will, in some sort, resemble the situation of the currently available program offer in analog FM radio and digital DVB-T (*Digital Video Broadcasting – Terrestrial*) television. During this analysis, the term resources will be referred to kbps instead of CU, since radio programs are available to the end user (listener) in this unit.

4.1. The SMOC Method

Based on carried out analyses, a new adaptive bitrate assignment and resource allocation method, designed for managing multiplex resources of the DAB+ broadcasting system, has been developed. The proposed method, called SMOC, comprises of 4 steps [28]:

1. Service analysis – determine the number of available services, their profile and assigned CU resources (bitrate).
2. Service classification – determine the type of service and transmitted content.
3. Assign priority – assign importance level to different types of transmitted content.
4. Assign bitrate – based on importance of transmitted content.

The relationship between content, priority and bitrate assignment is described in Tab. 4.1. What is worth mentioning, the adaptive forming of the multiplex ensemble, including content management, would be performed on the transmitting side of the radio link.

Tab. 4.1. SMOC content management.

Content		Priority	Bitrate [kbps]
Speech		1	64
Other		2	72
Commercial		3	72
Music	Electronic	4	96
	Popular	5	112
	Classical	6	128

The receiving side, including the user device, would remain untouched. The SMOC algorithm is shown in Fig. 4.1.

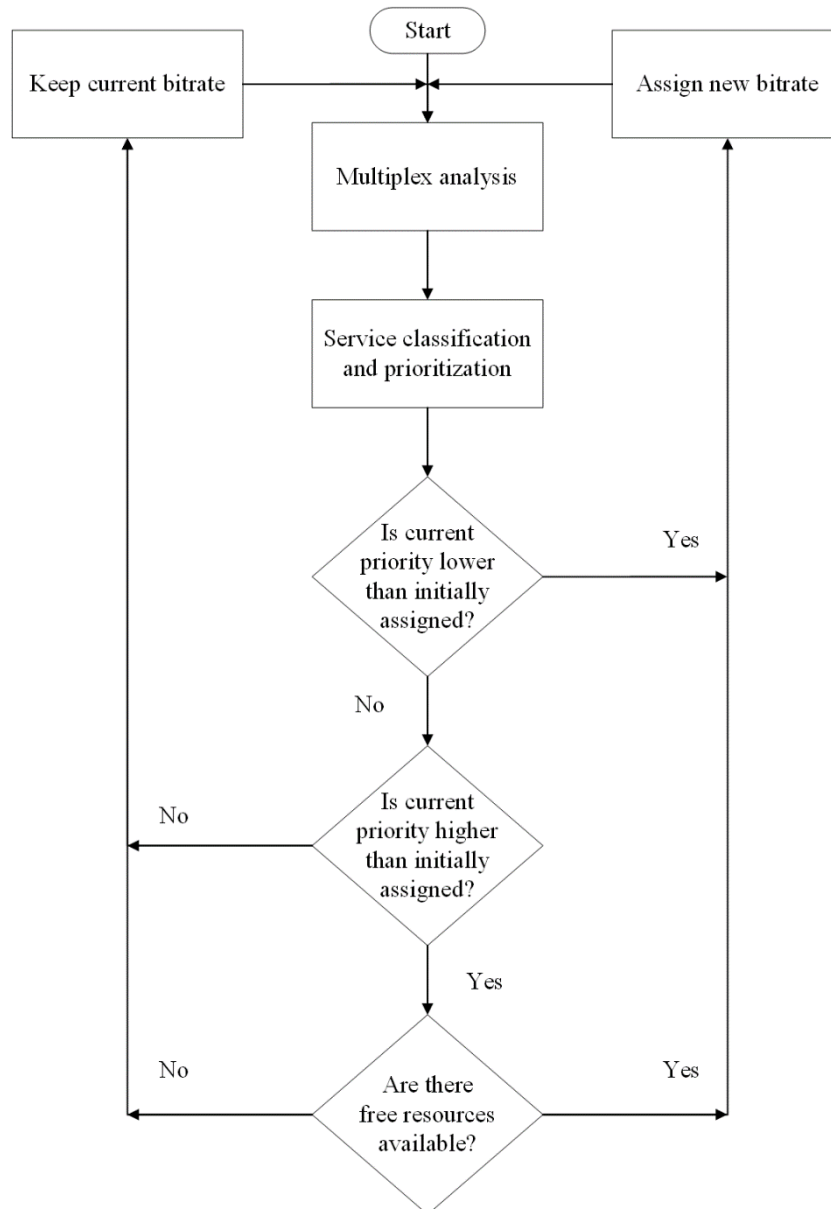

Fig. 4.1. The SMOC algorithm.

First, the algorithm performs an analysis of the multiplex, including the number and type of available services, and determines the initial priority. Secondly, all available services are classified and assigned with a new priority, depending on the content being transmitted.

Later on, the algorithm checks, whether the assigned priority is lower than the one initially specified, and assigns a new bitrate. If the current priority is the same as the initial one, the bitrate does not change. If the current priority is higher than the initial one it has to be checked, whether free multiplex resources are still available before assigning the new bitrate.

Currently, resources available in a single ensemble R_E include 864 CUs, which give a total of 1152 kbps to be divided among services (1 CU = 1.3(3) kbps), which are either allocated $R_{Allocated}$ or remain free R_{Free} , as defined in Form. (4.1):

$$R_E = \sum_{i=0}^{863} CU_i = \sum_{i=0}^k CU_i + \sum_{j=k+1}^{863} CU_j = R_{Allocated} + R_{Free}. \quad (4.1)$$

Allocated resources include those divided among audio R_{Audio} and data R_{Data} , as defined in Form. (4.2):

$$R_{Allocated} = R_{Audio} + R_{Data}. \quad (4.2)$$

The total number of available services N_S is the sum of A_i audio and D_j data services, as defined in Form. (4.3):

$$N_S = \sum_{i=1}^I A_i + \sum_{j=1}^J D_j = (A_1 + A_2 + \dots + A_I) + (D_1 + D_2 + \dots + D_J), \quad (4.3)$$

which means, that audio resources R_{Audio} are divided among I audio services, representing radio programs, as defined in Form. (4.4):

$$R_{Audio} = \sum_{i=1}^I R_{A_i} = R_{A_1} + R_{A_2} + \dots + R_{A_I}, \quad (4.4)$$

whereas data resources R_{Data} are divided among J data services, representing either program-dependent or program-independent data, as defined in Form. (4.5):

$$R_{Data} = \sum_{j=1}^J R_{D_j} = R_{D_1} + R_{D_2} + \dots + R_{D_J}, \quad (4.5)$$

The SMOC method applies only to managing resources that are divided among audio services. Data services remain untouched. In this case, the modified way of managing audio resources R'_{Audio} , assigned to particular radio programs, would be dependent on the assigned priority p_r , strictly connected with the type of transmitted content, as defined in Form. (4.6):

$$R'_{Audio} = \sum_{i=1}^I R_{A_i} p_r = R_{A_1} p_r + R_{A_2} p_r + \dots + R_{A_I} p_r, \quad (4.6)$$

where the current priority, from p_{r_1} (lowest priority) to p_{r_6} (highest priority), is an element of a set $p_r = \{p_{r_1}, p_{r_2}, p_{r_3}, p_{r_4}, p_{r_5}, p_{r_6}\}$, where $p_{r_1} < p_{r_2} < p_{r_3} < p_{r_4} < p_{r_5} < p_{r_6}$. This method would instruct the management segment of the DAB+ transmitting side on how to form the multiplex ensemble. Tab. 4.2 describes the relation between priority p_r and transmitted content.

Tab. 4.2. Relation between priority and transmitted content.

Priority	Assigned value	Transmitted content
p_{r_1}	1	Speech
p_{r_2}	2	Other
p_{r_3}	3	Commercial
p_{r_4}	4	Music Electronic
p_{r_5}	5	Music Popular
p_{r_6}	6	Music Classicist

According to [103], two subsequent reconfigurations must have a time distance of at least 6 s. Due to the fact, that there is no coordination required between service providers to agree on reconfiguration times, only the ensemble provider is entitled to define the instant of execution. Thereby, the latter is able to merge the requirements of several providers in such a way, that only execution times equal to or later than the requested ones are allocated. What is worth mentioning, only one reconfiguration can be pending at a time per provider.

Additionally, any changes in resource allocation for a particular radio program may be closely linked or even based on the time schedule of a specific radio program, e.g. *Talk Show* from 8 am to 10 am – set lower priority (assign less resources – lower bitrates), *Top 100 Music Chart* from 8 pm to 10 pm – set higher priority (assign more resources – higher bitrate).

It is worth mentioning, that for every digital terrestrial radio station, a detailed schedule is available many days in advance, just like an EPG in digital TV. The schedule may be found not only in the EPG of a particular station, but also on the broadcaster's official webpage.

4.1.1. Transmitted Audio Signals and Content Analysis

As noticed in previous studies, the audio content transmitted over different radio programs does vary, depending on the profile of a radio program, as well as time of the day, which is clearly visible in the time schedule of a particular broadcaster. The profile of a radio

program, as well as musical genres, are categories labeling pieces of music, which in broadcasting services refers to content transmitted over particular radio programs.

The characteristics of transmitted audio signals include factors such as instrumentation, rhythmic structure, pitch and harmonic content of the music itself [89]. In the broadcast chain, genres are used to manage large collections of music pieces, e.g. when forming the playlist or time schedule of a particular radio program.

Of course, this process is carried out manually by human experts. However, an automated way of managing and classifying content can provide an important component for a complete information retrieval system in a single multiplex. It can also help during the design and maintenance phase. For this reason, in case of each available DAB+ radio program, as described in Tab. 5.1, a period of 60 minutes has been recorded during primetime, that is between 9 am and 10 am. Primetime is viewed as the peak time, in which the biggest group of listeners consumes broadcast content. Therefore, it can be considered as the most challenging research scenario. Additionally, a 60 minute audio material for each radio program was recorded in random parts of the day for statistical purposes. The aim of this study was to investigate the relation between the profile of a radio program and the type of transmitted content.

Content analysis is a process based on feature extraction, carried out by computing a numerical representation that can be used to characterize a segment of an audio signal. The process of designing a set of descriptive features for a specific application is the main challenge in building any pattern recognition or classification systems. Once such features are extracted, an analysis may be carried out. Additional information on music genre classification may be found in [21][63].

This experiment was carried out in the MATLAB computing environment. The content classification was performed according to [92]. The block diagram of the content analyzer is shown in Fig. 4.2.

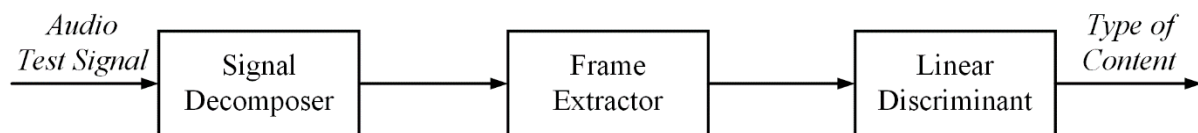

Fig. 4.2. Block diagram of the content analyzer.

Firstly, the input audio test signal was analyzed and the discriminatory features were extracted. These features, dependent on the domain of analysis and perceptual characteristics of the audio test signal, were based on the ATFT (*Adaptive Time-Frequency Transform*) transform.

In the ATFT algorithm, any signal $x(t)$ is decomposed into a linear combination of TF (*Time-Frequency*) functions $g_{\gamma_n}(t)$, selected from a redundant dictionary of TF functions [68]. In this case, redundant dictionary means that the dictionary is over-complete and contains much more than the minimum required basic functions, i.e. a collection of non-orthogonal basic functions that is larger than the minimum required basis functions to span the given signal space. With ATFT, a given signal $x(t)$ can be modeled as described in Form. (4.7):

$$x(t) = \sum_{n=0}^{\infty} a_n g_{\gamma_n}(t), \quad (4.7)$$

where $g_{\gamma_n}(t)$ is described in Form. (4.8) as:

$$g_{\gamma_n}(t) = \frac{1}{\sqrt{s_n}} g\left(\frac{t-p_n}{s_n}\right) e^{j(2\pi f_n t + \phi_n)}, \quad (4.8)$$

and a_n are the expansion coefficients. The scale factor s_n , also referred to as octave parameter, is used to control the width of the window function, whereas the p_n parameter controls the temporal placement. Parameters f_n and ϕ_n represent the frequency and phase of the exponential function. Index γ_n defines a particular combination of the TF decomposition parameters (s_n, p_n, f_n and ϕ_n).

The $x(t)$ signal is projected over a redundant dictionary of TF functions, with all possible combinations of scaling and translations. The dictionary of TF functions can be suitably modified or selected based on application. When the $x(t)$ signal is real and discrete, as in case of analyzed audio test samples, a dictionary of real and discrete TF functions is used.

In this case, the Gabor dictionary (Gaussian functions) was used [16]. At each iteration, the best correlated TF function was selected from this dictionary. The remaining signal, referred to as the residue, was further decomposed in the same way at each iteration subdividing them into TF functions. After N iterations, signal $x(t)$ can be expressed according to Form. (4.9) as:

$$x(t) = \sum_{n=0}^{N-1} \langle R^n x, g_{\gamma_n} \rangle g_{\gamma_n}(t) + R^N x(t), \quad (4.9)$$

where R is a set of functions. The first part represents the decomposed TF functions until N iterations, whereas the second part is the residue, which is decomposed in the subsequent iterations.

In this approach, only one TF decomposition parameter was used to generate a set of features from different frequency bands in order to perform a content classification. The recorded material for each individual radio program was sampled every minute over a period of 5 s.

In the decomposition process, the octave or scaling parameter was decided by the adaptive window duration of the Gaussian function that was used during the approximation of the local signal structures. Higher octaves corresponded to longer window durations, whereas lower octaves were linked to shorter window durations. The combination of these octaves represented the envelope of the signal. The envelope [85] of an individual audio signal provides information such as rhythmic structure and indirect pitch content [89], phonetic composition [72], as well as tonal and transient contributions. This analysis was performed in 3 frequency bands: 0-5, 5-10 and 10-20 kHz, since analyzing audio signals in sub-bands provides more precise information about their characteristics [1].

The content classification was carried out using LDA (*Linear Discriminant Analysis*). In the LDA analysis, the feature vector f_v was transformed into canonical function, as described in Form. (4.10):

$$f_v = \sum_{q=1}^Q u_q b_q + d = u_1 b_1 + u_2 b_2 + \dots + u_Q b_Q + d, \quad (4.10)$$

where q represents the number of features, $u = \{u_1, u_2, \dots, u_Q\}$ is the set of features, $b = \{b_1, b_2, \dots, b_Q\}$ is a set of coefficients, and d is constant. Based on previous research, the audio test signals have been divided into 6 groups: speech, music classicist, music popular, music electronic, other, commercial. The share of different types of content for all analyzed radio programs during primetime is described in Tab. 4.3, whereas results for each individual radio program are described in Fig. 4.3. The results of this mathematical analysis were validated by the author himself during a listening test.

Tab. 4.3. Share of different types of content – primetime.

No.	Profile	Share of content					
		Speech	M. Class.	M. Pop.	M. Elec.	Other	Comm.
1	Talk 1	45%	0%	37%	0%	5%	13%
2	Arts	45%	47%	0%	0%	8%	0%
3	Talk 2	33%	0%	47%	5%	7%	8%
4	Pop Music	0%	0%	18%	30%	43%	8%
5	Informative EN	90%	0%	0%	0%	10%	0%
6	Informative PL	100%	0%	0%	0%	0%	0%
7	Electronic Music	0%	0%	30%	58%	12%	0%
8	Regional	65%	0%	0%	0%	18%	17%
9	Children	3%	0%	3%	53%	40%	0%

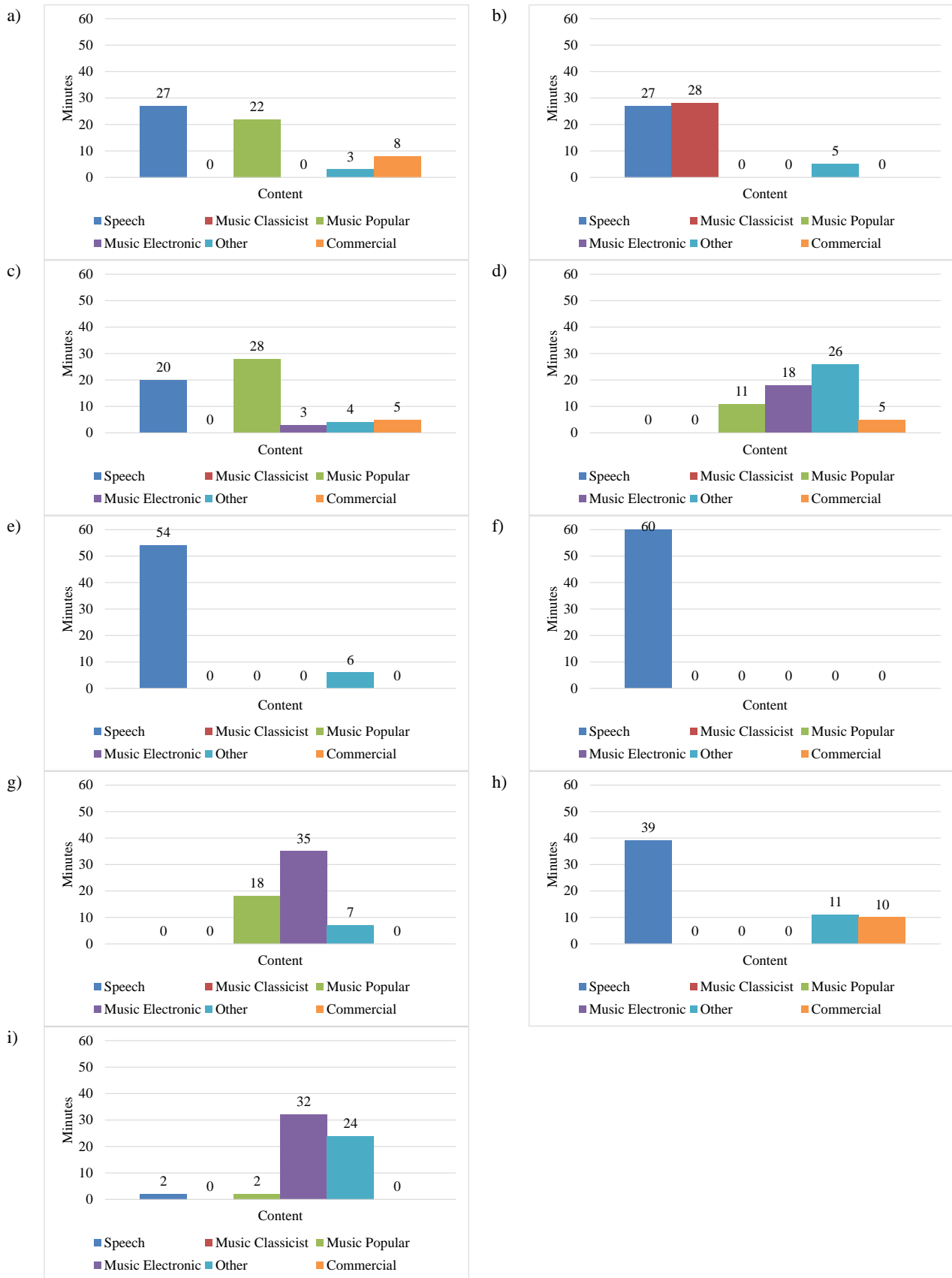

Fig. 4.3. Share of different types of content – primetime:

a) Talk 1, b) Arts, c) Talk 2, d) Pop Music, e) Informative EN, f) Informative PL, g) Electronic Music, h) Regional, i) Children.

According to obtained results, the type of content did vary and was strictly connected with the profile of the radio program. Generally speaking, in case of radio programs 1-3 and 9, the broadcasted material was a combination of speech, music, commercial and other signals. For programs 4 and 7, no speech signals were observed. Whereas in case of programs 5, 6 and 8, speech signals were dominant.

The share of different types of content for all analyzed radio programs during random parts of the day is described in Tab. 4.4, whereas results for each individual radio program are described in Fig. 4.4. The results of this mathematical analysis were validated by the author himself during a listening test.

Tab. 4.4. Share of different types of content – random parts of the day.

No.	Profile	Share of content					
		Speech	M. Class.	M. Pop.	M. Elec.	Other	Comm.
1	Talk 1	42%	53%	5%	0%	0%	0%
2	Arts	45%	55%	0%	0%	0%	0%
3	Talk 2	30%	0%	70%	0%	0%	0%
4	Pop Music	50%	0%	28%	22%	0%	0%
5	Informative EN	100%	0%	0%	0%	0%	0%
6	Informative PL	100%	0%	0%	0%	0%	0%
7	Electronic Music	12%	0%	43%	45%	0%	0%
8	Regional	48%	0%	52%	0%	0%	0%
9	Children	42%	0%	0%	0%	58%	0%

According to obtained results, the type of content did vary and was strictly connected with the profile of the radio program as well. Generally speaking, the variety of broadcasted content was smaller, and was limited only to 2 or 3 types of the audio material. Programs 6 and 7 were only composed of speech signals, regarding current news and affairs. As observed, besides program 2, the proportion of transmitted content for other radio programs was not the same as for primetime. Despite having a different profile, programs 1 and 2 had a similar share of content. Programs 4, 7 and 9 transmitted more speech signals, whereas program 8 had a larger share of music content. Surprisingly, in case of all 9 recorded radio programs, commercial content was not observed. This study formed the basis of introducing a new metric, that could adequately describe the profile of a radio program with respect to transmitted content.

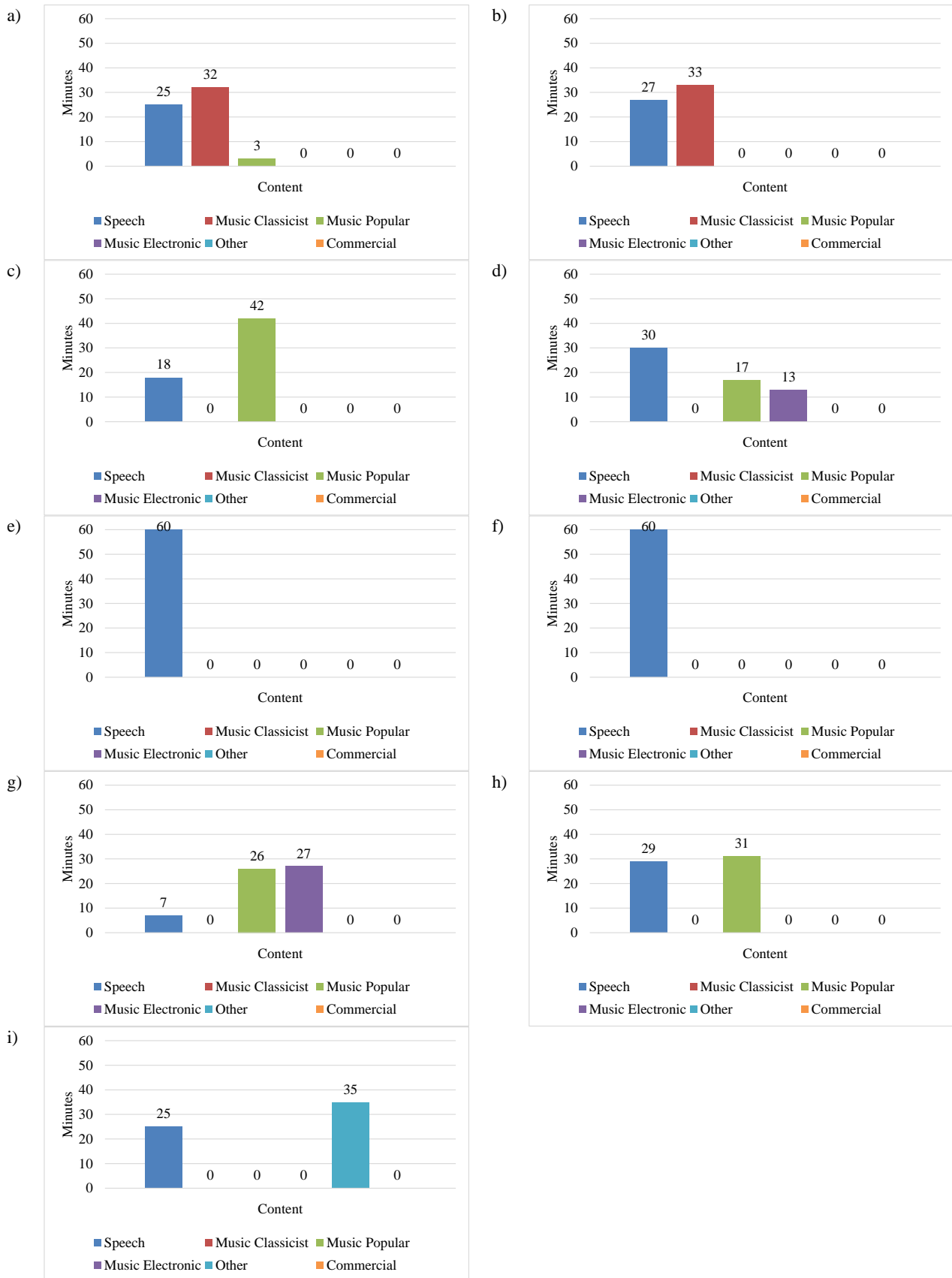

Fig. 4.4. Share of different types of content – random parts of the day:

a) Talk 1, b) Arts, c) Talk 2, d) Pop Music, e) Informative EN, f) Informative PL,
g) Electronic Music, h) Regional, i) Children.

4.1.2. The PCP Metric

Based on obtained results from the transmitted content analysis, a new metric has been developed, called PCP (*Program Content Profile*), which can be used to describe the profile of a radio program based on transmitted content. The PCP coefficient is defined in Form. (4.11) as:

$$PCP = x_A \cdot S + x_B \cdot M_C + x_C \cdot M_P + x_D \cdot M_E + x_E \cdot O + x_F \cdot C, \quad (4.11)$$

where x_A – weight for speech content, S – share of speech content, x_B – weight for classicist music content, M_C – share of classicist music content, x_C – weight for popular music content, M_P – share of popular music content, x_D – weight for electronic music content, M_E – share of electronic music content, x_E – weight for other content, O – share of other content, x_F – weight for commercial content, C – share of commercial content.

The share of different types of content is defined as a percentage in the analyzed time period. Weights x_A to x_F are defined as described in Tab. 4.5.

Tab. 4.5. Relation between weight and type of content.

Content		Weight
Speech		1
Other		2
Commercial		3
Music	Electronic	4
	Popular	5
	Classicist	6

The PCP coefficient, obtained for all 9 analyzed radio programs during primetime, is described in Tab. 4.6, whereas the coefficient obtained for radio programs recorded at random parts of the day, is described in Tab. 4.7. The comparison of calculated PCPs for radio programs, recorded both during primetime and random parts of the day, is described in Fig. 4.5.

In the ideal situation, the PCP coefficient of each radio program should be an integer, as for informative radio programs. This means, that the profile of a particular radio program adequately resembles the type and percentage of transmitted content. When the broadcasted material is a combination of different types of content, the PCP coefficient should be approximated to the nearest result, for further analysis.

Tab. 4.6. PCP coefficient with respect to profile – primetime.

Profile	PCP
Talk 1	2.28
Arts	2.95
Talk 2	2.65
Pop Music	2.67
Informative EN	1.10
Informative PL	1.00
Electronic Music	3.18
Regional	1.35
Children	2.57

Tab. 4.7. PCP coefficient with respect to profile – random parts of the day.

Profile	PCP
Talk 1	3.87
Arts	3.75
Talk 2	3.80
Pop Music	2.78
Informative EN	1.00
Informative PL	1.00
Electronic Music	4.08
Regional	3.07
Children	1.58

The proposed *PCP* coefficient can be utilized to describe the profile of a radio program, especially when designing a schedule of a service in the ensemble. It can be regarded as an adequate way to describe the audio service transmitting different types of content.

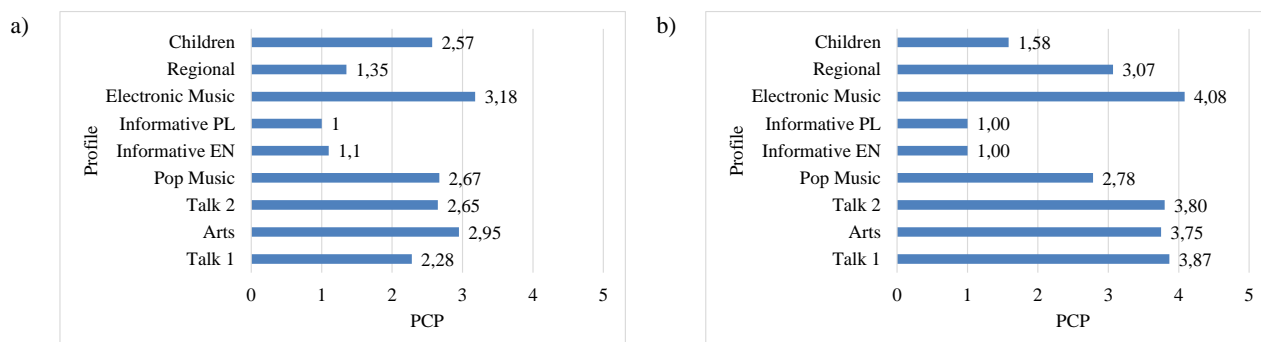

Fig. 4.5. PCP coefficient with respect to profile:

a) primetime, b) random parts of the day.

Additionally, when analyzing periodical radio programs, the *PCP* coefficient for *Radio Chopin* and *Radio Gwiazdka* was equal to 6 and 5, respectively.

What is worth mentioning, the share of transmitted audio content and the profile of a radio program may change in the nearest future, depending on the needs, expectations and music taste of the listener. Broadcasters do not only focus on providing high quality services to the user using the best possible delivery means. The economic aspect, associated with the number of listeners and related revenue from advertisement, is also a crucial factor. That is why any resource savings in a single multiplex frequency block would be most welcomed.

4.2. Adaptive SMOC Multiplexing Simulator

The preliminary analysis showed, that a fixed bitrate assignment does not guarantee efficient multiplex resource management. The type of content transmitted over different programs does vary, depending on the profile of the radio program, as well as time of the day. Radio programs consist of different types of content, which is clearly visible in the schedule of particular broadcasters. That is why a multiplexing simulator has been designed. The block diagram of the SMOC adaptive multiplexing simulator is shown in Fig. 4.6.

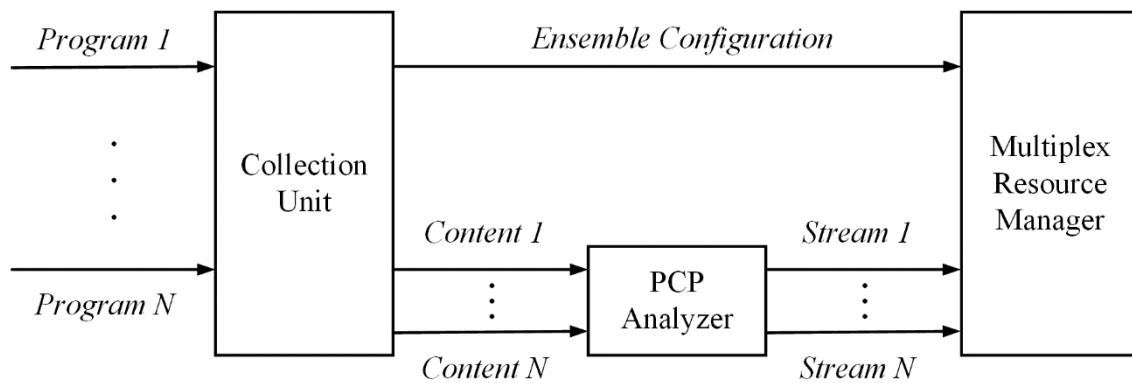

Fig. 4.6. Block diagram of the SMOC adaptive multiplexing simulator.

All radio programs, in the form of WAV files with additional text data describing the profile of each particular radio program and initially assigned resources, first enter the *Collection Unit*. This unit determines the number of available services in a single ensemble and related features. It outputs the ensemble configuration, as well as content for each individual radio program.

Next, the content is processed by the *PCP Analyzer*, which performs an analysis of the type of transmitted content over particular services. The analysis is performed every minute over a period of 5 s. Based on this, it calculates the *PCP* metric for each individual radio

program and outputs the stream with a new bitrate, according to the priority assigned for a particular type of content.

Later on, the ensemble configuration, along with the stream for each individual service, is processed by the *Multiplex Resource Manager*. This block is responsible for the adaptive multiplexing, carried out according to the SMOC method. It manages the resources available in a single ensemble and determines whether a portion of resources can be saved in case of particular radio programs and utilized for other radio programs. It also determines the efficiency of resource management in an adaptive multiplexing scenario.

4.2.1. Test Scenario

In order to test the efficiency of the proposed SMOC method, a simulator has been developed. This study was carried out in the MATLAB computing environment, based on a set of recorded signals samples during both primetime and random parts of the day. The simulated multiplex ensemble configurations included:

1. MUX 1 – multiplex consisting of 9 programs – an ensemble including music programs; profile: *Arts, Pop Music, Electronic Music*, 3 of each kind.
2. MUX 2 – multiplex consisting of 12 programs – an ensemble including various programs; profile: *Informative, Talk, Regional, Children*, 3 of each kind.
3. MUX 3 – multiplex consisting of 8 programs – an ensemble including programs of the national broadcaster simulcasted in FM; profile: *Arts, Talk 1, Talk 2, Pop Music*; 2 of each kind.
4. MUX 4 – multiplex consisting of 9 programs – resembling the ensemble configuration of the national broadcaster.

The share and time distribution of different types of content, with respect to the profile of a particular radio program during either primetime or random parts of the day, were assigned according to the PCP coefficient. The basic parameters of the analyzed multiplex configurations for primetime and random parts of the day are described in Tab. 4.8. The study was performed in either a primetime (PCP primetime) or random parts of the day (PCP random) scenario.

Tab. 4.8. Basic parameters of the simulated multiplexes.

Multiplex	Resources [kbps]		Service	Profile	PCP primetime	PCP random	Initial bitrate [kbps]
	Allocated	Free					
MUX 1	1008	144	Program 1	Arts	2.95	3.75	128
			Program 2	Arts	2.95	3.75	128
			Program 3	Arts	2.95	3.75	128
			Program 4	Pop Music	2.67	2.78	112
			Program 5	Pop Music	2.67	2.78	112
			Program 6	Pop Music	2.67	2.78	112
			Program 7	Electronic Music	3.18	4.08	96
			Program 8	Electronic Music	3.18	4.08	96
			Program 9	Electronic Music	3.18	4.08	96
MUX 2	1056	96	Program 1	Informative EN	1.10	1.00	64
			Program 2	Informative EN	1.10	1.00	64
			Program 3	Informative PL	1.00	1.00	64
			Program 4	Talk 1	2.28	3.87	112
			Program 5	Talk 2	2.65	3.80	112
			Program 6	Talk 2	2.65	3.80	112
			Program 7	Regional	1.35	3.07	104
			Program 8	Regional	1.35	3.07	104
			Program 9	Regional	1.35	3.07	104
			Program 10	Children	2.57	1.58	72
			Program 11	Children	2.57	1.58	72
			Program 12	Children	2.57	1.58	72
MUX 3	928	224	Program 1	Arts	2.95	3.75	128
			Program 2	Arts	2.95	3.75	128
			Program 3	Talk 1	2.28	3.87	112
			Program 4	Talk 1	2.28	3.87	112
			Program 5	Talk 2	2.65	3.80	112
			Program 6	Talk 2	2.65	3.80	112
			Program 7	Pop Music	2.67	2.78	112
			Program 8	Pop Music	2.67	2.78	112
MUX 4	864	288	Program 1	Talk 1	2.28	3.87	112
			Program 2	Arts	2.95	3.75	128

			Program 3	Talk 2	2.65	3.80	112
			Program 4	Pop Music	2.67	2.78	112
			Program 5	Informative EN	1.10	1.00	64
			Program 6	Informative PL	1.00	1.00	64
			Program 7	Electronic Music	3.18	4.08	96
			Program 8	Regional	1.35	3.07	104
			Program 9	Children	2.57	1.58	72

All configurations had a small amount of free resources, taking into consideration that every ensemble has a *Data*, *Journaline*, or other services that transmit only data components. Furthermore, any spare portion of resources could be used to transmit a periodical program, as it was in case of *Radio Chopin* or *Radio Gwiazdka*.

4.2.2. Multiplex Resource Management

The results of this simulation, for each of the 4 multiplex ensemble configurations for primetime, are shown in Fig. 4.7. A detailed analysis for MUX 4 multiplex configuration, which resembles the ensemble of the national broadcaster, including each individual radio program, is shown in Fig. 4.8.

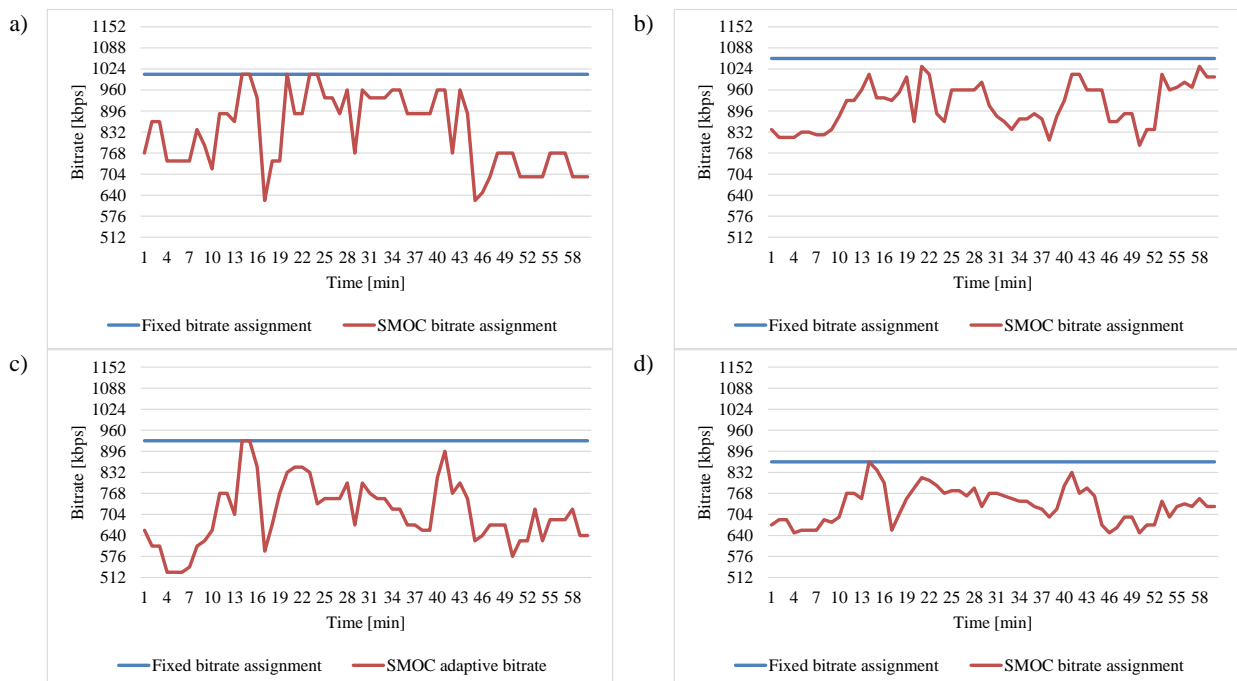

Fig. 4.7. Multiplex resource management – primetime:

a) MUX 1, b) MUX 2, c) MUX 3, d) MUX 4.

In case of MUX 1, resources assigned in an adaptive way would exceed resources assigned in a fixed manner in 2 time periods, of 2 minutes each, that is in minutes 14-15 and 23-24. The SMOC method has a control mechanism, based on prioritization, that prevents this from happening. In order not to exceed the level of resources assigned in a fixed manner, resources assigned for specific radio programs, based on profile and transmitted content, would have to be lowered.

This multiplex ensemble configuration includes only musical radio programs, playing classicist, popular and electronic music. The priority assigned for electronic music is the lowest, so despite transmitting popular music content in those 2 mentioned time periods, the assigned bitrate would be set to 96 kbps, instead of 112 kbps, which is the initial bitrate assigned for radio programs of an electronic music profile. As described in Chapter 3, the perceived difference observed for this type of content, processed at both bitrates, would not lead to a significant decrease in quality. This indicates, that such a mechanism is justified.

For MUX 2, in the whole 60 minute time period, adaptive multiplexing would provide resource savings, as the fixed bitrate assignment level was not exceeded. This means, that such a configuration could enable to introduce additional audio or data services.

In the MUX 3 configuration, adaptive bitrate assignment did match the fixed bitrate assignment line in a single 2 minute period. The resources allocated in a fixed manner were not exceeded. In this configuration, a significant amount of resources could be saved.

The MUX 4 configuration, resembling the ensemble of the national broadcaster including 9 radio programs, also proved to be sufficient for adaptive multiplexing. With the use of the SMOC method, the required bitrate could be lowered as well.

As shown in the 3 latter configurations, the adaptive multiplexing method enables to deliver content perceived as of high quality without exceeding the fixed bitrate assignment level. This would lead to an increase in multiplex resource management in a single 1.5 MHz frequency block. Any portion of saved resources could not only increase the quality of currently offered services, but introduce yet another audio or data service, including periodical ones.

According to obtained results, as shown in Fig. 4.8, in case of programs a) – d) and g) – i), adaptive bitrate assignment would be most preferable. Due to divers transmitted content, the SMOC method would lead to more efficient multiplex resource management. For programs e) – f), a fixed bitrate assignment method seems sufficient.

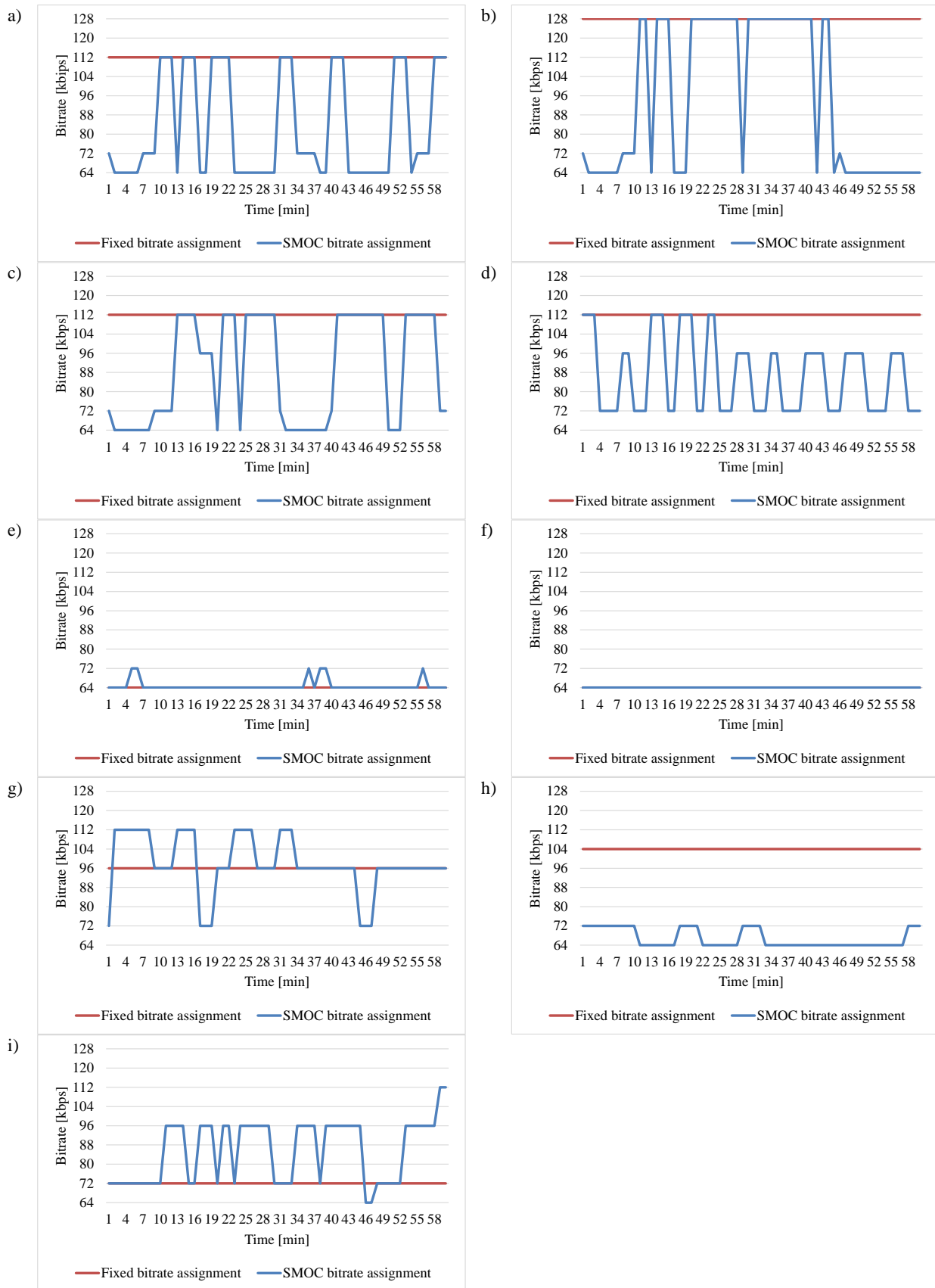

Fig. 4.8. Radio program resource management – primetime:

- a) Talk 1, b) Arts, c) Talk 2, d) Pop Music, e) Informative EN, f) Informative PL,
g) Electronic Music, h) Regional, i) Children.

The results of this simulation, for each of the 4 multiplex ensemble configurations for random parts of the day, are shown in Fig. 4.9. A detailed analysis for MUX 4 multiplex configuration, which resembles the ensemble of the national broadcaster, including each individual radio program, is shown in Fig. 4.10.

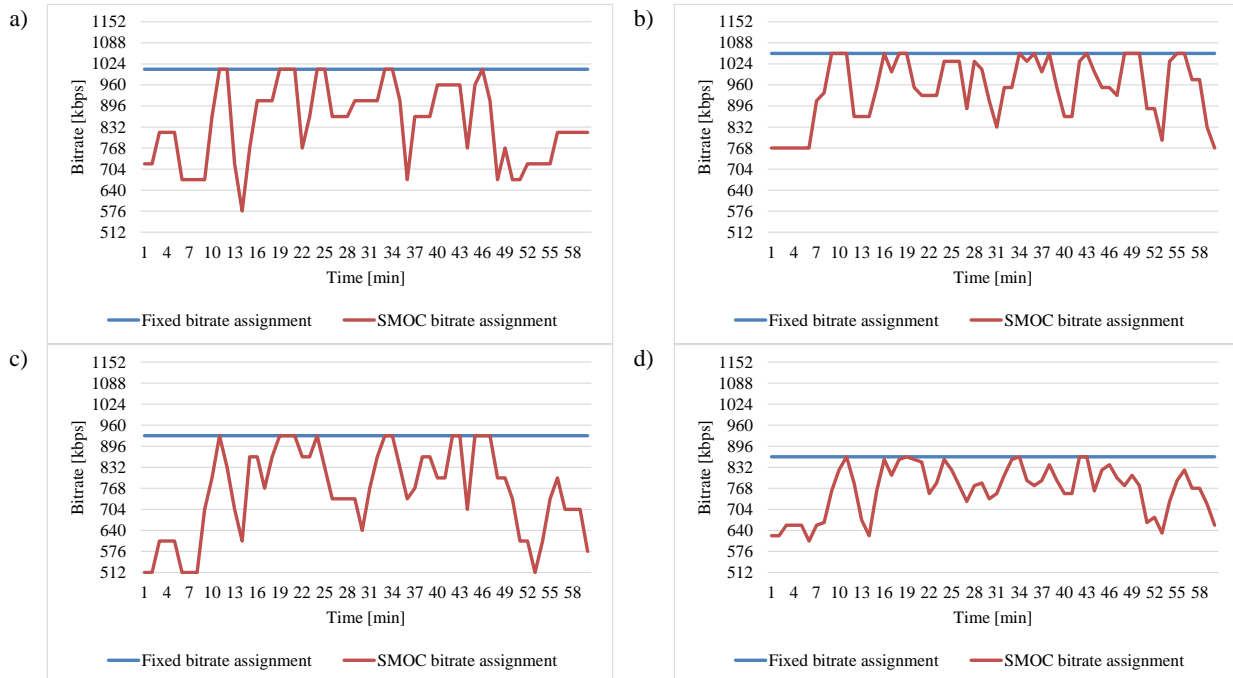

Fig. 4.9. Multiplex resource management – random parts of the day:

a) MUX 1, b) MUX 2, c) MUX 3, d) MUX 4.

In the random parts of the day scenario, resources assigned in an adaptive manner would exceed those assigned in a fixed way in more time periods. This is caused by the fact, that the schedule is not time-aligned. Furthermore, introducing an adaptive multiplexing method forces joint actions of particular broadcasters offering services in a single ensemble, i.e. during the reconfiguration process itself. As an effect, a further increase in quality or an introduction of additional audio or data services would be less available than in case of the primetime scenario. However, as in the primetime scenario, the maximum available bitrate, equal to 1152 kbps, was never exceeded.

In case of MUX 1, resources assigned in an adaptive way would exceed resources assigned in a fixed manner in 3 time periods, that is in minutes 11-12, 19-21 and 33-34. In order to prevent that from happening, since the priority assigned for electronic music is the lowest, the assigned bitrate for programs of an electronic music profile would be set to 96 kbps, instead of 112 kbps when popular music pieces are broadcasted.

When it comes to MUX 2, the security mechanisms related with prioritization would have to be applied in time periods 9-11, 16, 18-19, 24, 34, 36, 38, 42-43, 48-50, 55-56. During this time, informative services are transmitting only speech signals, whereas the program dedicated to children transmits only speech and other signals. Neither of them exceeds the level of fixed assigned resources. The same remarks relate to *Talk 2* radio programs, which do not require more than 112 kbps. In case of the regional program, the bitrate is lowered to the initial 104 kbps. For the *Talk 1* radio program, the bitrate is lowered to the initial 112 kbps in the mentioned periods as well, except for the 9-11 time period.

For MUX 3, the prioritization control mechanism was applied in 4 time periods, that is 19-21, 24, 33-34 and 46-47. During this time, the bitrate for *Talk 1* radio programs was set to 112 kbps, despite delivering classicist music content, resembling the initial bitrate assigned for programs with this profile.

In case of MUX 4, security mechanisms were utilized only in five 1-minute time periods: 11, 19, 24, 34 and 43. The bitrate for regional programs would be set to the initial 104 kbps during all 5 time periods, whereas in case of the program dedicated to electronic music, the bitrate would be set to the initial 96 kbps in periods 11, 19 and 34. Whereas, for *Talk 1* radio programs, the bitrate would be set to the initial 112 kbps in periods 19, 24 and 34.

As described in Chapter 3, the perceived difference observed for this types of content, processed at given bitrates, would not lead to a significant decrease in quality. Additionally, a spare portion of saved resources can be observed in each out of 4 multiplex configurations. It is worth mentioning, that listeners would welcome any additional audio or data services, e.g. traffic information or weather forecasts.

According to obtained results, as shown in Fig. 4.10, once again in case of radio programs e) – f), a fixed bitrate assignment method seems sufficient. Both fixed and adaptive bitrate assignment plots match one another. Similarly as before, when it comes to programs a) – d) and g) – i), adaptive bitrate assignment would be most preferable. The type of broadcasted content is different than during primetime, which is clearly visible in the character of the plots. In this case, the fixed bitrate assignment level was exceeded in 3 out of 9 cases, similarly to the primetime scenario.

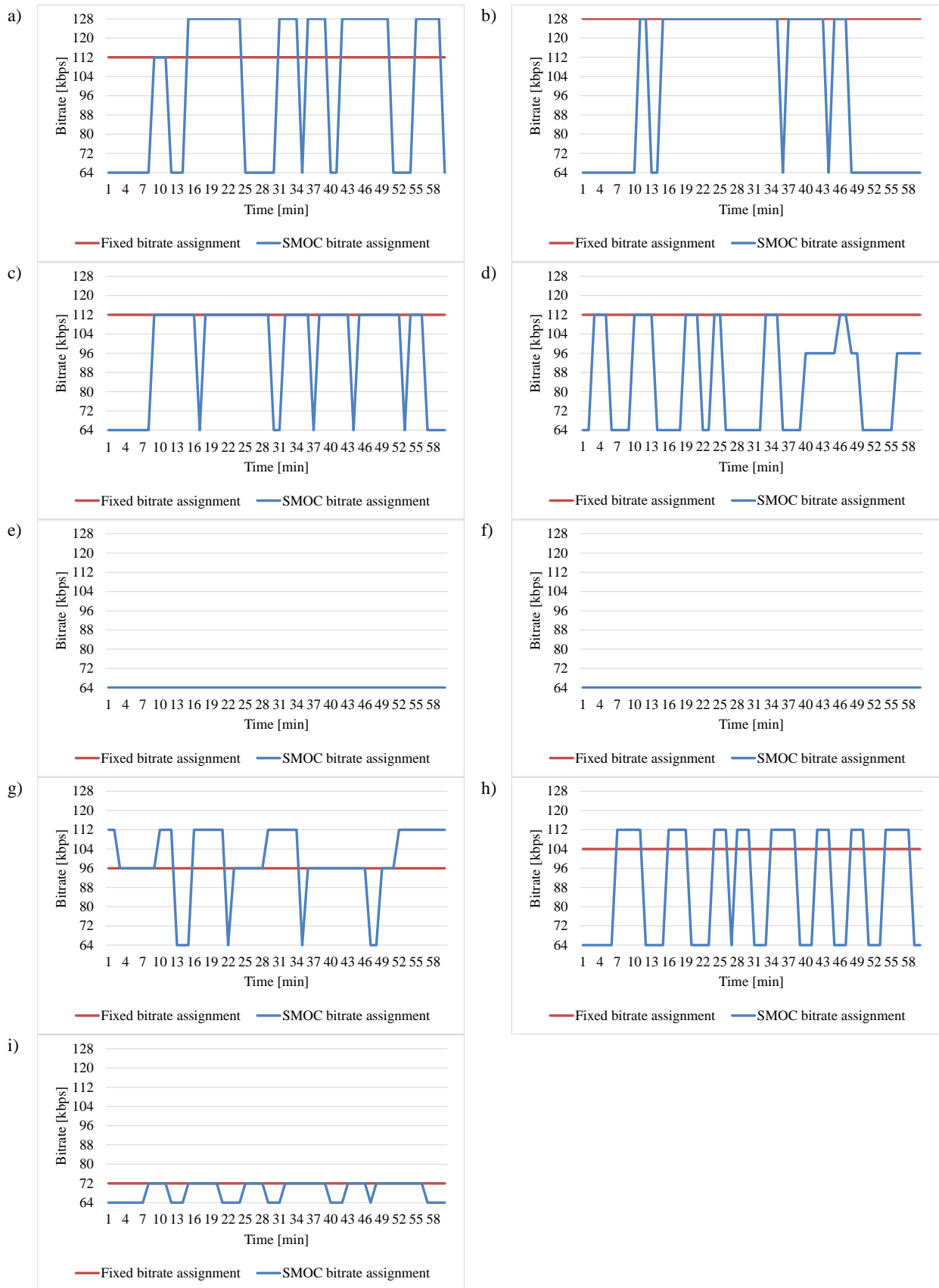

Fig. 4.10. Radio program resource management – random parts of the day:

a) Talk 1, b) Arts, c) Talk 2, d) Pop Music, e) Informative EN, f) Informative PL,
g) Electronic Music, h) Regional, i) Children.

What is worth mentioning, the SMOC method enables to determine which radio program, based on priorities assigned to different types of content, can or cannot exceed the initially assigned fixed bitrate. By simply determining the character of currently transmitted audio signals over particular services, content with higher priority is preferred over content with lower priority.

In this research scenario, a spare portion of resources remained unoccupied, in order to assign them among particular services when needed. This approach seemed justifiable, since eventually from time to time, additional pop-up services appear in the ensemble, which transmit content only for a short period of time. Some of them can relate to periodical events, whereas other may be linked with unexpected events. Instead of designing the ensemble all over again, an adaptive bitrate assignment method would enable to reconfigure the ensemble in a precise, elegant and effective way. However, clear and transparent regulations are required, especially among parties and broadcasters which are engaged in a single multiplex ensemble.

4.2.3. The MCF Metric

The SMOC method enables to reduce the level of required multiplex resources, as defined in Form. (4.12):

$$R_{SMOC} = R_{Fixed} - R_{Saved}, \quad (4.12)$$

where R_{SMOC} is the required amount of resources according to the SMOC method, R_{Fixed} is the amount of resources required in a fixed bitrate assignment, and R_{Saved} represents the averaged saved resources over a predefined time period.

In this case, the length of the analyzed period L was equal to 60. Based on this, the amount of saved resources R_{Saved} can be calculated, as defined in Form. (4.13):

$$R_{Saved} = \sum_{t=1}^L \frac{R_{S_t}}{L}, \quad (4.13)$$

where R_{S_t} is the amount of saved resources in period t . The results, including multiplex resource saving for each of the 4 configurations in the primetime scenario, are shown in Tab. 4.9.

In each case, the use of an adaptive bitrate assignment and resource allocation method would lead to multiplex resource savings, on an average level of more than 128 kbps. In case of the national broadcaster, the share of averaged saved resources is equal to 131 kbps, which gives a total of 15% of allocated multiplex resources. The biggest savings can be observed for

the MUX 3 configuration, where the SMOC method could lower the required resources by nearly a quarter.

Tab. 4.9. Multiplex resource savings – primetime.

Multiplex	Resources [kbps]		Resource savings
	Allocated R_{Fixed}	Avg. saved R_{Saved}	
MUX 1	1008	174	17%
MUX 2	1056	143	14%
MUX 3	928	221	24%
MUX 4	864	131	15%

The results, including multiplex resource saving for each of the 4 configurations in the random parts of the day scenario, are shown in Tab. 4.10.

Tab. 4.10. Multiplex resource savings – random parts of the day.

Multiplex	Resources [kbps]		Resource savings
	Allocated R_{Fixed}	Avg. saved R_{Saved}	
MUX 1	1008	159	16%
MUX 2	1056	96	9%
MUX 3	928	164	18%
MUX 4	864	97	11%

As shown, in this scenario, resource savings for each out of 4 multiplex configurations was smaller, compared to primetime. In a non-time-aligned action, resource savings in a single multiplex ensemble ranged from 9% till 18 %, compared to 15% till 24%. This clearly indicates, that any actions regarding an introduction of an adaptive bitrate assignment and resource allocation method should be performed in a timely manner as a synchronized action between all broadcasters transmitting radio programs in a single ensemble. The comparison of multiplex resource savings for both primetime and random parts of the day scenarios is shown in Fig. 4.11.

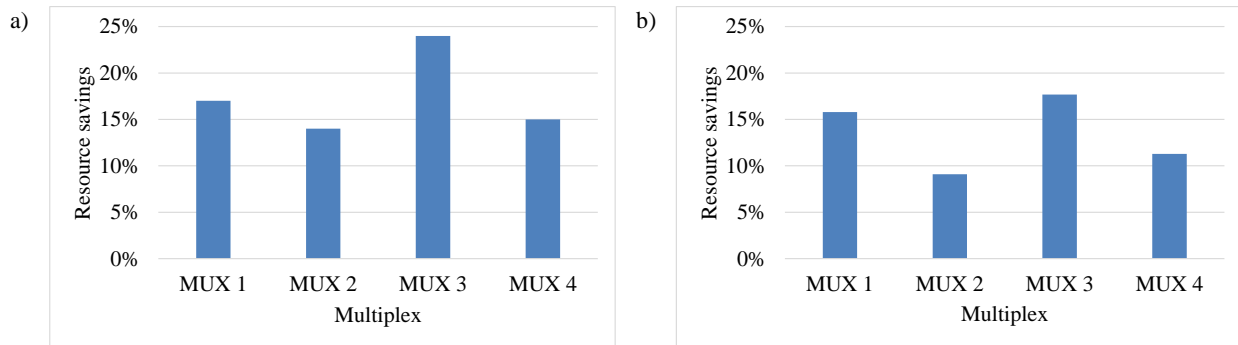

Fig. 4.11. Multiplex resource savings:
a) primetime, b) random parts of the day.

Introducing the SMOC method would lead to high multiplex resource savings, since in most cases, the adaptive bitrate assignment does not exceed the initially assigned fixed level. Any resource savings could be utilized to increase the quality of currently broadcasted material or introduce another radio program, e.g. a periodical one, including transmissions from sport or cultural events.

The SMOC adaptive multiplexing method enables to provide multiplex resource savings, compared with a fixed bitrate assignment method. These savings could be expressed by the *MCF* (*Multiplex Content Factor*) metric, as described in Form. (4.14), which can be used to describe the efficiency of multiplex resource management:

$$MCF = \frac{R_{SMOC}}{R_{Fixed}}. \quad (4.14)$$

Tab. 4.11 and Fig. 4.12 describe the *MCF* coefficient for all 4 multiplex configurations. The *MCF* coefficient describes how efficient is the management of multiplex resources. The lower the value, the more resources are saved.

Tab. 4.11. *MCF* coefficient.

<i>Multiplex</i>	<i>MCF</i> <i>primetime</i>	<i>MCF</i> <i>random</i>
MUX 1	0.83	0.84
MUX 2	0.86	0.91
MUX 3	0.76	0.82
MUX 4	0.85	0.89

Any saved resources could be used to either increase the quality of currently offered services or introduce yet another full-time, part-time or periodical program.

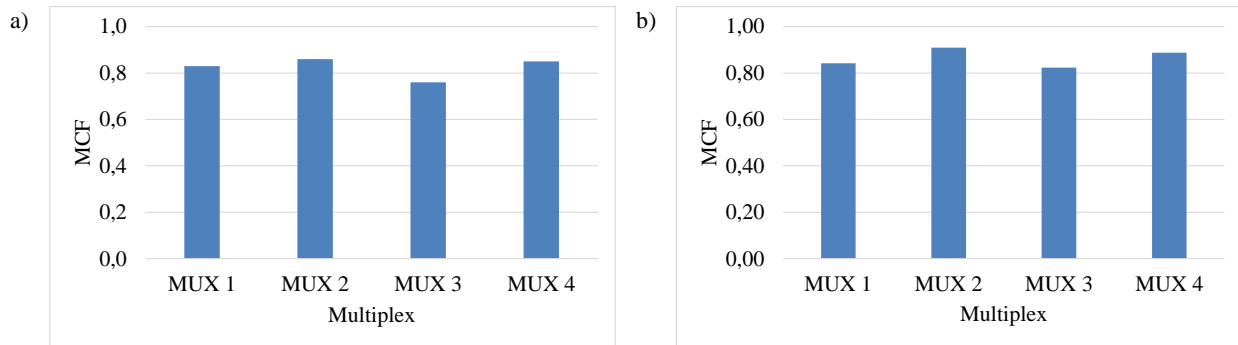

Fig. 4.12. MCF coefficient:

a) primetime, b) random parts of the day.

This metric could be used to rank the efficiency of multiplex resource management on both national and regional levels, during the planning and maintenance phase. Moreover, it could be utilized to determine the chances of introducing additional audio or data services.

4.2.4. Introducing Additional Audio or Data Services

Based on a set of gathered samples, a probability analysis had been carried out, concerning the introduction of additional audio or data services. The probability of introducing additional services P_A is defined in Form. (4.15) as:

$$P_A = \sum_{t=1}^L \frac{R_{P_t}}{L}, \quad (4.15)$$

where the probability of saving enough resources in period t $R_{P_t} = \begin{cases} 1 & \text{for } R_{P_t} \geq R_Q \\ 0 & \text{for } R_{P_t} < R_Q \end{cases}$.

The required resources R_Q , from R_{Q_1} (lowest required resources) to R_{Q_6} (highest required resources), is an element of a set $R_Q = \{R_{Q_1}, R_{Q_2}, R_{Q_3}, R_{Q_4}, R_{Q_5}, R_{Q_6}\}$, where $R_{Q_1} < R_{Q_2} < R_{Q_3} < R_{Q_4} < R_{Q_5} < R_{Q_6}$. Tab. 4.12 describes the relation between required resources R_Q and type of service.

When it comes to multiplex ensemble management, related with introducing additional audio and data services, content providers may deliver dependent or independent services. These services would be dependent upon regulations and individual contracts between the broadcaster and regulator.

Tab. 4.12. Relation between required resources and type of service.

Type of service	Required resources	Required bitrate [kbps]
Data	R_{Q_1}	16
Audio lower quality	R_{Q_2}	64
	R_{Q_3}	72
Audio higher quality	R_{Q_4}	96
	R_{Q_5}	112
	R_{Q_6}	128

Results of this statistical analysis, for all 4 analyzed multiplex ensemble configurations in the primetime scenario, are described in Tab. 4.13, whereas results for each individual radio program are shown in Fig. 4.13. Results for the random part of the day scenario are provided in Tab. 4.14 and Fig. 4.14.

Tab. 4.13. Probability of introducing additional services – primetime.

Multiplex	Probability					
	16 [kbps]	64 [kbps]	72 [kbps]	96 [kbps]	112 [kbps]	128 [kbps]
MUX 1	0.92	0.80	0.80	0.70	0.70	0.53
MUX 2	1.00	0.83	0.83	0.77	0.60	0.57
MUX 3	0.97	0.95	0.95	0.90	0.87	0.85
MUX 4	0.98	0.92	0.90	0.78	0.63	0.52

Tab. 4.14. Probability of introducing additional services – random parts of the day.

Multiplex	Probability					
	16 [kbps]	64 [kbps]	72 [kbps]	96 [kbps]	112 [kbps]	128 [kbps]
MUX 1	0.83	0.75	0.75	0.75	0.60	0.60
MUX 2	0.72	0.57	0.57	0.53	0.42	0.40
MUX 3	0.80	0.80	0.67	0.67	0.62	0.62
MUX 4	0.83	0.67	0.65	0.45	0.37	0.30

According to obtained results, the SMOC adaptive bitrate assignment and resource allocation method enables to introduce additional audio or data services in all 4 analyzed multiplex ensemble configurations.

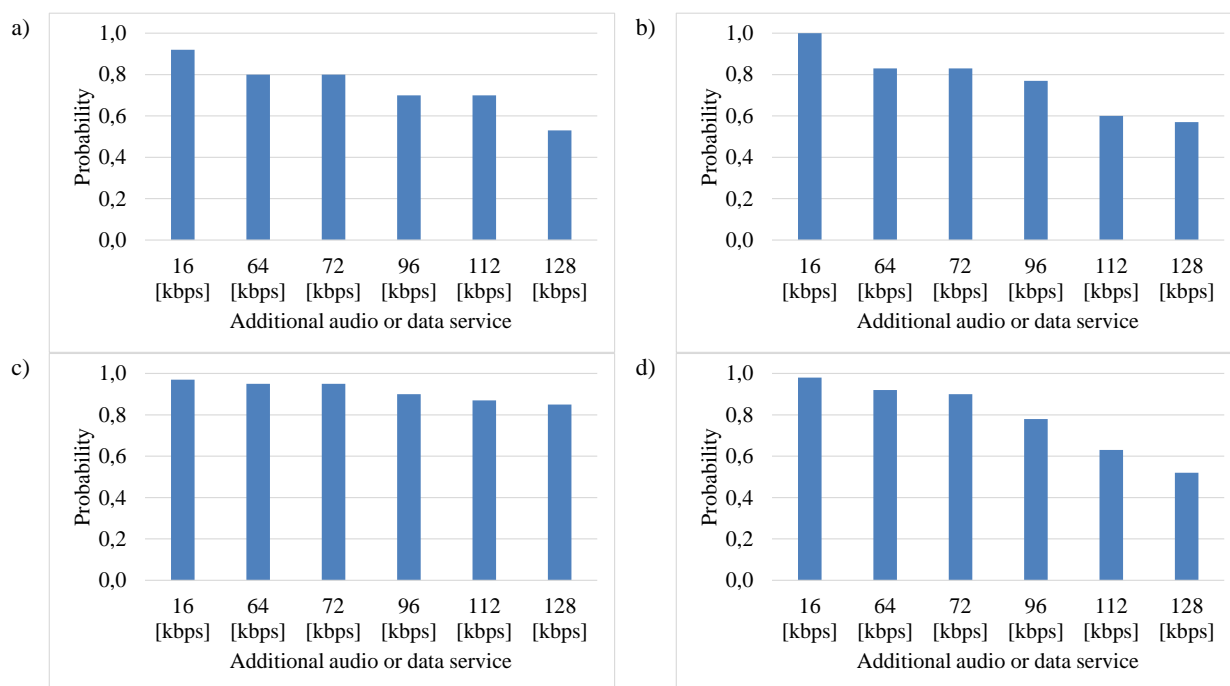

Fig. 4.13. Probability of introducing additional services – primetime:

a) MUX 1, b) MUX 2, c) MUX 3, d) MUX 4.

For MUX 1, data services at 16 kbps would be available with probability 0.92, whereas audio services of lower bitrates, that is 64 – 72 kbps, would be available for 48 minutes and more. Higher quality audio services, between 96 – 128 kbps, would be available for more than 30 minutes in every 60 minute time period.

The MUX 2 ensemble configuration would enable a continuous data transmission at 16 kbps during a full 60 minute time period. Lower quality audio services between 64 – 72 kbps would be available for more than three quarters of an hour. Higher quality audio services, offering content at 96 – 128 kbps, would be available for more than 30 minutes.

When it comes to MUX 3, this ensemble configuration would provide the listener with additional services with probability 0.8 and more, that is more than 45 minutes in a 60 minute time period, regardless of chosen bitrate.

In case of MUX 4, an additional 16 kbps data program would be available with probability 0.98 over a 60 minute time period. Whereas, an audio program broadcasted at lower bitrates would be available with probability of 0.90 and higher (54 minutes and more). Services of higher bitrates would be available during a period of 30 minutes and more.



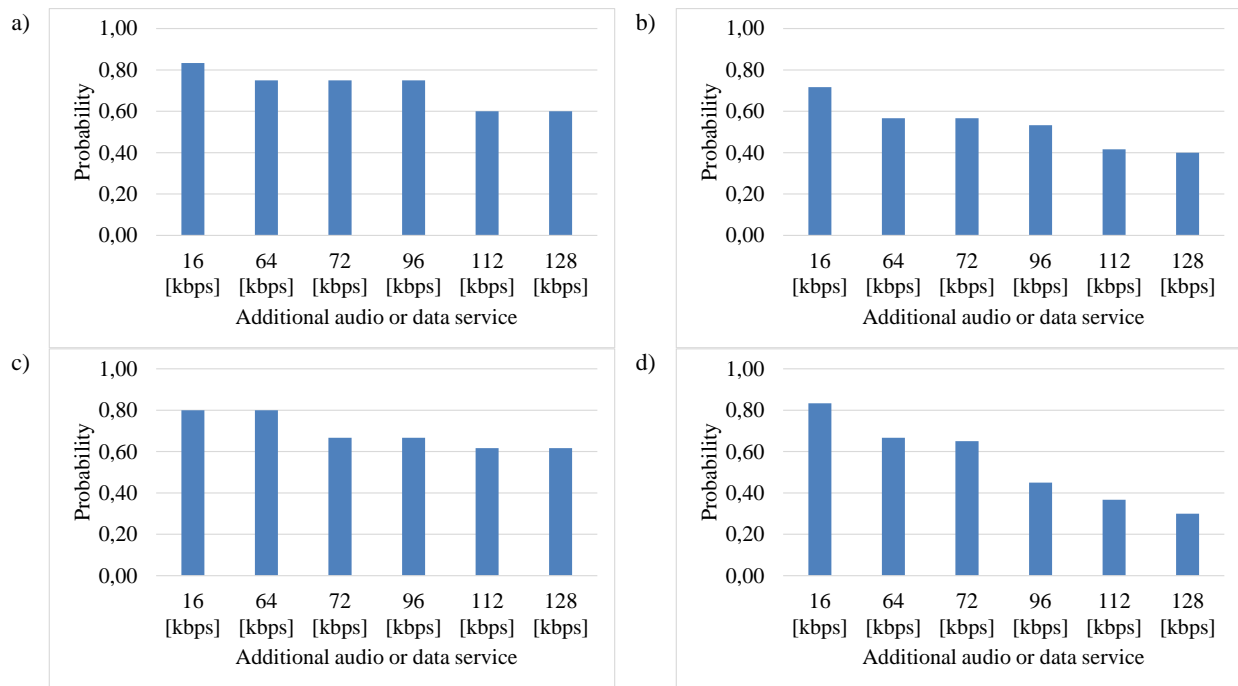

Fig. 4.14. Probability of introducing additional services – random parts of the day:

a) MUX 1, b) MUX 2, c) MUX 3, d) MUX 4.

For MUX 1, data services at 16 kbps would be available with probability 0.83, whereas audio services of lower bitrates, that is 64 – 72 kbps, would be available for 45 minutes. Higher quality audio services, between 96 – 128 kbps, would be available for more than 30 minutes in every 60 minute time period.

The MUX 2 ensemble configuration would enable a continuous data transmission at 16 kbps during three quarters of an hour. Lower quality audio services between 64 – 72 kbps would be available for more than 30 minutes. Higher quality audio services, offering content at 96 – 128 kbps, would be available for more than 20 minutes.

When it comes to MUX 3, this ensemble configuration would provide the listener with additional services with probability 0.6 and more, that is more than half an hour in a 60 minute time period, regardless of chosen bitrate.

In case of MUX 4, an additional 16 kbps data program would be available with probability 0.83 over a 60 minute time period. Whereas, an audio program broadcasted at lower bitrates would be available with probability of 0.65 and higher (39 minutes and more). Services of higher bitrates would be available more than a quarter of an hour.

As shown, introduction of the SMOC adaptive bitrate assignment and resource allocation method would lead to an increase in the efficiency of resource management in a single ensemble. Any resource savings could be utilized to introduce additional audio or data services, depending on the broadcaster's requirements.

It is worth mentioning, that this analysis was performed with a 100% confidence, that the decision, related with the profile and transmitted content, is accurate as can be. This scenario is justified, since broadcasters prepare their schedule in a timely manner. Most often, they have a fixed organization, so that the listeners may easily remember when to tune in to their favorite broadcast. Furthermore, the schedule is available to the user several days in advance.

Of course, the process of preparing the schedule is carried out manually by human experts. However, an automated way of managing and classifying transmitted content and services can provide an important component for a complete information retrieval system in a single multiplex. Nevertheless, the accuracy of automatic audio content classification does not reach 100%, most often it oscillates around 70%. This indicates, that when considering a total automation, the probability of introducing additional audio or data services may differ.

4.3. Discussion

In the DAB+ broadcasting system, service providers send service components and additional data not directly to the transmitter site, but to the ensemble provider, who operates the ensemble multiplexer. It should be emphasized, that all service providers and the ensemble provider have to share the FIC signaling channel. That is why cooperation among different contributors to the DAB+ transmission signal has to be managed appropriately. This is normally performed based on contracts between service providers and the ensemble provider.

Resources are allocated based on not only transmission capacities, but also coding resources, necessary for the signaling of multiplex configuration, service and other information transmitted to the receiver. What is crucial, the technical support depends on the network scenario and operational requirements. In a more static scenario there are lower requirements for management tasks, since changes in the configuration are less common.

Furthermore, timing aspects have to be taken into account. Data streams provided by different content and service providers have to be not only synchronized, but also carefully coordinated in a timely fashion to prevent any malfunction, especially on the end user receiver side.

When analyzing the situation of European broadcasters one can notice, that the number and offer of local broadcast stations is much broader than nationwide stations. It could be assumed, that a smaller range should result in a smaller number of users. However, there is a possibility that lower costs of broadcasting in digital, especially when using adaptive multiplexing in DAB+, will contribute to an increase in the activity on a regional level.

Any increase in efficiency within a single 1.5 MHz frequency block, related with the quality and number of offered services, will enable local journalists and news agencies to pursue their passions in making news reports and producing content, which nowadays cannot be realized due to limited bandwidth. Broadcasters and content providers will welcome any savings in bandwidth, as bandwidth, in this case resources available in a single multiplex ensemble, is considered the most limited and precious asset.

Chapter 5: SMOC Technological Demonstrator

According to [43][103][105], the multiplex may be reconfigured from time to time during transmission. When the multiplex configuration is about to change, the new information, together with the timing of the change, is transported via the MCI. It indicates in advance what changes of the multiplex are going to take place.

The signaling of multiplex reconfiguration starts in advance in the so-called preparation phase, lasting up to 6 s. During this time, the ensemble identification is extended by a byte signaling the instant of planned reconfiguration in terms of the frame count. The reconfiguration includes sub-channel reorganization, service reorganization, or both.

In parallel, the current and next MCI will be signaled at least three times to the receiver using the respective FIGs. Furthermore, service information related to the next configuration can be also optionally provided in advance during the preparation phase. The ensemble multiplexer has to ensure this by communicating with particular service providers, taking into account resource allocation.

In order to test the concept and efficiency of the proposed adaptive bitrate assignment and resource allocation method for the DAB+ broadcasting system, a fully functional technological demonstrator has been built [29].

5.1. Radio Link

For the purpose of this test, the multiplex has been given the name of SMOCmuxPG. The signal samples used during this test were sourced from EBU SQUAM CD [102] and a private music library. The technological demonstrator was designed according to [43][103][105].

The adaptive forming of the multiplex ensemble, including content and service management, was performed on the transmitting side of the radio link. The receiving side, namely the user device, remained untouched. The block diagram of signal forming in the DAB+ system, with the additional SMOC adaptive multiplexer, is shown in Fig. 5.1. The block diagram of the SMOC adaptive multiplexer is described in Fig. 5.2.

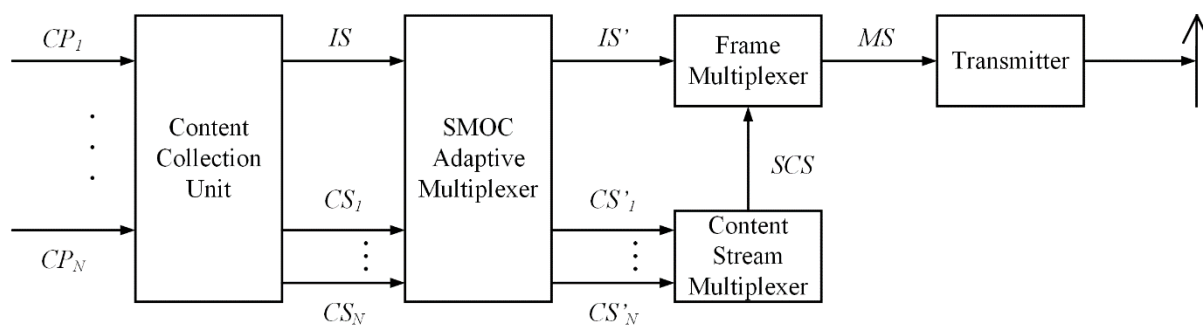

Fig. 5.1. Block diagram of signal forming in the SMOC DAB+ radio link.

As shown, content providers CP_1 to CP_N are the source of N signals, including speech, music and data, which are fed to the *Content Collection Unit*. The *Content Collection Unit* processes those signals into N content signals CS_1 to CS_N , one for each content provider, and one information signal IS , which contains information about the multiplex ensemble and available services.

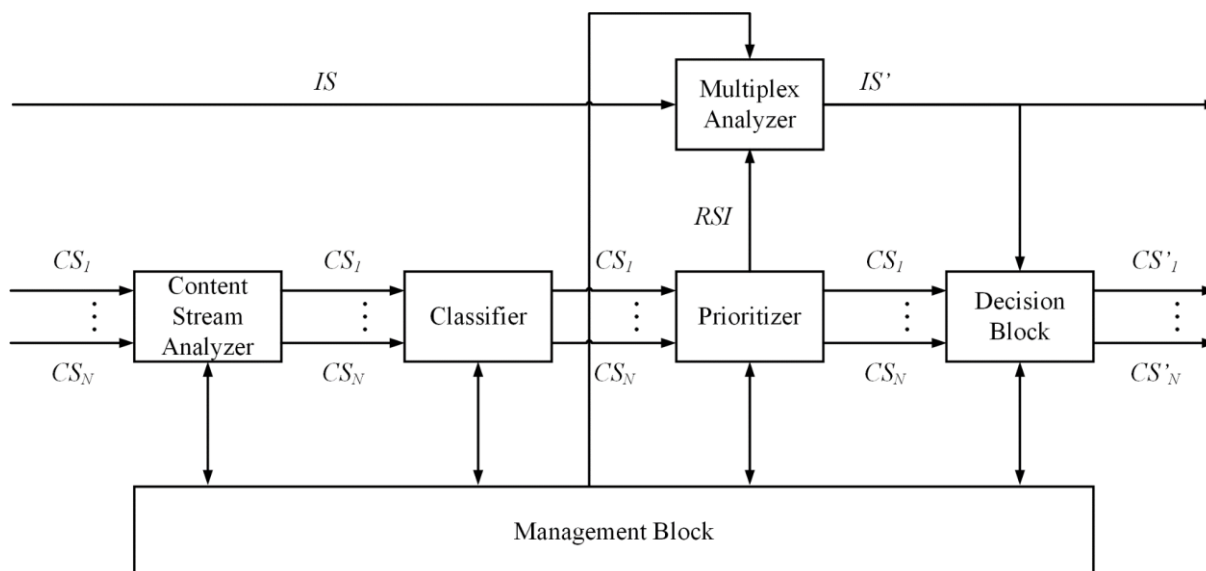

Fig. 5.2. Block diagram of the SMOC adaptive multiplexer.

The SMOC adaptive multiplexer performs the content analysis of incoming CSs using the *Content Stream Analyzer* block. Next, it performs the classification and assigns priorities accordingly. The result signal RSI , including information concerning the new assigned priority, is fed to the *Multiplex Analyzer* block, which performs an analysis, whether the reallocation of resources can be performed. Based on the result of this analysis, the modified information signal IS' is fed to the *Decision Block*, which performs the modification of content signals CS_1 to CS_N . The whole process is monitored by the *Management Block*.

The modified content signals CS'_1 to CS'_N are fed to the *Content Stream Multiplexer* block, which produces a summary content stream SCS . The SCS , along with the IS' , are fed to the *Frame Multiplexer* block, which produces the multiplex stream MS , which is later fed to the transmitter. The designed solution has been submitted to the Polish Patent Office on March 2016 [35].

The block diagram of the designed SMOCmuxPG multiplex radio link is shown in Fig. 5.3. Due to legal conditions, the transmission was realized using a wired medium.

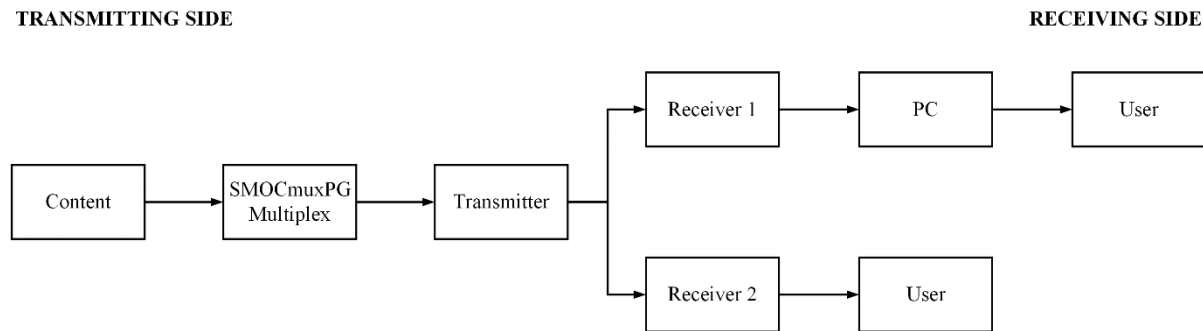

Fig. 5.3. Block diagram of the SMOCmuxPG radio link.

The transmitting side was a SDR (*Software-Defined Radio*) laboratory stand specially designed for this test. Whereas, the receiving side consisted of 2 devices: one programmable receiver and one consumer device purchased on the market. The description of the whole concept of SDR, including its capabilities and applications, can be found in [11][34][53][71].

5.1.1. Transmitting Side

The transmitting side was a laboratory stand developed in SDR technology. It consisted of a Linux-based desktop PC (*Personal Computer*) and a USRP (*Universal Software Radio Peripheral*) B200mini device from Ettus Research. The software, responsible for managing content, services, ensemble and multiplex, was written in C/C++ and used Opendigitalradio. The Opendigitalradio environment offers a set of tools developed by a NPO (*Non-Profit Organization*) in order to promote digital radio broadcasting.

The software, developed for the purpose of this test, communicated with the USRP using the UHD (*USRP Hardware Driver*) software API (*Application Programming Interface*). The features of the USRP B200mini are described in Tab. 5.1. The architecture of the USRP B200mini is shown in Fig. 5.4.

Tab. 5.1. Features of USRP B200mini.

Specification	Typical	Unit
RF Performance		
Power Output	>10	dBm
Receive Noise Figure	<8	dB
Conversion Performance and Clocks		
ADC Sample Rate (Max.)	61.44	MS/s
ADC Resolution	12	bits
DAC Sample Rate (Max.)	61.44	MS/s
DAC Resolution	12	bits
Host Sample Rate (16b)	61.44	MS/s
Frequency Accuracy	± 2.0	ppm
Power		
USB Power	5	V

The USRP had a wide operating frequency range from 70 to 6000 MHz, which covers Band III utilized in DAB+. The device used a user-programmable Xilinx Spartan-6 FPGA (*Field-Programmable Gate Array*) and a Analog Devices AD9364 RFIC (*Radio Frequency Integrated Circuit*) transceiver as the RF front-end. The device was powered by a USB (*Universal Serial Bus*) 3.0 connection, which was also used for exchanging data with the host computer. It also had a built-in GPIO (*General-Purpose Input/Output*), JTAG (*Joint Test Action Group*) and PPS (*Pulse-Per-Second*) time connector.

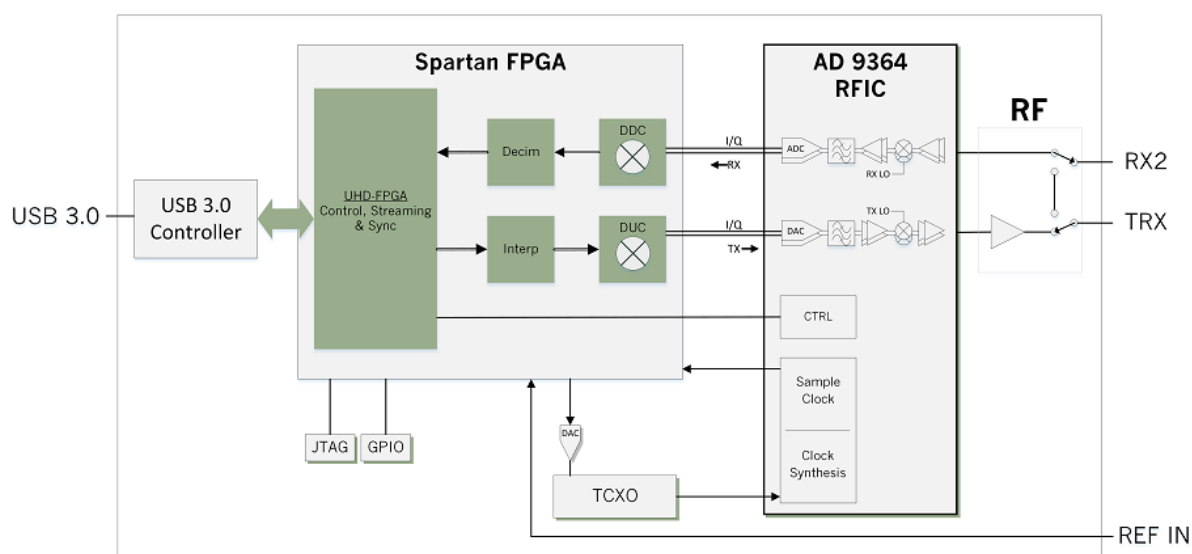

Fig. 5.4. Architecture of USRP B200mini [106].

The block diagram of the transmitting side of the radio link, comprising of the host PC and USRP device, is shown in Fig. 5.5. The process of managing content, including audio coding, as well as service and ensemble multiplexing, was performed by the PC. The depiction of the operating SDR-based transmitter is shown in Fig. 5.6.

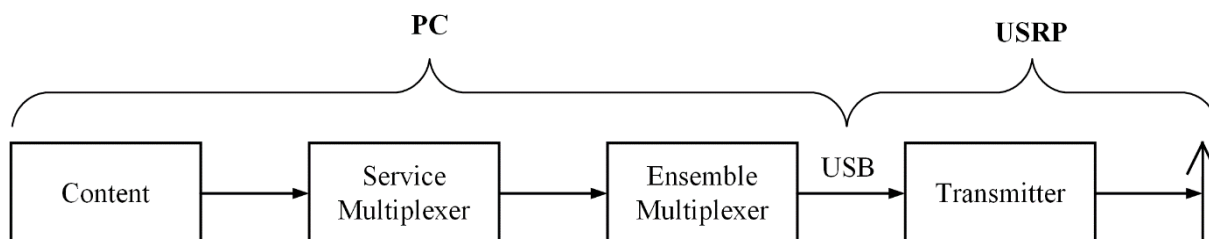

Fig. 5.5. Block diagram of the transmitting side.

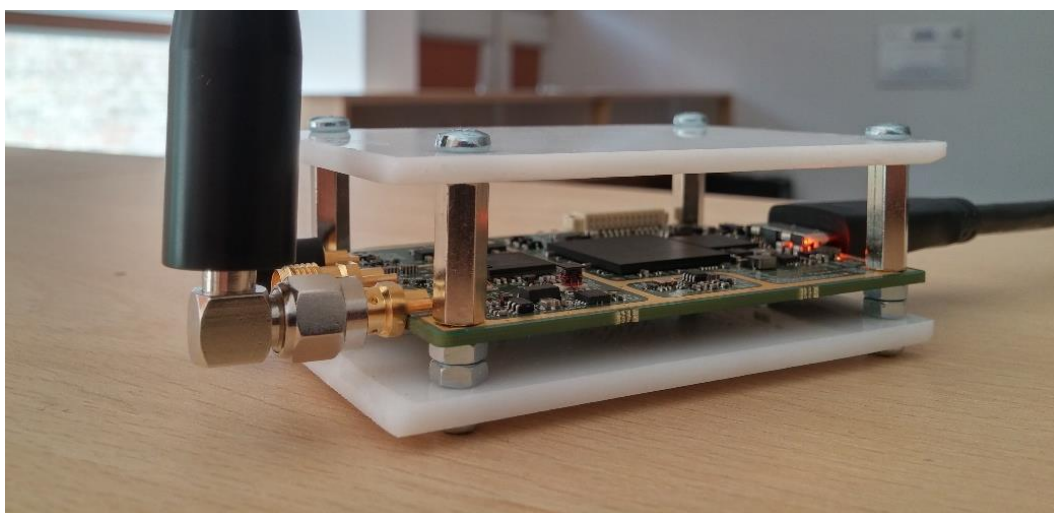

Fig. 5.6. Operating SDR-based DAB+ transmitter.

The DAB+ transmitter consisted of a number of functional blocks, as shown in Fig. 5.7. The ETI (*Ensemble Transport Interface*) output signal from the ensemble multiplexer is normally delivered to the transmitter site via distribution network. In this case, it was delivered by the host PC. After COFDM (*Coded Orthogonal Frequency Division Multiplexing*) encoding the DIQ (*Digital In-phase and Quadrature*) output signal was converted from digital to analog. Next, the signal was upconverted to the desired radio frequency. Lastly, the signal was amplified and filtered before it entered the antenna of the USRP device.

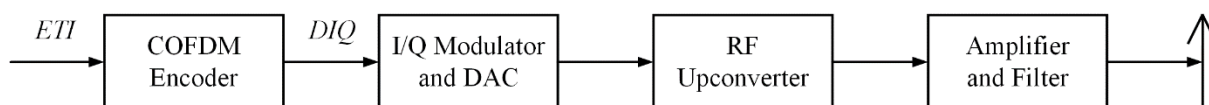

Fig. 5.7. Block diagram of the DAB+ transmitter.

The signal processing blocks of the COFDM encoder are shown in Fig. 5.8. In the delay compensation section, the input signal was delayed within a range of 0 s to more than 1 s, typically in steps of 488 ns (488 ns are conveniently of 2,048 Mbps).

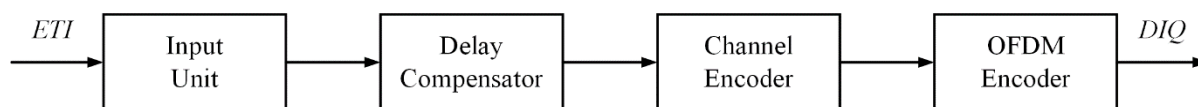

Fig. 5.8. Block diagram of the COFDM encoder.

The channel encoder block performed all necessary encoding, including energy dispersal, convolutional encoding, MSC time interleaving, MSC multiplexing, transmission frame multiplexing and frequency interleaving. The OFDM encoder block mapped the bit stream into DQPSK symbols, and then generated the DIQ baseband signal.

5.1.2. Receiving Side

The receiving side consisted of 2 devices: a programmable DAB+ radio receiver and a commercially available DAB+ receiver bought on the market. The architecture of a typical DAB+ receiver is shown in Fig. 5.9.

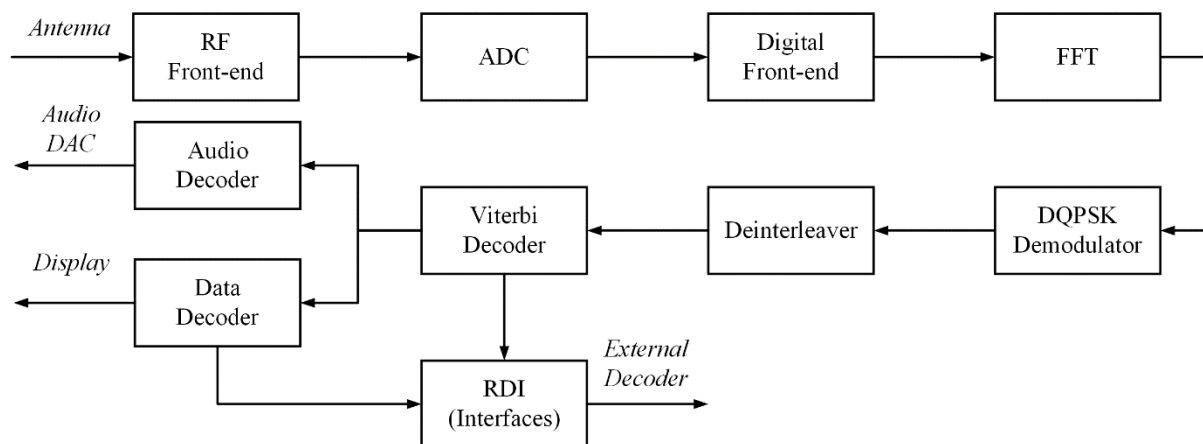

Fig. 5.9. Architecture of the DAB+ receiver.

The signal received from the antenna was first processed in the RF front-end, filtered and mixed to an intermediate frequency or directly to the complex baseband. The resulting signal was then converted to the digital domain using ADC, and then processed in the digital front-end in order to generate a digital complex baseband signal. Next, this signal was treated by applying FFT. Later on, each carrier was differentially demodulated using DQPSK, and the deinterleaving in time and frequency was performed. Finally, the signal was Viterbi decoded, exploiting the redundancy added at the transmitter side in order to minimize the residual error



caused by transmission errors. The output of the Viterbi decoder, in the form of source coded data, including audio and data services, as well as FIC information, was available for further processing. The audio stream was decoded by the audio decoder, whereas the data stream might be transferred to an external decoder through the RDI (*Receiver Data Interface*) or other interfaces. Additional information on the architecture and functionality of a DAB+ receiver may be found in [13][61][86].

The programmable receiver was a DAB+ FM Digital Radio Development Board Pro platform for developing and evaluating DAB/DAB+, SLS and FM with RDS (*Radio Data System*) services. It supported decoding multiple audio services, including DAB/DAB+ Band III and L-Band. The board contained a Keystone T2_L4A_8650C DAB/FM module and a Microchip PIC18F14K50 microcontroller. The device was powered by a USB Mini B connection, which was also used for communicating with the host computer. It had a 3.5 mm Stereo Jack connector for listening and a SMA (*Subminiature version A*) connector for an external antenna. The depiction of the operating programmable receiver is shown in Fig. 5.10.



Fig. 5.10. Operating programmable DAB+ receiver.

The receiver's GUI (*Graphical User Interface*) interface, written in C/C++, responsible for handling the device, is shown in Fig. 5.11. The user interaction with the GUI was realized using a computer mouse and keyboard. The software was designed to operate on any PC (*Personal Computer*) running Windows XP or higher.

The GUI provided information about the label of a service, including additional text information, as well as SLS when available. It also delivered information about the total number of available services, along with the profile and bitrate of the currently selected radio program. The loudness could be adjusted by the user himself, who was also informed about the current error rate of the received signal.



Fig. 5.11. DAB+ programmable receiver GUI user interface:
a) main menu, b) SLS menu.

The second receiver was the TechniSat DigitRadio 350 IR, a commercially available receiver compatible with FM RDS and DAB/DAB+ Band III. The depiction of the operating TechniSat receiver is shown in Fig. 5.12.



Fig. 5.12. TechniSat DigitRadio 350 IR receiver:

a) frequency info, b) bitrate info.

The device also offered integrated Ethernet and Wi-Fi connectivity, Internet radio, UPnP (*Universal Plug-and-Play*) audio streaming, USB audio playback, audio AUX in and out, as well as an illuminated dot-matrix LCD (*Liquid Crystal Display*) display. It provided information about the multiplex ensemble, including the operating frequency, as well as information about the label of a selected service, its bitrate, source codec and channel mode.

5.2. Test Scenario

For the purpose of this test, a fully functional SDR-based technological demonstrator has been built. As in case of the national broadcaster, Band III and transmission mode I have also been chosen. This experiment was carried out in August 2016.

Before starting the initial tests, different ensemble configurations, including the number of available services, their bitrate, additional information, etc., were examined. The capabilities of the host PC, the USRP B200mini, as well as the USB interface, were also taken into consideration.



5.2.1. Multiplex Configuration

After performing an analysis of spectrum occupancy in Band III (174 – 240 MHz) using the Anritsu Spectrum Master MS2724B, an unoccupied channel had been selected, namely channel 7C (192.352 MHz). The bandwidth occupancy during the test is shown in Fig. 5.13, whereas the signal spectrum of the SMOCmuxPG multiplex is shown in Fig. 5.14.

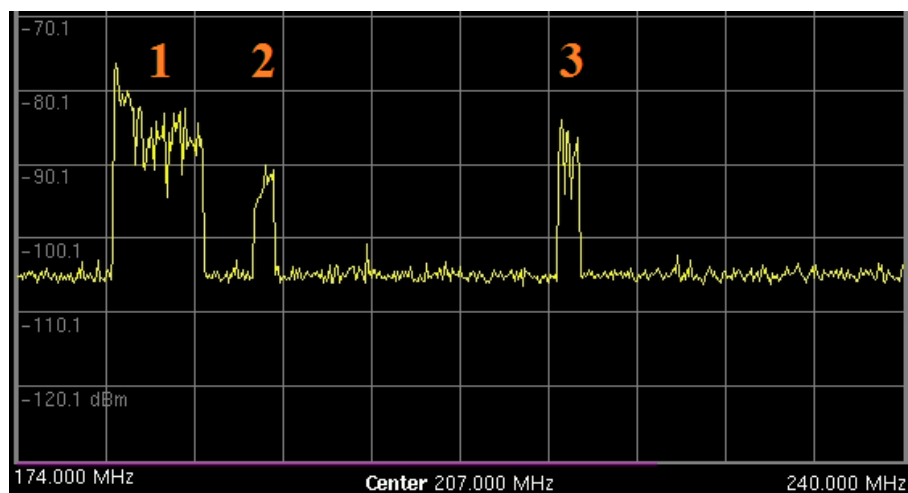

Fig. 5.13. Band III occupancy.

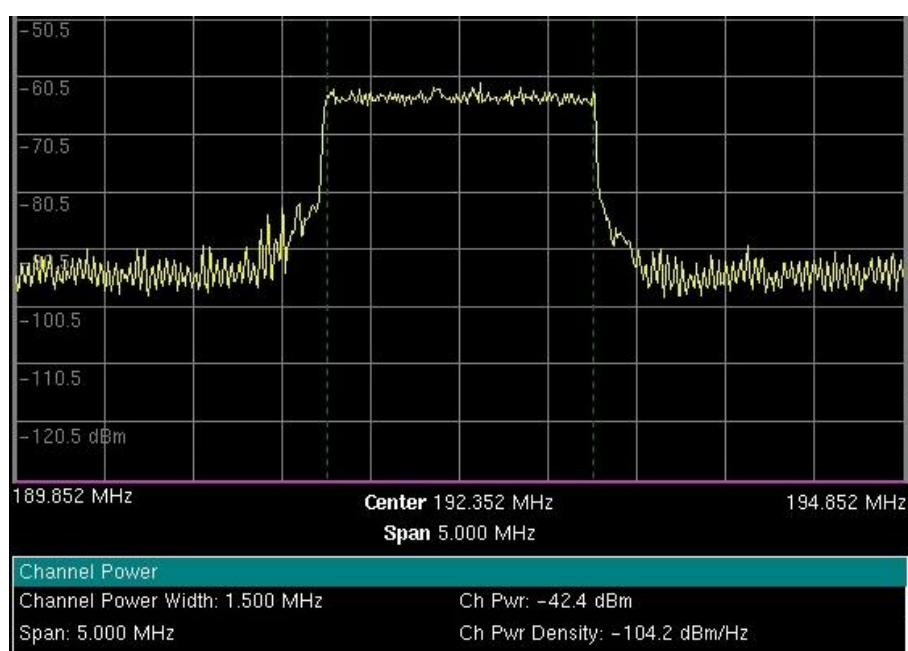

Fig. 5.14. Signal spectrum of the SMOCmuxPG DAB+ multiplex.

As observed in Fig. 5.13, the signal at center frequency 184.5 MHz, channel width 7 MHz (1), represented one of the Polish DVB-T multiplex, that is *MUX-8*, whereas the one at center frequency 215.072 MHz, channel width 1.536 MHz (3), depicted the Polish Radio DAB+ multiplex, *DAB-GDA*. Signal (2) was the designed SMOCmuxPG multiplex.

5.2.2. Ensemble Configuration

Before starting the initial tests it was decided to investigate the technical capabilities of the designed SDR-based transmitting side of the radio link, including the desktop PC and USRP device. First, one radio program was broadcasted, with varying CU allocation and bitrate assignment. Later on, the number of transmitted DAB+ programs was successfully increased. Eventually, after performing a series of tests, a stable transmission was achieved for an ensemble consisting of less than 6 services.

In the proposed research scenario, the multiplex ensemble consisted of 5 radio programs named: *Program 1*, *Program 2*, *Program 3*, *Program 4*, as well as an additional periodical (pop-up) radio program, *Program 5*. The content transmitted over particular radio programs did vary. The periodical program was delivering content only under specific conditions, that is when there were enough free (saved) ensemble resource to introduce an additional service. Otherwise, it was mimicking the *Program 1* service. The initial configuration is described in Tab. 5.2, whereas the configuration of each step, including the parameters of particular services, is described in Tabs. 5.3-5.6. The initial allocation of CUs and bitrate assignment is shown in Fig. 5.15. The allocated resources ranged from 156 CUs (208 kbps) to 252 CUs (336 kbps).

Tab. 5.2. SMOCmuxPG initial ensemble configuration.

No.	Service	Audio codec	Bitrate [kbps]	Net Bitrate [kbps]	Sub-channel	No. of CUs	Start CU	Stop CU
1	Program 1	HE-AAC v1	64	57.9	1	48	0	47
2	Program 2	AAC-LC	128	115.8	2	96	48	143
3	Program 3	HE-AAC v1	72	65.2	3	54	144	197
4	Program 4	HE-AAC v1	72	65.2	4	54	198	251
5	Program 5	HE-AAC v1	64	57.9	1	48	0	47

In this configuration, 252 CUs were allocated for audio services, whereas 612 CUs remained free. No data services were included. All 5 available services occupied a total of 336 kbps, whereas 816 kbps remained free. For the purpose of this test, 252 CUs (336 kbps) was viewed as the maximum number of available resources in a single multiplex ensemble, due to limitations of the USRP device and host PC.

Tab. 5.3. SMOCmuxPG ensemble configuration – step #1.

No.	Service	Audio codec	Bitrate [kbps]	Net Bitrate [kbps]	Sub- channel	No. of CUs	Start CU	Stop CU
1	Program 1	HE-AAC v1	64	57.9	1	48	0	47
2	Program 2	AAC-LC	128	115.8	2	96	48	143
3	Program 3	HE-AAC v1	72	65.2	3	54	144	197
4	Program 4	HE-AAC v1	72	65.2	4	54	198	251
5	Program 5	HE-AAC v1	64	57.9	1	48	0	47

Tab. 5.4. SMOCmuxPG ensemble configuration – step #2.

No.	Service	Audio codec	Bitrate [kbps]	Net Bitrate [kbps]	Sub- channel	No. of CUs	Start CU	Stop CU
1	Program 1	HE-AAC v1	64	57.9	1	48	0	47
2	Program 2	HE-AAC v1	64	57.9	1	48	0	47
3	Program 3	HE-AAC v1	72	65.2	3	54	48	101
4	Program 4	HE-AAC v1	72	65.2	4	54	102	155
5	Program 5	HE-AAC v1	64	57.9	1	48	0	47

Tab. 5.5. SMOCmuxPG ensemble configuration – step #3.

No.	Service	Audio codec	Bitrate [kbps]	Net Bitrate [kbps]	Sub- channel	No. of CUs	Start CU	Stop CU
1	Program 1	HE-AAC v1	64	57.9	1	48	0	47
2	Program 2	HE-AAC v1	64	57.9	1	48	0	47
3	Program 3	HE-AAC v1	64	57.9	3	48	48	95
4	Program 4	AAC-LC	96	86.5	4	72	96	167
5	Program 5	HE-AAC v1	64	57.9	1	48	0	47

Tab. 5.6. SMOCmuxPG ensemble configuration – step #4.

No.	Service	Audio codec	Bitrate [kbps]	Net Bitrate [kbps]	Sub- channel	No. of CUs	Start CU	Stop CU
1	Program 1	HE-AAC v1	64	57.9	1	48	0	47
2	Program 2	HE-AAC v1	64	57.9	1	48	0	47
3	Program 3	HE-AAC v1	64	57.9	3	48	48	95
4	Program 4	AAC-LC	96	86.5	4	72	96	167
5	Program 5	HE-AAC v1	112	101.1	5	84	168	251

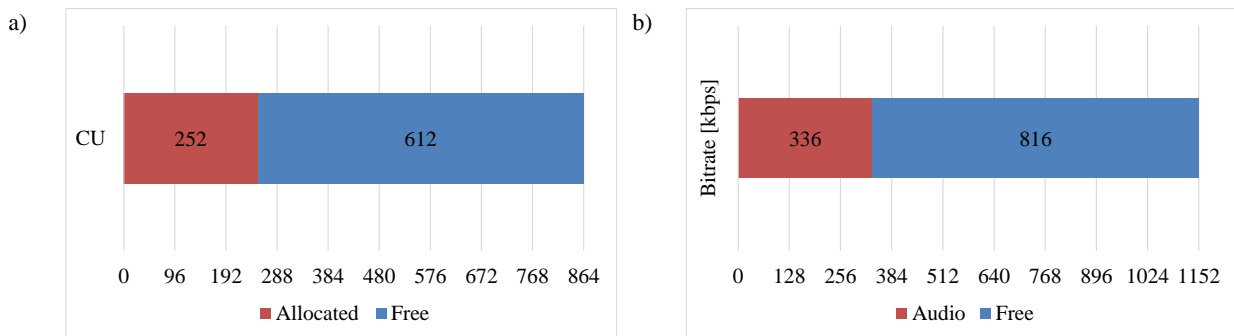

Fig. 5.15. SMOCmuxPG initial ensemble configuration.

In this experiment, the SMOC method was investigated in a 4-step test scenario, including the adaptive bitrate assignment and resource allocation of the designed ensemble. It involved reallocating CUs, sharing the same sub-channel, as well as introducing an additional pop-up radio program whenever there were enough saved resources available.

5.3. Results

The adaptive bitrate assignment and resource allocation method did not affect the receiver devices. Both the programmable receiver and commercial TechniSat DigitRadio 350 IR enabled a stable reception of transmitted radio programs. This was verified by performing a series of tests, including a study concerning reception stability and reliability of the designed radio link, as well as a subjective quality assessment performed on a group of 16 listeners.

5.3.1. Reception

The reconfiguration process took less than 1 s. Furthermore, it did not involve or require any intervention from the user side and was totally automatic, even when switching immediately from *step #1* to *step #4* of the ensemble configuration. The exemplary GUI user interface of the programmable DAB+ receiver, as well as the display of the commercial TechniSat DigitRadio 350 IR receiver, tuned to SMOCmuxPG, is shown in Fig. 5.16.

Broadcasting systems should be capable of providing reliable services in real-time. Of course, an efficient way of monitoring quality is a crucial aspect. In order to test the efficiency of the designed SMOC DAB+ transmitter, the radio link was monitored over a period of 60 minutes. The measurements were performed using the programmable DAB+ receiver.

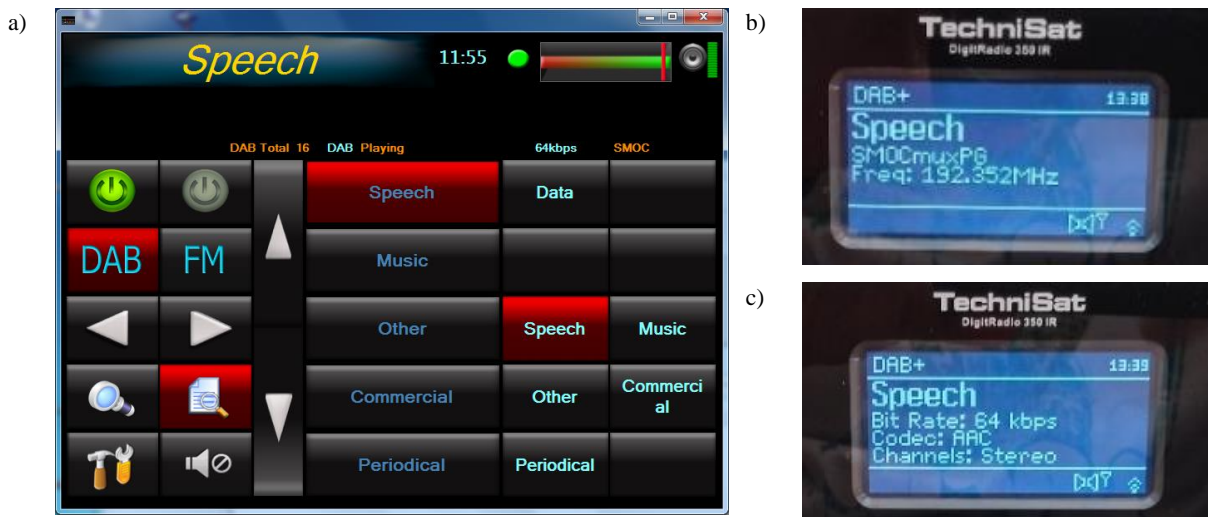

Fig. 5.16. DAB+ receivers tuned in to SMOCmuxPG:
a) GUI user interface, b) frequency info, c) bitrate info.

The structure of the DAB+ frame, as well as other parameters related with the standard, enable to monitor transmission quality in a number of ways. One of them is by monitoring the FIB Count and FIB Error Rate, as shown in Fig. 5.17 and Fig. 5.18, respectively. The FIB Count FIB_{Count} , representing the total number of N received FIB frames, is defined in Form. (5.1) as:

$$FIB_{Count} = \sum_{i=1}^N FIB_i . \quad (5.1)$$

The second parameter, namely FIB Error Rate $FIB_{ErrorRate}$, representing the relation between received erroneous and total FIB frames, was calculated according to Form. (5.2):

$$FIB_{ErrorRate} = \frac{N_E}{N_T} , \quad (5.2)$$

where N_E is the number of received erroneous FIB frames, whereas N_T represents the total number of received FIB frames.

As shown, the SMOC technological demonstrator operated in an appropriate way. The character of FIB Count is nearly linear, which means that there number of received FIB frames is proportional to the operating time. The multiplex also provides a stable error rate at approx. $1.35 \cdot 10^{-2}$. This indicated, that the designed multiplex provided stable reception conditions.

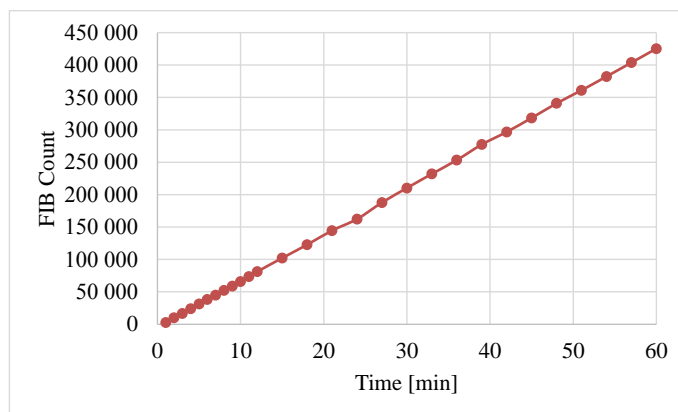

Fig. 5.17. FIB Count of SMOCmuxPG.

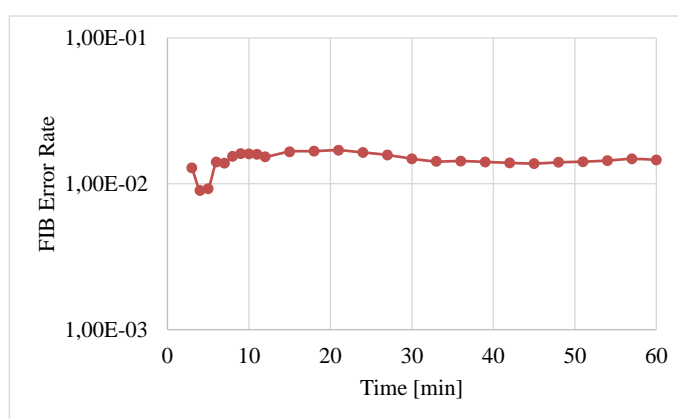

Fig. 5.18. FIB Error Rate of SMOCmuxPG.

What is worth mentioning, any malfunction in the transmitting side would lead to changes in the character of presented graphs. Eventually, some services would be simply unavailable in particular conditions or time periods. This degradation in quality would be clearly visible in the subjective scores provided by the listeners during any quality assessment study. In order to raise the efficiency of allocating physical resources for different radio programs in a single multiplex, those radio programs should be also perceived by the user in a subjective way as of high quality.

5.3.2. Subjective Quality Assessment

The subjective test, related with the quality of the designed SMOC technological demonstrator, was performed according to recommendation [110] on a group of 16 listeners, aged 20-25 years old. None of them had hearing disorders. Each individual was asked to assess the overall quality of every real-time DAB+ broadcasted radio program in the SMOCmuxPG ensemble configuration, in a 5-step MOS scale.



All participants took a training phase before starting the essential listening test in order to learn the functionality of the user interface and become familiar with the listening equipment. Tests were performed in turns, one individual after another. A single session took a few minutes. Listeners were allowed to adjust the volume according to their preferences. Only the name of the currently ranked radio program was given. Tests were conducted using AKG K550 closed-back headphones.

Listeners were not informed about the current assigned bitrate for each individual radio program, regardless of the actual configuration. Neither were they informed when the reconfiguration of the ensemble will take place, and what will be the next out of 4 steps. The subjective results are shown in Fig. 5.19. Obtained results have been processed using the ANOVA statistical analysis ($P = 0.14$, $F_{crit} = 2.03$, $F = 1.59$, $\alpha = 0.05$). The confidence interval was set to 95%.

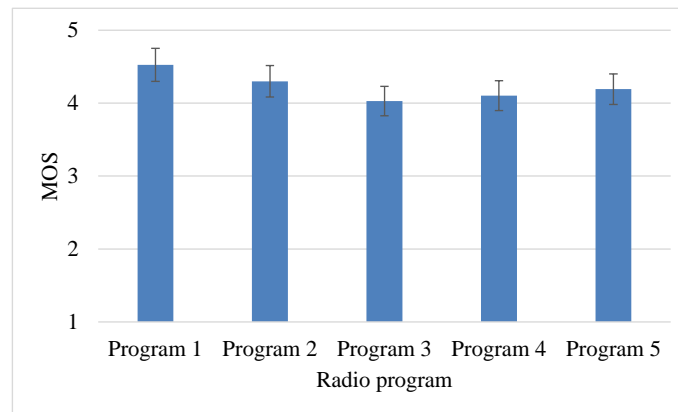

Fig. 5.19. Subjective quality assessment of SMOCmuxPG.

According to obtained results, each broadcasted program of the adaptive SMOCmuxPG DAB+ multiplex received an overall grade of >4.0 , which fulfills the broadcast quality criterion. This indicates, that the SMOC method is an efficient way of managing content and forming the ensemble of the DAB+ broadcasting system. The proposed adaptive bitrate assignment and resource allocation method enables to provide high quality audio services under limited resource conditions in a single multiplex. Furthermore, as indicated by the listeners, the reconfiguration of the multiplex, related with the adaptive bitrate assignment and resource allocation, was carried out in a seamless way, which did not affect the end perceived quality. Additionally, any signal loss or occurring errors would be clearly visible in lower scores during the quality assessment study. Currently, any interruption in offered services is viewed by the user as unacceptable.

During the study, there was no need for e.g. a reselect of a service, changing the current service to another, retuning or turning the receiver off and on again. The adaptive bitrate assignment and resource allocation was imperceptible and unnoticeable. What is crucial, no modifications in the receiving side were needed. The proposed SMOC method proved to be fully compatible with the DAB+ digital broadcasting standard. It can be used to increase the efficiency of allocating physical resources for different radio programs in a single multiplex. As mentioned in the patent application [35], the designed solution can be utilized in other digital broadcasting systems.

5.4. Discussion

In March 2016, the Polish NBC released a report on DAB+, summarizing the process of digitizing radio in Poland [119]. This document contains a summary of the current situation of analog radio, as well as the current state of work in digitizing radio programs and the perspectives for future development. It presents recommendations for further work on the development of the DAB+ radio market in Poland. The report is a reliable basis for further work, concerning both legal acts and strategies for implementing the DAB+ broadcasting system on a national level.

According to the report, as well as the European Radio Forum held in Kraków on October 6th 2016, a full introduction of DAB+ should be performed in cooperation between both the public and private broadcasters [122]. Furthermore, as pointed out by representatives of governments and the business sector, it should be preceded by further studies and research.

Furthermore, national broadcasters of the Visegrad Group are planning to team up and introduce a new radio program, called *Radio V4*. This program will be broadcasted in national languages of each country of the V4. It will include news and current affairs, as well as cultural, social and political topics [123]. This indicates, that further work is required in order to provide reliable services at an acceptable level of quality. Additionally, both broadcast and transmission quality of offered services will have to be measured on a regional, national and international level.

During the study it was noticed, that at particular parts of the day, *Radio Rytm* shared the same broadcast material, including news and current affairs, as *Polskie Radio 24*. Despite transmitting the same content, i.e. female or male speech during the news report every 30 minutes, the bitrate assigned for *Radio Rytm* did not change (fixed 96 kbps compared with 64 kbps assigned for *Polskie Radio 24*). As it was heard on air of *PR Jedyńka*, the same mechanism of sharing broadcast content is planned between *PR Jedyńka* and *Radio Dzieciom*.

In the nearest future, it is intended to transmit the same broadcast for the youngest listeners on both programs, just like the popular TV series *Teleranek*.

Moreover, the introduction of periodical radio programs, i.e. *Radio Gwiazdka* and *Radio Chopin*, is a cyclic process. Upcoming annual events, such as holidays, concerts, cultural and sports events, as well as other happenings, could be transmitted on air whenever there are free multiplex resources available. It is worth mentioning, that the International Fryderyk Chopin Piano Competition and the International Henryk Wieniawski Violin Competition, held every 5 years, as well as the Winter and Summer Olympic Games or World Cups, held every 4 years, are events that attract many people from all over the world. The SMOC adaptive bitrate assignment and resource allocation method could be utilized to manage multiplex resources and to broadcast each and every of these upcoming events. The proposed SMOC method, along with the PCP and MCF metrics, could be also utilized during the planning phase of a particular ensemble and allocating resources to individual public or private broadcasters, as well as for evaluation and maintenance purposes.

Of course, an adaptive bitrate assignment or resource allocation mechanism will be most efficient if the multiplex is owned by one and the same subject. If the ensemble is shared between multiple subject, i.e. different private broadcasters competing with one another, regulations are needed to ensure fair and transparent access to multiplex resources. However, examples from the digital television market, i.e. *MUX-1* and *MUX-2*, have shown that such a solution is possible.

As observed, the digital radio market continues to grow, and so does the demand for new efficient and reliable services. Thanks to its full compatibility with the DAB+ standard, the SMOC adaptive bitrate assignment and resource allocation method could be easily implemented as an extension of the transmitting side of the radio link, as no modifications of the receiving side are required. The consumer device remained untouched. Additionally, any saving in multiplex resources could be used not only to introduce new regular and periodical programs, or increase the quality of currently offered services, but also to transmit alarm information, considering traffic or weather conditions, tourist information, etc.

The proposed SMOC method, along with the novel PCP and MCF metrics, could be easily implemented on either regional or national levels. This mechanism could increase the efficiency of allocating physical resources for different radio programs in a single multiplex. In the proposed solution, the efficiency parameter is related with the number and quality of offered services, particularly radio programs, in a single 1.5 MHz frequency block.

It is worth mentioning that broadcasters, telecoms and content providers continuously seek new ways to optimize their use of bandwidth in order to maximize the quality of offered services. They will welcome any savings in bandwidth, as bandwidth, in this case resources available in a single multiplex ensemble, is considered the most limited and precious asset.



Chapter 6: Summary – Main Achievements of the Dissertation

As it was mentioned at the beginning, the main aim of this dissertation was to develop a new adaptive bitrate assignment and resource allocation method for the DAB+ broadcasting system, in order to provide high quality services, as well as increase the efficiency of allocating physical resources for different radio programs in a single multiplex. Considering the thesis, which reads: *A high transmission efficiency in the DAB+ digital broadcasting system may be achieved through an adaptive bitrate assignment method for radio programs, under limited physical resource conditions of this system* – the study was carried out in order to confirm the whole concept, and thereby prove the thesis.

The studies were carried out in two ways, including an analysis of the proposed SMOC method using content recorded from different radio programs, as well as building a fully operational and functional technological demonstrator. It is worth mentioning, that the technological demonstrator proved to be fully compatible with the DAB+ broadcasting standard, as no modification in the receiving devices were needed.

Furthermore, during the study, a considerable amount of research material has been collected, including a survey of user expectations, as well as subjective and objective quality assessment studies of the DAB+ broadcasting system. Obtained results were compared with the parameters of the operating Polish Radio multiplex, which was the starting point for the broadcast and transmission efficiency analysis of the designed adaptive SMOC DAB+ multiplex.

Obtained results, including the subjective and objective quality assessment study, along with the user expectations survey, as well as the simulation analysis of resource allocation in the DAB+ broadcast system and practical verification of the proposed SMOC method, have been described and analyzed in Chapter 3, 4 and 5, respectively.

As shown, the efficiency of the proposed solution relies on a number of factors, e.g. type of content, profile of a radio program, bitrate assignment and resource allocation methods. Furthermore, the number of transmitted radio programs was limited by the technical capabilities of the USRP device and host PC. However, providing high quality services, meeting both QoS

and QoE requirements, is possible, even under limited bandwidth and multiplex resource conditions.

Summarizing, obtained results, presented and analyzed in this dissertation, including both theoretical and practical analysis prove, that they confirm the concept of construction and operation of an adaptive DAB+ multiplex and prove the correctness of the thesis.

The main original achievements of this dissertation include:

- 1) Developing the algorithmic layer of the SMOC adaptive multiplexing simulator, as well as designing the software and hardware layer of the SDR-based SMOC DAB+ technological demonstrator.
- 2) Assumptions of the whole concept of an adaptive bitrate assignment and resource allocation method for the DAB+ broadcast system, including the development of the algorithmic layer of such a method.
- 3) Designing new metrics for assessing the profile of a radio program (PCP), based on transmitted content, and the efficiency of multiplex resource management (MCF), that can be used when planning the schedule of a particular radio program and configuring the multiplex ensemble.
- 4) Performing a series of tests and analyses of the proposed method on recorded audio material from available DAB+ broadcast radio programs, including different multiplex ensemble configurations.
- 5) Carrying out a series of quality assessment studies of the designed adaptive SMOC DAB+ multiplex technological demonstrator, concerning the stability, reliability, compatibility and efficiency of the proposed solution.
- 6) Carrying out a series of subjective and objective quality assessment studies of the DAB+ broadcast systems, including real-time live broadcasted radio programs, as well as AAC-processed signal samples, along with a survey concerning user expectations related with DAB+.
- 7) Configuring and extending the functionality of the programmable FM/DAB+ receiver, along with developing the GUI user interface.

Future studies may focus on extending the functionality of the proposed method in order to further raise the efficiency of allocating physical resources within a single 1.5 MHz frequency block. This upcoming work may relate to both audio and data services, including regular and periodical (pop-up) radio programs, as well as traffic and alarm information. Furthermore, it would seem quite interesting to extend the research to other digital broadcasting standards, as well as online streaming platforms and next generation cellular systems.





Books, articles, conference papers and patent applications:

- [1] Allamanche E., Herre J., Hellmuth O., Fröba B., Kastner T., Cremer M., “Content-based Identification of Audio Material Using MPEG-7 Low Level Description”, *Proceedings of the 2nd Annual International Symposium on Music Information Retrieval*, pp. 197–204, 2001.
- [2] Bem D. J., Więckowski T. W., Zieliński R. J., “Broadband Satellite Systems”, *IEEE Communications Surveys & Tutorials*, vol. 3, no. 1, pp. 2–15, 2000.
- [3] Berg J., Bustad C., Jonsson L., Mossberg L., Nyberg D., “Perceived Audio Quality of Realistic FM and DAB+ Radio Broadcasting Systems”, *Journal of the Audio Engineering Society*, vol. 61, no. 10, pp. 755–777, 2013.
- [4] Błasiak K., Dobrucki A. B., Kin M. J., Ostrowski M., “Sound quality evaluation of DAB+ musical programs”, *14th International Symposium on Sound Engineering and Tonmeistering*, Wrocław, Poland, pp. 1–6, 2011.
- [5] Bosi M., Goldberg R. E., *Introduction to Digital Audio Coding and Standards*, Springer, 2002.
- [6] Bossert M., *Channel coding for telecommunications*, John Wiley & Sons, 1999.
- [7] Brachmański S., Kin M. J., “Assessment of speech quality in Digital Audio Broadcasting (DAB+) system”, *AES 134th Convention*, Rome, Italy, 2013.
- [8] Brandenburg K., “MP3 and AAC explained”, *AES 17th International Conference on High Quality Audio Coding*, Florence, Italy, 1999.
- [9] Brinker den A. C., Breebaart J., Ekstrand P., Engdegård J., Henn F., Kjörling K., Oomen W., Purnhagen H., “An Overview of the Coding Standard MPEG-4 Audio Amendments 1 and 2: HE-AAC, SSC, and HE-AAC v2”, *EURASIP Journal on Audio, Speech, and Music Processing*, vol. 2009, pp. 1–21, 2009.
- [10] Brugger R., Mayer K., “RRC-06 – technical basis and planning configurations for T-DAB and DVB-T”, *EBU Technical Review*, April, pp. 1–10, 2005.
- [11] Buracchini E., “The software radio concept”, *IEEE Communications Magazine*, vol. 38, no. 9, pp. 138–143, 2000.
- [12] Chen B., Sundberg C. E. W., “An Integrated Error Correction and Detection System for Digital Audio Broadcasting”, *IEEE Transactions on Broadcasting*, vol. 46, no. 1, pp. 68–78, 2000.
- [13] Cho J., Cho N., Bang K., Park M., Jun H., Park H., Hong D., “PC-Based Receiver for Eureka-147 Digital Audio Broadcasting”, *IEEE Transactions on Broadcasting*, vol. 47, no. 2, pp. 95–102, 2001.

- [14] Cho S., Lee G., Bae B., Yang K., Ahn C. H., Lee S. I., Ahn C., “System and Services of Terrestrial Digital Multimedia Broadcasting (T-DMB)”, *IEEE Transactions on Broadcasting*, vol. 53, pp. 171–178, 2007.
- [15] Clarke R. H., “A statistical theory of mobile-radio reception,” *Bell System Technical Journal*, vol. 47, no. 6, pp. 957–1000, 1968.
- [16] Cohen L., “Time-frequency Distributions – a review”, *Proceedings of the IEEE*, vol. 77, no. 7, pp. 941–981, 1989.
- [17] Dobrucki A. B., Kozłowski P., “Evaluation of the quality of audio signals transmitted by the telecommunication channels”, *Przegląd Telekomunikacyjny + Wiadomości Telekomunikacyjne*, vol. 6, pp. 235–241, 2010.
- [18] Dymarski P., Kula S., “Fundamentals of Communications Systems”, in: *Encyclopedia of Life Support systems. An integrated compendium of Twenty Encyclopedias*, pp. 1–24, 2007.
- [19] Dymarski P., Kula S., Thanh N., “QoS Conditions for VoIP and VoD”, *Journal of Telecommunications and Information Technology*, vol. 3, pp. 29–37, 2011.
- [20] Faller C., Juang B. H., Kroon P., Lou H. L., Ramprasad S. A., Sundberg C. E. W., “Technical Advances in Digital Audio Radio Broadcasting”, *Proceedings of the IEEE*, vol. 90, no. 8, pp. 1303–1333, 2002.
- [21] Fu Z., Lu G., Ting K. M., Zhang D., “A Survey of Audio-Based Music Classification and Annotation”, *IEEE Transactions on Multimedia*, vol. 13, no. 2, pp. 303–319, 2011.
- [22] Gajewski S., “Design of OFDM-based Radio Communication Systems for Coast-to-Sea and Coast-to-Air Propagation Environments”, *Polish Maritime Research*, vol. 23, no. 1, pp. 12–19, 2016.
- [23] Gajewski S., “Soft – Partial Frequency Reuse Method for LTE-A”, *Radioengineering*, vol. 26, no. 1, pp. 359–368, 2017.
- [24] Gans M. J., “A power-spectral theory of propagation in the mobile-radio environment”, *IEEE Transactions on Vehicular Technology*, vol. 21, no. 1, pp. 27–38, 1972.
- [25] **Gilski P.**, Gajewski S., Stefański J., „Quality Aspects in Digital Broadcasting and Webcasting Systems: Bitrate versus Loudness”, *Journal of Telecommunications and Information Technology* (accepted for publication).
- [26] **Gilski P.**, Katulski R. J., “Media elektroniczne w życiu współczesnego człowieka”, *Elektronika – konstrukcje, technologie, zastosowania*, vol. 3, pp. 7–11, 2016.
- [27] **Gilski P.**, Katulski R. J., “Rola komunikacji bezprzewodowej w życiu współczesnego człowieka”, *Elektronika – konstrukcje, technologie, zastosowania*, vol. 1, pp. 3–9, 2017.
- [28] **Gilski P.**, Stefański J., “Adaptacyjna metoda doboru przepływności przydzielanych programom radiowym nadawanym w standardzie DAB+”, *Przegląd Telekomunikacyjny + Wiadomości Telekomunikacyjne*, vol. 6, pp. 305–308, 2016.

- [29] **Gilski P.**, Stefański J., “Adaptacyjna metoda zarządzania zasobami multipleksu w radiofonii cyfrowej DAB+”, *Przegląd Telekomunikacyjny + Wiadomości Telekomunikacyjne* (accepted for publication).
- [30] **Gilski P.**, Stefański J., “Badanie efektywności kodeków źródłowych w radiofonii cyfrowej DAB+”, *Przegląd Telekomunikacyjny + Wiadomości Telekomunikacyjne*, vol. 4, pp. 349–352, 2015.
- [31] **Gilski P.**, Stefański J., “Can the Digital Surpass the Analog: DAB+ Possibilities, Limitations and User Expectations”, *International Journal of Electronics and Telecommunications*, vol. 62, no. 4, pp. 353–361, 2016.
- [32] **Gilski P.**, Stefański J., “Digital Audio Broadcasting or Webcasting: A Network Quality Perspective”, *Journal of Telecommunications and Information Technology*, vol. 1, pp. 9–15, 2016.
- [33] **Gilski P.**, Stefański J., “Quality Expectations of Mobile Subscribers”, *Journal of Telecommunications and Information Technology*, vol. 1, pp. 15–19, 2015.
- [34] **Gilski P.**, Stefański J., “Radio programowalne – nowoczesna platforma dydaktyczna”, *Przegląd Telekomunikacyjny + Wiadomości Telekomunikacyjne*, vol. 2–3, pp. 34–38, 2014.
- [35] **Gilski P.**, Stefański J., *Sposób i układ formowania strumieni informacyjnych i usługowych w rozszerzonej radiofonii cyfrowej*, patent application to the Polish Patent Office, no. P.416500, 15.03.2016.
- [36] **Gilski P.**, Stefański J., “Subjective and Objective Comparative Study of DAB+ Broadcast System”, *Archives of Acoustics*, vol. 42, no. 1, pp. 3–11, 2017 (IF 0.661).
- [37] Hagenauer J., “Rate-Compatible Punctured Convolutional RCPC Codes (RCPC Codes) and their Applications”, *IEEE Transactions on Communications*, vol. 36, no. 4, pp. 389–400, 1988.
- [38] Herre J., Dietz M., “MPEG-4 High-Efficiency AAC Coding”, *IEEE Signal Processing Magazine*, May, pp. 137–142, 2008.
- [39] Himmanen H., Hannuksela M. M., Kurki T., Isoaho J., “Objectives for New Error Criteria for Mobile Broadcasting of Streaming Audiovisual Services”, *EURASIP Journal on Advances in Signal Processing*, vol. 2008, pp. 1–12, 2008.
- [40] Hines A., Gillen E., Kelly D., Skoglund J., Kokaram A., Harte N., “ViSQOLAudio: An objective audio quality metric for low bitrate codecs”, *Journal of the Acoustical Society of America*, vol. 137, pp. 449–455, 2015.
- [41] Hines A., Gillen E., Skoglund J., Kelly D., Kokaram A., Harte N., “Perceived Audio Quality for Streaming Stereo Music”, *Proceedings of the 22nd ACM International Conference on Multimedia*, Orlando, USA, pp. 1173–1176, 2010.
- [42] Hines A., Skoglund J., Kokaram A., Harte N., “ViSQOL: an objective speech quality model”, *EURASIP Journal on Audio, Speech, and Music Processing*, vol. 13, pp. 1–18, 2015.
- [43] Hoeg W., Lauterbach T., *Digital Audio Broadcasting: Principles and Applications of DAB, DAB+ and DMB*, 3rd Edition, John Wiley & Sons, 2009.

- [44] Hoehner P., Hagenauer J., Offer E., Rapp C., Schulze H., “Performance of an RCPC-coded OFDM-based Digital Audio Broadcasting (DAB) System”, *Proceedings of the IEEE Global Telecommunications Conference*, pp. 40–46, 1991.
- [45] Hunt K. J., Cesky T., Jeacock T., Mägele M., O’Leary T., Petke G., “The CEPT T-DAB Planning Meeting”, *EBU Technical Review*, Spring, pp. 2–26, 1996.
- [46] Iwacz G., Jajszczyk A., Zajączkowski M., *Multimedia Broadcasting and Multicasting in Mobile Networks*, John Wiley & Sons, 2008.
- [47] Jakes W. C., *Microwave Mobile Communications*, John Wiley & Sons, 1974.
- [48] Janowski L., Papir Z., “Modeling Subjective Tests of Quality of Experience with a Generalized Linear Model”, *Proceedings of the International Workshop on Quality of Multimedia Experience*, pp. 35–40, 2009.
- [49] Jekosch U., *Voice and speech quality perception: assessment and evaluation*, Springer, 2005.
- [50] Kahrs M., Brandenburg K., *Applications of Digital Signal Processing to Audio and Acoustics*, Kluwer Academic Publishers, 1998.
- [51] Karolak M., “Rewolucja czy ewolucja? Przyszłość radia cyfrowego w Polsce”, *Przegląd Telekomunikacyjny + Wiadomości Telekomunikacyjne*, vol. 4, pp. 86–91, 2014.
- [52] Katulski R. J., *Propagacja fal radiowych w telekomunikacji bezprzewodowej*, WKŁ, 2010.
- [53] Katulski R. J., Marczak A., Stefański J., “Technika radia programowalnego”, *Przegląd Telekomunikacyjny + Wiadomości Telekomunikacyjne*, vol. 10, pp. 402–406, 2004.
- [54] Khuri A. I., *Advanced Calculus with Applications in Statistics*, John Wiley & Sons, 2003.
- [55] Kin M. J., “Subjective evaluation of sound quality of musical recordings transmitted via DAB+ system”, *AES 134th Convention*, Rome, Italy, 2013.
- [56] Kowal M., Kubal S., Piotrowski P., Zieliński R. J., “A Simulation Model of the Radio Frequency MIMO-OFDM System”, *International Journal of Electronics and Telecommunications*, vol. 57, no. 3, pp. 323–328, 2011.
- [57] Kowal M., Kubal S., Piotrowski P., Zieliński R. J., “Simulation model of the MIMO-OFDM system compliant with IEEE 802.11n”, *International Conference on Broadband Communications, Information Technology & Biomedical Applications*, Malaga, Spain, 2010.
- [58] Kozamernik F., “Digital Audio Broadcasting – coming out of the tunnel”, *EBU Technical Review*, Spring, pp. 1–22, 1999.
- [59] Kozamernik F., “Digital Audio Broadcasting – radio now and for the future”, *EBU Technical Review*, Autumn, pp. 2–27, 1997.
- [60] Kozamernik F., Laflin N., O’Leary T., “Satellite DSB systems – and their potential impact on the planning of terrestrial DAB services in Europe”, *EBU Technical Review*, January, pp. 1–17, 2002.

- [61] Laar van de F., Philips N., Huisken J., “Towards the next generation of DAB receivers”, *EBU Technical Review*, Summer, pp. 46–59, 1997.
- [62] Lax S., Ala-Fossi M., Jauert P., Shaw H., “DAB: the future of radio? The development of digital radio in four European countries”, *Media, Culture & Society*, vol. 30, no. 2, pp. 151–166, 2008.
- [63] Lee C. H., Shih J. L., Yu K. M., Lin H. S., “Automatic Music Genre Classification Based on Modulation Spectral Analysis of Spectral and Cepstral Features”, *IEEE Transactions on Multimedia*, vol. 11, no. 4, pp. 670–682, 2009.
- [64] Lee Y. J., Lee S. W., Kim Y. H., Lee S. I., Yim Z. K., Choi B. H., Kim S. J., Seo J. S., “Field Trials for Terrestrial Digital Multimedia Broadcasting System”, *IEEE Transactions on Broadcasting*, vol. 53, no. 1, pp. 425–433, 2007.
- [65] Leszczuk M., Janowski L., Romaniak P., Papir Z., “Assessing Quality of Experience for High Definition Video Streaming under Diverse Packet Loss Patterns”, *Signal Processing: Image Communication*, vol. 28, no. 8, pp. 903–916, 2013.
- [66] Ligeti A., Ben Slimane S., “Local Coverage Probability Estimation in Single Frequency Networks”, *Wireless Personal Communications*, vol. 18, pp. 105–128, 2001.
- [67] Łuszczewski K., “Emisja cyfrowa szansą rozwoju rynku radiowego w Polsce”, *Przegląd Telekomunikacyjny + Wiadomości Telekomunikacyjne*, vol. 4, pp. 77–79, 2014.
- [68] Mallat S. G., Zhang Z., “Matching pursuit with time-frequency dictionaries”, *IEEE Transactions on Signal Processing*, vol. 41, no. 12, pp. 3397–3415, 1993.
- [69] Mardia K. V., Jupp P. E., *Directional Statistics*, John Wiley & Sons, 2000.
- [70] Mathia P., “Cyfryzacja radia – szansa dla nadawców”, *Przegląd Telekomunikacyjny + Wiadomości Telekomunikacyjne*, vol. 4, pp. 80–81, 2014.
- [71] Mitola III J., *Software Radio Architecture: Object-Oriented Approaches to Wireless Systems Engineering*, John Wiley & Sons, 2000.
- [72] Moore B. C. J., *An Introduction to the Psychology of Hearing*, Academic Press, 1992.
- [73] Möller S., Chan W. Y., Côté N., Falk T. H., Raake A., Waltermann M., “Speech quality estimation: models and trends”, *IEEE Signal Processing Magazine*, vol. 28, pp. 18–28, 2011.
- [74] Neter J., Wasserman W., Kunter M. H., *Applied Linear Statistical Models*, 3rd Edition, CRC Press, 1990.
- [75] Ozimek E., *Dźwięk i jego percepcja. Aspekty fizyczne i psychoakustyczne*, PWN, 2001.
- [76] Pearl J., Glymour M., Jewell N. P., *Causal Inference in Statistics*, John Wiley & Sons, 2016.
- [77] Peterson W. W., Brown D. T., “Cyclic codes for error detection”, *Proceedings of the IRE*, vol. 49, pp. 228–235, 1961.



- [78] Pinson M. H., Schmidmer C., Janowski L., Pepion R., Huynh-Thu Q., Corriveau P., Younkin A., Le Callet P., Barkowsky M., Ingram W., “Subjective and objective evaluation of an audiovisual subjective dataset for research and development”, *Proceedings of the 5th International Workshop on Quality of Multimedia Experience*, pp. 30–31, 2013.
- [79] Počta P., Beerends J. G., “Subjective and Objective Assessment of Perceived Audio Quality of Current Digital Audio Broadcasting Systems and Web-Casting Applications”, *IEEE Transactions on Broadcasting*, vol. 61, no. 3, pp. 407–415, 2015.
- [80] Roslan-Kuhn K., “Analogowa wyspa – czy cyfrowe radio DAB+”, *Przegląd Telekomunikacyjny + Wiadomości Telekomunikacyjne*, vol. 4, pp. 67–70, 2014.
- [81] Schulze H., Lüders C., *Theory and Application of OFDM and CDMA – Wideband Wireless Communications*, John Wiley & Sons, 2005.
- [82] Skarbek W., *Foundations of Multimedia Techniques*, Warsaw University of Technology, 2016.
- [83] Skarbek W., *Multimedia Techniques – Applications*, Warsaw University of Technology, 2016.
- [84] Snedecor G. W., Cochran W. G., *Statistical Methods*, 8th Edition, Iowa State University Press, 1989.
- [85] Soltau H., Schultz T., Westphal M. Waibel A., “Recognition of music type”, *Proceedings of the IEEE International Conference on Acoustics, Speech and Signal Processing*, pp. 1137–1140, 1998.
- [86] Taura K., Tsujishita M., Takeda M., Kato H., Ishida M., Ishida Y., “A Digital Audio Broadcasting (DAB) Receiver”, *IEEE Transactions on Consumer Electronics*, vol. 42, no. 3, pp. 322–327, 1996.
- [87] Thibault L., Le M. T., “Performance Evaluation of COFDM for Digital Audio Broadcasting Part I: Parametric Study”, *IEEE Transactions on Broadcasting*, vol. 43, no. 1, pp. 64–75, 1997.
- [88] Thoen S., van der Perre L., Engels M., “Modeling the Channel Time-Variance for Fixed Wireless Communications”, *IEEE Communications Letters*, vol. 6, no. 8, pp. 331–333, 2002.
- [89] Tzanetakis G., Cook P., “Musical Genre Classification of Audio Signals”, *IEEE Transactions on Speech and Audio Processing*, vol. 10, no. 5, pp. 293–302, 2002.
- [90] Uhl T., Paulsen S., “The new, parameterized VT Model for Determining Quality in the Video-telephony Service”, *Bulletin of the Polish Academy of Sciences Technical Sciences*, vol. 62, no. 3, pp. 431–437, 2014.
- [91] Uhl T., Rompf M., “New Tool for Investigating QoS in the WWW Service”, *Journal of Telecommunications and Information Technology*, vol. 1, pp. 3–9, 2015.
- [92] Umopathy K., Krishnan S., “Audio Coding and Classification: Principles and Algorithms”, in: *Mobile Multimedia Broadcasting Standards*, Springer, pp. 539–585, 2009.



- [93] Wesołowski K., *Podstawy cyfrowych systemów telekomunikacyjnych*, WKŁ, 2006.
- [94] Winkler S., Faller C., “Perceived Audiovisual Quality of Low-Bitrate Multimedia Content”, *IEEE Transactions on Multimedia*, vol. 8, no. 5, pp. 973–980, 2006.
- [95] Wolters M., Kjöröling K., Homm D., Purnhagen H., “A closer look into MPEG-4 High Efficiency AAC”, *115th Audio Engineering Society Convention*, New York, USA, 2003.
- [96] Woźniak K., Wygnański T., “DAB+: plus czy minus?”, *Media i Marketing Polska*, vol. 1-2, pp. 28–29, 2014.
- [97] Zieliński S., “Is a Multi-Slider Interface Layout Responsible for a Stimulus Spacing Bias in the MUSHRA Test?”, *Archives of Acoustics*, vol. 40, pp. 585–594, 2015.
- [98] Zieliński S., “On Some Biases Encountered in Modern Audio Quality Listening Tests (Part 2): Selected Graphical Examples and Discussion”, *Journal of the Audio Engineering Society*, vol. 64, no. 1/2, pp. 55–74, 2016.

Standardization documents, reports, manuals:

- [99] ANSI ATIS 0100005-2006 Standard, *Auditory non-intrusive quality estimation plus (ANIQUE+): Perceptual model for non-intrusive estimation of narrowband speech quality*, Washington, USA, 2006.
- [100] Chancellery of the Sejm, *Act of 29 December 1992 on Radio Broadcasting and Television*, Journal of Laws No. 7/1993, Item 34.
- [101] EBU Recommendation R 138, *Digital Radio Distribution in Europe*, Geneva, Switzerland, 2013.
- [102] EBU Tech 3253 Technical Document, *Sound Quality Assessment Material recordings for subjective tests (SQAM CD)*, Geneva, Switzerland, 2008.
- [103] ETSI EN 300 401 European Standard, *Radio Broadcasting Systems; Digital Audio Broadcasting (DAB) to mobile, portable and fixed receivers*, Sophia Antipolis Cedex, France, 2006.
- [104] ETSI ES 201 980 European Standard, *Digital Radio Mondiale (DRM); System Specification*, Sophia Antipolis Cedex, France, 2014.
- [105] ETSI TS 102 563 Technical Specification, *Digital Audio Broadcasting (DAB); Transport of Advanced Audio Coding (AAC) audio*, Sophia Antipolis Cedex, France, 2010.
- [106] Ettus Research, *USRP B200mini Data Sheet*, 2016.
- [107] European Network on Quality of Experience in Multimedia Systems and Services (COST Action IC1003), *Qualinet white paper on definitions of quality of experience*, Lausanne, Switzerland, 2013.

- [108] Gandy C., *DAB: an introduction to the Eureka DAB System and a guide to how it works*, BBC, 2003.
- [109] ITU Recommendation BS.1116-1, *Methods for the subjective assessment of small impairments in audio systems including multichannel sound systems*, Geneva, Switzerland, 1997.
- [110] ITU Recommendation BS.1284, *General methods for the subjective assessment of sound quality*, Geneva, Switzerland, 2003.
- [111] ITU Recommendation BS.1387, *Method for objective measurements of perceived audio quality*, Geneva, Switzerland, 2001.
- [112] ITU Recommendation BS.1534-1, *Method for the subjective assessment of intermediate quality level of coding systems*, Geneva, Switzerland, 2003.
- [113] ITU Recommendation P.563, *Single-ended method for objective speech quality assessment in narrow-band telephony applications*, Geneva, Switzerland, 2004.
- [114] ITU Recommendation P.800, *Methods for subjective determination of transmission quality*, Geneva, Switzerland, 1996.
- [115] ITU Recommendation P.861, *Objective quality measurement of telephone-band (300-3400 Hz) speech codecs*, Geneva, Switzerland, 1998.
- [116] ITU Recommendation P.862, *Perceptual evaluation of speech quality (PESQ): An objective method for end-to-end speech quality assessment of narrow-band telephone networks and speech codecs*, Geneva, Switzerland, 2001.
- [117] ITU Recommendation P.862.2, *Wideband extension to Recommendation P.862 for the assessment of wideband telephone networks and speech codecs*, Geneva, Switzerland, 2007.
- [118] ITU Recommendation P.863, *Perceptual objective listening quality assessment*, Geneva, Switzerland, 2014.
- [119] KRRiT, *Radio cyfrowe więcej niż radio: Zielona księga cyfryzacji radia w Polsce*, Warsaw, Poland, 2016.

Web pages:

- [120] EBU, <http://www3.ebu.ch/home> [Access: 2016-10-10]
- [121] KRRiT, *Norwegia wyłączy FM w 2017 roku*, <http://www.krrit.gov.pl/radio-cyfrowe/aktualnosci/news,1877,norwegia-wylaczy-fm--w-2017-roku.html> [Access: 2016-10-10]
- [122] Polish Radio, *European Radio Forum*, <http://www.polskieradio.pl/Europejskie-Forum-Radiowe/Tag179577> [Access: 2016-10-10]

- [123] Polish Radio, *Współpraca mediów publicznych grupy V4*, <http://www.polskieradio.pl/7/129/Artykul/1670365,Wspolpraca-mediow-publicznych-grupy-V4-Barbara-Stanislawczyk-mamy-wspolne-korzenie> [Access: 2016-10-10]
- [124] QUALINET – COST IC 1003, <http://www.qualinet.eu/> [Access: 2016-10-10]
- [125] UKE, *Porozumienia Genewa 2006 (174-230 MHz oraz 470-862 MHz)*, <https://www.uke.gov.pl/porozumienia-genewa-2006-174-230-mhz-oraz-470-862-mhz-16717> [Access: 2016-10-10]



List of Figures

Fig. 2.1. FFT implementation of OFDM.....	24
Fig. 2.2. DAB+ frame structure.....	26
Fig. 2.3. DAB+ concatenated coding system.....	28
Fig. 2.4. Difference between analog FM and digital DAB+ radio transmission.....	30
Fig. 2.5. DAB+ management link.....	31
Fig. 2.6. AAC codec profile.....	34
Fig. 2.7. AAC encoder.....	34
Fig. 2.8. Objective quality metrics: a) parameter-based, b) signal-based intrusive, c) signal-based non-intrusive.....	41
Fig. 3.1. Generation of the DAB+ multiplex.....	43
Fig. 3.2. Logical structure of the DAB+ multiplex.....	44
Fig. 3.3. Ensemble CU allocation.....	45
Fig. 3.4. Ensemble bitrate assignment.....	45
Fig. 3.5. Subjective quality assessment of real-time DAB+ broadcasted radio programs.....	49
Fig. 3.6. Subjective comparative quality assessment of DAB+ radio programs with respect to simulcasted FM programs.....	50
Fig. 3.7. Subjective quality assessment of new radio programs available on the DAB+ multiplex.....	51
Fig. 3.8. Quality assessment of AAC processed signal samples: a) objective results – musical instruments, b) subjective results – musical instruments, c) objective results – speech and singing, d) subjective results – speech and singing, e) objective results – different music genres, f) subjective results – different music genres, g) objective results – popular music, h) subjective results – popular music.	54
Fig. 3.9. Questionnaire concerning the switchover from analog to digital radio domain: a) factors that would encourage people to buy a new DAB+ radio receiver, b) most important switchover criteria for migrating from analog to digital radio.....	56
Fig. 4.1. The SMOC algorithm.....	60
Fig. 4.2. Block diagram of the content analyzer.....	63
Fig. 4.3. Share of different types of content – primetime: a) Talk 1, b) Arts, c) Talk 2, d) Pop Music, e) Informative EN, f) Informative PL, g) Electronic Music, h) Regional, i) Children.....	66
Fig. 4.4. Share of different types of content – random parts of the day: a) Talk 1, b) Arts, c) Talk 2, d) Pop Music, e) Informative EN, f) Informative PL, g) Electronic Music, h) Regional, i) Children.....	68
Fig. 4.5. PCP coefficient with respect to profile: a) primetime, b) random parts of the day.	70
Fig. 4.6. Block diagram of the SMOC adaptive multiplexing simulator.....	71

Fig. 4.7. Multiplex resource management – primetime: a) MUX 1, b) MUX 2, c) MUX 3, d) MUX 4.....	74
Fig. 4.8. Radio program resource management – primetime: a) Talk 1, b) Arts, c) Talk 2, d) Pop Music, e) Informative EN, f) Informative PL, g) Electronic Music, h) Regional, i) Children.	76
Fig. 4.9. Multiplex resource management – random parts of the day: a) MUX 1, b) MUX 2, c) MUX 3, d) MUX 4.....	77
Fig. 4.10. Radio program resource management – random parts of the day: a) Talk 1, b) Arts, c) Talk 2, d) Pop Music, e) Informative EN, f) Informative PL, g) Electronic Music, h) Regional, i) Children.....	79
Fig. 4.11. Multiplex resource savings: a) primetime, b) random parts of the day.	82
Fig. 4.12. MCF coefficient: a) primetime, b) random parts of the day.	83
Fig. 4.13. Probability of introducing additional services – primetime: a) MUX 1, b) MUX 2, c) MUX 3, d) MUX 4.....	85
Fig. 4.14. Probability of introducing additional services – random parts of the day: a) MUX 1, b) MUX 2, c) MUX 3, d) MUX 4.	86
Fig. 5.1. Block diagram of signal forming in the SMOC DAB+ radio link.....	90
Fig. 5.2. Block diagram of the SMOC adaptive multiplexer.	90
Fig. 5.3. Block diagram of the SMOCmuxPG radio link.....	91
Fig. 5.4. Architecture of USRP B200mini [106].....	92
Fig. 5.5. Block diagram of the transmitting side.	93
Fig. 5.6. Operating SDR-based DAB+ transmitter.	93
Fig. 5.7. Block diagram of the DAB+ transmitter.....	93
Fig. 5.8. Block diagram of the COFDM encoder.....	94
Fig. 5.9. Architecture of the DAB+ receiver.....	94
Fig. 5.10. Operating programmable DAB+ receiver.....	95
Fig. 5.11. DAB+ programmable receiver GUI user interface: a) main menu, b) SLS menu.	96
Fig. 5.12. TechniSat DigitRadio 350 IR receiver: a) frequency info, b) bitrate info.	97
Fig. 5.13. Band III occupancy.	98
Fig. 5.14. Signal spectrum of the SMOCmuxPG DAB+ multiplex.....	98
Fig. 5.15. SMOCmuxPG initial ensemble configuration.....	101
Fig. 5.16. DAB+ receivers tuned in to SMOCmuxPG: a) GUI user interface, b) frequency info, c) bitrate info.	102
Fig. 5.17. FIB Count of SMOCmuxPG.....	103
Fig. 5.18. FIB Error Rate of SMOCmuxPG.....	103
Fig. 5.19. Subjective quality assessment of SMOCmuxPG.....	104

List of Tables

Tab. 2.1. DAB+ transmission modes [43].....	25
Tab. 2.2. MOS grading scale.....	38
Tab. 2.3. MOS ACR grading scale.....	39
Tab. 2.4. MOS CCR grading scale.....	39
Tab. 2.5. MUSHRA grading scale.	39
Tab. 3.1. DAB+ ensemble configuration in Gdańsk (August 2016).....	46
Tab. 3.2. Profile and bitrate of assessed DAB+ radio programs.....	49
Tab. 3.3. Profile and bitrate of assessed new DAB+ radio programs.	51
Tab. 3.4. Audio test signals used in the subjective and objective tests.....	52
Tab. 3.5. ANOVA test results.	53
Tab. 4.1. SMOC content management.	60
Tab. 4.2. Relation between priority and transmitted content.	62
Tab. 4.3. Share of different types of content – primetime.	65
Tab. 4.4. Share of different types of content – random parts of the day.....	67
Tab. 4.5. Relation between weight and type of content.	69
Tab. 4.6. PCP coefficient with respect to profile – primetime.....	70
Tab. 4.7. PCP coefficient with respect to profile – random parts of the day.	70
Tab. 4.8. Basic parameters of the simulated multiplexes.....	73
Tab. 4.9. Multiplex resource savings – primetime.....	81
Tab. 4.10. Multiplex resource savings – random parts of the day.	81
Tab. 4.11. MCF coefficient.	82
Tab. 4.12. Relation between required resources and type of service.....	84
Tab. 4.13. Probability of introducing additional services – primetime.....	84
Tab. 4.14. Probability of introducing additional services – random parts of the day.	84
Tab. 5.1. Features of USRP B200mini.....	92
Tab. 5.2. SMOCmuxPG initial ensemble configuration.....	99
Tab. 5.3. SMOCmuxPG ensemble configuration – step #1.....	100
Tab. 5.4. SMOCmuxPG ensemble configuration – step #2.....	100
Tab. 5.5. SMOCmuxPG ensemble configuration – step #3.....	100
Tab. 5.6. SMOCmuxPG ensemble configuration – step #4.....	100

