

New sample preparation strategies for comprehensive lipidomics of human breast milk

DOROTA GARWOLIŃSKA*, WERONIKA HEWELT-BELKA, JACEK NAMIEŚNIK,
AGATA KOT-WASIK

*Department of Analytical Chemistry, Faculty of Chemistry, Gdansk University of Technology,
11/12 Narutowicza St., 80-233 Gdansk, Poland ✉ dorota.garwolinska@pg.edu.pl*

Keywords

human breast milk
untargeted lipidomics

Abstract

Global profiling analysis of human breast milk lipids is hindered by complex composition of human breast milk. This problem is huge from analytical point of view, since due to that detection of all human breast milk lipids during one analytical run is limited. Thus, sample preparation step constitutes a crucial step in untargeted lipidomic analysis of human breast milk, especially when semi-quantitative analysis is assumed. Herein, we present a comparison of published and proposed by us sample preparation procedures used in lipidomic study of human breast milk, including indication of advantages, drawbacks and possible application.

1. Introduction

Human breast milk is considered as the gold standard in nutrition of the newborn [1]. Despite a huge contribution of human breast milk lipids to the total amount of human breast milk nutrients and their impact on the proper child development, they remain the least understood part of milk. Due to the inefficiency and time-consuming of prior available traditional analytical methods for lipid analysis, the extension of knowledge about human breast milk lipids was limited. The application of untargeted lipidomics that offers investigation of lipids in a fast and precise way allows for detailed characterization of an enormous number of human breast milk lipids species, even those unidentified previously, in one analytical run.

One of the main concerns in untargeted lipidomic study is to achieve high lipidome coverage using simple, reproducible sample preparation strategy and limited number of analytical techniques. In human breast milk, the significant variety in concentration level of lipid species occurs. Some lipid classes are dominant with concentration (μM to mM range) in contrast to other one, which are much less abundant (pM – nM range). This applies primarily for low abundant

glycerophospholipids and sphingophospholipids [2], and compared with glycerophospholipids and sphingophospholipids high abundant glycerolipids [3]. This problem is important from analytical point of view, since due to that detection of all human breast milk lipids during one analytical run is limited. Low abundant lipids require enriching step to break the limit of detection, whereas lipids at high concentration levels frequently require dilution step to avoid saturation of MS signal. Therefore, the proper sample preparation is the crucial step in lipidomics analysis of human breast milk.

2. Experimental

2.1 Reagents and chemicals

LC-MS-grade methanol and HPLC-grade chloroform and hexane were purchased from Merck (Germany), and HPLC-grade 2-propanol, ammonium formate (99.9% purity) formic acid and ammonia p.a were purchased from Sigma-Aldrich (USA). Deionized water was purified on an HLP5 system (Hydrolab, Wiślina, Poland).

2.2 Sample preparation procedure

For the global lipidomics of human breast milk we developed two sample preparation protocols. First one has been based on solid-phase microextraction (SPME) technique [4] and the second one involves combination of solid-phase extraction (SPE) and liquid-liquid extraction (LLE) techniques [5]. The flowcharts of sample preparation strategies for global lipidomic of human breast milk are presented on Fig. 1 and 2 respectively.

The first sample preparation protocol was described in details in previous research [4]. In short, prior to adsorption, the SPME tip that consisted of a fiber coated with a silica-based sorbent modified with C18 groups (Supelco, Sigma-Aldrich, USA) was preconditioned in a mixture of solvents (MeOH/H₂O). Then, it

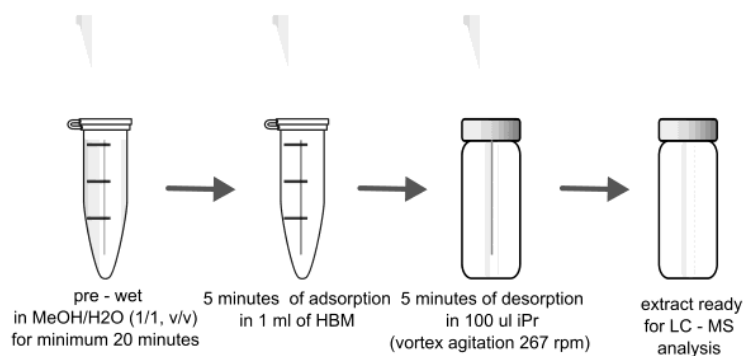

Fig. 1 Optimized protocol for human breast milk lipid extraction using SPME technique [4].

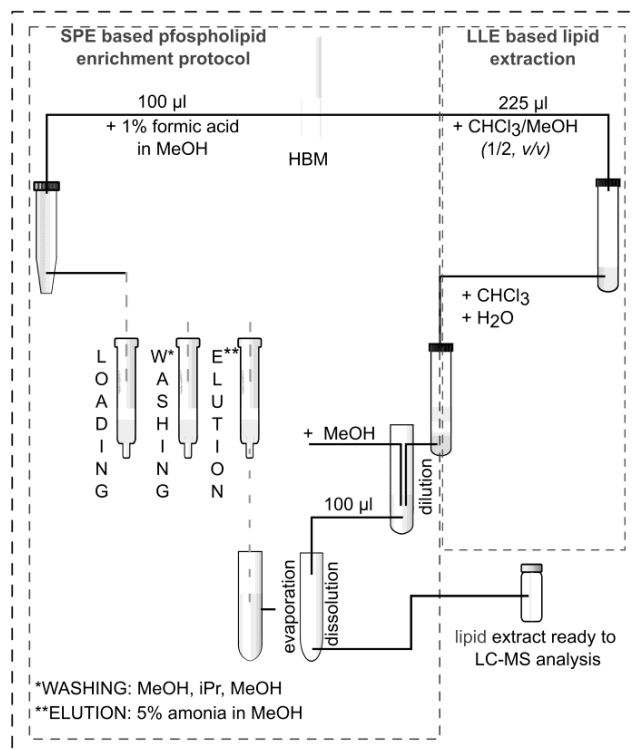

Fig. 2 Lipid extraction by SPE and LLE based approach [5].

was immersed in 1 mL of human breast milk. After lipid adsorption, the SPME tip was transferred to a LC vial containing a glass insert filled with 2-propanol for lipid desorption. After desorption with shaking, the SPME tip was removed. The obtained lipid extract was subsequently analyzed using LC-Q-TOF-MS.

The second developed sample preparation strategy for comprehensive characterization of human breast milk lipids with used LLE and SPE technique [5] included two basis steps:

1. SPE based phospholipids enrichment: 100 μL of human breast milk sample has to be mixed with the solution of 1% formic acid in methanol and subsequently vigorous vortexing and centrifuged in order to precipitate proteins. Next supernatant has to be loading to the HybridSPE-Phospholipid cartridge (Supelco, Sigma Aldrich, USA). After stationary phase washing, phospholipids can be eluted with 5% ammonia in methanol. The obtained extract has to be evaporated to dryness and dissolved with the use of lipid extract obtained in the second step of sample preparation procedure.
2. LLE based lipid extraction, where just 225 μL of human breast milk sample has to be mixed with the chloroform/methanol mixture and vortexed. Next, appropriate volume of chloroform and water has to be added and after vigorous vortexing sample has to be centrifuged to separate aqueous and organic

phase. The lower organic phase containing lipids has to be diluted and next, 100 μL of diluted extract has to be used as a dissolving solution for enriched phospholipid fraction (obtained in the first step).

Finally, the prepared human breast milk lipid extract can be transferred to the chromatographic vial and analysed by LC-Q-TOF-MS

2.3 Instrumentation

The RP-LC-Q-TOF-MS analysis of obtained extract was performed using Agilent 1290 LC system equipped with a binary pump, an online degasser, an autosampler and thermostated column compartment coupled with a 6540 Q-TOF-MS with a Dual electrospray ionization (ESI) source (Agilent Technologies, USA).

Lipid extracts obtained by SPME based strategy were chromatographically separated on an Agilent ZORBAX SB-C18 column (50 \times 2.1 mm, 1.8 μm particle size) in the condition described in details in previous research [4].

To reduce time of analysis lipid extracts obtained by SPE and LLE based strategy were chromatographically separated on a reversed-phase column (Poroshell 120 EC-C8, 150 \times 2.1 mm, 1.9 μm particle size, Agilent) with a 0.2 μm in-line filter. The column and autosampler temperature throughout the analysis were maintained at 45 $^{\circ}\text{C}$ and 4 $^{\circ}\text{C}$, respectively.

In both cases the injection volume was 0.5 μL and mobile phase consisted of mixture of 5 mM ammonium formate in water and methanol (1:4, v/v) as component A and a mixture of 5 mM ammonium formate in water, hexane and 2-propanol (1:20:79, v/v/v) as component B). The mobile phase was pumped at 0.5 mL min^{-1} within a total run time of 30.5 min. The gradient elution program was initiated with 10% eluent B during the first 10 minutes and was then ramped from 10% to 50% B from 10 to 15 minutes and 50% to 100% B from 15 to 20 minutes. Then, after 0.5 minute, the gradient was switched to 10% eluent B for 10 min for equilibration prior to the next run.

The ESI source condition and data analysis parameters were described in details elsewhere [8].

3. Results and discussion

Human breast milk lipid analysis is hindered by huge diversity of this compounds and their wide range of concentration. Due to that the sample preparation step is crucial. According to available literature data, previously reported methods for human breast milk lipid analysis by HPLC-MS approach including LLE [6] and single phase extraction [6], [7] as sample preparation step. We developed two another methods for lipid extraction, one based on SPME technique, and second one based on SPE and LLE techniques.

Sample preparation method, based on SPME technique allows for rapid and simple comprehensive characterization of lipids in human breast milk samples.



Our sample preparation method offers significant improvements over other published methods for human breast milk lipid extraction. It does not require protein precipitation (extraction is performed directly from human breast milk samples), what minimizes sample preparation step time and significantly reduces the organic solvents use. Moreover, the development of a SPME method in combination with LC-Q-TOF-MS enables detection of broad range of human breast milk lipids. Comparison of the individual lipid classes extracted from human breast milk using different extraction procedures revealed that all extraction procedures provide similar lipidome coverage [4]. However, due to the low precision it can be only use for qualitative purpose. The relative standard deviation of the 69% of molecular feature volumes (detected in three extraction replicates of the same human breast milk sample) was higher than 20%, which does not meet the criteria for semi-quantitative analysis. We assumed that main reason of low precision of develop extraction method, may be high level of glycerolipids concentration, which can cause nonlinear isotherm. Sample dilution may improve precision of extraction procedure, but low level of concentration of some other lipids, limits it. Moreover, due to the wide concentration range of different lipid classes in the human breast milk samples, the MS signal obtained for some of lipids was saturated and required dilution for quantification, and the MS signals for other lipid classes were very low and limit dilution. Thus, the simultaneous quantification of all detected lipid classes in one analytical run was limited also for this reason. However, in our study we focused on developed method for rapid qualitative analysis and for this purpose, developed sample preparation method, even with low repeatability, is sufficient.

To overcome drawbacks of previously evaluated method, we have developed sample preparation method, based on SPE and LLE techniques. The combination of these two extraction techniques enables the enrichment of low abundant human breast milk lipids containing the phosphate moiety (glycerophospholipids and sphingomyelins), and dilution of human breast milk lipids that are at the high concentration level in human milk (glycerolipids). To confirm usefulness of developed lipid extraction protocol the human breast milk lipid chromatograms obtained with the previous and developed method are presented on Fig. 3.

The lipidome coverage obtained by implementation of this enrich-dilute strategy was higher than those described in previously reports [8, 10, 11], particularly in the term of phospholipids content (approximately fourfold more human breast milk lipids containing phosphate moiety were identified. This extraction procedure enables both highly effective separation of phospholipids and glycerolipids. Thus, the developed sample preparation strategy represents valuable tool for comprehensive analysis of human breast milk lipids.



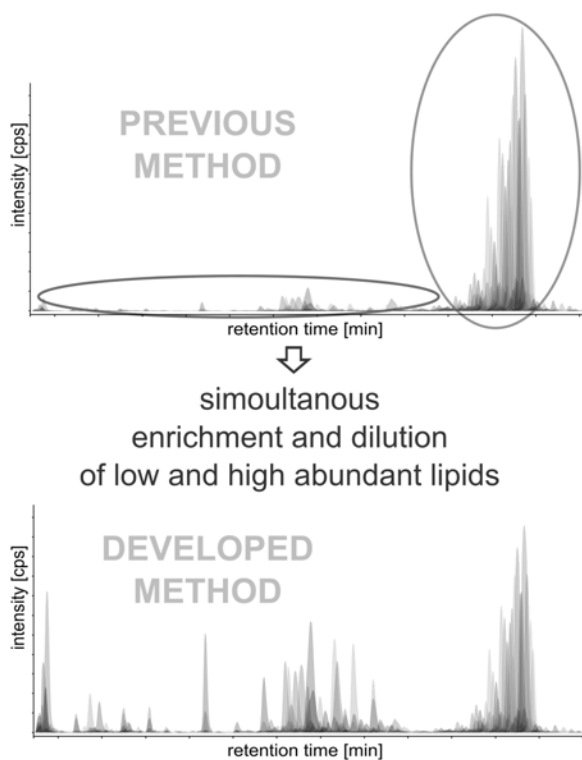

Fig. 3 Lipid chromatograms obtained with the previous and developed method based on SPE and LLE and LC-MS techniques.

4. Conclusions

Preparation of human breast milk sample to lipid analysis performed in untargeted manner is a challenge. Many of available lipid extractions are not suitable for isolation of human breast milk lipids, due to the huge diversity of these compounds and their wide range of concentration. We have developed two sample preparation procedures and compared them with other sample preparation strategies used in analysis of human breast milk lipids. One of them ensures similar lipid coverage to those described in previous reports, but is not suitable for quantitative analysis. However, the second one provides higher lipid coverage than those described in previous reports and is suitable for both qualitative and semi-quantitative lipid analysis performed in untargeted manner.

References

- [1] World Health Organization: *Global strategy for infant and young child feeding*. UNICEF 2003.
- [2] Tavazzi I, Fontannaz P, Lee L.Y., Giuffrida F: Quantification of glycerophospholipids and sphingomyelin in human milk and infant formula by high performance liquid chromatography coupled with mass spectrometer detector. *J. Chromatogr. B* **1072** (2018), 235–243.
- [3] Sokol E, Ulven T, Færgeman N.J., Ejsing C.S.: Comprehensive and quantitative profiling of lipid species in human milk, cow milk and a phospholipid-enriched milk formula by GC and MS/MS(ALL). *Eur. J. Lipid Sci. Technol.* **117** (2015), 751–759.



- [4] Garwolińska D., Hewelt-Belka W., Namieśnik J., Kot-Wasik A.: Rapid Characterization of the human breast milk lipidome using a solid-phase microextraction and liquid chromatography-mass spectrometry-based approach. *J. Proteome Res.* **16** (2017), 3200–3208.
- [5] Hewelt-Belka W., Garwolińska D., Belka M., Bączek T., Namieśnik J., Kot-Wasik A.: *unpublished data*.
- [6] Andreas N.J. Hyde M.J., Gomez-Romero M., Lopez-Gonzalvez M.A., Villaseñor A., Wijeysekera A., Barbas C., Modi N., Holmes E., Garcia-Perez I.: Multiplatform characterization of dynamic changes in breast milk during lactation. *Electrophoresis* **36** (2015), 2269–2285.
- [7] Villaseñor A., Garcia-Perez I., Garcia A., Posma J.M., Fernández-López M., Nicholas A.J., Modi N., Holmes E., Barbas C.: Breast milk metabolome characterization in a single-phase extraction, multiplatform analytical approach. *Anal. Chem.* **86** (2014), 8245–8252.