

Constant vs. Variable Efficiency of Electric Drive in Train Run Simulations

Aleksander Jakubowski
 Faculty of Electrical and Control Engineering
 Gdansk University of Technology
 Gdansk, Poland
 aleksander.jakubowski@pg.edu.pl

Leszek Jarzebowicz
 Faculty of Electrical and Control Engineering
 Gdansk University of Technology
 Gdansk, Poland
 leszek.jarzebowicz@pg.edu.pl

Abstract—Train run simulations, which focus on various power- and energy-oriented aspects, should reflect the losses in the electric powertrain. In general, the powertrain efficiency varies with respect to load and speed. Including this relation in simulation requires knowledge about detailed drivetrain parameters, which are often unavailable. This paper verifies the possibility to approximate the drivetrain efficiency in train run simulations by an equivalent constant that provides the same results of total energy usage. A case study of a suburban electric traction unit was selected to compare results of simulations carried out for different operating conditions including: route length, cruising speed and route inclination. The impact of replacing the variable efficiency with the equivalent constant on various outcomes of train run simulations was discussed and the limitations were formulated.

Keywords—drive efficiency, train run simulation, induction motor drive, electric vehicle, railway transportation

I. INTRODUCTION

Ecological and economic concerns related to transportation lead to increased interest in vehicle energy consumption. Numerous studies on this topic have been carried out recently and a substantial part of them is focused on railway electric vehicles. These studies have various goals [1][2][3][4][5], e.g. optimization of driving style or timetable concerning energy consumption, feasibility studies related to investment in new vehicles, verification of compliance to technical specification of a contract, evaluating the gain from installing storages for regenerative braking energy etc.

The most reliable analysis of energy consumption may be obtained experimentally by recording vehicle parameters during test rides [6]. Nevertheless, in case of railway vehicles, arranging such rides is technically difficult and expensive. Moreover, the common aim of the energy usage studies is to analyze a hypothetical scenario, which includes technical improvements in vehicles or infrastructure that are yet under consideration. If the analysis consists of conceptual solutions, the experimental approach is not applicable.

Due to the problems mentioned above, train run simulations are a convenient and commonly used tool for estimating train power and energy usage. Besides vehicle dynamics, such simulations must include all the important factors related to energy losses like vehicle resistive forces or efficiency of the drivetrain. In general, the drivetrain efficiency varies with respect to the operating point, which may be reflected in the train run simulations. Nevertheless,

modeling the variable efficiency requires knowledge of detailed drivetrain parameters. In practice, such parameters are commonly unknown, which leads to necessary simplifications. If the level of parameters uncertainty is high, it may be reasonable to roughly approximate the efficiency with a constant value [7].

This paper verifies the accuracy of approximating the drivetrain efficiency in train run simulations by a constant. The analysis is carried out for a suburban electric traction unit. Based on train run simulations that include variable efficiency, equivalent constant efficiencies that provide the same energy consumption were derived. The simulations were repeated for different travelling distances, train cruising speeds and route inclinations, in order to investigate how these factors influence the value of equivalent efficiency. Additionally, the impact of using the equivalent efficiency on other important outcomes of the train run such as regenerative energy or peak current usage were discussed.

II. TRAIN RUN SIMULATION

The general structure of the train run simulation model is presented in Fig. 1.

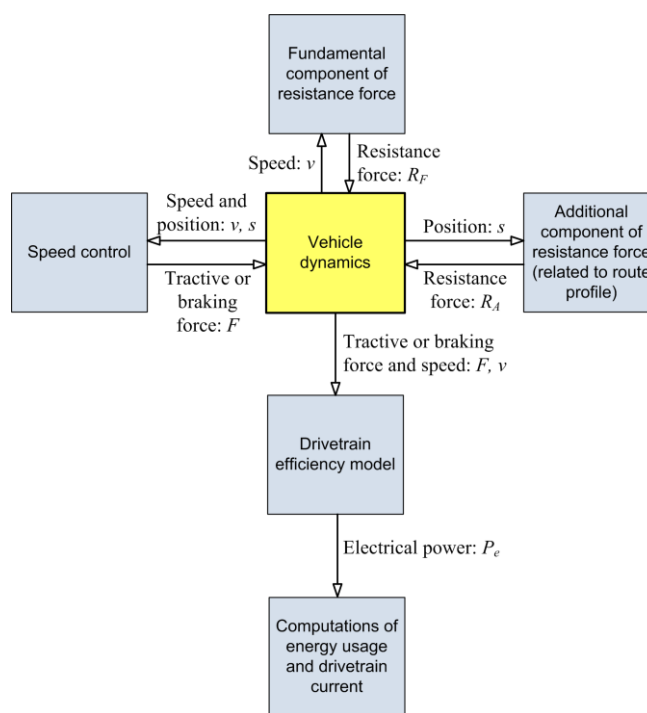

Fig. 1. Block diagram of a train run simulation model

This scientific work is financed from resources for science as a Research Project of the National Centre for Research and Development under the agreement POIR.01.02.00-00-0193/16-00.

The main part of the model includes the equation of vehicle dynamics:

$$a = \frac{F - R_F - R_A}{k \cdot m} \quad (1)$$

where: a is the train acceleration; F is tractive or braking force generated by the electric drive; R_F and R_A are fundamental and additional resistance forces, respectively; m is the vehicle mass; k is a mass correction factor.

The resistive force consists of two components. The fundamental component R_F represents the air drag and friction forces that are associated with train velocity. They are approximated by a quadric function of the velocity. The additional component R_A of resistance force reflects the friction related to running on curves and the longitudinal component of the gravity force, which becomes non-zero when running on slopes. The mass correction factor k aims at including the impact of rotating elements whose angular speed is related to the linear velocity, i.e. including their moment of inertia in the equation that describes the linear motion. Whilst the vehicle dynamics equation (1) computes vehicle acceleration a , the velocity and distance covered by the vehicle is computed by a single and double integration of a , respectively.

The tractive or braking force F is set by a speed controller, based on an assumed speed profile. The force F is limited to the range determined by rated torque and speed of the electric drivetrain.

Based on force F and velocity v , the mechanical power is computed as $P = F \cdot v$. This power is next divided by the drivetrain efficiency $\eta = f(F; v)$ in order to derive the electrical power P_e at the input of the electric drive. The details on modeling the efficiency are given in the next section. The electrical energy usage is computed by integrating the electrical power P_e . The input current I is computed by dividing the power by a constant supplying voltage. Auxiliary loads and friction brakes are not reflected in the model.

III. TRAIN PARAMETERS

The modeled vehicle is an electric traction unit designed for suburban service. Its parameters, listed in Table I, were selected to represent a typical setup of suburban trains. The vehicle is equipped with four induction motors, each rated at 500 kW. The motors are grouped in pairs, and each pair is fed by an IGBT inverter.

TABLE I. MAIN PARAMETERS OF THE MODELED TRAIN

Parameter	Value
Mechanical power	2 MW
Supply voltage	3 kV
Maximal acceleration	1 m/s ²
Net weight	150 t
Maximal weight of passengers	20 t
Number of seats	250
Coefficients of fundamental resistance force quadric equation	1879 N, 20,470 N/(km/h), 0.772 N/(km ² /h ²)
Length/width/height	80.00 m / 2.84 m / 4.15 m

IV. DRIVETRAIN EFFICIENCY MODELING

The drivetrain efficiency model, included in Fig. 1, can operate in two modes. The simplified mode uses a constant value of efficiency, while the detailed mode reflects the varying efficiency that depends on the operating conditions.

Numerous references report on comprehensive models that allow for accurate computation of losses both in power converter and in electric motor [8][9][10]. However, execution of such models requires short step size of the numerical solver in order to reflect transients related to voltage modulation. Train run simulations use step sizes determined by vehicle dynamics, which are a few orders of numbers higher. Therefore, including the comprehensive drivetrain models into train run simulations would introduce computation-related problems. These problems may be omitted either by approximating the losses by empirical equations or by using the comprehensive models offline to derive efficiency look-up tables in advance to vehicle run simulations [11][12].

The proposed model uses a look-up table to represent the variable efficiency of the induction motors and an empirical equation to estimate the losses in the power converters.

A. Electric motor efficiency

The efficiency look-up table for the induction motor was derived based on the equivalent circuit of the motor [13]. The self- and mutual inductances, as well as stator- and rotor resistances were provided by the motor manufacturer. The equivalent circuit was complimented by the mechanical equation to form a comprehensive model of induction motor.

The motor model was used to derive the efficiency in steady state conditions, i.e. under constant speed and torque. The efficiency was computed based on the electrical power derived from stator voltage and current, and the output power computed based on the rotor speed and mechanical torque (Fig. 2). In order to set a certain operating point at the torque-vs-speed chart, the speed controller and the mechanical load subsystems were introduced.

The efficiency look-up table was derived by performing numerous simulations, where different motor speeds and load torque were set in short steps. The results are presented graphically in Fig. 3.

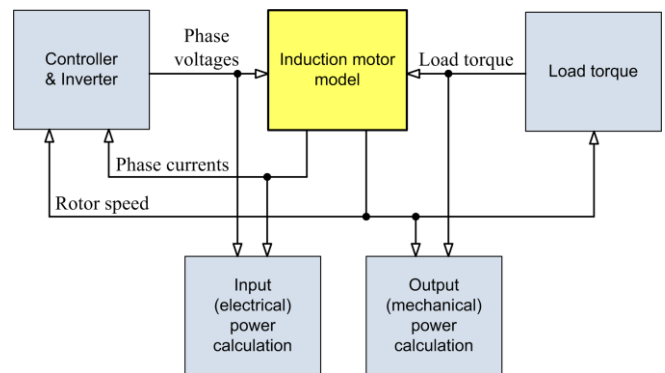

Fig. 2. Block diagram of a model used for deriving the look-up table of motor efficiency

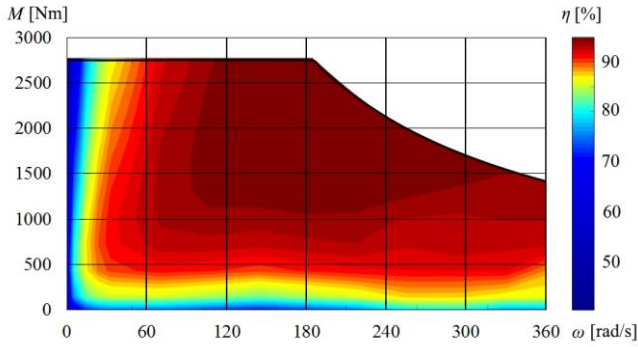

Fig. 3. Graphical presentation of the look-up table representing the efficiency of an induction motor

B. Inverter efficiency

The power losses in the inverter were divided into four components: transistors switching losses $P_{T_{sw}}$, transistors conduction losses $P_{T_{cond}}$, diodes reverse-recovery losses $P_{T_{rec}}$ and diodes conduction losses $P_{D_{cond}}$ [14].

The switching losses in a single transistor were estimated as:

$$P_{T_{sw}} = \frac{U_{DC}}{U_{DCn}} \cdot (E_{sw(on)} + E_{sw(off)}) \cdot \frac{f_{sw}}{\pi} \quad (1)$$

where: U_{DC} – DC bus voltage; U_{DCn} – nominal DC bus voltage; f_{sw} – switching frequency; $E_{sw(on)}$, $E_{sw(off)}$ – energy dissipated during turn-on and turn-off, respectively, which are given as a function of collector current for $U_{DC} = U_{DCn}$ (available in power module datasheet).

The conduction losses in an IGBT transistor were approximated using the following equation:

$$P_{T_{cond}} = I_C \cdot U_{CE} \cdot \left(\frac{1}{8} + \frac{D \cdot \cos \varphi}{3\pi} \right) \quad (2)$$

where: I_C – collector current; U_{CE} – collector-emitter saturation voltage being a function of I_C ; D – duty cycle; $\cos \varphi$ – power factor of the motor.

The reverse-recovery losses in a free-wheeling diode were modeled as:

$$P_{D_{rec}} = \frac{U_{DC}}{U_{DCn}} \cdot E_{rec} \cdot \frac{f_{sw}}{\pi} \quad (3)$$

where: E_{rec} – energy dissipated due to reverse recovery charge current, which are given as a function of collector.

The power losses related to the forward voltage drop on a diode are given by:

$$P_{D_{cond}} = I_C \cdot U_F \cdot \left(\frac{1}{8} - \frac{D \cdot \cos \varphi}{3\pi} \right) \quad (4)$$

where: U_F – forward voltage being a function of I_C .

As equations (1)–(4) consider losses in a single transistor or diode, the total losses can be computed as:

$$P_{inv_loss} = 6 \cdot (P_{T_{sw}} + P_{T_{cond}} + P_{D_{rec}} + P_{D_{cond}}) \quad (5)$$

V. TRAIN RUN SIMULATIONS

The train run model from Fig. 1 was implemented in Simulink simulation software in order to compare results obtained for variable and for constant drivetrain efficiency. The train run simulations were carried out using a trapezoidal speed profile, which consists of the following stages: accelerating, running with constant velocity (cruising), and regenerative braking [15]. Parameters of the run, such as cruising speed, travelling distance and route inclination were differentiated including the following variants:

- cruising velocity: 80 km/h (normal) or 40 km/h (reduced);
- travelling distance between stops: 1 km (normal) or 5 km (long);
- route inclination: 0‰, +5‰, -5‰;

In addition to the route inclination variants listed above, a case of running both ways on the same route inclined at +5‰ was investigated. The aim of this investigation was to verify if the resulting equivalent efficiency is similar to the one obtained for the horizontal route.

For every possible set of the above-listed parameters, train runs were performed twice. First run, being a reference one, was carried out using the variable drivetrain efficiency. Second run included constant (equivalent) efficiency, whose value was selected to match the final energy usage from the first run. For each pair of runs, a summary was prepared consisting of: consumed and regenerative energy, maximal current and mean current. These parameters are considered important for comprehensive design of the supply system, e.g. rating the transformers and rectifiers, setting overcurrent threshold in the circuit breakers, rating supercapacitor storages etc.

Waveforms including results of both variable and equivalent efficiency for the case of travelling at normal distance, with normal cruising velocity, and no route inclination are shown in Fig. 4. The speed profiles are identical for both variants of efficiency modeling (Fig. 4a). Due to relatively short distance, duration of the run is dominated by acceleration and braking intervals. The stage of cruising takes less than 10 s out of total running time of 72 s. The equivalent efficiency is close to the maximal value of the variable one (Fig. 4b). Differences in drivetrain current and in the energy usage are minor, as shown in Fig. 4c and Fig. 4d, respectively.

The summary of all train runs was grouped with respect to route length and cruising velocity and included in Tables I-IV. Table I consists of results corresponding to running with normal speed and on normal distance. The equivalent efficiencies are in the range between 82.0% and 82.9%, depending on the route inclination. The differences between the compared energies and currents are minor and do not exceed 1%. Hence, the possibility to approximate the variable efficiency with constant equivalent is well justified here.

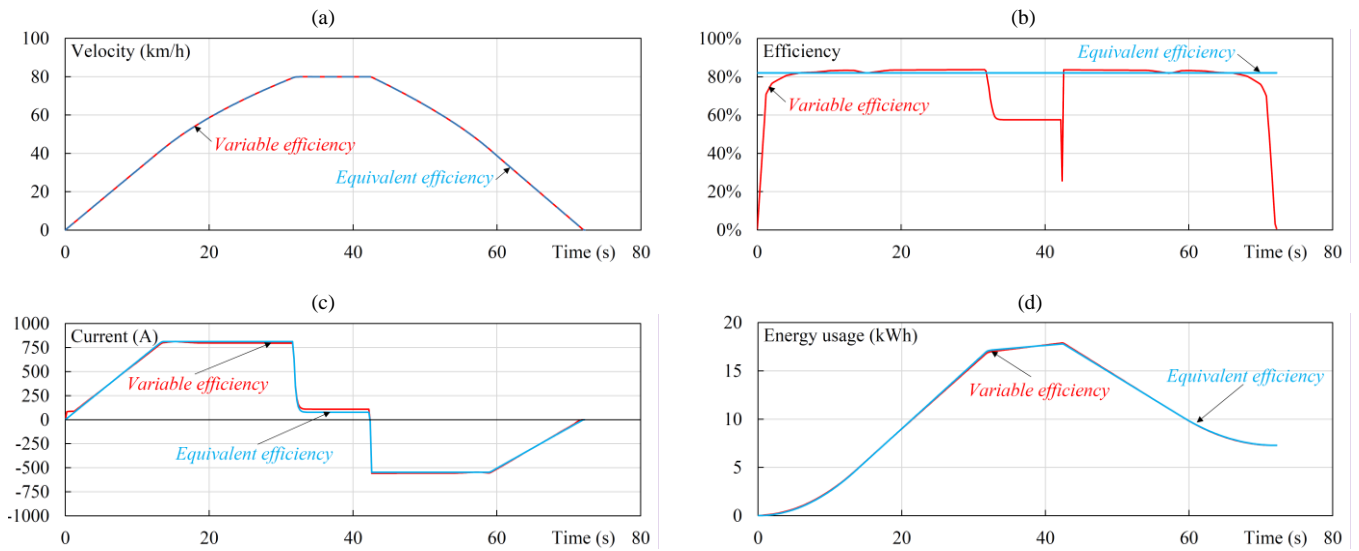

Fig. 4. Train run waveforms for normal travelling distance, normal running speed and horizontal route profile: (a) train velocity; (b) drivetrain efficiency; (c) drivetrain current; (d) drivetrain energy usage

TABLE I. TRAIN RUN RESULTS FOR NORMAL TRAVELLING DISTANCE AND NORMAL RUNNING SPEED

Inclination	Results for distance $s = 1$ km and speed $v = 80$ km/h			
	Parameter	Value for variable efficiency	Value for equivalent efficiency	Relative difference
$i = 0\%$	Efficiency	var.	82.0 %	–
	Final energy usage	7.3 kWh	7.3 kWh	0%
	Consumed energy	17.9 kWh	17.8 kWh	-1%
	Regenerative energy	-10.6 kWh	-10.5 kWh	-1%
	Mean current	474 A	470 A	-1%
	Maximal current	813 A	813 A	0%
$i = 5\%$	Efficiency	var.	82.3 %	–
	Final energy usage	9.7 kWh	9.7 kWh	0%
	Consumed energy	19.7 kWh	19.6 kWh	0%
	Regenerative energy	-10.0 kWh	-9.9 kWh	-1%
	Mean current	493 A	491 A	0%
	Maximal current	813 A	810 A	0%
$i = -5\%$	Efficiency	var.	82.9 %	–
	Final energy usage	4.9 kWh	4.9 kWh	0%
	Consumed energy	16.2 kWh	16.1 kWh	-1%
	Regenerative energy	-11.3 kWh	-11.2 kWh	-1%
	Mean current	457 A	453 A	-1%
	Maximal current	813 A	814 A	0%
Joint $i = 5\%$ and $i = -5\%$	Efficiency	var.	82.1 %	–
	Final energy usage	14.6 kWh	14.6 kWh	0%
	Consumed energy	35.9 kWh	35.7 kWh	-1%
	Regenerative energy	-21.3 kWh	-21.1 kWh	-1%
	Mean current	477 A	474 A	-1%
	Maximal current	813 A	814 A	0%

TABLE II. TRAIN RUN RESULTS FOR NORMAL TRAVELLING DISTANCE AND REDUCED RUNNING SPEED

Inclination	Results for distance $s = 1$ km and speed $v = 40$ km/h			
	Parameter	Value for variable efficiency	Value for equivalent efficiency	Relative difference
$i = 0\%$	Efficiency	var.	75.1%	–
	Final energy usage	3.3 kWh	3.3 kWh	0%
	Consumed energy	6.0 kWh	5.8 kWh	-4%
	Regenerative energy	-2.7 kWh	-2.5 kWh	-8%
	Mean current	102 A	97 A	-5%
	Maximal current	739 A	820 A	11%
$i = 5\%$	Efficiency	var.	78.2%	–
	Final energy usage	5.9 kWh	5.9 kWh	0%
	Consumed energy	8.4 kWh	8.3 kWh	-1%
	Regenerative energy	-2.6 kWh	-2.4 kWh	-4%
	Mean current	128 A	126 A	-2%
	Maximal current	747 A	797 A	7%
$i = -5\%$	Efficiency	var.	77.8%	–
	Final energy usage	0.7 kWh	0.7 kWh	0%
	Consumed energy	4.0 kWh	4.2 kWh	4%
	Regenerative energy	-3.3 kWh	-3.5 kWh	5%
	Mean current	86 A	90 A	5%
	Maximal current	737 A	791 A	7%
Joint $i = 5\%$ and $i = -5\%$	Efficiency	var.	78.0%	–
	Final energy usage	6.5 kWh	6.5 kWh	0%
	Consumed energy	12.4 kWh	12.5 kWh	1%
	Regenerative energy	-5.9 kWh	-5.9 kWh	1%
	Mean current	107 A	108 A	1%
	Maximal current	747 A	797 A	7%

TABLE III. TRAIN RUN RESULTS FOR LONG TRAVELLING DISTANCE AND NORMAL RUNNING SPEED

Inclination	Results for distance $s = 5$ km and speed $v = 80$ km/h			
	Parameter	Value for variable efficiency	Value for equivalent efficiency	Relative difference
$i = 0\%$	Efficiency	var.	72.8 %	–
	Final energy usage	23.6 kWh	23.6 kWh	0%
	Consumed energy	34.2 kWh	32.9 kWh	-4%
	Regenerative energy	-10.6 kWh	-9.3 kWh	-12%
	Mean current	213 A	201 A	-6%
	Maximal current	813 A	916 A	13%
$i = 5\%$	Efficiency	var.	76.7 %	–
	Final energy usage	36.1 kWh	36.1 kWh	0%
	Consumed energy	46.1 kWh	45.3 kWh	-2%
	Regenerative energy	-10.0 kWh	-9.2 kWh	-7%
	Mean current	267 A	260 A	-3%
	Maximal current	813 A	869 A	7%
$i = -5\%$	Efficiency	var.	67.6 %	–
	Final energy usage	10.4 kWh	10.4 kWh	0%
	Consumed energy	21.7 kWh	19.7 kWh	-10%
	Regenerative energy	-11.3 kWh	-9.3 kWh	-18%
	Mean current	157 A	138 A	-13%
	Maximal current	813 A	986 A	21%
Joint $i = 5\%$ and $i = -5\%$	Efficiency	var.	73.5 %	–
	Final energy usage	46.5 kWh	46.5 kWh	0%
	Consumed energy	67.8 kWh	65.4 kWh	-4%
	Regenerative energy	-21.3 kWh	-18.9 kWh	-11%
	Mean current	212 A	201 A	-5%
	Maximal current	813 A	986 A	12%

TABLE IV. TRAIN RUN RESULTS FOR LONG TRAVELLING DISTANCE AND REDUCED RUNNING SPEED

Inclination	Results for distance $s = 5$ km and speed $v = 40$ km/h			
	Parameter	Value for variable efficiency	Value for equivalent efficiency	Relative difference
$i = 0\%$	Efficiency	var.	57.5%	–
	Final energy usage	13.3 kWh	13.3 kWh	0%
	Consumed energy	16.0 kWh	15.2 kWh	-5%
	Regenerative energy	-2.7 kWh	-1.9 kWh	-30%
	Mean current	48 A	44 A	-9%
	Maximal current	739 A	1071 A	45%
$i = 5\%$	Efficiency	var.	74.5%	–
	Final energy usage	24.7 kWh	24.7 kWh	0%
	Consumed energy	27.3 kWh	27.0 kWh	-1%
	Regenerative energy	-2.6 kWh	-2.3 kWh	-9%
	Mean current	77 A	76 A	-2%
	Maximal current	747 A	837 A	12%
$i = -5\%$	Efficiency	var.	68.1%	–
	Final energy usage	-1.6 kWh	-1.6 kWh	0%
	Consumed energy	4.0 kWh	4.8 kWh	19%
	Regenerative energy	-5.6 kWh	-6.4 kWh	14%
	Mean current	25 A	29 A	15%
	Maximal current	737 A	903 A	22%
Joint $i = 5\%$ and $i = -5\%$	Efficiency	var.	72.7%	–
	Final energy usage	23.1 kWh	23.1 kWh	0%
	Consumed energy	31.2 kWh	32.2 kWh	3%
	Regenerative energy	-8.2 kWh	-9.1 kWh	11%
	Mean current	51 A	53 A	5%
	Maximal current	747 A	903 A	15%

Table II includes results of running with reduced speed on the same distance as in Table I. The differences between the equivalent efficiencies are greater than that for the normal travelling distance, as they range from 75.1% to 78.0%. The efficiencies are lower than in Table I, which is related to lighter load resulting from cruising with reduced velocity. The notable differences appear between energies and currents derived for the two efficiency-modeling modes. However, with one exception, these differences do not exceed 10%. For this case, selecting the constant efficiency provides ultimate approximation of the results.

Table III presents results of running with normal speed on a long distance. The differences between the equivalent efficiencies are substantial and range from 67.6% to 76.7%. This results from extended interval corresponding to running with constant velocity, where the variable efficiency is determined by the load related to route inclination. Additionally, high differences appear in comparison of energies and currents. The highest difference of 21% corresponds to the maximal current for the downhill run. In this run, the regenerated energy computed with equivalent

efficiency is underestimated by nearly 20%. Concluding, the modeling precision for the equivalent efficiency is not satisfactory here.

Table IV includes a summary of runs carried out for long travelling distance and reduced speed. The results of the run at horizontal route are also presented graphically in Fig. 5. As shown in Fig. 5a, the stage of running with constant velocity dominates the simulation time. As this stage corresponds to low efficiency of the drivetrain, the equivalent efficiency is less than 60% (Fig. 5b). Hence, the instantaneous differences between the equivalent and variable efficiency occur during cruising as well as during accelerating and braking. Consequently, the use of equivalent efficiency leads to overestimating the current during acceleration and to underestimating it during coasting and braking. Despite of equal final energy usages, the differences in other parameters included in the summary are substantial. The maximal current differs by 45% and the regenerative energy by 30%. Such differences disqualify the use of equivalent energy in case of long travelling distances and low speeds.

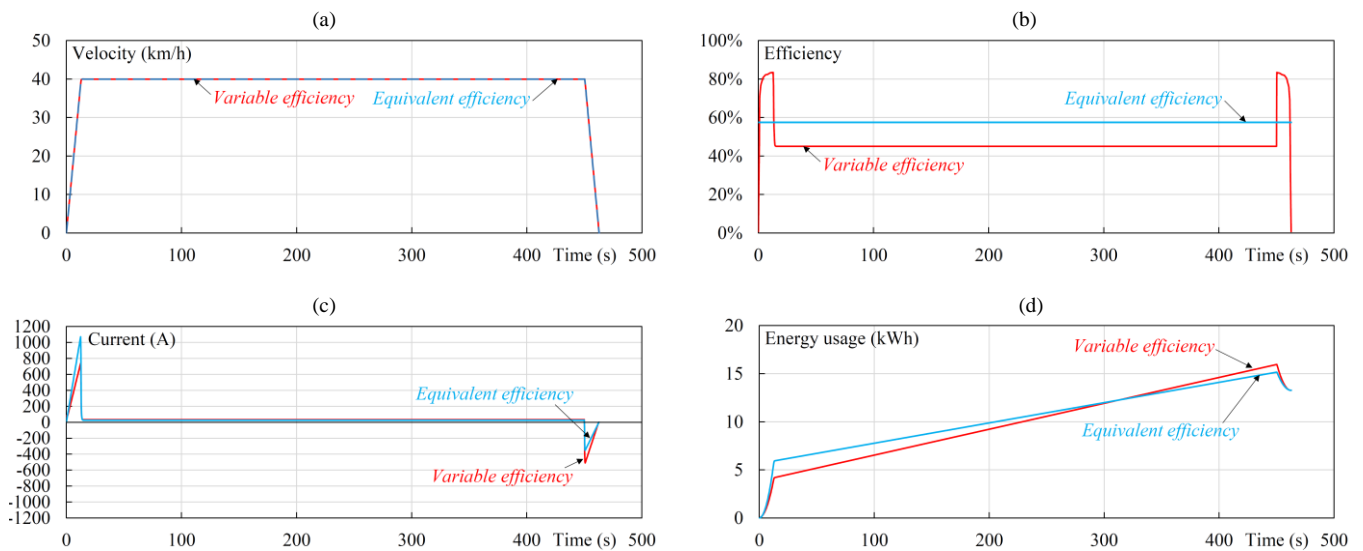

Fig. 5. Train run waveforms for long travelling distance, reduced running speed and horizontal route profile: (a) train velocity; (b) drivetrain efficiency; (c) drivetrain current; (d) drivetrain energy usage

VI. CONCLUSION

The analysis carried out in the paper investigates the accuracy of using the equivalent efficiency in train run simulations. The results show that using the equivalent efficiency provides accurate results only for train run scenarios, where the drivetrain operates with high load for the most of the run time. This applies to short distances between stops or running on steep routes. It is also expected that the runs that use coasting instead of cruising would be modeled by the equivalent efficiency quite accurately.

It was proven that selecting the value of equivalent efficiency by using the criterion of true final energy usage results in errors of other train run outcomes such as regenerative energy or maximal current. This makes the use of equivalent efficiency in multi-criterial analyses questionable.

As using the equivalent efficiency makes the results uncertain, it should be avoided in analyses aimed at deriving specific parameters of a run. However, it may be ultimately used for investigating the general dependencies, e.g. the impact of modifying the velocity profile on regenerative or final energy usage. Hence, it can be concluded that using the constant drivetrain efficiency is more appropriate for qualitative than quantitative analyses.

REFERENCES

- [1] M. Bartłomiejczyk, "Driving Performance Indicators of Electric Bus Driving Technique: Naturalistic Driving Data Multicriterial Analysis," *IEEE Transactions on Intelligent Transportation Systems*, early access, 2018.
- [2] Y. Zhou, Y. Bai, J. Li, B. Mao, and T. Li, "Integrated Optimization on Train Control and Timetable to Minimize Net Energy Consumption of Metro Lines," *Journal of Advanced Transportation*, 2018.
- [3] A. Hoffrichter, J. Silmon, F. Schmid, S. Hillmannsen, and C. Roberts, "Feasibility of discontinuous electrification on the Great Western Main Line determined by train simulation," *Proceedings of the Institution of Mechanical Engineers, Part F: Journal of Rail and Rapid Transit*, vol. 227, no. 3, pp. 296–306, May 2013.
- [4] Z. Jia, Z. Yang, F. Lin, and X. Fang, "Dynamic simulation of the DC traction power system considering energy storage devices," in *2014 IEEE Conference and Expo Transportation Electrification Asia-Pacific (ITEC Asia-Pacific)*, 2014, pp. 1–6.
- [5] A. Frilli, E. Meli, D. Nociolini, L. Pugi, and A. Rindi, "Energetic optimization of regenerative braking for high speed railway systems," *Energy Conversion and Management*, vol. 129, pp. 200–215, Dec. 2016.
- [6] R. Thijssen, T. Hofman, and J. Ham, "Ecodriving acceptance: An experimental study on anticipation behavior of truck drivers," *Transportation Research Part F: Traffic Psychology and Behaviour*, vol. 22, pp. 249–260, Jan. 2014.
- [7] M. Miyatake and H. Ko, "Optimization of Train Speed Profile for Minimum Energy Consumption," *IEEE Transactions on Electrical and Electronic Engineering*, vol. 5, no. 3, pp. 263–269, May 2010.
- [8] Y. Yao, D. C. Lu, and D. Verstraete, "Power loss modelling of MOSFET inverter for low-power permanent magnet synchronous motor drive," in *2013 1st International Future Energy Electronics Conference (IFEEC)*, 2013, pp. 849–854.
- [9] S. Xue *et al.*, "Iron Loss Model for Electrical Machine Fed by Low Switching Frequency Inverter," *IEEE Transactions on Magnetics*, vol. 53, no. 11, pp. 1–4, Nov. 2017.
- [10] K. Stoyka, R. A. P. Ohashi, and N. Femia, "Behavioral Switching Loss Modeling of Inverter Modules," in *2018 15th International Conference on Synthesis, Modeling, Analysis and Simulation Methods and Applications to Circuit Design (SMACD)*, 2018.
- [11] K. Wei, C. Zhang, X. Gong, and T. Kang, "The IGBT Losses Analysis and Calculation of Inverter for Two-seat Electric Aircraft Application," *Energy Procedia*, vol. 105, pp. 2623–2628, May 2017.
- [12] A. Mahmoudi, W. L. Soong, G. Pellegrino, and E. Armando, "Loss Function Modeling of Efficiency Maps of Electrical Machines," *IEEE Transactions on Industry Applications*, vol. 53, no. 5, pp. 4221–4231, Sep. 2017.
- [13] M. Fan, J. Chai, and X. Sun, "Induction motor parameter identification based on T-model equivalent circuit," in *2014 17th International Conference on Electrical Machines and Systems (ICEMS)*, 2014, pp. 2535–2539.
- [14] A. Patel, H. Chandwani, V. Patel, and K. Patel, "Prediction of IGBT power losses and junction temperature in 160kW VVVF inverter drive," *Journal of Electrical Engineering*, vol. 12, no. 2, pp. 1–7, 2014.
- [15] X. Yang, X. Li, B. Ning, and T. Tang, "A Survey on Energy-Efficient Train Operation for Urban Rail Transit," *IEEE Transactions on Intelligent Transportation Systems*, vol. 17, no. 1, pp. 2–13, Jan. 2016.