

Simplified Map-based Selection of Optimal Spindle Speeds When Milling Complex Structures

Krzysztof J. Kalinski¹[\[0000-0003-1658-4605\]](#), Marek A. Galewski¹[\[0000-0003-3703-4012\]](#), Michal R. Mazur¹[\[0000-0003-1405-909X\]](#)

¹ Gdansk University of Technology, Faculty of Mechanical Engineering
G. Narutowicza 11/12, 80-233 Gdansk, Poland
margalew@pg.edu.pl

Abstract. In the paper a method for selecting optimal spindle speeds for complex structures during milling operations is presented. It is based on the selection of the spindle speed in accordance with a simple equation resulting from the minimisation of vibration energy, which leads to the minimisation of the work of cutting forces presented in previous elaborations by the authors [1]. Optimal spindle speeds are obtained for many points selected on machined surface thanks to the results of the modal test. The effectiveness of the proposed method is verified based on the results of experimental research. Reduction of vibration level, improvement of surface quality and reduction of milling time were obtained.

Keywords: Face milling, Vibration surveillance, Optimal spindle speed

1 Introduction

During milling operations, a significant dynamic phenomenon is the relative vibrations of the tool and workpiece. The negative effects of these vibrations are: reduced quality of the surface treated, increased tool wear, reduced overall machine tool performance, and in extreme cases even destruction of the tool or workpiece [2, 3]. The most important causes of the phenomenon of vibration generation during milling are kinematic excitation caused by repeated immersion of cutting edges in the workpiece, as well as internal feedback in the machine-holder-workpiece-tool system [2, 3]. Various methods of reducing and avoiding vibrations have already been developed [2, 4]. However, many of them were used only for research purposes, and for various reasons did not meet industrial applications. Some of these reasons are: the need to modify the internal machine tool or control system, the need for additional, expensive equipment (sensors, actuators), specialized knowledge needed to tune the parameters (for example to configure the vibration control algorithm), etc. Industrial practice requires fast, simple and low-cost methods that do not require complicated and expensive equipment or time-consuming additional operations (for example, building a computational model, tuning it and performing a large number of simulations). In order to increase efficiency while maintaining surface quality and minimizing vibrations, including avoiding vibrations,

one clear method for selecting the spindle speed is proposed, which is based on the experimental identification of the dynamic properties of the workpiece.

The method was developed based on previous work of authors [1, 5, 6, 7]. It belongs to a wider group of vibration reduction methods that use the spindle speed change [8, 9, 10] or adjust the spindle speed to selected properties of the machining process [11, 12]. One of the advantages of these methods is that they generally neither require modification of the machine tool's structure nor the use of complicated devices.

2 Description of the milling process

Let us consider the surface machining process of a large-size workpiece moving at feed speed v_f by the milling head (number of edges z) rotating at the spindle speed n (Fig. 1). The cutting depth is a_p . A dynamic analysis of the face milling process was carried out based on the following assumptions [13]:

- The spindle with the tool mounted in the holder and table with the workpiece are separated from the machine tool structure. Other parts of the milling machine are recognised as those whose impact can be neglected [1, 3, 14].
- The flexibility of the tool and the flexibility of the workpiece are taken into account. The latter applies in particular to the flexible large-size workpiece [15].
- Coupling elements (CEs) are applied for modelling the cutting process dynamics.
- An effect of first pass of the edge along cutting layer causes proportional feedback, and the effect of multiple passes causes delayed feedback additionally.

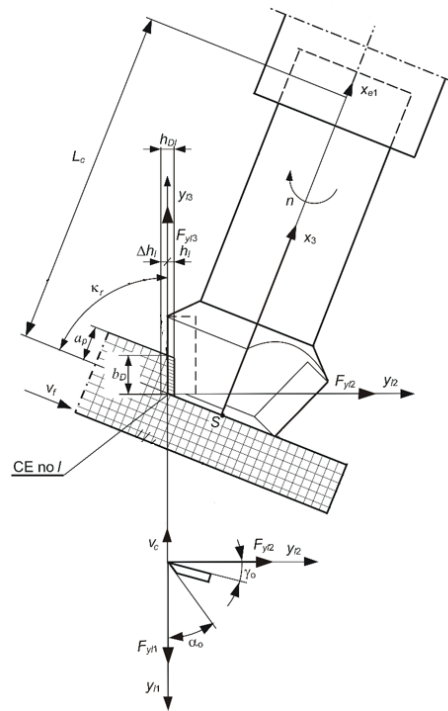

Fig. 1. Face milling scheme of a large-size workpiece

For the instantaneous point of contact between the selected tool edge and the workpiece (idealized by the CE no. l), a proportional model of the cutting dynamics was taken into account [13]. On the basis of this model, the cutting forces depend proportionally on the instantaneous thickness of the cutting layer $h_i(t)$, as well as on the instantaneous width of the cutting layer $b_i(t)$; both change in time. In accordance with the direction of

action, we isolate the component of the cutting force F_{yl1} acting along the nominal cutting velocity v_c , the component of the cutting force F_{yl2} acting along the thickness of the cutting layer, and the component of the cutting force F_{yl3} acting along the width of the cutting layer, i.e.:

$$F_{yl1}(t) = \begin{cases} k_{dl} b_l(t) h_l(t), & h_l(t) > 0 \wedge b_l(t) > 0, \\ 0, & h_l(t) \leq 0 \vee b_l(t) \leq 0, \end{cases} \quad (1)$$

$$F_{yl2}(t) = \begin{cases} \mu_{l2} k_{dl} b_l(t) h_l(t), & h_l(t) > 0 \wedge b_l(t) > 0, \\ 0, & h_l(t) \leq 0 \vee b_l(t) \leq 0, \end{cases} \quad (2)$$

$$F_{yl3}(t) = \begin{cases} \mu_{l3} k_{dl} b_l(t) h_l(t), & h_l(t) > 0 \wedge b_l(t) > 0, \\ 0, & h_l(t) \leq 0 \vee b_l(t) \leq 0, \end{cases} \quad (3)$$

where:

- $b_l(t) = b_D(t) - \Delta b_l(t)$,
- $h_l(t) = h_{Dl}(t) - \Delta h_l(t) + \Delta h_l(t - \tau_l)$,
- $b_D(t)$ – desired cutting layer width; $b_D(t) = a_p(t)/\cos \kappa_r$,
- $\Delta b_l(t)$ – dynamic change in cutting layer width for CE no. l ,
- $h_{Dl}(t)$ – desired cutting layer thickness for CE no. l ; $h_{Dl}(t) \cong f_z \cos \varphi_l(t)$,
- $\Delta h_l(\cdot)$ – dynamic change in cutting layer thickness for CE no. l ,
- k_{dl} – average dynamic specific cutting pressure for CE no. l ,
- μ_{l2}, μ_{l3} – cutting force ratios for CE no. l , as quotients of forces F_{yl2} and F_{yl1} , and forces F_{yl3} and F_{yl1} ,
- τ_l – time-delay between the same position of CE no. l and of CE no. $l-1$,
- κ_r – edge angle,
- f_z – feed per edge.

3 The method of selecting the optimal spindle speeds

3.1 Map of the optimal spindle speeds for the workpiece

In [1] a method for optimal choice of spindle speed based on the minimisation of vibration energy, leading to minimisation of the work of the cutting forces along the thickness of the cutting layer, is presented. This is expressed by the equation (4), which is similar to the expression based on the spindle speed adjustment to the optimal phase shift proposed by Liao and Young [11]:

$$\frac{zn_\alpha}{60} = \frac{f_\alpha}{0.25+k}, \quad (4)$$

where:

- f_α – dominant natural frequency [Hz],
- n_α – optimal spindle speed that corresponds to vibration at frequency f_α [rev/min],
- z – number of cutting edges.

The only unknown item in Eq. (4) is the dominant natural frequency f_α . It may be obtained, for example, by performing a modal test. However, it may not be possible to

determine the dominant frequency at all points of the surface by means of testing methods, so the MES model of the workpiece is prepared and tuned according to the results of the modal test. With this MES model, you can synthesise the frequency response functions (FRF) for each workpiece point in all its directions. However, the FEM model must be prepared and well correlated according to the results of the modal test before FRF synthesis. This step may seem time-consuming and requires knowledge about both FEM modelling and modal identification methods. After preparing the model and obtaining the FRF, you can start to map the optimal spindle speeds. The highest amplitude of the FRF indicates the dominant natural frequency. It is assumed that the excitation force from the milling tool does not influence the important natural frequencies of the workpiece. With dominating f_α frequencies, the optimal spindle speed for all selected points on the workpiece surface is calculated using (4). In this way, a map of the optimal spindle speeds is obtained. The use of the map requires modification of the Numerical Control (NC) code of the milling machine, which can be performed e.g. as a post-processing task for CAM software. The spindle speed is adjustable for each path of the milling tool. The feed speed is also adjusted to maintain a constant feed value per tooth.

In [5, 6, 7] the whole procedure for selection of the optimal spindle speeds for objects with complex shapes, including examples of experimental results, is proposed and is shown in Fig. 2. The main disadvantage of this method is the need to prepare the FEM model of the workpiece and then correlate it with the results of the modal test, which can be very time-consuming.

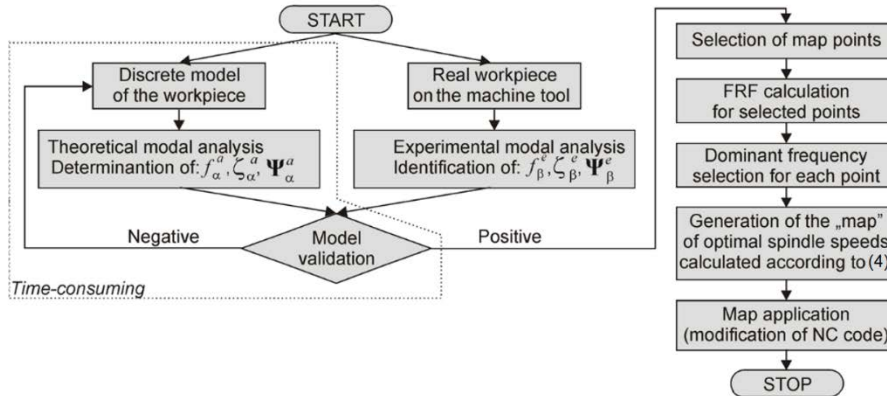

Fig. 2. An overall scheme of the method for creating a map of optimal spindle speeds, based on a discrete workpiece model; f - natural frequency, ζ - damping coefficient, Ψ - matrix of normal modes

3.2 A simplified approach for obtaining map of the optimal spindle speeds

In order to simplify and shorten the map creation process, it is proposed to use the results of the modal test (i.e. FRF calculated for selected points of the workpiece surface) directly to identify the dominant frequency. Optimal spindle speeds (based on

dominant natural frequencies and application (4) for each) are then used for milling. The calculated spindle speed applies to the surface of the workpiece around the modal test point. The more modal tests are available for different points, the more accurate the map is. The scheme of the proposed method is shown in Fig. 3.

The main advantage of the proposed method is the significant reduction of the time needed to obtain optimal spindle speeds compared to the method based on a discrete workpiece model. An extremely time-consuming part of the original (i.e. not simplified) method is the MES modelling and tuning, which can take many hours or even days in case of complex structures. In the case of a simplified approach, only modal tests are carried out and the dominant frequencies based on the FRF analysis are selected. A simple mode selection technique can be used, but modal identification methods such as ERA or p-LSCFD [16] can also be used to ensure the correct mode selection. It should also be noted that modal tests are limited only to machined surfaces. There is no need to perform them in other zones because the vibrations that occur there are not important from the viewpoint of the machining process. However, in a method based on a discrete model of the whole workpiece, such points would be needed to validate the FEM model. It should also be mentioned that during the modal tests performed for single points placed on the machined surface, the excitation is applied directly in the places where the machining will be performed, which should excite mainly the modes that will later be excited by the milling process. Modes that are not activated during machining do not interfere with the milling process and can therefore be neglected. In a simplified method, the choice of the spindle speed is directly based on modal identification results, which consists of all the elements influencing the dynamic properties of the workpiece.

In production practice, a lot of identical elements are often produced. In fact, each workpiece can vary slightly, and above all, each workpiece can be fixed to the table in a little bit different manner (for example, with different clamping forces). This leads to the non-uniformity of dynamic properties between the milled workpieces, even if they are theoretically identical. Even a small difference in the dominant frequency (several Hz) can cause a noticeable (several dozen or even hundreds of rev/min) change in the optimal spindle speed, especially in the case of tools with a small number of teeth.

Due to the relatively short time needed to select the speed using the simplified method, it is possible to create or at least adjust the map for each workpiece individually. In addition, if certain problems are identified during milling (in terms of increased

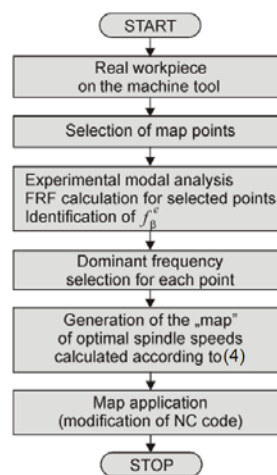

Fig. 3. An overall scheme of a simplified method for creating a map of optimal spindle speeds; f_{β}^e - natural frequency from experiments

vibration), it is very easy to improve the map by performing modal tests at these additional workpiece points. There is no need to recalculate the full workpiece model, as it would be needed in a method based on a discrete model of the whole workpiece.

4 Experimental results

4.1 The workpiece and standard milling parameters

The workpiece used during experimental research is presented in Fig. 4. It was a complex object made of STW22 03M steel, selected from a joint production program of an industrial company. The outer size of the workpiece was 2085x1116x548 mm. Modal tests were carried out and the vibration of the workpiece was measured during milling using the following hardware and software configuration [17]: 9 DJB A/120V IEPE accelerometers, measuring range ± 75 g; PCB 086C03 modal hammer, range ± 2224 N; IEPE conditioner; industrial National Instruments PXI-8106 Real Time controller with NI PXI 4496 DAQ card; laptop working under the LabView 2016 environment. Vibration sensors positions are shown in Fig. 4. Sensors - IEPE accelerometers - have been mounted on the inner surface of the part so that they do not interfere with the cutting process. Surface no. 1 was milled. Full face milling was performed first, with the tool moving from the left (starting near the accelerometer 22) to the right. Down milling was then carried out with the tool moving in the opposite direction (starting near the accelerometer 25). These two operations formed one complete pass for surface 1. The surface length was 1778 mm, width 57.5 mm. Milling was carried out using a Sandvik 4-edge milling head, $\phi 44$ mm

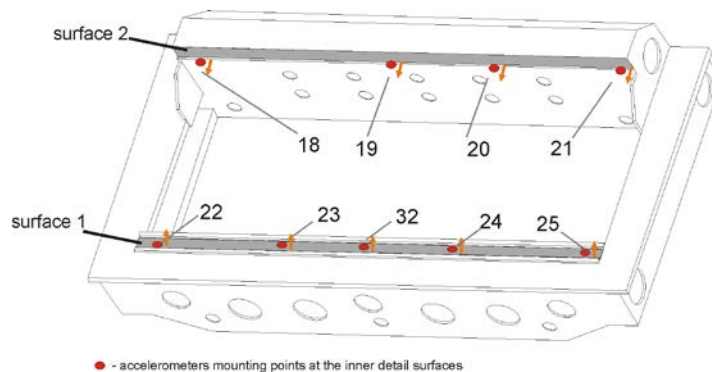

Fig. 4. Schematic of the workpiece with the numbers of accelerometers and marked fixing points

The standard parameters used in the milling process of a common production scheme of cooperating industry for the presented workpiece are: $n = 1300$ rev/min, $v_f = 600$ mm/min, $a_p = 1$ mm. The vibration level measured during milling with these parameters is treated as a reference for other methods. Vibrations during milling at standard parameters were generally very low, so its further reduction was difficult.

4.2 Modal identification and spindle speed selection

Experimental modal tests of the workpiece were carried out for each fastening point of the accelerometer placed on the machined surface (see Fig. 4) using modal hammer. For each point, the FRF was determined and the gain from “force-acceleration” to “force-displacement” was calculated. Then, the dominant frequencies were selected directly from the FRF plots. Only frequencies above 75 Hz were considered during the selection because the FRF coherence values for frequencies below 75 Hz were low and the modal test results were questionable. FRF for points on surface 1 is shown in Fig. 5. In the figure, only the FRF is shown for a case where a modal test with close proximity excitation was performed, i.e. for example, FRF for sensor A22 was calculated for a modal test performed with excitation applied near the position of the sensor. When selecting the dominant frequency, all other FRFs (not shown here) were also taken in account. The dominant frequencies and the corresponding optimal spindle speeds are selected in Table 1.

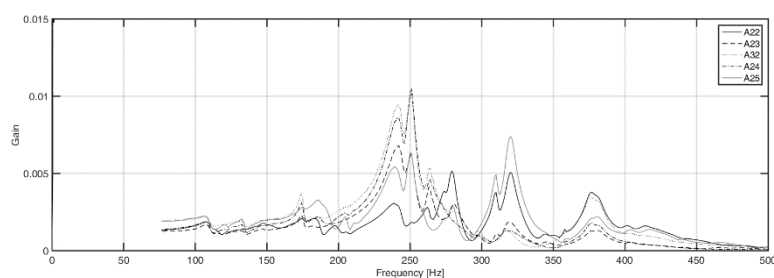

Fig. 5. FRF for selected points of the surface 1

Table 1. Selection of the optimal spindle speed according to the map

Surface 1				
Sensor zone	Dominant frequency [Hz]	k	z	Optimal spindle speed n [rev/min]
A22	279	2	4	1860
A23	242	2	4	1613
A32	251	2	4	1673
A24	251	2	4	1673
A25	320	2	4	2134

4.3 MILLING RESULTS

Milling operations were carried out for both surfaces of the workpiece and various spindle speeds selected in accordance with the standard parameters. Table 2 shows the selected spindle speeds and feed speeds. In tables 2 and 3, Axx is the number of accelerometer according to Fig. 4. Table 3 of RMS (Root Mean Square) presents displacement values for the milling operations carried out observed at the measuring points during the passing of the tool over the given sensor. For example, the value for sensor

A22 has been calculated for a period of time from the beginning of the milling operation (excluding the time period when the tool entered the material) to the point where the tool was located midway between the sensor positions A22 and A23 (see Fig. 6 for illustrative example and Fig. 3 for sensor positions). The displacement values were calculated based on the double integration of the measured accelerations. Relative values of RMS change are also presented to help noticing vibration level change. Vibration reduction is marked with the "-" sign. Table 4 shows surface roughness values (Ra and Rz). The reference values were measured at 4 points along the surface points, but later, after subsequent milling operations, they were measured at 5 points (in sensor positions).

Milling with standard parameters was done first, and its results are treated as a reference for the following tests. According to the results, the average reduction in vibrations compared to standard parameters was over 60%. The surface quality has also been improved.

Table 2. Selected spindle speeds and feed speeds

Spindle speed	a_p [mm]	Spindle speed n [rev/min] (Feed speed v_f [mm/min])				
		A22	A23	A32	A24	A25
Std.	1	1300 (600)				
Map	1	1860 (858)	1613 (745)	1673 (772)	1673 (772)	2133 (985)

Table 3. RMS values of displacements for measurement points on milled surface and relative RMS change (reference to milling at standard parameters)

Milling type	Spindle speed	Displacements RMS [mm]					
		A22	A23	A32	A24	A25	Average
Full	Std.	1.85e-4	6.04e-4	8.64e-4	7.22e-4	2.95e-4	5.94e-4
Down	Std.	5.51e-4	21.48e-4	28.22e-4	22.02e-4	5.21e-4	19.31e-4
Full	Map	1.33e-4 -28,1%	2.05e-4 -66,1%	2.93e-4 -66,1%	2.57e-4 -64,4%	2.32e-4 -21,4%	2.22e-4 -62,6%
Down	Map	3.81e-4 -30,9%	7.15e-4 -66,7%	9.31e-4 -67,0%	7.86e-4 -64,3%	5.57e-4 6,9%	7.03e-4 -63,6%

Table 4. Surface roughness for selected points

Spindle speed	Ra					Rz				
	Std.	1.623	1.624	1.657	1.093	8.220	7.860	8.490	6.940	
Map	0.863	1.068	0.975	0.987	0.879	4.72	7.82	6.14	6.94	4.02



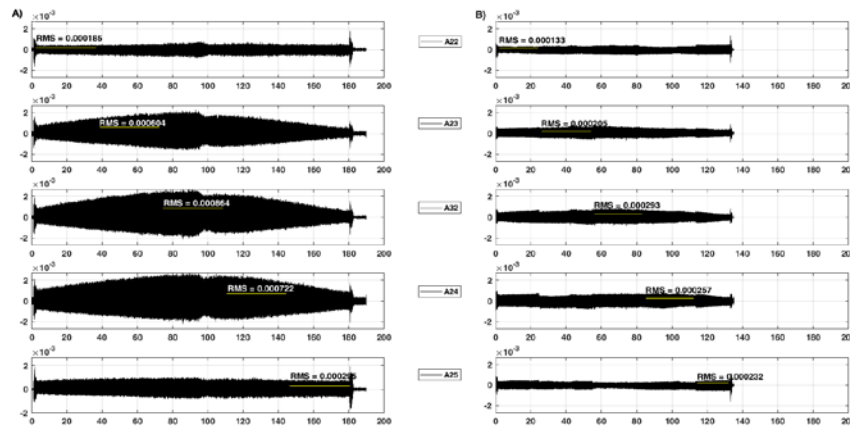

Fig. 6. Vibration of the workpiece during full milling with A) standard parameters and B) parameters according to the map of the optimal spindle speeds

5 Conclusions

The effectiveness of the proposed method for selecting the optimal spindle speed has been proven while milling large-size structures. The vibration level was reduced by 60% compared to the vibration level observed during milling at standard parameters. The overall process duration was reduced, which was the result of choosing higher than standard feed speeds. The surface quality has also been improved.

The optimum spindle speeds for each workpiece milling zone have been achieved in short time due to the elimination of some time-consuming components of the procedure. The latter applies, for example, to the lack of the need to create a FEM model and adapt it to the results of identifying modal parameters.

The proposed method is intended as a quick tool for selecting the spindle speed, especially when only part of the workpiece is machined or the standard parameters must be locally tuned, for example in case of vibrations occurring locally. Along with the increase in the number of map points, modal tests last longer. In case when the entire workpiece or almost all of its surfaces are machined, the method of selecting the optimal spindle speed based on the discrete model of the entire workpiece can be beneficial, since the time differences between the two methods will be relatively smaller.

Acknowledgements

The research was carried out as a part of tasks financed by the Polish National Centre for Research and Development, project TANGO1/266350/NCBR/2015, on “Application of selected mechatronic solutions for supervising the machining of large-size workpieces on multi-axis machining centres”.

Experimental investigations on the MIKROMAT 20V portal machining centre were made thanks to cooperation with PHS HYDROTOR S.A. in Tuchola, Poland.

References

1. Kaliński K. J., Galewski M. A.: Optimal Spindle Speed Determination for Vibration Reduction During Ball-End Milling of Flexible Details. *International Journal of Machine Tools and Manufacture* 92, 19-30 (2015).
2. Quintana G., Ciurana J.: Chatter in machining processes: a review. *International Journal of Machine Tools and Manufacture* 51, 363-376 (2011).
3. Tomkow J.: *Vibro stability of machine tools; The Scientific and Technical Publication: Warsaw, Poland (1997) (in Polish)*.
4. Munoa J., Beudaert X., Dombovari Z., Altintas Y., Budak E., Brecher C., Stepan G.: Chatter suppression techniques in metal cutting. *CIRP Annals - Manufacturing Technology* 65, 785–808 (2016).
5. Kalinski K. J., Mazur M. R., Galewski M. A.: High speed milling vibration surveillance with the use of the map of optimal spindle speeds, *Proceedings of the 8th International Conference on High Speed Machining, ENIM, Metz, 300-305 (2010)*.
6. Kalinski K. J., Mazur M. R., Galewski M. A.: Optimal Spindle Speed Map for Chatter Vibration Reduction During Milling of Bow Thruster Blade. *Solid State Phenomena*. 198, 686-691 (2013).
7. Kalinski K. J., Galewski M. A., Mazur M. R.: High Speed Milling vibration surveillance with optimal spindle speed based on optimal speeds map. *Key Engineering Materials*. 597, 125-130 (2014).
8. Kalinski K. J., Galewski M. A.: Chatter vibration surveillance by the optimal-linear spindle speed control. *Mechanical Systems and Signal Processing*. 25(1), 383-399 (2011).
9. Soliman E., Ismail F.: Chatter suppression by adaptive speed modulation. *International Journal of Machine Tools and Manufacture*. 37 (3), 355–369 (1997).
10. Jemielniak K., Widota A.: Suppression of self-excited vibration by the spindle speed variation method. *International Journal of Machine Tool Design and Research*. 24, 207-214 (1984).
11. Liao Y. S., Young Y. C.: A new on-line spindle speed regulation strategy for chatter control. *International Journal of Machine Tools & Manufacture* 35(6), 651-660 (1996).
12. Tarn Y. S., Lee E. C.: A Critical Investigation of the Phase Shift Between the Inner and Outer Modulation for the Control of Machine Tool Chatter, *International Journal of Machine Tools and Manufacture*. 37, 1661–1672 (1997).
13. Kalinski K. J.: The finite element method application to linear closed loop steady system vibration analysis. *International Journal of Mechanical Sciences*. 39, 315-330 (1997).
14. Uriarte L., Zatarain M., Axinte D., et al.: Machine tools for large parts. *CIRP Annals-Manufacturing Technology*. 62(2), 731–750 (2013).
15. Sarhan A. D., Besharaty S. R., Akbaria J., Hamdi M.: Improvement on a CNC Gantry Machine Structure Design for Higher Machining Speed Capability. *World Academy of Science, Engineering and Technology. International Journal of Mechanical, Aerospace, Industrial, Mechatronic and Manufacturing Engineering*. 9, 534–538 (2015).
16. Heylen W., Lammens S., Sas P.: *Modal analysis theory and testing. KU Leuven; (2007)*.
17. Galewski M.A.: Application of the LabView Environment for Experimental Modal Analysis Support. In: *From Finite Elements Method to Mechatronics*, Eds. K. J. Kaliński, K. Lipiński, The Publication of Gdansk University of Technology, Gdansk, 105-118 (2017) (in Polish).