

Thermal and technological aspects of double face grinding of Al₂O₃ ceramic materials

AUTHORS

Mariusz Deja^{1*}, Michael List², Linus D. Lichtschlag², Eckart Uhlmann²

AFFILIATION

¹Faculty of Mechanical Engineering, Department of Manufacturing and Production Engineering, Gdansk

University of Technology, Gabriela Narutowicza Street 11/12, 80 - 233 Gdańsk, Poland

²Chair of Machine Tools and Manufacturing Technology, Institute for Machine Tools and Factory Management,

Technische Universität Berlin, Pascalstraße 8 - 9, 10587 Berlin, Germany

*Corresponding Author, Phone: +48 58 347 29 67, Mail: mariusz.deja@pg.edu.pl

ABSTRACT

Double face grinding with planetary kinematics is a process to manufacture workpieces with plan parallel functional surfaces, such as bearing rings or sealing shims. In order to increase the economic efficiency of this process, it has to be advanced permanently. The temperature in the contact zone of most grinding processes has a huge influence on the process efficiency and the workpiece qualities. In contrast to most grinding processes these influences are unknown in double face grinding with planetary kinematics. The application of standard measuring equipment is only possible with high effort due to the inaccessibility of the working space during the machining process. Furthermore, measurement of the workpieces temperature in the considered machining system is not reported. Due to that fact, the intensive cooling has so far been the only method to avoid the occurrence of thermal defects especially in case of brittle ceramic materials. The influence of the mean cutting speed, the tools' cutting performance and the coolant flow on the temperature change of the workpieces made of Al₂O₃ ceramic materials was investigated with the use of a newly developed method. The first empirical approach to predict the change in temperature of the ceramic workpieces while processing is proposed. The developed measuring method can be used for obtaining experimental temperature data in other processes, such as polishing and lapping for which only theoretical models exist.

KEYWORDS

Double face grinding with planetary kinematics; abrasive machining; workpiece temperature; ceramic material; empirical model; process efficiency

HIGHLIGHTS

- Development of a method for measuring workpiece temperature in double face grinding with planetary kinematics
- In-process temperature data acquisition
- Determination of an empirical model to predict the temperature of a ceramic workpiece during processing time
- Investigation of the influence of the tools' cutting performance and coolant flow on the temperature change

1. INTRODUCTION

Workpieces with plan parallel functional surfaces are used in a wide range of industrial applications. Lapping is one of the main processing steps of hard and brittle materials. The lapping process aims to remove the surface irregularities caused by the preceding processing step by wire-sawing of sapphires [1] or silicon wafers [2, 3]. To machine workpieces such as sapphire wafers or ceramic sealing shims, double face grinding with planetary kinematics can be used instead of lapping. Substitution of the lapping process by double face grinding enables significant reduction of process time and production costs per a work part [4]. In double face grinding workpieces are placed in externally teathed workpiece holders. These workpiece holders are located between two grinding wheels and are driven by a fixed outer and movable inner pin ring, [Figure 1](#). The rotational movement of both grinding wheels and the inner pin ring leads to a relative motion of the workpieces and the grinding wheels, comparable to planetary gearboxes. In comparison to other grinding processes such as peripheral longitudinal surface grinding, double face grinding with planetary kinematics offers many advantages. These include the tension free mounting of the workpieces as well as the equally distributed load on the entire surface of the workpieces [5-7].

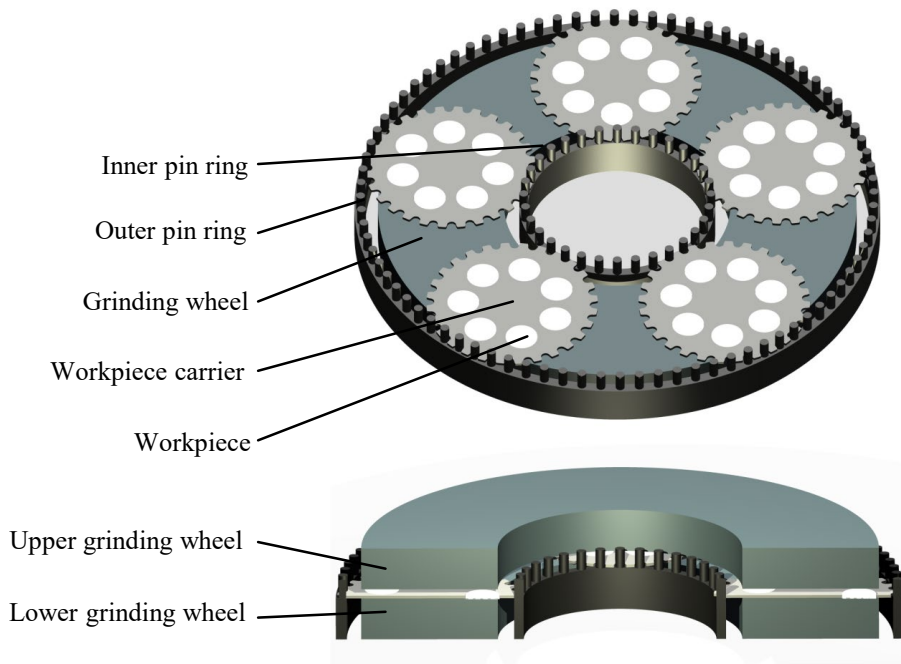

Figure 1: Main components of the machine system for double face grinding with planetary kinematics [8]

First approaches to increase the process efficiency of double face grinding processes with planetary kinematics were made by UHLMANN ET AL. [9, 10]. They examined influence of the mean cutting speed \bar{v}_c , the grain size d_g as well as the grain concentration C on the height reduction rate $\Delta\dot{h}_w$ and the profile wear Δh_{ps} of the grinding tool. Based on these two parameters, UHLMANN ET AL. [9, 10] introduced the process efficiency value E_{va} , which allows estimating the process efficiency of double face grinding processes with planetary kinematics [8, 9, 11]. Furthermore, a model to determine the wear profile of the grinding tool was developed. Building on this model an algorithm to design grinding tools was developed, minimising the profile wear Δh_{ps} for given application conditions [8, 10-14]. Beside the increase of the height reduction rate $\Delta\dot{h}_w$ and the reduction of the profile wear Δh_{ps} , the temperature T in the grinding process is a significant parameter determining the process efficiency. Therefore, to enable in-process data acquisition of the temperature while processing, it is necessary to implement a measurement system.

There are many factors which affect grinding temperature due to the complex relationships between process parameters and processing results [15]. The grinding performance, which is the product of the tangential force and the cutting speed, can be used to determine the grinding energy required for the chip formation [16]. The majority of mechanical energy input is transformed into heat in the grinding

zone. Heat is dissipated into the workpieces, chips, grinding wheels, coolant, which are used for surface formation and generation of residual stresses [16, 17]. Modelling and simulation of grinding can be used for process optimisation to obtain high precision parts and to avoid thermal damage in the workpiece. Capabilities and limitations of physical, empirical and heuristic process models used to calculate grinding force and temperature as well as to predict processing results including surface topography and surface integrity are presented in detail in BRINKSMEIER ET AL. [15] and MALKIN ET AL. [16]. Experimental results are crucial for the validation of existing theories and for the development of integrated grinding process models having more precise prediction ability on grinding forces and grinding temperatures [18, 19]. Due to measurement difficulties, calculations are required to be supported by indirect observations, e. g. detection of scratches and analysis of the depths of residual stress on machined surfaces.

Temperature measurements conducted using thermocouples or radiation sensors can be easily adapted for most grinding methods including cylindrical and flat conventional grinding [20-22]. The application of standard measuring equipment in lapping or double face grinding with planetary kinematics is practically infeasible due to inaccessibility of the working space during the machining process. Additionally, components are rotating and changing their position on the grinding wheel while processing. Workpiece temperature measurements in the considered machining system are not reported in the literature. Nonetheless, a deeper analysis of thermal effects in grinding with planetary kinematics is needed due to higher achievable cutting speeds compared with lapping processes. High temperatures can cause various types of thermal damage to the workpiece, such as burning and metallurgical phase transformations. Thermal analyses of grinding processes are usually based upon the application of moving heat source theory as discussed in MALKIN ET AL. [16]. The identification of heat distribution to different heat absorbers in the grinding zone is essential for accurate temperature prediction in grinding [23]. The heat distribution into the workpiece is often determined by matching measured and theoretical temperatures for given grinding conditions [24].

In this paper, a method for measuring the workpiece temperature in double face grinding with planetary kinematics is presented. Experimental results were used to determine the empirical model predicting the temperature of the ceramic workpiece while processing under given technological

parameters. The influence of the mean cutting speed, the tools' cutting performance and the coolant flow on the workpiece temperature change were investigated. The proposed method and obtained results will allow validating the numerical thermal model of the analysed process. The method is applicable to other abrasive processes such as polishing and lapping, for which only theoretical models of temperatures exist, due to measurement difficulties and limited accessibility to the working zone [25, 26].

2. EXPERIMENTAL SETUP AND INVESTIGATIONS

A prototypical machine tool for high speed and high performance double face grinding with planetary kinematics was developed at the Institute for Machine Tools and Factory Management (IWF), Technische Universität Berlin, Germany in cooperation with the machine tool manufacturer Stähli AG, Pieterlen/Biel, Switzerland. Based on intensive research activities in the field of processing brittle hard materials, it was shown that optimal cutting conditions are often connected to increased cutting speeds and grinding pressures. The result of an increased cutting speed is a higher height reduction rate Δh_w and a simultaneous considerable decrease of machining time [27, 28]. The machine tool system, which was used for the experimental analysis of the radius dependent velocity distribution, the effect of increased grinding wheel speeds and the wear pattern of the grinding wheel, is characterised by a highly rigid portal design. This makes it possible to realise high speeds as well as high forces and torques. Grinding wheel rotational speeds up to 2000 rpm and clamping forces up to 4000 daN are possible, which is a fourfold increase compared to conventional machines. In combination with a maximal rotational speed of the inner pin ring of 1000 rpm, mean cutting speeds \bar{v}_c of up to 45 m/s can be achieved.

A series of experiments was performed on Al_2O_3 workpieces to analyse the effect on temperature in the grinding zone using full-featured digital temperature loggers. The loggers saved the temperature data of the workpieces while grinding. Temperature loggers of type DS1922L [29] made by iButtonLink, Whitewater, USA, with an operating temperature range from $-40\text{ }^\circ\text{C}$ to $+85\text{ }^\circ\text{C}$, a resolution of $0.0625\text{ }^\circ\text{K}$, a temperature accuracy of $\pm 0.5\text{ }^\circ\text{K}$ and a minimum sample rate of 1 Hz were used to measure the temperature of the ceramic workpieces, [Figure 2](#).

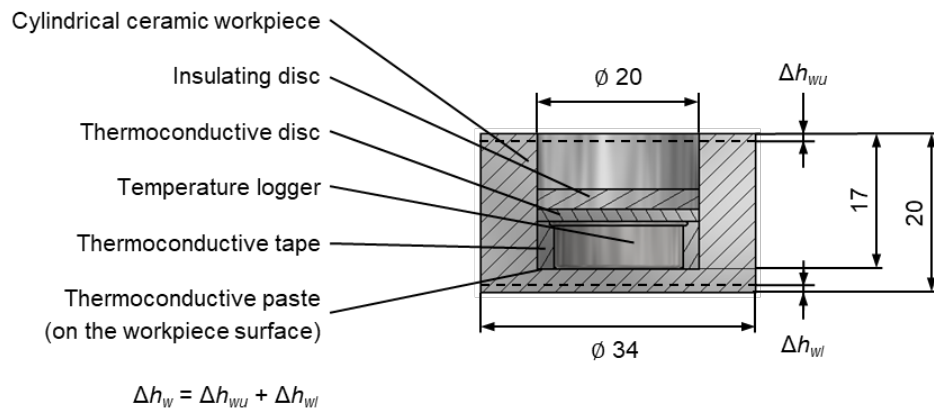

Figure 2: Measurement setup of a temperature logger in a workpiece

The standard uncertainty of the measurements after the calibration of selected temperature loggers is 0.13 °K. The logger was integrated in a workpiece. The generated heat was transmitted to the logger through the workpiece using thermoconductive elements. The coolant insulating disc was placed on the thermoconductive disc. One measuring device with a programmed and installed temperature logger as well as four cylindrical workpieces were placed in a single workpiece holder to measure the workpiece temperature while grinding, [Figure 3](#). Therefore, five loggers were placed in the five workpiece holders during each grinding process.

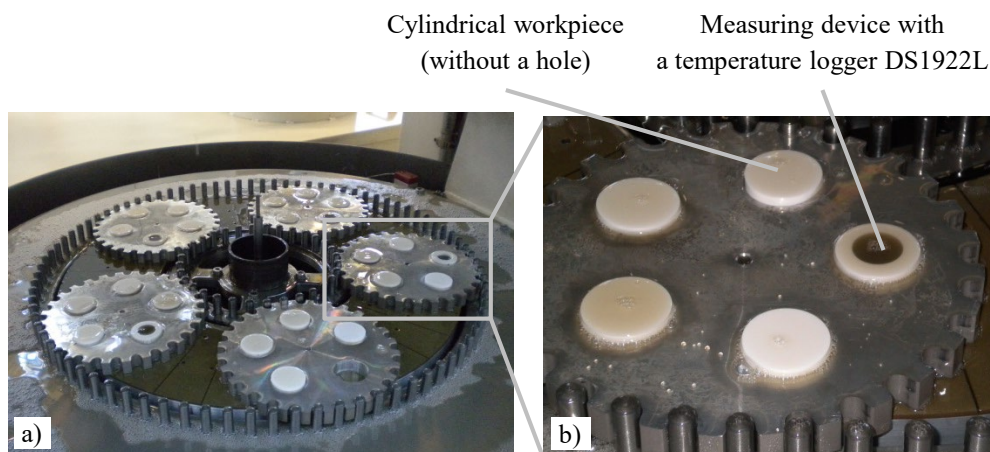

Figure 3: Arrangement of ceramic workpieces in a machining system for double face grinding with planetary kinematics: a) general view, b) single workpiece holder with a measuring device and four cylindrical workpieces

The main aim of the experiments was to examine the influence of the mean cutting speed \bar{v}_c on the temperature of ceramic workpieces. Since the height reduction rate $\Delta \dot{h}_w$ decreases while grinding due to tool wear a conditioning process was carried out periodically to restore the cutting performance of the grinding tool [30]. The grinding parameters of the performed experiments are presented in [Table 1](#).

Additionally, the influence of coolant flow on the workpiece temperature was examined only for the highest mean cutting speed $\bar{v}_c = 25$ m/s. Other parameters were not varied during the experiments.

Table 1: Grinding conditions during experiments

Grinding wheels		
Outer tool diameter r_o	mm	530
Inner tool diameter r_i	mm	265
Grain material		Diamond
Grain size d_g	μm	107
Abrasive grain concentration		C75
Bond type		Synthetic resin
Grinding parameters		
Mean cutting speed \bar{v}_c	m/s	10
		15
		25
Grinding pressure p	N/mm^2	0.11
Tool allocation B	%	11.53
Maximum depth of material removed per batch Δh_w		4.8
Coolant flow rate \dot{Q}_{lub}	l/min	40 ($\bar{v}_c = 10$ m/s; 15 m/s; 25 m/s) 20 ($\bar{v}_c = 25$ m/s)
Workpiece properties		
Material		Al_2O_3
Vickers hardness HV10	MPa	1100
Diameter d_w	mm	34
Initial height h_{w0}	mm	20

The workpiece dimensions allowed for a removal of $\Delta h_w = 4.8$ mm evenly distributed to the top and bottom of the workpiece, Figure 2. The height of the final sample was 15.2 mm and the value of the final distance between sensor and the workpiece bottom outer face was 0.6 mm. Figure 4 contains the development of the grinding process to obtain the temperature data for $\bar{v}_c = 15$ m/s and $\dot{Q}_{lub} = 40$ l/min.

Process
 Double face grinding with planetary
 Kinematics

Machine tool
 Stähli DLM 505 HS

Workpiece
 Type Test workpiece,
 cylindrical
 Material Al_2O_3
 Radius $r = 17.5$ mm

Temperature
 stabilization ①

Inspection of a
 measuring sampe ②

Removing loggers
 from workpieces ③

Process parameter

Allocation $B = 11.53$ %
 Cutting speed $\bar{v}_c = 15$ m/s
 Coolant lubricant Rhenus GP5
 Volume flow $\dot{Q}_{lub} = 40$ l/min
 Temperature $T_{lub} = 21.7$ °C

Tool

Type Winter D107C75
 Grain material Diamond
 Bonding type Synthetic resin
 Grain size $d_g = 107$ μ m
 Grain concentration $C = 3.3$ ct/cm³
 Outer radius $r_a = 265$ mm
 Inner radius $r_i = 132.5$ mm

— Logger 1
 — Logger 2
 — Logger 3
 — Logger 4
 — Logger 5

t_{bi} time at the beginning of experiment E_i

t_{ei} time at the end of experiment E_i

t_{maxi} time when maximum temperature in experiment E_i was reached

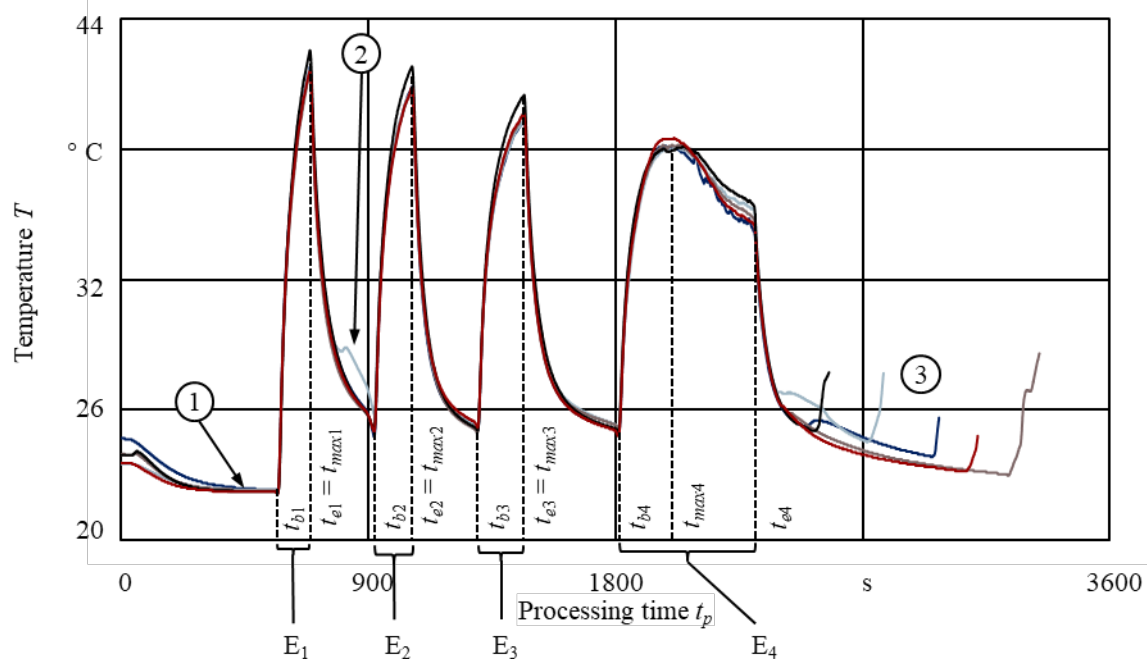

Figure 4: Workpiece temperatures recorded by loggers during four grinding experiments on Al_2O_3

During the experiments E_1 , E_2 and E_3 a height of 1 mm and during the last experiment E_4 a height of 1.8 mm was removed. Decreases of the height reduction rate Δh_w caused by the tool wear extended the processing time while the mean cutting speed \bar{v}_c remained constant. During the consecutive experiments E_1 , E_2 and E_3 the processing time t_p necessary for removing the same amount of material increased and resulted in a lower temperature. Intensive cooling and reduced cutting performance of

the tools caused a decreasing workpiece temperature after reaching the maximum value in experiment E₄, Figure 4.

The temperature was recorded once every second and the mean values of the workpiece temperatures during the entire processing time were used for modelling the temperature increase. In the analysed example with $\bar{v}_c = 15$ m/s, the maximum temperature was reached at the end of the machining operation in the experiments E₁, E₂ and E₃ ($t_{ei} = t_{maxi}$, for $i = 1, 2, 3$), Figure 5.

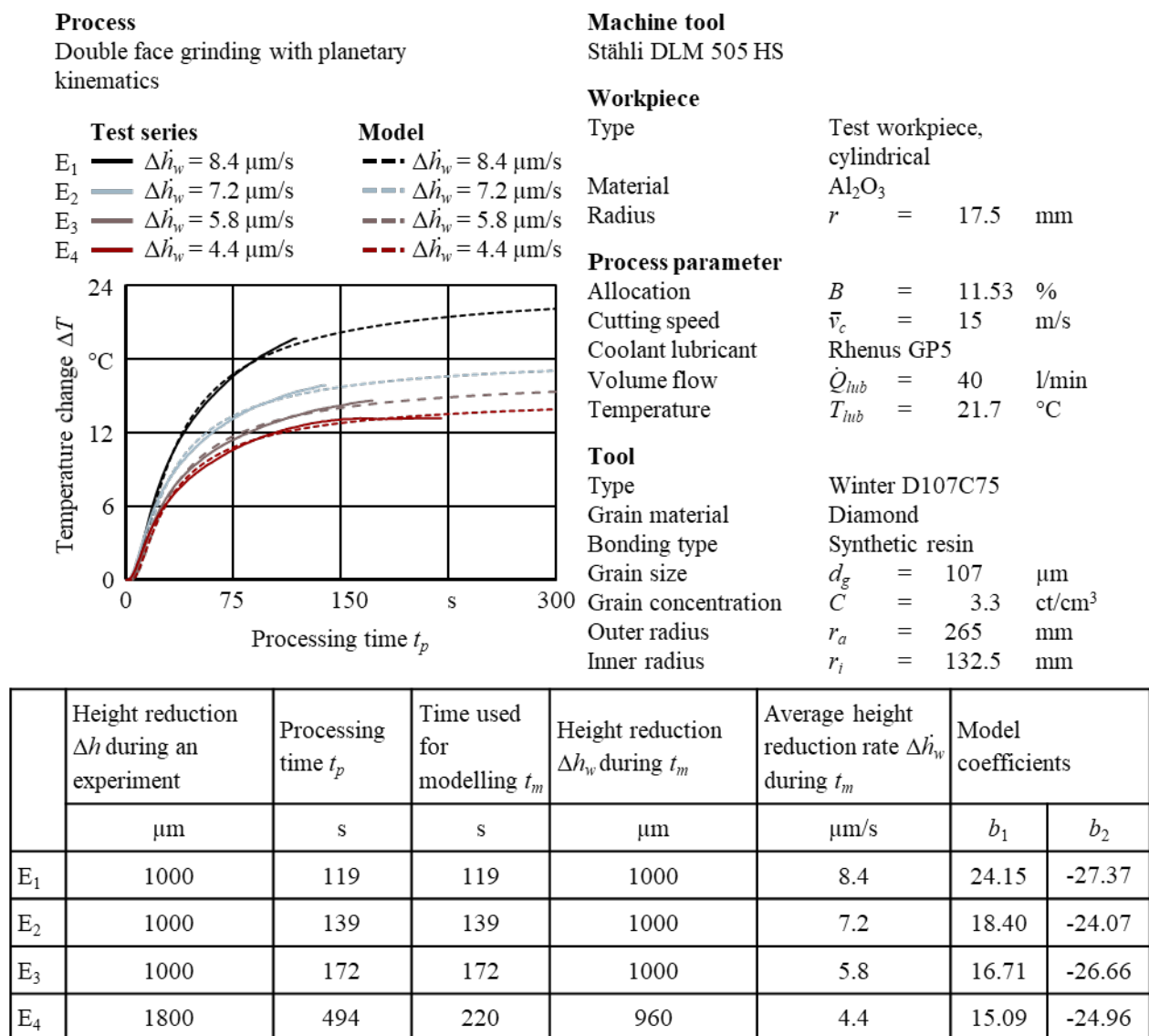

Figure 5: Experimental and theoretical temperature changes, process parameters and model coefficients

3. ANALYSIS OF EXPERIMENTAL RESULTS

The workpiece temperature changes show a progressively increasing behaviour towards a maximum value as seen in Figure 5. Therefore, the dependency between the change in the temperature and the processing time was approximated taking the shapes of the experimentally determined curves into account, according to [31], and [Equation 1](#):

$$\Delta T = b_1 \cdot \exp(b_2/t_p) \quad (1)$$

ΔT is the change in temperature in °C, t_p is the time in s and b_1 as well as b_2 are model coefficients. Coefficient b_1 is a horizontal asymptote in the proposed nonlinear regression model of temperature changes. This coefficient can be assumed as the theoretical maximum temperature increase that could occur during the experiments under given technological parameters. The software package Matlab by MATHWORKS, Natick, Massachusetts, USA, was used to process the data, build an exponential model and do the curve fitting. The evaluated values of coefficients for the experiments at $\bar{v}_c = 15$ m/s are provided in Figure 5. One of the advantages of the proposed model is that the theoretical maximum temperature increase is directly given as coefficient b_1 . Accurate curve fitting enables practical utilisation of the model for industrial applications usually carried out with smaller material allowances that require short processing times compared to the performed experiments. In case of the longer processing time, the temperature should not exceed the theoretical maximum value due to a typical decrease in the cutting performance of the grinding tools. Lower cutting performance reduces height reduction rate $\Delta \dot{h}_w$ which leads to lower workpiece temperatures. This can be seen in experiment E₄ with $\Delta \dot{h}_w = 4.4$ µm/s, Figure 4 and Figure 5.

During subsequent experiments E₅ and E₆, higher removal rates $\Delta \dot{h}_w$ resulted in the shorter processing time t_p and in larger temperature changes using $\bar{v}_c = 25$ m/s, [Figure 6](#). The experimental data from experiments E₅ and E₆ show that coolant flow has an essential influence on the workpiece temperature. Experiment E₅ was run with a slightly higher height reduction rate $\Delta \dot{h}_w = 18.6$ µm/s at half of the flow rate $\dot{Q}_{lub} = 20$ l/min of E₆ which was run with $\Delta \dot{h}_w = 17.6$ µm/s and $\dot{Q}_{lub} = 40$ l/min. Reducing the

coolant flow rate by half caused a noticeable temperature increase, Figure 6. For the experiments E₅ and E₆, the process and model parameters are depicted also in Figure 6. The coefficient b_1 for experiment E₅ is approximately twice as high as coefficient b_1 for experiment E₆.

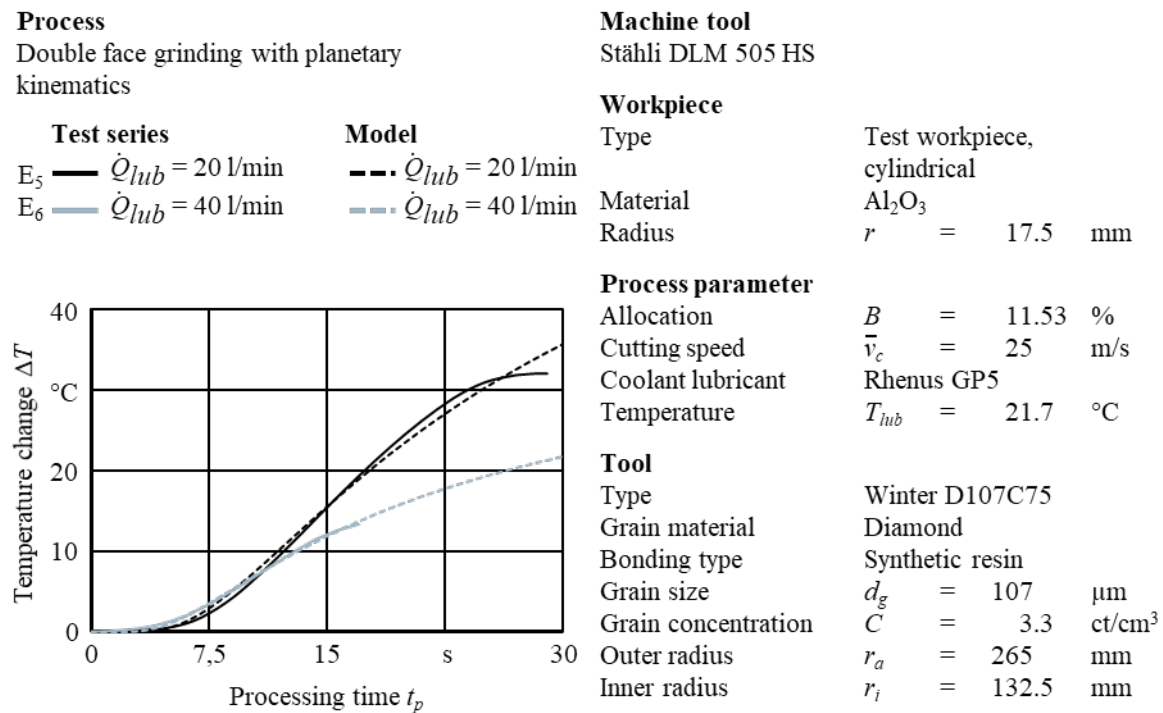

	Height reduction Δh during an experiment	Processing time t_p	Time used for modelling t_m	Height reduction Δh_w during t_m	Average height reduction rate $\Delta \dot{h}_w$ during t_m	Model coefficients	
	μm			μm		μm/s	b_1
E ₅	540	29	29	540	18.6	81.91	-24.96
E ₆	300	17	17	300	17.6	39.68	-18.12

Figure 6: Experimental and theoretical temperature changes, process parameters and model coefficients with varying lubricant flow rates

The height reduction rates $\Delta \dot{h}_w$ achieved during experiments E₇, E₈ and E₉ with a mean cutting speed of $\bar{v}_c = 10$ m/s are depicted in Figure 7. They are similar to the height reduction rates $\Delta \dot{h}_w$ from previous experiments E₂, E₃ and E₄ with a mean cutting speed of $\bar{v}_c = 15$ m/s, Figure 5. Due to the lower cutting speed \bar{v}_c , the temperatures measured during experiments E₇, E₈ and E₉ depicted in Figure 7 are lower than in the corresponding experiments E₂, E₃ and E₄ depicted in Figure 5. That is also reflected by the lower values of model parameters.



Process
Double face grinding with planetary kinematics

Machine tool
Stähli DLM 505 HS

Test series	Model
E ₇ — $\Delta\dot{h}_w = 7.2 \mu\text{m/s}$	— $\Delta\dot{h}_w = 7.2 \mu\text{m/s}$
E ₈ — $\Delta\dot{h}_w = 6.0 \mu\text{m/s}$	— $\Delta\dot{h}_w = 6.0 \mu\text{m/s}$
E ₉ — $\Delta\dot{h}_w = 4.8 \mu\text{m/s}$	— $\Delta\dot{h}_w = 4.8 \mu\text{m/s}$

Workpiece
Type Test workpiece, cylindrical
Material Al₂O₃
Radius $r = 17.5 \text{ mm}$

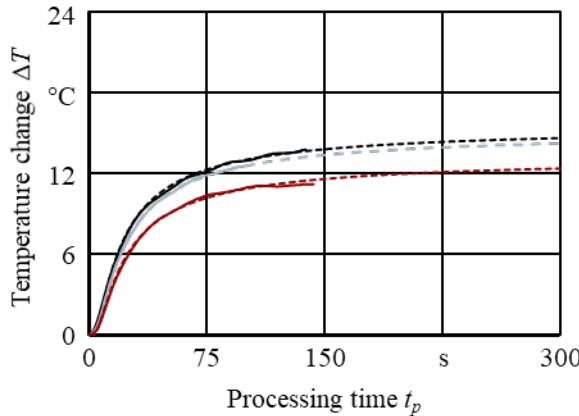

Process parameter
Allocation $B = 11.53 \%$
Cutting speed $\bar{v}_c = 10 \text{ m/s}$
Coolant lubricant Rhenus GP5
Volume flow $\dot{Q}_{lub} = 40 \text{ l/min}$
Temperature $T_{lub} = 21.7 \text{ }^\circ\text{C}$

Tool
Type Winter D107C75
Grain material Diamond
Bonding type Synthetic resin
Grain size $d_g = 107 \mu\text{m}$
Grain concentration $C = 3.3 \text{ ct/cm}^3$
Outer radius $r_a = 265 \text{ mm}$
Inner radius $r_i = 132.5 \text{ mm}$

	Height of material removed Δh during an experiment	Processing time t_p	Time used for modelling t_m	Height of material removed Δh_w during t_m	Average material removal rate $\Delta\dot{h}_w$ during t_m	Model coefficients	
	μm			μm	$\mu\text{m/s}$	b_1	b_2
E ₇	1000	138	138	1000	7.2	15.47	-17.49
E ₈	1000	176	100	600	6.0	15.16	-18.66
E ₉	1800	498	143	680	4.8	13.17	-19.47

Figure 7: Experimental and theoretical temperature changes, process parameters and model coefficients with lubricant flow rate $\dot{Q}_{lub} = 40 \text{ l/min}$

The time period used for modelling was shorter than the processing time for both experiments E₈ and E₉ because temperature decreased after reaching the maximum value at t_m . Similarly to experiment E₄ in Figure 4 and Figure 5, this was due to extensive cooling and low cutting performance of the grinding tools at the end of the last experiment, before the conditioning process.

CONCLUSIONS

Double face grinding with planetary kinematics offers many advantages in comparison to other grinding processes for finishing flat workpieces. These include the tension free mounting of the workpieces as well as equally distributed load on the entire surface of the workpieces. Nonetheless, the

investigation of double face grinding with planetary kinematics is still important due to the combination of grinding and lapping characteristics. Substitution of the lapping process by double face grinding enables significant reduction of the processing time and production costs per a work part. Thermal analysis of this process is required because the achievable cutting speeds in grinding are much higher than in lapping. Generation of high temperatures can cause various types of thermal damage on the workpiece, such as microcracks, burnings and metallurgical phase transformations. The influence of the mean cutting speed, the tools' cutting performance and the coolant flow on the temperature change of the ceramic workpieces were investigated. The main contribution and benefits of this work can be summarised as follows:

- The method for measuring the workpiece temperature in double face grinding with planetary kinematics was developed. A series of experiments was performed on Al_2O_3 ceramic workpieces using full-featured digital temperature loggers. Measurement of the workpieces temperature in the considered machining system has not been reported in the literature yet.
- The empirical model to predict the change in temperature of Al_2O_3 ceramic workpieces while processing was determined using the experimental results. The workpiece temperature changes showed a progressively increasing behaviour towards a maximum value. One of the coefficients of the proposed nonlinear regression model of the temperature change is a horizontal asymptote of the mathematical function. This asymptote can be assumed as the theoretical maximum temperature increase that can occur during grinding under given technological parameters.
- As expected, higher removal rates $\Delta\dot{h}_w$ resulted in the shorter processing time t_p and in larger temperature changes. A mean cutting speed had a smaller effect on the workpiece temperature at the comparable removal rates and coolant flows. For the cutting speed $\bar{v}_c = 10$ m/s, the measured temperatures were slightly lower than in the corresponding experiments carried out with a mean cutting speed of $\bar{v}_c = 15$ m/s. This was also reflected by slightly lower values of a model coefficient b_1 for $\bar{v}_c = 10$ m/s. In the light of the above, a mean cutting speed along with the actual tool cutting performance influenced by the tool wear must be considered for the prediction of a temperature increase.
- In grinding experiments for $\bar{v}_c = 10$ m/s and $\bar{v}_c = 15$ m/s, a decrease in the cutting performance of the tool reduced the material removal rate $\Delta\dot{h}_w$, leading to the lower workpiece temperature and even to its decrease after reaching the maximum temperature. The time at which the temperature started to decrease may indicate the necessity to perform the conditioning process of the worn tool.
- The experimental data showed that the coolant flow rate has an essential influence on the workpiece temperature. It was examined for the highest mean cutting speed $\bar{v}_c = 25$ m/s. Reducing the coolant flow rate by half caused the a reduction in the distribution of heat into the coolant and as a result a significant temperature increase. That was reflected also by the

values of the model coefficient b_1 . The coefficient b_1 for the experiment run at the flow rate $\dot{Q}_{lub} = 20$ l/min was approximately twice as high as the coefficient b_1 for the experiment run at the flow rate $\dot{Q}_{lub} = 40$ l/min. The flow rate of the coolant, which is one of the heat absorbers in the grinding zone, could be reduced if the workpiece temperature started to decrease.

Accurate curve fitting enables utilisation of the proposed method in the further scientific research and in the industrial practice. The main areas of the potential use of this method, arising from the possibility of obtaining temperature data are as follows:

- A better selection of technological parameters can be made to avoid too high temperature increase during machining. The temperature change can be calculated on the basis of the model as a function of the processing time and also the theoretical maximum temperature increase is given directly as a coefficient b_1 of a developed model.
- The energy consumption can be reduced by choosing the adequate coolant flow rate when the intensive cooling is not necessary to avoid thermal defects. The intensive cooling has so far been the only method to avoid the occurrence of thermal defects, especially in case of brittle ceramic materials. In industrial practice the grinding process is usually carried out with smaller material allowances that require shorter processing times comparing to the performed experiments. In case of bigger allowances requiring the longer processing time, the temperature should not exceed the theoretical maximum value predicted by a proposed model. This is due to a typical decrease in the cutting performance of the grinding tools during longer processing without the tool conditioning.
- The necessity for a tool conditioning process could be indicated at a given time of machining. Tool conditioning carried out periodically restores the cutting performance of the grinding tool but in some cases it might be carried out less frequently in order to reduce the tool wear. This will require the detailed investigation on the influence of the parameters of a conditioning process on the workpiece temperature and on the surface finish.
- The experimental temperature data can be obtained in other abrasive processes for which only theoretical temperature models exist, due to measurement difficulties and limited accessibility to the working zone. This will allow validation of the existing numerical models of the temperature increase in processes for finishing flat surfaces such as lapping, polishing and grinding with lapping kinematics.

ACKNOWLEDGEMENTS

Computations carried out with the use of software and computers from Academic Computer Centre in Gdansk - TASK (<http://www.task.gda.pl>). Experiments were partially financed by Polish budget funds for science as a research project N N503 157638.

REFERENCES

- [1] Wan, L., Dai, P., Li, L., Deng, Z., & Hu, Y. „Investigation on ultra-precision lapping of A-plane and C-plane sapphires.” *Ceramics International*, 49 (2019) 9, pp. 12106-12112.
- [2] Deja, M. „Simulation Model for the Shape Error Estimation During Machining With Flat Lapping Kinematics”. *ASME 2010 International Manufacturing Science and Engineering Conference*, Vol. 1 (2010), pp. 291-299.
- [3] Barylski, A., & Deja, M. „Wear of a Tool in Double-Disk Lapping of Silicon Wafers”. *ASME 2010 International Manufacturing Science and Engineering Conference*, Vol. 1 (2010), pp. 301-307.
- [4] Uhlmann, E., List, M., Patraschkov, M., & Trachta, G. „A new process design for manufacturing sapphire wafers.” *Precision Engineering* 53 (2018), pp. 146-150.
- [5] Funck, A. (1994). “Planschleifen mit Läppkinematik.” PhD-Thesis, Technische Universität Berlin.
- [6] Uhlmann, E., Ardelt, T., Daus, N. (1998). “Kinematische Analyse von Zweiseibenmaschinen.” *Werkstattstechnik*, 88 (6), pp. 273 - 276.
- [7] Rußner, C. (2008). “Präzisionsplanschleifen von Al₂O₃-Keramik unter Produktionsbedingungen.” PhD-Thesis, Technische Universität Dresden.
- [8] Uhlmann, E., Hoghé, T. “Wear reduction at double face grinding with planetary kinematics.” *Production Engineering* , 6 (2012) 3, pp. 237 - 242.
- [9] Uhlmann, E., Hoghé, T., Tirier, K. „Abschlussbericht des InnoNet-Projekts HOPPLA Entwicklung einer wirtschaftlichen Bearbeitungstechnologie für das Hochgeschwindigkeits- und Hochleistungsplanschleifen mit Planetenkinematik.“ Berlin, Hannover: Techn. Univ.; Technische Informationsbibliothek u. Universitätsbibliothek, 2010.
- [10] Uhlmann, E., Hoghé, T., Kleinschmitker, M. „Optimierungspotentiale beim Doppelseitenplanschleifen mit Planetenkinematik“. *Proceedings of the 1st Schweizer Schleif-Symposium*, Zurich, Switzerland, 18.01 - 20.01.2016.

- [11] Uhlmann, E., Kleinschnitker, M., Hoghé, T. "Tool Wear model for double face grinding with planetary kinematics." In: Proceedings of the ASME 2014 International Manufacturing Science and Engineering Conference, Detroit, 09.06. - 13.06.2014.
- [12] Uhlmann, E., Hoghé, T., Kleinschnitker, M. "Grinding wheel wear prediction at double face grinding with planetary kinematics using analytic simulation." *The International Journal of Advanced Manufacturing Technology*, 69 (2013) 9-12, pp. 2315 - 2321.
- [13] Uhlmann, E., Hoghé, T., Kleinschnitker, M. "Doppelseitenplanschleifen mit Planetenkinematik." *Werkstattstechnik online*, 204 (2014) 6, pp. 368 - 373.
- [14] Uhlmann, E., List, M., Lichtschlag, L. „Stellgrößen beim Doppelseitenplanschleifen mit Planetenkinematik.“ *Zeitschrift für wirtschaftlichen Fabrikbetrieb ZwF* 111 (2016) 7-8, pp. 399 - 402.
- [15] Brinksmeier, E., Aurich, J.C., Govekar, E., Heinzl, C., Hoffmeister, H.-W., Klocke, F., Peters, J., Rentsch, R., Stephenson, D. J., Uhlmann, E., Weinert, K., Wittmann, M. "Advances in modelling and simulation of grinding processes." *CIRP Annals – Manufacturing Technology*, 55 (2006) 2, pp. 667 - 696.
- [16] Malkin, S., Guo, C. "Thermal analysis of grinding." *CIRP Annals - Manufacturing Technology*, 56 (2007) 2, pp. 760 - 782.
- [17] Choudhary, A., Naskar, A., & Paul, S. „Effect of minimum quantity lubrication on surface integrity in high-speed grinding of sintered alumina using single layer diamond grinding wheel." *Ceramics International*, 44 (2018) 14, pp. 17013-17021.
- [18] Jingliang, J., Peiqi G., Shufeng S., Dexian W., Yuling W., Yon Y. „From the microscopic interaction mechanism to the grinding temperature field: An integrated modelling on the grinding process." *International Journal of Machine Tools & Manufacture* 110 (2016) pp. 27 - 42.
- [19] Yang, Z., Zhu, L., Lin, B., Zhang, G., Ni, C., & Sui, T. „The grinding force modeling and experimental study of ZrO₂ ceramic materials in ultrasonic vibration assisted grinding." *Ceramics International* 45 (2019) 7, pp.8873-8889.

- [20] Kuriyagawa, T., Syoji, K., Ohshita, H. "Grinding Temperature within contact arc between wheel and workpiece in high-efficiency grinding of ultrahard cutting tool materials." *Journal of Materials Processing Technology*, 136 (2003) 1-3, pp. 39 - 47.
- [21] Hadad, H., Sharbati, A. "Thermal Aspects of Environmentally Friendly-MQO grinding Process" *Procedia CIRP* 40 (2016), pp. 509 - 515.
- [22] Pang, J., Li, B., Liu, Y., Wu, C. "Heat flux distribution model in the cylindrical grinding contact area." *Procedia Manufacturing*, Volume 5, 2016, pp. 158 - 169.
- [23] Upadhyaya, R. P., Malkin, S. "Thermal aspects of grinding with electroplated CBN wheels." *Journal of Manufacturing Science and Engineering*, 126 (2004) 1, pp. 107 - 114.
- [24] Kim, N. K., Guo, C., Malkin, S. "Heat Flux Distribution and Energy Partition In Creep-Feed Grinding." *Annals of the CIRP*, 46/1 (1997), pp. 227 - 232.
- [25] Bulsara, V. H., Ahn, Y., Chandrasekar, S., Farris, Th. N. "Polishing and lapping temperatures." *Journal of Tribology*, 119 (1997) 1, pp. 163 - 170.
- [26] Horng, J. H., Jeng, Y. R., Chen, C. L. "A model for temperature rise of polishing process considering effects of polishing pad and abrasive." *Journal of Tribology*, 126 (2004) 3, pp. 422 - 429.
- [27] Uhlmann, E., Sammler, C., Hoghé, T., Borsio Klein, T. "Einsatz innovativer Schleifverfahren macht Hochleistungsbearbeitung wirtschaftlicher." In: *Maschinenmarkt* Ausgabe 30 (2009), pp. 22 - 26.
- [28] Oliveira, J. F. G., Silva, E. J., Guo, C., Hashimoto, F. "Industrial challenges in grinding." *Annals of the CIRP* (2009) 58, pp. 663 - 680.
- [29] Maxim Integrated Products, Inc. "Data Sheet DS1922L/DS1922T iButton Temperature Loggers with 8KB Datalog Memory." San Jose, CA, United States. 2015. URL: <https://www.maximintegrated.com/en/products/digital/data-loggers/DS1922L.html> (access: 2018-03-26).

[30] Sanchez, L. E. A., Jun, N. Z. X., Fiocchi, A. A. “Surface finishing of flat pieces when submitted to lapping kinematics on abrasive disc dressed under several overlap factors.” *Precision Engineering*, 35 (2011) 2, pp. 355 - 363.

[31] Korzyński M. „Methodology of the experiment. Planning, implementation and statistical analysis of the results of technological experiments”, in Polish “Metodyka eksperymentu. Planowanie, realizacja i statystyczne opracowanie wyników eksperymentów technologicznych”, Publisher House: Wydawnictwo WNT (2018), pp. 277.