

# A CONCEPT DESIGN OF DIESEL – HYDRAULIC PROPULSION SYSTEM FOR PASSENGER SHIP INTENDED FOR INLAND SHALLOW WATER NAVIGATION

Czesław Dymarski  
Gdańsk University of Technology, Poland

## ABSTRACT

*This paper presents an analysis of environmental and technical conditions necessary for working out a possibly most favourable propulsion system for a two – segment passenger ship intended for navigation between Berlin and Kaliningrad. There are presented various types of propulsion systems for small ships as well as analyzed their possible applications and consequences. In this work there were taken into account system’s reliability, efficiency, dimensions, mass and costs of manufacturing, assembling and possible replacing the system components as well as an impact on maneuverability and natural environment. With taking into account the above mentioned criteria it was finally found that the diesel-hydraulic system fitted with two azimuthal ducted solid propellers is the most favourable. There are also presented a schematic propulsion and control diagram, three-dimensional arrangement drawing of system components as well as assembly drawing of the designed azimuthal propulsion system.*

**Keywords:** ship propulsion systems, hydraulic drive and control, azimuthal propulsion systems

## INTRODUCTION

In the contemporary world economy, water transport, especially intercontinental one plays crucial role as it makes practically unlimited transport of different goods in different forms under the lowest cost and possibly lowest unfavourable influence on natural environment, possible. The favourable features deal also, however to a lesser degree, with inland waterway transport. In the West European countries this mode of transport has a high share in total amount of transport. In Poland, because of insufficiently developed inland waterways, this mode of transport plays a marginal role, and the worse, its share in the overall goods transport turnover in the years 2000–2014–2015 decreased from 0,8 to 0,4% and 0,3%, respectively[1]. However it should be hoped that owing to EU transport policy a chance appears for restoring proper navigation features of Polish inland waterways and an appropriate position of Polish inland waterways navigation, which would mitigate the

today negative consequences of transport development, i.e. a distinct domination of car transport both in carrying goods and passengers.

An European document presently in force which indicates directions for transport development, including inland waterways transport, is the so called “White Book” [2], in which crucial challenges for the transport system up to 2050 are diagnosed. There is taken into account a. o. the necessity of unification of transport systems of West and East Europe, limitation of dependence on crude oil as well as reduction of emission of greenhouse-effect gases. Moreover, there is also postulated to shift long-range road transport of over 300 km in distance to other transport modes, e.g. water or railway transport, in the amount of 30% up to 2030.

The present Polish government plans to build in Poland a network of “water highways”. The international waterways have to be developed on the rivers: Vistula, Bug, Oder, Warta and Notec. Cost of the undertaking is estimated at abt. 70–90 billion zlotys. On 6.03.2017, Andrzej Duda, the

Polish President signed the ratification act concerning the European agreement on the matter of main inland waterways of international importance (AGN). The convention makes it possible for its partners to apply for river development funds. Hence, favourable conditions are formed to undertake works on improving technical state of waterways as well as designing and building modern, more efficient transport means, more suitable for navigation over Polish inland waterways.

It should be underlined that already in the years 2003–2006 similar research and design projects were carried out by the team of the Ocean Engineering and Ship Technology Faculty, Gdansk University of Technology, in the frames of the EU-supported EUREKA project INCOWATRANS – E!3065 (*A NEW GENERATION OF ENVIRONMENT FRIENDLY INLAND & COASTAL SHIPS FOR POLISH EAST-WEST WATERWAYS*).

The project was conducted in cooperation with Warsaw University of Technology and Wrocław University of Technology, Polish Maritime Institute, SINUS design office as well as the firm INFERT GmbH Rostock. And, after initial analyzes Gdansk University of Technology was assigned to work out a design project of two-segment passenger ship intended for inland waterways navigation on the route between Berlin and Kaliningrad.

One of the most important and simultaneously difficult tasks was to design a propulsion system most suitable for the ship in question. A decisive difficulty of the task resulted from the fact that the depth of Polish sections of the intended route did not exceeded 1,2 m in some spots. To solve the problem it was necessary to work out and analyze several variants of the system in order to select finally the most appropriate. In view of the fact that since that time the state of the waterways has not been improved and the development plans still cover also inland waterways transport, this author decided to remind the systems which were earlier considered the most favourable in the respect of many important criteria, and to analyze their usefulness.

## ENVIRONMENTAL AND TECHNICAL CONDITIONS FOR THE PROPULSION SYSTEMS

While designing inland navigation ships it is necessary to be aware of technical state of an intended navigation route, particularly its depth, dimensions of locks, minimum clearance under bridges to be met along the route as well as other factors, including ecological. The enumerated factors decisively impacts construction of the ship and its propulsion and steering systems, in particular.

For the selected route, apart high environmental requirements, values of three most important characteristic parameters were as follows:

- minimum water depth – 1,2 m,
- length of the shortest lock – 60 m,
- minimum under bridge clearance over mean water level – 3,87 m.

With taking into account the above data, a general concept of the ship consisting of two mutually connected segments, namely: hotel barge and its pusher of the following technical parameters, was worked out:

- length and breadth of each segment  $L \times B = 56 \times 9$  m,
- draught  $T = 1,0$  m,
- ship displacement at the draught  $T = 1$  m  $D_{1.0} = 440$  t,
- designed speed of the ship at the draught  $T = 1$  m  $V = 14$  km/h,
- effective propulsion power demand  $P = 300$  kW.

## ANALYSIS OF THE CONSIDERED PROPULSION SYSTEMS AND SELECTION OF THE MOST FAVOURABLE VARIANT

The very small draught of the ship is an important limitation in selecting an appropriate main propulsion system. The condition practically eliminates a system with cycloidal propellers placed under ship hull, whereas it rather prefers

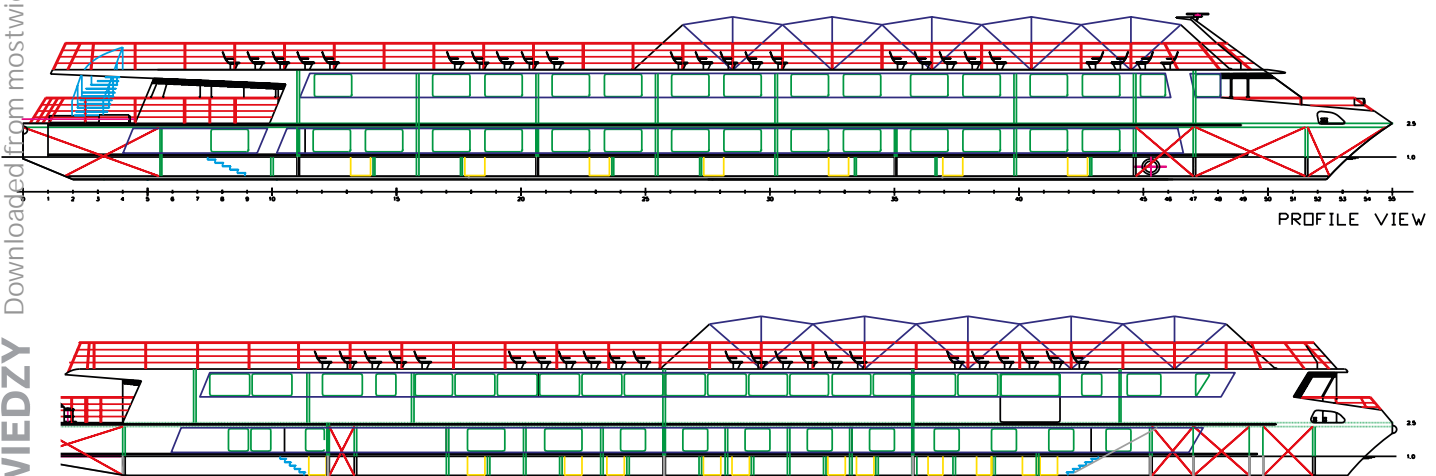

Fig. 1. Concept design of the two-segment inland navigation ship [3]

waterjet propulsion which provides high manoeuvrability properties without danger of hitting water bottom with screw propeller blades. Such propulsion system is not favourable from the point of view of ecology. The sucking out of large amount of water from under ship bottom and fast discharging it off cause that the water bed structure and surrounding biological life may be damaged. The factor is as much important that the designers decided to resign from applying the waterjet propulsion.

Therefore the systems fitted with a typical screw propeller were considered. When applying such typical system with a single screw propeller working in under-cavitation zone its diameter necessary to execute the ship's tasks should be greater than 1.4 m. In view of the small draught of the ship this diameter value is not acceptable. Hence it was concluded that to be able to fulfil the assumptions it is necessary to apply a twin-propeller system. Such solution would allow to effectively reduce diameters of screw propellers to 0.83–0.85 m under the condition of placing them within Kort nozzles, maintaining their capacity of transmitting the assumed power. Based on the preliminary documentation of the unit in question it turned out that the outer diameter of the nozzle would reach 1,045 m, which means that it would be somewhat greater than the nominal value of ship draught of 1 m, but it seems not to be a significant obstacle if only an appropriate forming the ship hull is used.

Such solution has many merits. The twin-propeller system ensures a greater manoeuvrability and reliability. Placing the propellers in nozzles substantially reduces danger of hitting the waterway bed with propeller blades, which usually results in blade damage and necessity of replacing the propeller. Such system also mitigates unfavourable impact of propeller race onto waterway bed.

A next issue which should be analyzed was selection of an optimum type of the propeller, namely, whether to use a solid screw propeller or that with controllable pitch. In the case of driving the propeller with a diesel engine through a reduction gear the application of a controllable pitch propeller makes engine operation with practically constant and optimum rotational speed possible in different navigation conditions, owing to this efficiency of the whole system is the highest. Though it is paid with a much greater complexity of propeller boss mechanism and necessity of application of a separate hydraulic system for driving and controlling the mechanism. This enlarged complexity of the propellers results in dropping their reliability and increasing costs of investment and operation.

An increased reliability and reduced complexity of the system may be reached by using a constant pitch propeller. However for the maintaining of a relatively high efficiency of the propulsion system it is necessary to ensure possibly fluent change, in value and direction, of propeller shaft rotation, that may be as simple as possible executed with the use of a propulsion system fitted with a hydrostatic or electric gear. However it should be stressed that in such gears energy form change occurs two times: first from mechanical energy form on combustion engine shaft to hydraulic or electric one and

then back to mechanical one on propeller shaft. Unfortunately, every change in energy form is associated with a dozen or so percent of energy loss, but there are also reached considerable profits. One of them is, in particular, easiness in transmitting electric energy as well as hydraulic one, that eliminates the necessity of applying long propulsion shafts and provides a large freedom in arranging, in the most favourable way, combustion engines and other heavy power plant equipment. This is a very valuable feature especially for the designed ship intended for navigation in shallow inland waters because it allows to distribute uniformly loads over ship hull and avoid the undesired overloading of ship stern.

Another profits are available by substituting the solid nozzle with rotatable one.

It allows to resign from a traditional rudder and, as a result, to reduce dimensions and weight of steering devices at simultaneous improving ship's manoeuvrability. Application of hydraulic drive and control to nozzle rotation mechanism is most profitable, it means such solution as that commonly used for ship steering devices. It results from the necessity of achieving a precise but relatively slow motion of laying rudder blade or nozzle, maintaining a perfect but simple protection against overloading. The driving of rudder post may be obtained in a simple and cheap way by using hydraulic cylinders and lever systems or complex and more expensive, but compact, mechanisms with hydraulic motors, planetary gear and friction brake. Nevertheless this type of mechanism, but fitted with electric motors, can be found also in diesel–electric propulsion systems.

The next step aimed at possible reduction of the area occupied by power plant devices and their mass is the application of two azimuthal propellers (rotatable thrusters) with round rotation angle ( $360^\circ$ ) of propeller column. Such solution is advantageous because it leads to a higher manoeuvrability of the ship and elimination of relatively long and slender horizontal propulsion shafts which usually require an additional support bearing outside the ship hull.

In view of the low water depth of the discussed navigation route of the designed ship, it was decided to place the propellers in a simple cage structure fixed with the ship hull (Fig. 2) in order to better protect them against damaging in case of hitting the river bed. In the middle of the lower transverse beam of the structure, the body and bushing of the slide bearing of the rotatable propeller column are placed (Fig. 4).

Also, different variants of energy sources were considered. It was concluded that the basic, most profitable, reliable and commonly used source of energy is a light-oil combustion engine. Application of a hybrid propulsion system combined with an additional supply source of energy, e.g. electricity from photovoltaic cell batteries, is not very effective in our climate and it would moreover require to complicate greatly the propulsion system and lead to additional costs and space [5]. Possible application of a compressed gas fuel (methane) was also considered, but one resigned of the alternative in view of necessity of keeping gas in pressure cylinders, which is potentially dangerous.

Based on the above presented factors and conditions it was decided to work out concept designs of two, most technically justified (acc. this author's opinion) solutions of the propulsion systems fitted with two rotatable thrusters, namely:

- diesel-electric system with typical asynchronous squirrel-cage electric motors and frequency converters which make it possible to fluently change rotational speed of a constant pitch screw propeller, and
- diesel-hydraulic system with hydrostatic gear.

The comparative analysis of both the above specified systems for concretely chosen particular units and elements with taking into account their efficiency, mass, dimensions and investment cost was presented in the work [6]. As a result of this analysis it was concluded that a diesel-hydraulic system presented in the further part of this work would be more favourable.

## CONCEPT DESIGN OF DIESEL-HYDRAULIC PROPULSION SYSTEM FOR PUSHER

Below, in Fig. 2 there is presented a schematic diagram of a hydraulic drive and control system with description its units and elements but without giving precise data on each of the selected units.

The system consists of two identical mutually independent systems. Each of them is driven by means of the high-speed piston self ignition engine I, which, through the elastic coupling II, drives the system of the two oil pumps 2 and 3, and also, through the mechanical gear III, the electric generator IV and the oil pump 4.

The pump 3 is a multi-plunger variable-delivery pump, which, together with the constant delivery pump 2 fixed with it, and the control block V associated with it, constitutes the main source of energy oil which supplies the constant absorbing capacity hydraulic motor 11. The motor, through the toothed bevel gear, drives the constant pitch propeller placed in the rotatable nozzle of the column of the azimuthal propeller XIV. In this case the application of the constant pitch propeller was justified due to possible continuous control of rotational speed and direction of the hydraulic motor. This is executed by changing the capacity and oil pressing direction of the pump 3. To this end, there is used the hydraulic servomechanism of the pump, which is consisted of the hydraulic actuator 5 and the electromagnetically controlled proportional distributor 6. The control system of the variable delivery pump 3 is supplied from the constant delivery pump 2. The oil from this pump is delivered through the non-return valve 27 to the filter block behind which it is distributed into four branches:

- to supply the proportional distributor 6 in the block VI,
- to supply the block VII intended for refreshing and ensuring the main system of the pump,
- to limit the lower value of control pressure by connecting with the overflow valve 15,
- to limit the pump capacity to protect the block VIII against overloading.

During regular operation the filtrated oil of an appropriate temperature flows from the control system of the pump through one of the blocks VII and runs into an instantaneously low pressure branch of the main circuit of the variable-capacity pump. Simultaneously, from this branch the same amount of oil, now of a higher temperature, must be removed. The oil flows out through the three-position distributor 10, overflow valve 19 and filter 21 into the oil tank 1. The distributor 10 is controlled by the pressure in the branches of the main circuit of the pump and during its operation always connects the low-pressure branch with the overflow valve 19 whose opening pressure is set up to a value a little lower than that on the overflow valve 15.

The overflow valves 18 located in the block VII serve as emergency valves, preventing both the main branches of the pump against overpressure.

The ship propeller of each of the azimuthal propellers is driven, through the toothed intersecting axis gear of constant reduction ratio, by the hydraulic constant absorbing capacity motor 11 located in the propeller ventral pod. This motor is placed vertically in the ship hull over the propeller and coupled directly with the vertical shaft of the above mentioned gear.

The ship steering functions are executed by rotating the propellers by an arbitrary angle in respect of vertical axis. To this end, there were used two hydraulic constant absorbing capacity motors 12 driving the propeller column through toothed reduction gears. The motors are fed from the constant capacity pump 4 through the non-return valve 27 and the electromagnetically controlled three-position distributor 7 and the block XII with the controlled non-return valves 13. The valves prevent the propeller column against rotation under external loads in case of a pressure drop in the system. If the above mentioned external load appears excessively large, e.g. as a result of hitting the river bed, then one of the two overflow valves 14 located in the block XIII will be opened, that will make the propeller rotation at the rotating moment greater by abt. 20% from the rated one, possible.

The application of two motors and the reduction gear was mainly justified by a desire of reducing dimensions so as to make it possible to place all the three motors in one common plane with maintaining the selected crown bearing of the propeller column. Since in the symmetrical system two smaller motors allow to greatly reduce the loads and, as a result of that, also the dimensions of the toothed gear. The motors are supplied in parallel through the dividers 9 which have two-position and are electromagnetically controlled. They allow to cut out hydraulically a given motor from supply circuit while simultaneously connecting both of its supply pipes together. Owing to this, it is possible to drive the propeller rotation mechanism by only one hydraulic motor while the other one serves as a pump operating for overflow at a slight loss of power. It should be however stressed that the possibly available rotation moment of the propeller will be lower by almost a half from that rated, however it seems to be sufficient for ship course steering during regular long-range navigation.

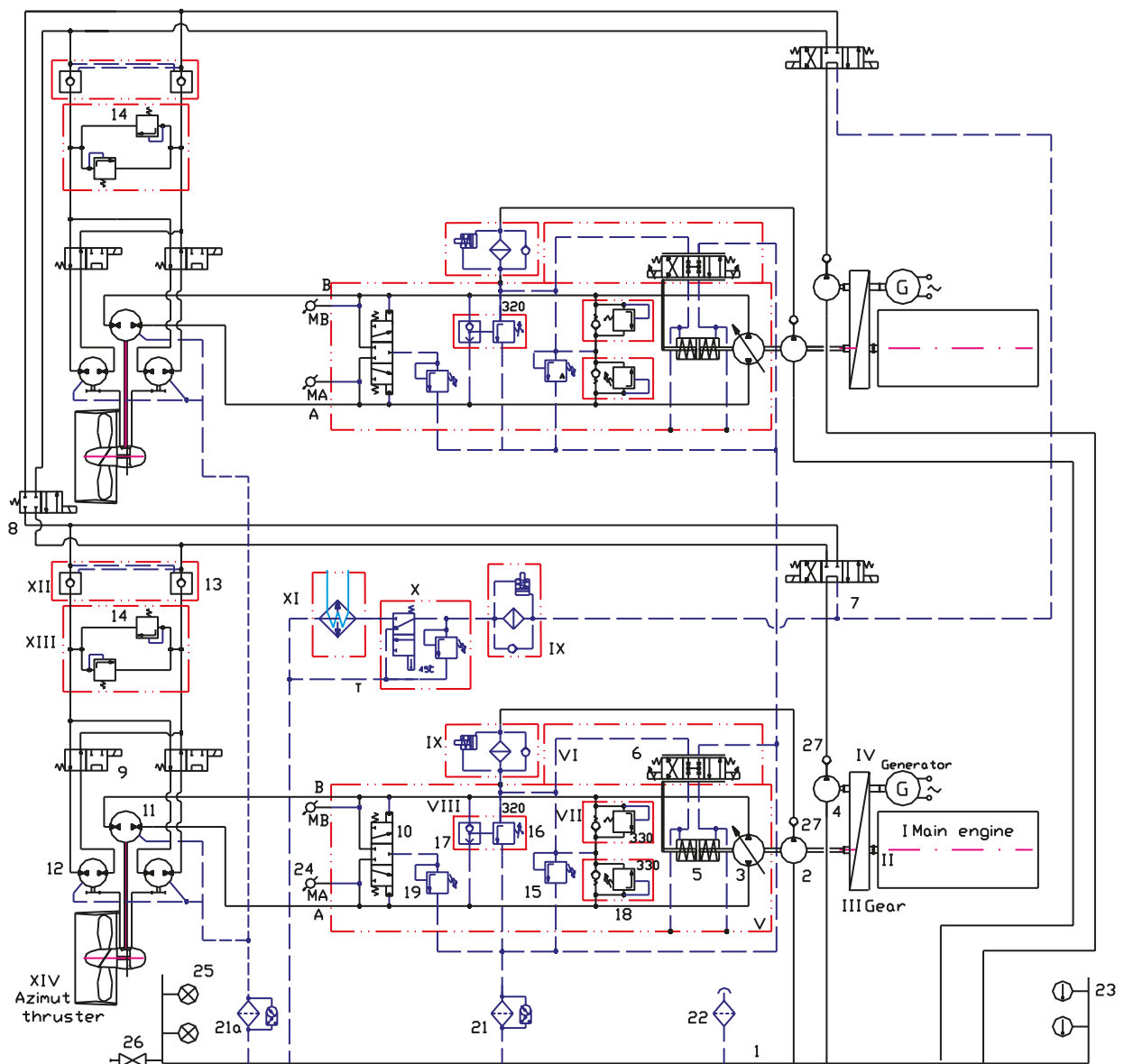

Fig. 2. Schematic diagram of a drive and control system with hydrostatic gear, intended for inland waterway ship

In view of that the duration time of manoeuvres with the use of rotation of the propeller column is only a small part of the whole navigation time, the circuit in question was used also for purifying and cooling the oil in the tank. In the time between manoeuvres the distributor 7 is in the middle position cutting off this way hydraulically the propeller column driving motors from supply and directing all the output of the pump 2 to the block IX – for oil filtering, block X – for temperature control and possibly to the block XI – for oil cooling and further to the tank 1. During execution of manoeuvres the oil reconditioning process is also carried out, but this is the oil coming back from the hydraulic motors 12 which flows into the above mentioned blocks IX, X and XI.

The circuits of the propeller column rotation mechanism of both the propulsion systems can be mutually connected by changing the set position in the two-position electromagnetically controlled distributor 8. This way, it is made possible to control rotation of the both propellers, but

with the speed lower by a half, also during operation of only one propulsion system.

The oil tank 1, common for the both propulsion systems, is equipped with the inlet filter 22, temperature sensors 23, oil level gauges 25 and cut-off valve 26 for oil discharging. Oil leakages from hydraulic motors are led through the outflow filter 21 to the tank 1.

## ARRANGEMENT OF PROPULSION SYSTEM'S CRUCIAL UNITS

The arrangement of particular units of the worked out propulsion system and other crucial power plant elements are schematically shown in Fig. 3.

To simplify the drawing, the oil piping and other minor equipment elements especially those of hydraulic oil tank including various valves, filters, oil cooler and temperature and oil level sensors, were omitted.

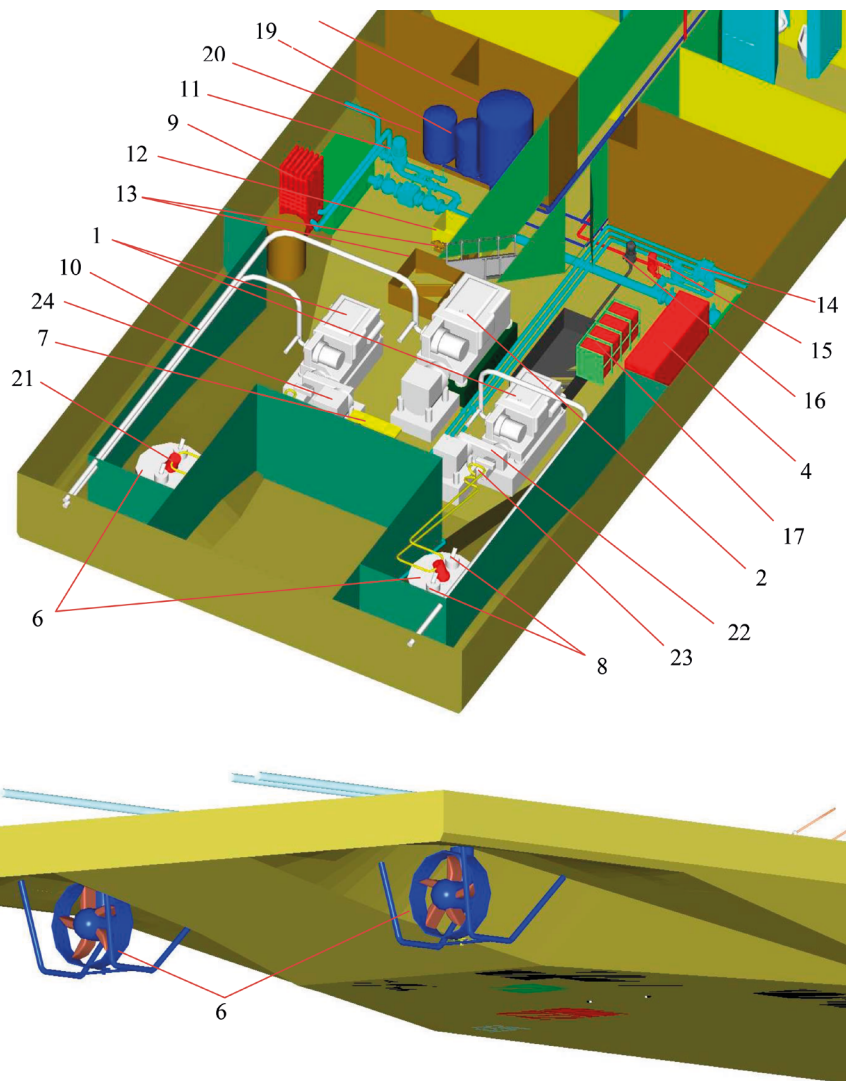

Fig. 3. Simplified arrangement drawing of crucial units of diesel-hydraulic propulsion system as well as other power plant devices of an inland navigation ship.

Notation: 1 – Combustion engines, 2 – Electric generating set, 4 – Cabinets with electric equipment, 6 – Azimuthal propellers, 7 – Hydraulic oil tank with supply system, 8 – Hydraulic motors with planetary gears for driving rotation mechanism, 9 – Central cooler, 10 – Exhaust gas pipes, 11 – outside water pump, 12 – Lubricating oil tank and transport pump, 13 – Fuel oil tank and transport pump, 14 – Ballast pump, 15 – Fire pump, 16 – Bilge pump, 17 – Electric accumulator batteries, 18 – Hydrophore tank, 19 – Electric water heater, 20 – Water heater, 21 – Hydraulic propeller driving motors, 22 – Mechanical reduction gear, 23 – Hydraulic variable capacity pump, 24 – Electric generating set

## PRELIMINARY DESIGN OF AZIMUTHAL PROPELLER WITH DUCTED SOLID SCREW PROPELLER

The designing of azimuthal propeller was one of the difficult design tasks during execution of this project. Initially it has seemed that an appropriate propeller would be available on the market, but it soon has turned out that the available azimuthal propellers could not fulfil the assumed technical conditions for the ship in question. It was then decided to design a special propeller for that ship with taking into account rules of classification societies, first of all of Polish Register of Shipping. In a short time was prepared a preliminary design of such propeller whose cross-sectional drawing is presented in Fig. 4. Two constructional versions which only slightly differ to each other in form and transverse dimensions of elements for fastening the propeller in the ship's

hull, were prepared. The variant shown in Fig. 4 is adjusted to its assembling from the top. For this reason in the propeller fastening area suitably large openings in the deck and bottom of the ship should be provided in order to make it possible to lower the propeller with the use of a line into its fastening place. After installation of the propeller, a removable cover will be mounted on the opening in the deck. The other variant of the propeller is intended for the installing it upward from an outboard position below the ship bottom. Its merits consist in smaller diameters of assembly plate and opening in the ship bottom as well as a lack of making any opening in the deck. An important drawback is a much more difficult assembling operation for which ship docking is necessary with a properly large distance between dock's deck and ship's bottom, as well as necessity of preparation of a removable transverse beam in the cage protecting the propeller, in which the slide bearing of the propeller column with the nozzle is fastened.

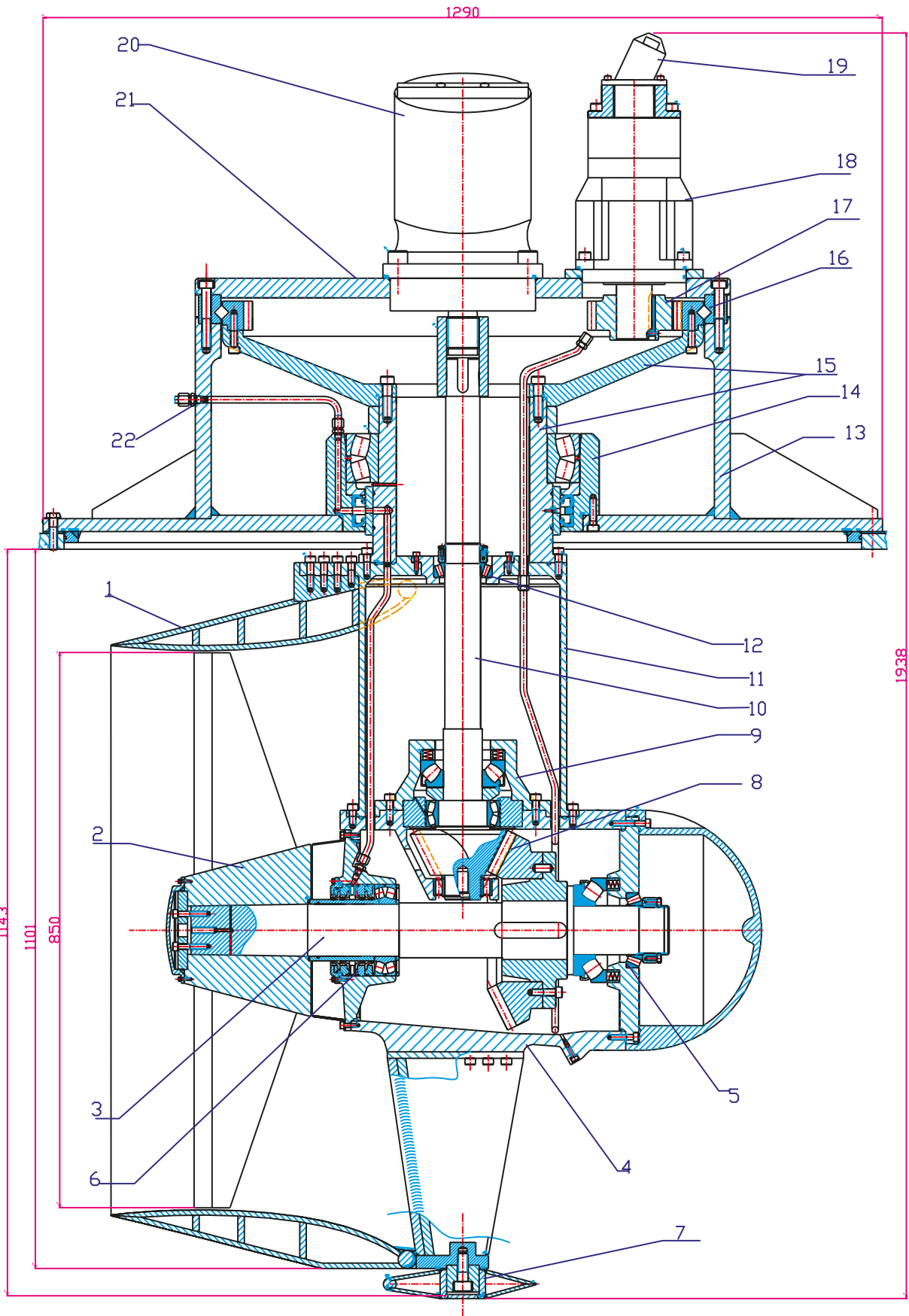

Fig. 4. Assembly drawing of the designed azimuthal propeller with solid screw propeller and hydraulic drive, showing its major units [4].

Notation: 1 – nozzle, 2 – screw propeller, 3 – propeller shaft, 4 – pod, 5 – front shaft bearing unit, 6 – rear shaft bearing and sealing unit, 7 – nozzle bearing in protection beam, 8 – angular gear, 9 – lower propulsion shaft bearing unit, 10 – propulsion shaft, 11 – lower part of the column, 12 – upper propulsion shaft bearing unit, 13 – propeller body, 14 – column bearing unit, 15 – upper part of the column, 16 – crown bearing, 17 – column drive bearing, 18 – planetary gear, 19 – column drive hydraulic motor, 20 – propeller drive hydraulic motor, 21 – body cover, 22 – lubrication system piping



## FINAL REMARKS

The concept design, presented in this paper, of the propulsion system for the pusher of two-segment passenger ship intended for Berlin–Kaliningrad waterway route was selected during a final seminar held in 2007 with participation of all consortium members, project reviewers and representatives of Bydgoszcz Shipping Co. However the project was not finally put into execution due to a lack of financial resources. Today, as already mentioned, the dynamic economic development of Poland and resulting fast increase of demand for transport services have caused from the side of the Authority a greater interest in using inland waterways transport.

It should be also stressed that many research centres and technical universities have conducted investigations on developing construction and operation of hydraulic propulsion units and elements with taking into account properties of working medium [7], [8], as well as changeable service conditions, including ambient temperature [9], [10]. There have been also conducted investigations on more and more efficient propulsion systems, including hybrid diesel-electric ones intended for inland navigation ships. Even to mention the design projects and tests of two small ships with electric propulsion systems fed from photovoltaic cells, recently worked out by a team of Ocean Engineering and Ship Technology Faculty, Gdansk University of Technology, [11], [12].

Summing up, this author hopes that the information presented in this paper may be helpful for designers and researchers of novel inland navigation ships in their making important design decisions.

## REFERENCES

1. *Inland waterways transport in Poland in 2016* ( in Polish). Signalling issue. Polish main statistical authority. Warsaw, 25 August 2017.
2. White Paper 2011. *Roadmap to a Single European Transport Area – Towards a competitive and resource efficient transport system*, European Commission, Brussels, 28 March 2011.
3. W. Hołowko, J. Michalski, K. Rosochowicz: *A design concept of ecological tourist – passenger ship intended for Berlin-Królewiec (Kaliningrad) inland waterway service*. Polish Maritime Research, Special Issue 2006/S2.
4. Dymarski Cz.: *A propulsion system with hydrostatic gear intended for inland navigation ship* (in Polish). In monograph on “Research, construction and production of hydraulic systems”, Cylinder 2006, 26–28 September 2006.
5. Dymarski Cz., Rolbiecki R., Litwin W., Piątek D.: *A concept design of propulsion system and main installations of inland navigation ship*. A chapter of the final report on the project INCOWATRANS – 2006.
6. Dymarski Cz., Rolbiecki R.: *Analysis of two Design Kinds of Propulsion for an Inland Vessel*. *Explo-Diesel & Gas Turbine '2008'*, 5<sup>th</sup> International Scientifically-Technical Conference.
7. Śliwinski P.: *The influence of water and mineral oil on mechanical losses in the displacement pump for offshore and marine applications*. Polish Maritime Research. Vol. 25, SI (97), 2018.
8. Śliwinski P.: *The influence of water and mineral oil on volumetric losses in a hydraulic motor*. Polish Maritime Research, Vol. 24, SI (93) 2017.
9. Jasinski R.: *Influence of design of hydraulic components on their operation in low ambient temperatures*. Key Engineering Materials, Vol. 490, 2012.
10. Jasinski R.: *Problems of the starting and operating of hydraulic components and systems in low ambient temperature. Part IV. Modelling the heating process and determining the serviceability of hydraulic components during the starting-up in low ambient temperature*. Polish Maritime Research, No. 3, (95) 2017.
11. Litwin W., Leśniewski W., Kowalski J.: *A proposed conversion of propulsion system for inland navigation passenger ship – from conventional to hybrid one* (in Polish). *Napędy i sterowanie* 5/ 2017.
12. Kowalski J., Leśniewski W., Litwin W.: *Multi-source -supplied parallel hybrid propulsion of the inland passenger ship STA.H. Research work on energy efficiency of a hybrid propulsion system operating in the electric motor drive mode*. Polish Maritime Research No. 3, 2013.



## CONTACT WITH THE AUTHORS

**Czesław Dymarski**

*e-mail: cpdymars@pg.gda.pl*

Gdańsk University of Technology

Narutowicza 11/12

80-233 Gdansk

**POLAND**