

Optical sensor of a person sitting on a chair and dressed in multi-layered clothes vital signs monitoring

1st Adam Bujnowski

*Biomedical Engineering Department,
Faculty of Electronics, Telecommunications
and Informatics, Gdansk University of Technology*
Gdansk, Poland
adabujno@pg.edu.pl

2nd Mariusz Kaczmarek

*Biomedical Engineering Department,
Faculty of Electronics, Telecommunications
and Informatics, Gdansk University of Technology*
Gdansk, Poland
markaczm@pg.edu.pl

3rd Kamil Osinski

*Biomedical Engineering Department,
Faculty of Electronics, Telecommunications
and Informatics, Gdansk University of Technology*
Gdansk, Poland
kamilosinski1@gmail.com

4th Michal Gramowski

*Biomedical Engineering Department,
Faculty of Electronics, Telecommunications
and Informatics, Gdansk University of Technology*
Gdansk, Poland
michal.gramowski@gmail.com

5th Jerzy Wtorek

*Biomedical Engineering Department,
Faculty of Electronics, Telecommunications
and Informatics, Gdansk University of Technology*
Gdansk, Poland
jerzy.wtorek@pg.edu.pl

Abstract—An optoelectronic device enhancing a smart chair functionality is presented in the paper. Its essential purpose is a detection of a sitting person presence on the chair by means of detecting the vital signs. Additionally, it could be used for determining of clothes layer parameters useful in adjusting a system of a capacitive electrocardiography.

Index Terms—smart chair, biosignals, ambient assisted living, infrared PPG sensor

I. INTRODUCTION

Ambient assisted living is a modern trend worldwide giving opportunity to assist and improve quality of live especially for elders.

Constantly emerging progress in healthcare and technology, improving quality of life causes longer lifetime among societies [1], [2]. Additionally significantly reducing birth rate is drastically changing demographic structure among countries. This trend is spreading worldwide giving several challenges not only at government level. Additionally there is a need for automated or semi-automated data processing [3].

It is believed that technology will play important role in future elders care [4], [5]. Improvement of live quality must

be a fact also for elders. Thus not only from psychological and sociological point of view, but also economically best option is to allow independent life for elders in their natural environment.

A huge challenge is to combine independent life with degrading health status of the person. Traditionally a social caregiver institutions are involved in life support. There will be a lack of people to work for such services in near future. It is believed that technology must be involved to allow increase subjects number per social caregiver [6].

Modern medical devices are evolving, gets miniaturized and are more affordable for the people. Some of medical functionalities can be also included in traditional, well known equipment [7], [8]. An example of such devices can be deep arm chair [9], [10]. This is widely used device at home and it also can be used for person monitoring. Using deep arm chair it is possible to detect if person is sitting on it, track it's activity, measure temperature, humidity and moisture in case of urinary problems.

Recently there is huge research effort to monitor cardiac action of the person at home. Typical ECG monitoring utilize electrodes attached to the human skin and a measurement system that is able to amplify and record of such bio-signals. For daily use electrodes are uncomfortable and can cause skin irritations. In addition ECG device must be portable

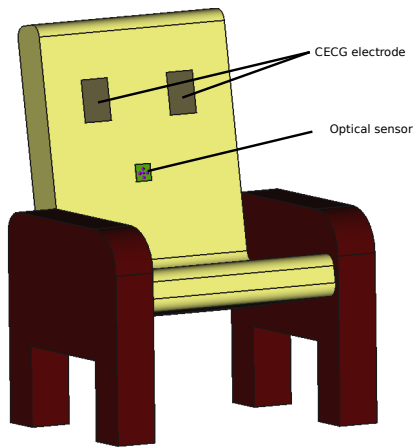

Fig. 1. The CECG chair with infrared sensor location

and battery operated. Another approach is to use the ECG apparatus built in surrounding equipment e.g. chair, bed etc. This limits measurement periods to time where person is using such equipment and involves novel sensing techniques such as capacitance coupled electrodes connected through the clothes. This demands more sophisticated electronics but allow to record ECG-like signals through the clothes while person is sitting on the chair.

The capacitive-coupled electrocardiography (CECG) requires ultra-high impedance probes and high CMRR input amplifier. Such high impedance usually causes unpredictable behavior of the recorded signal when no person is present on the chair. Due to this requirements new detection techniques should provide information about the presence of a person in the chair. There are several techniques to supply information about this fact. For example seat can be equipped with the pressure pillows, weight or capacitive proximity sensor. In the paper we introduce the optical sensor, that can be applied in the back of the chair.

In the paper we investigate application of an opto-electronic sensor giving information about person presence in the chair. In addition, we would extend the use of such a sensor to detect the thickness of the layer of clothing, which has a direct impact on the performance of CECG measurements. The rest of the paper is organized as follows: section "Material and methods" introduces a sensor construction, measurement protocols and data processing. Section "Results" presents achieved findings. Summary of work is presented in section "Discussion" and section "Conclusion" is summarizing the work.

II. MATERIALS AND METHODS

Presence of the person sitting on the chair can be measured by means of reflected optical wave propagation. Thus the sensor can be located in back side of the chair as in Fig. 1. When no person is in the chair there is an ambient light passing the sensor and small amount of the reflected light from LED's reaches the sensor.

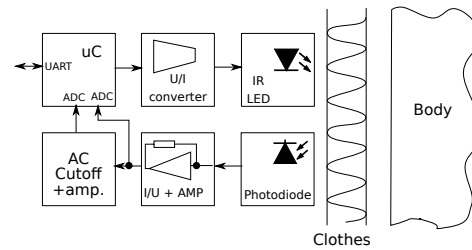

Fig. 2. Block diagram of measurement circuit

In case of artificial ambient light there will be significant AC component of light passing the sensor. This can be additional indication of the unoccupied chair. When the person start approaching the chair AC component (if exists) decreases in amplitude, but additionally wave reflected from the person clothes increases signal response. It is going to increase until sensor is fully covered with person body. Opposite situation occurs when leaving the chair. If the sensor is covered by the body, it is likely that some of the emitted light will be reflected back by the body and clothing to the photo-diode. If light will be transferred through the body and clothes it might be altered by the blood circulation inside body. In addition returning signal will be affected by the clothes.

A. Circuit block diagram

The measurement circuit (Fig. 2) consists of IR LED controlled current source, photo-diode receiving signal and multi-stage amplifier. Reflected IR wave is picked up by the photo-diode and current to voltage converter. Received signal is amplified and it forms first output of the sensor responsible for total light. The small AC component of this signal may contain pulse information. Thus high-pass filter is applied to allow further AC component amplification. After filtration received signal is additionally filtered and amplified to receive the pulse component. This information is passed to the second ADC. Whole process is controlled by the microcontroller equipped with the DAC, ADC and UART.

B. Experiment setup

Device has been designed to support decision of CECG measurement circuit. Detecting the presence of a person in a chair is the main function. An additional feature is to estimate clothes layer thickness that might alter CECG measurements. The experiment was conducted as depicted in Fig. 3. In total, three signals were measured. Signals depicted as 'o1' is the photo-diode total light signal, where 'o2' is the amplified AC component of the 'o1'. Additionally for the reference a finger PPG reflective signal was measured.

In the experiment total amount of 14 people, both male and female were engaged. The age of volunteers was between 22 and 69. Experiment was conducted in two phases. First we asked volunteers to make action sitting on the chair, stay in for approximate 10 seconds and then leave the chair. At this stage we have monitored 'o1' and 'o2' signal simultaneously. For the simplicity and increased resolution we have measured



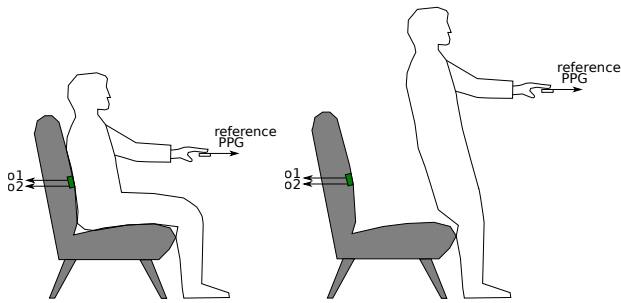

Fig. 3. Experiment conducted

analog components of the signals by means of the Analog Discovery 2 tool [11].

In the second phase of the experiment we measured simultaneously the 'o2' signal with reference PPG one obtained from the reflective PPG sensor attached to the left hand pointing fingertip. The measurement protocol involves steady sitting on the chair with resting on the chair-back. During a series of such measurements, we changed the layer of clothing, placing an additional layer between the measured person (body) and the shoulder support.

C. Signal analysis

The basic purpose of the circuit is to detect, whether person is sitting on the chair or not. It was originally meant to support CECG measurement system when to start or stop the measurements. To achieve this task algorithm constructed on the information described above can be implemented.

For person presence in the chair total light is to be measured. When a person is in the chair, total light should be measured. It is combination of the ambient and infra-red LED's reflected from the body. Sensor construction prevents direct illumination of the photo-diode by IR-LED's.

We can detect light reflected from clothing while a person approaching the sensor. Reflection can be detected from approx 50 cm from the sensor. As the body is getting closer, amount of ambient light is decreased resulting raise of reflected signal. From approx 8cm reflected light is saturating photo-diode. Decrease of reflected signal occurs when the obstacle is 4mm from sensor's front. When the sensor will be touching person's body only IR scattered light will reach the sensor. During all measurement infra-red LED current is controlled and set at constant value. Device itself allows LED's current control, but as for initial experiments it is not utilized. Scattering is caused both by the body and clothes, additionally this light might contain the biomedical signal related to blood circulation and internal organs movement. The estimated signal shape of received light for short experiment while person is sitting and leaving of the chair can be described as in Fig. 4.

A quality of the CECG depends on the clothes worn by sitting person. Too many layers or too thick clothing decreases signal quality and makes impossible to measure.

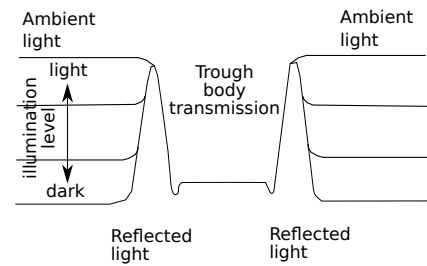

Fig. 4. Person presence detection in different illumination level

As in the phase of sensor fully covered by the body - detected signal contains pulse wave - it is possible to relate number of clothes layers/thickness to the amplitude of received PPG signal.

III. RESULTS

We have designed and manufactured sensor as in schematic in Fig. 5. The circuit was assembled on custom designed PCB as in Fig. 6.

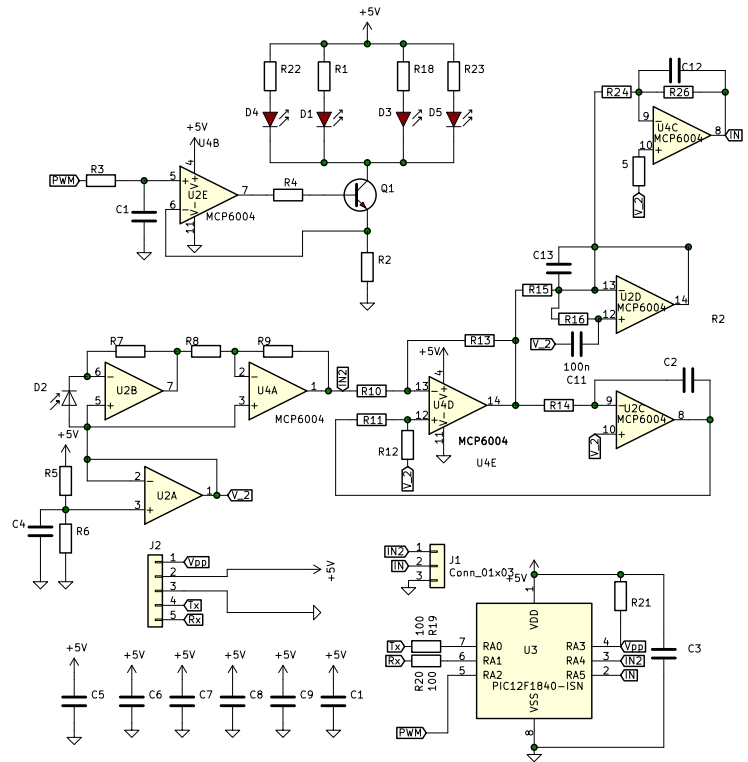

Fig. 5. Schematic diagram of designed sensor

A. Sitting phase detection

In the first phase we have measured the total signal for the whole sitting action. We have asked person to sit, stay in the chair for approx 10 seconds and then leave the chair. An example of record is shown in Fig. 7.

Observation of the 'o1' signal leads to some conclusions. First of all when there is no person in the chair, an ambient



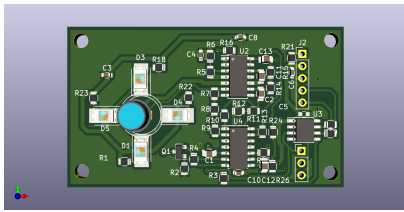

Fig. 6. 3D visualization of the sensor's printed circuit board

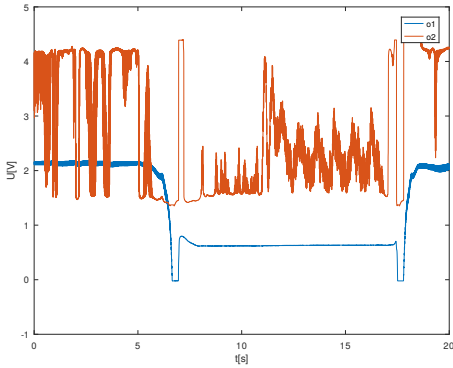

Fig. 7. Output signals out of the sensor while sitting and leaving of the chair. Please note o1 signal is inverted comparing to description in Fig. 4

light is received by the photo-diode. If the chair is located inside room, most probably artificial light is used. In such case there could be a significant component at mains frequency observed by the sensor.

As the person is approaching the sensor - photo-diode is getting covered by the body and total signal is decreasing. When body will cover the sensor completely, a light passing to the photo-diode slightly increase as it will be distracted by the body. If the number of clothes is not too high - on the signal 'o2' an pulse will be visible.

It is obvious, that measured signals will be reversed in time when person will leave the chair.

The person detection algorithm can rely on total light signal information. The procedure can be as described in Fig. 8. For continuous signal we calculate moving average and moving variance with 1s window width.

$$A(n, k) = \frac{\sum_{n-k}^{n+k} o1[n]}{k}$$

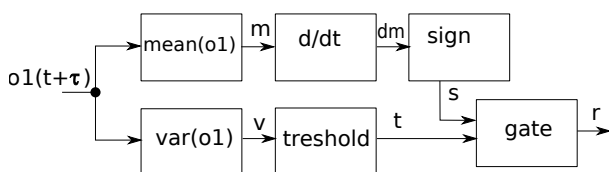

Fig. 8. Person presence algorithm proposition

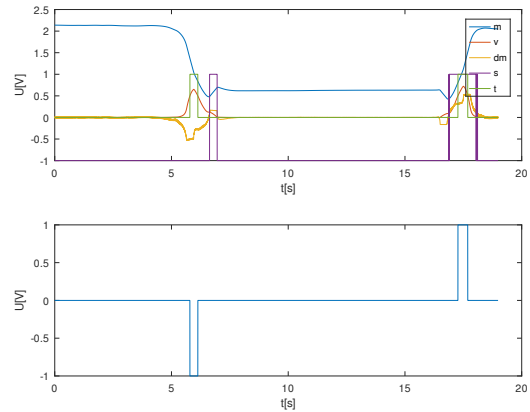

Fig. 9. Detection algorithm exemplary results. Signal names in reference to Fig. 8. Lower chart denotes two clearly distinguished moments (sitting=-1, leaving=+1)

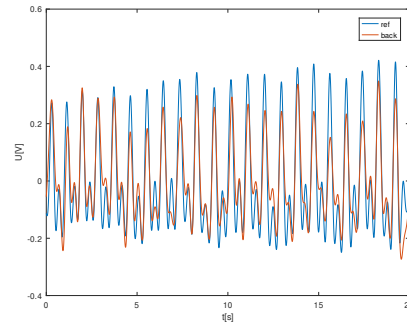

Fig. 10. Raw data obtained from the sensor; ref - reference data from finger sensor; back - data from the back plane sensor

$$V(n, k) = \frac{(\sum_{n-k}^{n+k} x[n] - A(n, k))^2}{k}$$

Then we calculate sign of moving average first order derivative for periods where moving variance is greater than threshold. Results of signal and calculations are shown in Fig. 9. Lower chart is showing detected moments. Negative values are showing movement where person is during sitting period. Positive values denotes chair leaving action.

B. Estimation of the clothes thickness

When a person is sitting in a chair - transmitted infrared light will penetrate the body and thus will be dispersed, but a certain percentage will be reflected on the photodiode. In result a small portion of the light will be received by the photo-diode. Magnitude of the body penetrated light will be altered by the blood circulation according to Lambert-Bier law. This small portion of light will be converted to the voltage and amplified. We can amplify just AC component of the signal and focus on the amplitude and shape of reflected signal. Example of received signal is shown in Fig. 10.

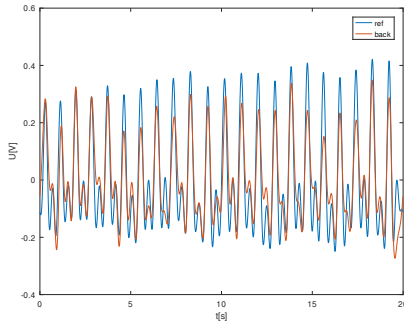

Fig. 11. Filtered data obtained from the sensor; ref - reference data from finger sensor; back - data from the back plane sensor

TABLE I
CLOTHES LAYERS DESCRIPTION FOR SELECTED VOLUNTEER

Clothes Id	Description
1	thin silk blouse (1 layer)
2	(1) + cotton T-shirt (2 layers)
3	(2) + cotton shirt (3 layers)
4	(3) + cotton shirt (4 layers)

Received signal contains both, low- and high-frequency noise components, thus it should be band-pass filtered in order to calculate amplitude resulting from the blood circulation system. We have applied high-order bandpass filter with frequency from 0.5Hz up to 5Hz. Results of filtration is shown in Figure 11.

For each volunteer we have calculated amplitude of received pulse signal. We have correlated this with clothes worn by the volunteer. Example results for single person are shown in Fig. 12. During experiment we keep the IR LED driving current at constant value. The clothes layers are described in Table I.

IV. DISCUSSION AND CONCLUSION

The initial design for the proposed solution was intended for detection of person presence (approaching or leaving) the chair. As sensor started to be developed we have found it useful in estimation of clothes layers number and thickness.

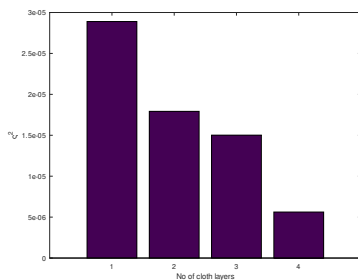

Fig. 12. Variance of the pulse signal vs number of clothes layer - an example for the individual volunteer (layers 1-4 described in Table I)

Determination of clothes thickness relies on amplitude estimation of the pulse signal. Apparently when the system is able to measure pulse - it is possible to calculate heart rate and it's derivatives by using designed solution.

During multiple tests we checked behavior of various clothes fabric. Organic fabrics allows IR light to pass even several layers of clothes. We have used cotton T-shirts and shirts. Unfortunately any addition of artificial fabrics such as elastane causes complete lack of the pulse signal. This feature is to be investigated, as authors already have some thesis, that must be proofed.

During set of experiments with the use of volunteers we tested that sensor works well for people with different gender, age and BMI. By set of experiments we have found optimal location of the sensor. The best position is below ribs over the latissimus dorsi muscle about 3-5 cm left or right to the spine.

Future investigation should involve searching optimal location of the sensor - to achieve best quality signal. Additionally internal organs such as tendon or lungs might affect cardiac signal as well. It is believed that proper sensor location affects resulting signal.

REFERENCES

- [1] Unmilan Kalita. An econometric investigation into variations in life expectancy at birth across countries. *International Journal of Science and Research (IJSR)*, pages 1832–1836, 2019.
- [2] Veena S. Raleigh. Trends in life expectancy in eu and other oecd countries. (108), 2019.
- [3] R. Fernandez Molanes, K. Amarasinghe, J. Rodriguez-Andina, and M. Manic. Deep learning and reconfigurable platforms in the internet of things: Challenges and opportunities in algorithms and hardware. In *IEEE Industrial Electronics Magazine*, volume 12, pages 36–49, June 2018.
- [4] Emad Aghayi and Moein Noferesti. Smart homes for elderly healthcare-ercent advances and research challenges. *Sensors*, 2017.
- [5] Ali Hussein, Mehdi Adda, Mirna Atieh, and Walid Fahs. Smart home design for disabled people based on neural networks. *Procedia Computer Science*, 37:117 – 126, 2014. The 5th International Conference on Emerging Ubiquitous Systems and Pervasive Networks (EUSPN-2014)/ The 4th International Conference on Current and Future Trends of Information and Communication Technologies in Healthcare (ICTH 2014)/ Affiliated Workshops.
- [6] R. Ogawa and T. Togawa. Attempts at monitoring health status in the home. In *1st Annual International IEEE-EMBS Special Topic Conference on Microtechnologies in Medicine and Biology. Proceedings (Cat. No.00EX451)*, pages 552–556, 2000.
- [7] M. Kaczmarek, A. Bujnowski, K. Osiński, and J. Wtorek. A scale with ecg measurements capability for home cardiac monitoring. In *EMBECE 2017, NBC 2017. IFMBE Proceedings*, volume 65, pages 984–987, 2017.
- [8] A. Bujnowski, J. Ruminski, A. Palinski, and J. Wtorek. Enhanced remote control providing medical functionalities. In *2013 7th International Conference on Pervasive Computing Technologies for Healthcare and Workshops*, pages 290–293, May 2013.
- [9] Y. Sun and X. B. Yu. Capacitive biopotential measurement for electrophysiological signal acquisition: A review. *IEEE Sensors Journal*, 16(9):2832–2853, May 2016.
- [10] Antje Pohl, Benjamin Eilebrecht, Tobias Wartzek, Marian Walter, and Steffen Leonhardt. Advances in modern capacitive ecg systems for continuous cardiovascular monitoring. *Acta Polytechnica*, 51:100 – 105, 01 2011.
- [11] Analog discovery product page, <https://analogdiscovery.com/>, access[20-02-2020].