

CARGO SHIPS' HEAT DEMAND - OPERATIONAL EXPERIMENT

Damian Bocheński

Dominik Kreft

Gdańsk University of Technology, Poland

ABSTRACT

The paper presents the results of an experiment conducted on two cargo ships – a 5300 TEU container with a steam heating system and a 7500 dwt general cargo ship with a thermal oil system. On both ships research has been carried out using specially designed measuring equipment. After gathering data about flow velocity and temperatures (steam/ cooling water/ thermal oil/ seawater/ outside air), calculations have been done, resulting in histograms. For both types of histograms (heat demand and service time), the probability density function was fitted, using the K-S statistical test. The last step was comparison of the probability distribution mean to seawater and the outside air temperatures by linear regression and the coefficient of determination. The dependencies between the mentioned temperatures and heat demand were noted.

Keywords: heating system, heat demand, steam, thermal oil

INTRODUCTION

One of the most important installations in marine diesel power plants is the heating system. Its main purpose is to cover the heat demand created by auxiliary receivers, i.e. those not related to the ship's propulsion system. Auxiliary heat receivers can be divided into [4]: steam coils in tanks (mainly fuel tanks), preheaters of fuel oil, lubricating oil, air and water and technological receivers (e.g. in factory-trawlers, fishmeal boilers).

Ship heating installations are most often steam or oil systems. Steam installations are used on three quarters of all cargo ships, where the working medium is saturated dry steam with a pressure from 0.5 to 1.6 MPa (hence the steam temperature is in the range of 152–202°C). The heating oil may be mineral or synthetic, its operating temperature may exceed 300°C and the pressure in the installation is less than that of steam, usually from 0.2 to 0.5 MPa [7,8].

The main devices in the heating system are boilers. There are two types of auxiliary boilers in ships, fired and

economizer, which use the waste heat from the main engine's exhaust gas. The vast majority of cargo ships are equipped with both types of boilers. The exhaust gas economizer cover the heat demand during the voyage, and the fired boilers are used during manoeuvres, anchoring and mooring. On some ships with a high heat demand (e.g. tankers), both types of boiler work simultaneously during the voyage.

Designing marine heating systems consists of several steps. Firstly, during the contract design, the initial heat demand is determined (regression equations are used to estimate the maximum heat demand or the maximum capacity of the ship's boilers [1,3,6,8,9,10]). Based on this, the preliminary parameters of the heating medium and the number, size and type of boilers are selected. Secondly, at the level of the technical (classification) design, the heat balance is prepared. The preparation condition is that all the parameters of the auxiliary heat receivers on the ship have to be known. The heat balance is performed for two extreme external conditions in which the designed vessel will be operated. Winter conditions (usually: $t_{\text{water}} = -1^{\circ}\text{C}$, $t_{\text{air}} = -25^{\circ}\text{C}$) determine the maximum

heat demand, and summer conditions (usually: $t_{\text{water}} = 32^{\circ}\text{C}$, $t_{\text{air}} = 45^{\circ}\text{C}$) determine the minimum heat demand [1,6,10]. The heat balance is the basis for verification of the correct selection of the number and capacity of boilers. After this verification, other components of the heating system are selected (pumps, heat exchangers, fittings, etc.).

As it can be observed, the essential element of the design process is the determination of the heat demand for the designed vessel, as the parameters of all heating system devices depend on it. The methods used in design practice (regression equations, balance methods) allow the maximum (often with excess) heat demand to be determined and the size of the boilers to be selected. There are no existing methods that allow the parameters of the operational heat demand distributions on a ship to be determined. Such methods should be based on gathering operational data on the heat demand in ships, but the available literature does not present the results of any such studies. Most authors focus on heat recovery to improve the ship's general efficiency [12,13,14], but the question of exactly how much heat is needed for the ship's condition is not answered, although sometimes partial heat demand such as the hot water demand on a cruise ship [15], or the ship's thermal storage tank heat demand [16] can be found in publications. Paper [17] presents actual heat demand, but only for one ship and a one-day time period, which is too short to formulate conclusions. For this reason, the authors of this article have planned an experiment to collect operational data on marine heating systems, including operational data on the heat demand in ships. This article presents the first results of these studies.

RESEARCH OBJECTS

The results of the operational heat demand research are presented below. This article concerns two cargo ships, with significantly different sizes:

- Container ship 5300 TEU;
- Cargo ship 7500 dwt.

Table 1. Basic parameters of considered ships

Parameter	Container ship 5300 TEU	Cargo ship 7500 dwt
Length overall L_c	294.05 m	122.50 m
Length between perpendiculars L_{pp}	282.50 m	115.15 m
Beam B	32.30 m	18.20 m
Draft T	13.60 m	7.15 m
Maximum speed v	24.8 (20.6)* kn	15.0 kn
Propulsion engine power N_{SG}	2-stroke 40040 (24024)* kW	2-stroke 4320 kW
Crew members Z	20	15
Heating system	steam	thermal oil
HFO tanks total capacity V_p	5925 m ³	675 m ³
Deadweight tonnage	65700 ton	7500 ton
Average exhaust gas flow	102.8 ton/h	25.6 ton/h
Average exhaust gas temperature after TC	332.1°C	291.8°C

* The vessel was operated with a reduced value of the maximum sailing speed (20.6 kn), therefore the main engine power was calculated according to this speed value

The basic technical data of the considered ships are presented in Table 1. A significant difference between these ships, apart from their size, is the different kinds of heating system. There is a steam installation on the 5300 TEU container ship, which consists of a combined boiler with a fired and exhaust gas part. Each of these parts produces a maximum of 5000 kg/h of steam at a pressure of 7 bar (approximately 3300 kW). In addition, the steam system is equipped with a condensate cooler and dump condenser. Each of these has capacity equal the maximum steam stream from the exhaust gas boiler part. The oil heating system of the 7500 dwt general cargo ship consists of a 750 kW fired boiler and a 600 kW economizer (operating at 90% main engine load).

OPERATIONAL RESEARCH PLAN

The method of determination of the current operational heat demand on board QCE, depends on the design solutions of the heating system. In the case of a steam system, the main equation is:

$$Q_{CE} = D_{\text{steam}} \cdot (i_{\text{steam}} - i_{\text{condensate}}) \quad (1)$$

where:

Q_{CE} – heat flux equal to ship's heat demand, kW

D_{steam} – boiler steam mass flow, kg/h

i_{steam} – steam specific enthalpy at the inlet to the receivers, kJ/kg

$i_{\text{condensate}}$ – condensate specific enthalpy at the outlet from receivers, kJ/kg.

Measurement of the true steam mass flow is problematic, because dedicated flowmeters are not normally installed. The steam mass flow can be determined using one of the following methods [2]:

- by measuring the feed water mass flow and treating it as equal to the steam mass flow. This method neglects errors related to the boiler heat capacity and water losses during boiler skimming;

- by measuring fuel consumption (in the case of a fired boiler) and using appropriate load characteristics.

Determining the steam specific enthalpy at the inlet to the receivers is not a problem, and it is enough to know the steam pressure and the vapour quality. It is much harder with the specific enthalpy of the condensate at the outlet of the receivers. Steam trap check valves are installed after each receiver to prevent the steam flowing into the condensate pipeline. This makes it impossible to accurately determine the enthalpy.

Therefore, in the case of a steam installation, determining the actual operational heat demand is possible only with measurements made on the dump condenser. Determination of the heat exchanged in the condenser Q_{DC} and the heat generated in the boiler Q_B makes it possible to calculate the heat demand:

$$Q_R = Q_B - Q_{DC} \quad (2)$$

The following equation is usually used to determine the heat generated in the boiler:

$$Q_R = D_{steam} \cdot (i_{steam} - i_{water}) \quad (3)$$

where:

i_{water} – specific enthalpy of the boiler feed water, kJ/kg.

In order to determine the specific enthalpy of the boiler feed water, it is enough to know the temperature and water specific heat at the boiler inlet.

The heat exchanged in the dump condenser can be calculated from the following equation:

$$Q_{DC} = V_{CW} \cdot \rho_{CW} \cdot c_{CW} (t_{CW1} - t_{CW2}) \quad (4)$$

where:

V_{CW} – cooling water flow rate, m³/s

ρ_{CW} – average cooling water density in the relevant temperature range, kg/m³

c_{CW} – average cooling water specific heat in the relevant temperature range, kJ/kgK

t_{CW1} – cooling water temperature at the dump condenser inlet, °C

t_{CW2} – cooling water temperature at the dump condenser outlet, °C.

In the case of a thermal oil installation, the most common solution is the serial operation of the fired and exhaust gas boilers. The control system sets a constant oil temperature at the outlet from the boiler. In order to determine the ship's operational heat demand Q_R , the equation below can be used:

$$Q_R = V_{TO} \cdot \rho_{TO} \cdot c_{TO} (t_{TO1} - t_{TO2}) \quad (5)$$

where:

V_{TO} – thermal oil flow rate, m³/s

ρ_{TO} – average thermal oil density in the relevant temperature range, kg/m³

c_{TO} – average thermal oil specific heat in the relevant temperature range, kJ/kgK

t_{TO1} – thermal oil temperature at the boiler outlet, °C

t_{TO2} – thermal oil temperature at the boiler inlet, °C.

As can be observed from the above-mentioned relationships, to determine the ship's operational heat demand Q_R , it is enough to measure the flow rates of the liquid (water / thermal oil), the liquid temperatures at the inlet and outlet from the tested component (boilers / dump condensers), and to know the liquids' parameters (average specific heat and density of water / thermal oil).

The operational measurements on the 7500 dwt general cargo ship were carried out using the measuring equipment installed on board. In the case of operational measurements on the 5300 TEU container ship, an ultrasonic flow meter was used simultaneously with a thermometer (Fig. 1). The measuring device consists of a TUF-2000M flow meter with TM-1 sensors. The temperature of the water was measured with a PT-100 resistance temperature sensor. The measurement data was saved every 5 minutes on the SD card inside the Raspberry PiZero mini-computer, by means of special software. Furthermore, the measurement device was equipped with a DS3231 real-time clock module, which assigns dates and times to specific measurements.

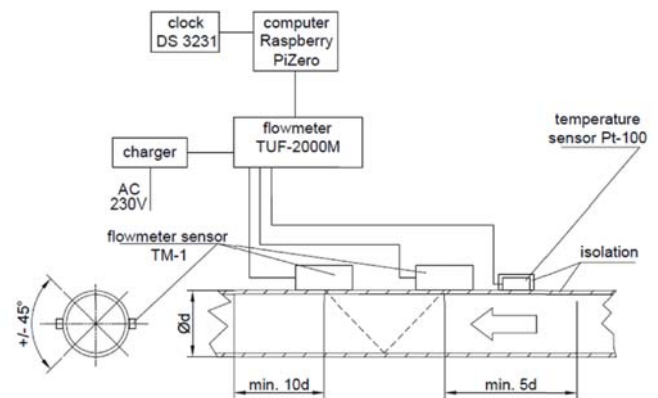

Fig. 1. Diagram of the flowmeter measuring system

Knowing the pipeline's nominal diameter and the wall thickness, the volumetric flow rate was calculated on the basis of the continuity equation. The next step was to use Eq. (3).

ANALYSIS OF SHIPS' HEAT DEMAND MEASUREMENT RESULTS

Determining the ships' operational heat demand characteristics requires the knowledge of changes of this demand over a long period of time. A large number of

instantaneous heat demand values enables a correct statistical evaluation.

The average duration of the “sea (voyage)” state for cargo ships is approximately 4200 hours / year [2]. Due to the limited possibilities of carrying out measurements over such a period of time, operational measurements covering at least one voyage (from harbour to harbour) lasting at least one month were considered. This is approximately 15–20% of the duration of the “sea” state (approximately 700–750 hours). The vast majority of operational tests were carried out in 24-hour cycles.

On the 7500 dwt general cargo ship, measurements of the oil temperature at the inlet and outlet of the boiler and the oil flow rate were usually performed every hour. Additionally, the air and seawater temperatures were recorded every 12 hours.

On the 5300 TEU container ship, measurements of the boiler feed water temperature and flow rate were carried out every 5 minutes. As in the general cargo ship, the air and seawater temperatures were recorded.

From the research conducted it was possible to determine the heat demand distribution characteristics during the “sea” state, including:

Q_{CE}^{sr} – average heat demand,

σ_{CE} – standard deviation of heat demand distribution,

$V_{CE} = \frac{\sigma_{CE}}{Q_{CE}^{sr}}$ – heat demand distribution coefficient of variability.

For calculation of the above values, the average daily heat demand was used, based on measurements taken every 5 minutes or every hour, depending on the vessel.

Table 2 presents data characterising the heat demand distributions. In addition, the maximum values of heat demand Q_{CE}^{max} for winter external conditions (from heat

balances) and the calculated values of the relative average heat demand \bar{Q}_{CE}^{sr} ($\bar{Q}_{CE}^{sr} = \frac{Q_{CE}^{sr}}{Q_{CE}^{max}}$) are presented.

Table 2. Characteristics of heat demand distributions in the two tested ships

Ship	Q_{CE}^{max}	Q_{CE}^{sr}	\bar{Q}_{CE}^{sr}	σ_{CE}	V_{CE}	m
	kW	kW	-	kW	-	
Container ship 5300 TEU	2970	1019.4	0.343	290.3	0.285	93
Cargo ship 7500 dwt	512	227.1	0.443	101.1	0.445	87
average			0.393		0.365	

Comparing the parameters of the heat demand distributions in both ships, it can be noticed that the 5300 TEU container ship has a heat demand that is over 4 times higher than the average value. This is a result of the almost 5 times higher average operational power of the main engine (N_{SG}^{sr}) of this vessel compared to the engine of the 7500 dwt general cargo ship ($N_{SG}^{sr} = 15564$ kW for the 5300 TEU container ship and $N_{SG}^{sr} = 2903.8$ kW for the 7500 dwt general cargo ship). As the main engine’s installed power increases, the capacity of the fuel storage tanks also increases. The value of the coefficient

of variation for the V_{CE} 5300 TEU container ship is 0.285, which is more than 30% lower than the value of the same coefficient for the 7500 dwt general cargo ship. This feature may be due to the fact that the container ship was used only in summer conditions, while the 7500 dwt general cargo ship was operated in both summer and winter conditions.

Fig. 2 shows the ships’ operational heat demand histograms. The individual numerical values of instantaneous heat demand were grouped in left-open quantisation intervals of the same width. The width of the quantisation interval resulted from the division of the range defined by the minimum and maximum operational heat demand. Due to the accuracy of the calculations, 11 quantisation intervals were assumed [2]. According to [5], the histograms were presented with the normal distribution density curves, one of the most frequently used distributions to approximate the distribution of various parameters characterising the ships’ components operation [2,4].

a)

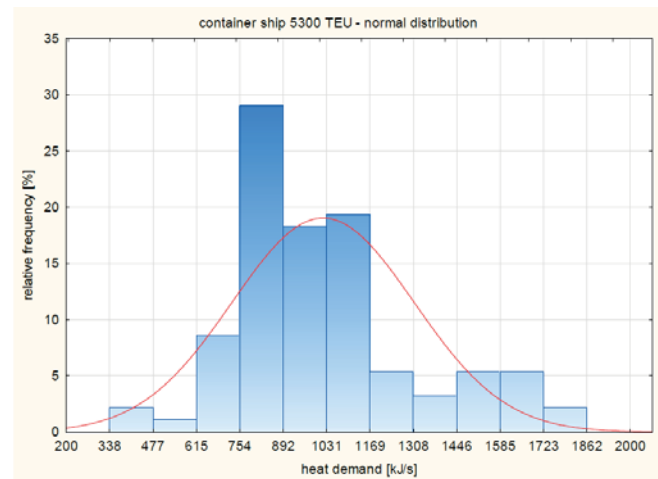

b)

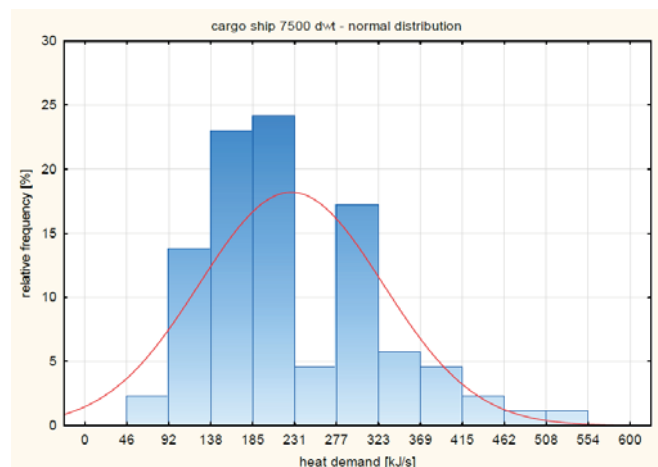
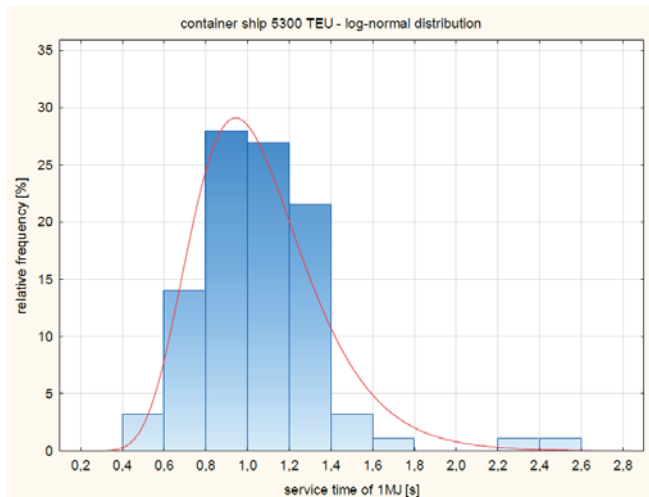

Fig. 2. Histograms of ships’ heat demand: a) container ship 5300 TEU, b) cargo ship 7500 dwt

The second possibility for describing the heat demand is to present the process of covering the heat demand as a process of handling incoming requests. The heating system is treated as a queueing theory process, and the heat dose, e.g. 1 MJ, is considered as the customer [5]. Fig. 3 shows the histograms of the service times (1 customer = 1 MJ). These histograms are presented with the log-normal probability density functions, which best describe the reality for the tested ships [5].

In order to check whether the histograms presented above can be described by an appropriate theoretical distribution, the null hypothesis H_0 was formulated: “The cumulative heat demand histogram can be described by the normal probability density function”. The second null hypothesis H_0' is that “the cumulative service time histogram can be described by the log-normal probability density function”. Both hypotheses were tested using the Kolmogorov–Smirnov test (Tables 3 and 4).

a)



b)

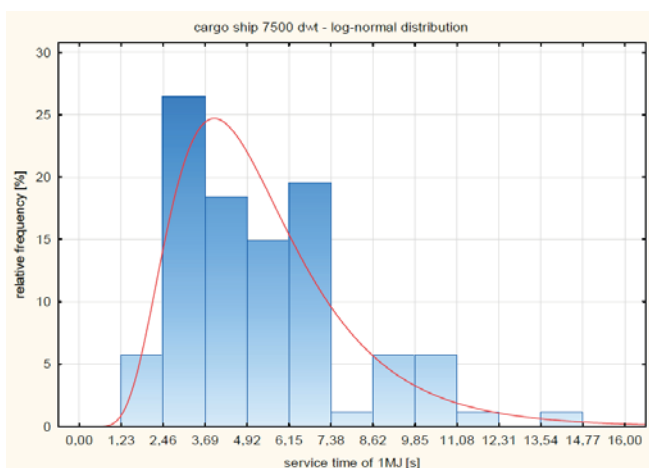

Fig. 3. Histograms of ships' service time for 1 MJ: a) container ship 5300 TEU, b) cargo ship 7500 dwt

Table 3. The values of the Kolmogorov–Smirnov test and the parameters of the probability density curve for the ships' heat demand

Ship type	Calculated value of K-S test	Critical value of K-S test	Statistical significance	Probability density function	Q_{CE}^{sr} [kW]	σ_{CE} [kW]
Container ship 5300 TEU	0.111	0.127	0.1	normal	1019.4	290.3
Cargo ship 7500 dwt	0.010	0.131	0.1	normal	227	101.1

Table 4. The values of the Kolmogorov–Smirnov test and the parameters of the probability density curve for the ships' service time (for 1MJ)

Ship type	Calculated value of K-S test	Critical value of K-S test	Statistical significance	Probability density function	Shape parameter [s/MJ]	Scale parameter [s/MJ]
Container ship 5300 TEU	0.064	0.127	0.1	Log-normal	0.0194	0.280
Cargo ship 7500 dwt	0.024	0.131	0.1	Log-normal	1.581	0.453

For the levels of significance given in Table 3, the value of the p-statistic is less than the critical value, so the alternative hypothesis H_1 “the cumulative heat demand histogram cannot be described in terms of the normal probability density function” has been rejected. Similarly, for the levels of significance in Table 4, the p-statistic value is less than the critical value, so the alternative hypothesis H_1' “the cumulative service time histogram cannot be described by the log-normal probability density function” was rejected. In summary, the heat demand can be described with a normal distribution, and the service time (1 MJ of heat) can be described with a log-normal distribution.

For some heat receivers (e.g. fuel hull tanks), the strong influence of the seawater and outside air temperatures on the heat demand is known [2,8,9]. Therefore, the impact of the above-mentioned temperatures on the total heat demand was tested. For this purpose, the average daily heat demand and average temperatures of the seawater and outside air were calculated for each day. Fig. 4 shows the relation $Q_{CE} = f(t_{water})$, and Fig. 5 shows the relation $Q_{CE} = f(t_{air})$ for the tested ships. The graphs also show the line equation and value of the coefficient of determination R^2 .

a)

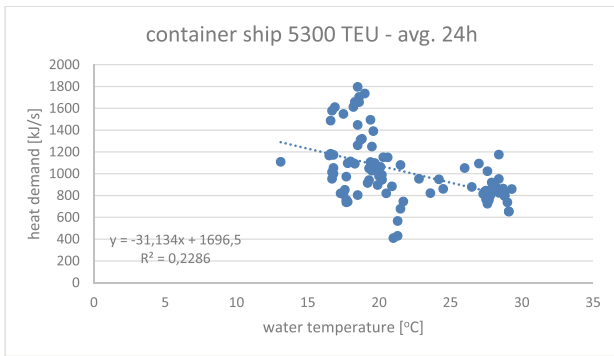

b)

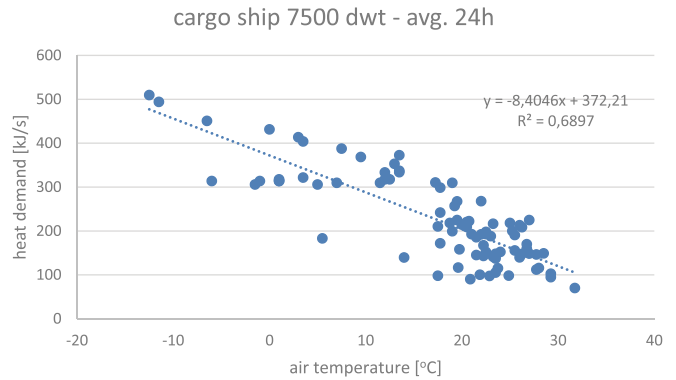

b)

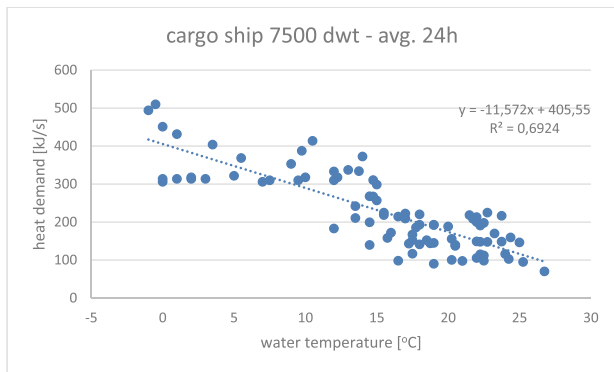
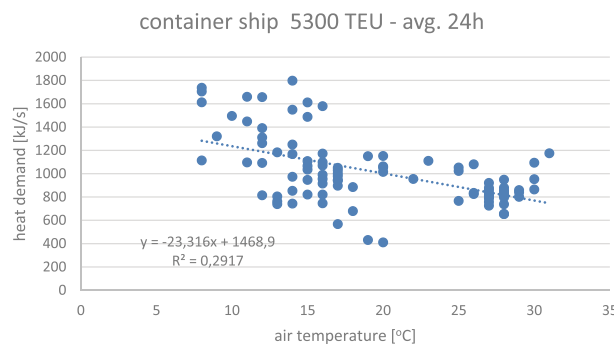

Fig. 5. Chart $Q_{CE} = f(t_{air})$ for ships; a) container ship 5300 TEU, b) cargo ship 7500 dwt

Fig. 4. Chart $Q_{CE} = f(t_{water})$ for ships; a) container ship 5300 TEU, b) cargo ship 7500 dwt

a)



The analysis of the charts (Figs. 4 and 5) shows the significant impact of the seawater and outside air temperatures on the ships' heat demand. The fairly low coefficient of determination R^2 is the result of randomly run heaters (e.g. sanitary water) and the fact that the HFO hull tanks are filled to different levels. For example, in the case of the 7500 dwt ship, the amount of fuel stored in the hull storage tanks was in the range of 50–675 m³. The differences in the values of the coefficient of determination for the 5300 TEU container ship ($R^2 = 0.229$ – 0.292) and for the 7500 dwt general cargo ship ($R^2 = 0.689$ – 0.692) mainly result from the range of water and outside air temperatures ($t_{water} = 13$ – 30 °C for the 5300 TEU container ship, $t_{water} = -2$ – 27 °C for the 7500 dwt general cargo ship and $t_{air} = 8$ – 32 °C for the 5300 TEU container ship, $t_{air} = -13$ – 32 °C for the 7500 dwt general cargo ship). If we delete all data beside the range of $t_{water} = 13$ – 30 °C and $t_{air} = 8$ – 32 °C, the coefficient of determination for the 7500 dwt general cargo ship would take values in the range of 0.296–0.369.

SUMMARY

All the results of the calculations given in this paper concerning the cargo ships' heat demand characteristics and the histograms of these demands reflect the operational reality related to the ships' heat demand (consumption).

The main engine power and the capacity of heavy fuel oil storage tanks have the greatest impact on the value of the total heat demand in cargo ships.

The obtained operational data also confirm the significant influence of the seawater and outside air temperatures on the value of the ships' total heat demand. The considerable variability of the demand results from the different degree of filling of the fuel tanks and from randomly run heaters.

Using the Kolmogorov–Smirnov statistical test, the possibility of describing the heat demand histograms with a

normal distribution and the service time (1 MJ of heat) with a log-normal distribution was confirmed.

The presented results, which will be supplemented further, will be used to develop a method for forecasting the parameters of the operational distribution of heat demand on cargo ships. This method will be part of the new design process. The proposed methods, using probabilistic models, will be tools for analysing various marine heating systems solutions. They will make it possible to determine the operational consequences associated with these solutions.

REFERENCES

1. A. Balcerski, *Marine power plants. Basics of thermodynamics, engines and main drives, auxiliary devices and systems* (in Polish), 2007.
2. A. Balcerski, *Probabilistic models in the theory of marine diesel power plants design and operation* (in Polish), 2007.
3. D. Bocheński, "Method for determining the heat demand on self-propelled dredgers" (in Polish), *XXXI Sympozjum Siłowni Okrętowych*, 2010.
4. D. Bocheński, *The preliminary designing of power plants on dredgers with the use of probabilistic models* (in Polish), 2013.
5. D. Bocheński and D. Kreft, "Possibilities of using probabilistic methods and models in the design of ship heating steam installations (in Polish)," *Journal of Polish CIMEEAC*, 2019.
6. D. Kreft, "Analysis of methods used in the design of marine heating installations (in Polish)," *Journal of Polish CIMEEAC*, 2018.
7. D. Kreft, "Comparative analysis of design layouts for marine heating systems (in Polish)," *Journal of Polish CIMEEAC*, 2018.
8. R. Michalski, *Marine power plants. Preliminary calculations and general rules for the selection of mechanisms and auxiliary devices* (in Polish), 1997.
9. P. Urbański, *Ships energy management* (in Polish), 1978.
10. D. Watson, *Practical ship design*, 1998.
11. H. K. Woud, and D. Stapersma, *Design of propulsion and electric power generation systems*, 2002.
12. M. Grljusic, V. Medica, and N. Racic, "Thermodynamic analysis of a ship power plant operating with waste heat recovery through combined heat and power production," *Energies*, 2014. doi:10.3390/en7117368
13. T. Cao, H. Lee, Y. Hwang, R. Radermacher, and H. Chun, "Modeling of waste heat powered energy system for container ships," *Energy*, 2016. doi: j.energy.2016.03.072
14. K. Senary, A. Tawfik, E. Hegazy, A. Ali, "Development of a waste heat recovery system onboard LNG carrier to meet IMO regulations," *Alexandria Engineering Journal*, 2016. doi: j.aej.2016.07.027
15. M. Manzan et al., "Potential of thermal storage for hot potable water distribution in cruise ships," in *73rd Conference of the Italian Thermal Machines Engineering Association ATI 2018*.
16. F. Baldi, C. Gabriellii, F. Melino, M. Bianchi, "A preliminary study on the application of thermal storage to merchant ships," in: *7th International Conference on Applied Energy – ICAE2015*.
17. Y. Yan et al., "Multi-objective design optimization of combined cooling, heating and power system for cruise ship application," *Journal of Cleaner Production*, 2019.

CONTACT WITH THE AUTHORS

Damian Bocheński

e-mail: daboch@pg.edu.pl

Dominik Kreft

e-mail: domkref@pg.edu.pl

Gdańsk University of Technology
Narutowicza 11/12
80-233 Gdańsk
POLAND

