

AN INNOVATIVE METHOD OF MEASURING THE EXTENSION OF THE PISTON ROD IN HYDRAULIC CYLINDERS, ESPECIALLY LARGE ONES USED IN THE SHIPBUILDING AND OFFSHORE INDUSTRY

Paweł Dymarski* 

Gdansk University of Technology, Institute of Naval Architecture and Ocean Engineering, Poland

Czesław Dymarski 

Gdansk University of Technology, Institute of Naval Architecture and Ocean Engineering, Poland,

Piotr Grymajło

Poland

* Corresponding author: pawdymar@pg.edu.pl (Paweł Dymarski)

ABSTRACT

The article presents the results of selected works related to the wider subject of research conducted at the Faculty of Mechanical Engineering and Shipbuilding at the Gdańsk University of Technology, regarding designing various on board devices with hydraulic drive for ships and other offshore facilities. One of the commonly used these mechanisms are hydraulic actuators with the measurement of the piston rod extension. The issue of precise measurement of the piston rod extension is extremely important in modern technologies of construction, assembly and precise displacement and positioning of large and heavy, both land and ocean engineering objects or structural elements with the use of several large hydraulic cylinders working in parallel. The article presents a one of two new patented P.425099 – A device for measuring the extension of a hydraulic cylinder piston rod. [1].

Keywords: hydraulic cylinders, piston rod extension measurement, roller rotation sensor

INTRODUCTION

The issue of precise measurement of the extension of a hydraulic cylinder piston rod is very important in the contemporary dynamic development of new machines and devices, especially automatic machines with hydraulic drive, requiring precise control of the process of their operation and protection against overload [2]. In the technical literature and on websites [3,4,5,6,7] you can find information with a general description of the principle of operation and the main technical and geometric parameters of this type of actuator, but usually without precise description of the piston rod extension measurement. Meanwhile, the development of

increasingly larger structures and devices, not only on land, but also on the sea, both installed and floating during the construction, assembly and operation of which, it is required to precisely move large and heavy elements with the help of several parallel actuators. An example of the need to use such actuators are various types of equipment for ships and platforms, including, for example, mechanisms for changing the reach of deck cranes, mechanisms for opening and closing and holding in a set position external and internal ramps and watertight doors, mechanisms for opening and closing various types of hatch covers, systems compensation of flooding of specialized equipment for offshore drilling and exploitation of deposits from floating objects, as well as ship equipment

for servicing offshore wind farms. In particular, devices for automatic piston extension measurement can be used during the installation process of floating wind turbines [8,9,10,11].

When using sliding motion machines in ocean engineering, an important issue is to solve the problem of proper sealing. The paper [12] presents an innovative solution of sealing with the use of magnetic fluid seals for reciprocating motion. On the other hand, the influence of water and mineral oil on mechanical losses in a hydraulic motor for offshore and marine applications is presented in [13].

The need for high precision during the above-described applications resulted in the development and creation of several methods of measuring the extension of the actuator piston rod and their application in practice. The results of their operation so far have allowed their producers to assess to some extent a number of important features of their operation, including mainly the method and precision of measurement, reliability, purchase and operation costs. Several of the most popular methods are presented and characterized in [3]. The solutions presented there usually use magnetostrictive sensors. A description of the basics of the measurement method is provided in [14]. They mainly differ in the location of the magnetostrictive sensor. When deciding on the measurement at the actuator design stage, the sensor can be integrated into the cylinder itself, but if the actuator already exists, the sensor is placed outside the cylinder, and the displacement measurement can be performed using draw wire sensors and magnetic or optical measuring rods or measuring tapes. A significant problem here was the design of the sensor and the routing of the signal outwards, as the cylinder housing bore is always a weak point as there is a high risk of oil leakage at higher operating pressures [15]. The above-mentioned measurement methods are characterized by considerable construction complexity, difficult access to sensors operating in variable pressure conditions and a high cost of execution and operation.



Fig. 1. Photo of the actuator with a magnetostrictive sensor located at the bottom of the cylinder

For a better visualization of the subject matter of the invention, Fig. 2 shows a drawing of an actuator without measuring device and with a relatively very large diameter of the piston rod in relation to the diameter of the cylinder ($d_r/D_c = 0,82$), which is usually used for difficult sea and land operations requiring precise movement of large, heavy

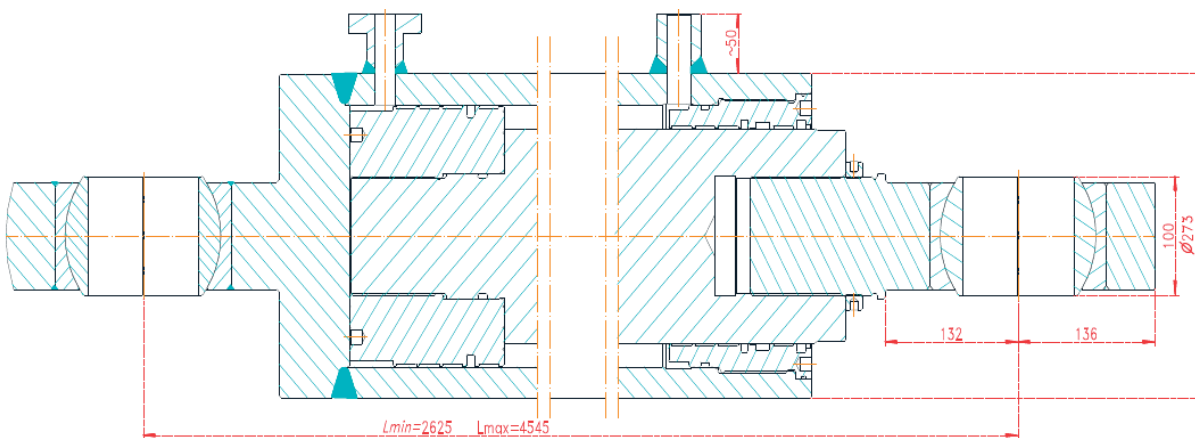

Fig. 2. Longitudinal cross-section a typical hydraulic cylinder, without a sensor for measuring the extension of the piston rod, which up to now often are used to move large and heavy elements with the help of several similar parallel mounted actuators.

objects by means of a set of several parallel working hydraulic cylinders. In these cylinders, the available space between the cylinder tube and the piston rod is smaller, which makes it difficult, but as shown in Fig. 3 and in Fig. 4, does not prevent the application of the method according to the invention shown when installed in such a cylinder. Magnetostrictive sensors are also widely used in robotics. Zhang et al describe the use of magnetostrictive tactile sensor array in robotic fingers [16]. The use of magnetostrictive sensors for precise botanical measurements is presented in [17]. Descriptions of Magnetostrictive Control Rod Position Identification applications are also presented in [18,19].

Another method of measuring the extension of the piston rod - using microwaves, developed by Dorneich and Fritton, was presented in the article [20]

AN EXAMPLE OF USING THE NEW MEASUREMENT METHOD

The method of measuring the actuator piston rod displacement, shown in Fig. 3, according to the invention, is characterized in that the measuring unit is placed in a closed pressureless chamber located in the cylinder body 1, but outside the working chambers, behind a partition 2 with elements guiding and sealing the piston rod 3. This cylindrical chamber is closed with a disc-shaped cover 4 screwed to the said partition 2. In the axis of the cover there is a cylindrical opening with a circumferential channel in which an elastic scraper 5 and sealing ring is mounted [21]. The diameter of this hole is slightly larger than the diameter of the piston rod, which allows it to move freely in relation to the cover while maintaining the tightness of the chamber with the measuring assembly. A body 8 with elements of

the measuring device is attached to the inner face of the cover 4 with screws or welded on. The body 8 has two arms, one larger and thicker, with a cylindrical opening. The axis of this hole is in a plane perpendicular to the axis of the cylinder. The hole houses an axle 9 with two cylindrical pivots of different diameters and a threaded end with a transverse slot for a screwdriver. This axle is mounted with a smaller pin in the body 8 arm and rigidly fixed to it with nuts 10. Two rolling bearings 12 are mounted on the journal with the larger diameter of this axle, with intervals determined by the length of the spacer sleeves 11. These bearings support a roller 13 made of a magnetic material, e.g. polyamide, and on the outer cylindrical surface it is advantageous to apply a layer 15 (sleeve) made of a more flexible material, e.g. rubber or other material with appropriate properties [7]. The geometrical parameters of the axles and the roller as well as their positions are selected in such a way that the roller with its cylindrical surface slightly presses the piston rod 3, so that the linear movement of the piston rod 3 in the cylinder causes the roller to rotate. A shallow, cylindrical recess in which a permanent magnet 16 is mounted is made on the front surface of the roller 13 along its axis of rotation. Opposite the face of the roller with the magnet 16, a printed plate 17 is attached to the second arm of the body 8, which is a very precise sensor of the angle of rotation of the magnetic poles rotating together with the roller of the magnet. During the operation of the actuator, the linear displacement of the piston rod will cause the rotating roller with the magnet to rotate along it, and thus generate signals in the printed board, which through the wires 18 connected to it reach the hermetic electrical connector 19 located in the cover 4 wall and through this connector are led to the computer or via an external cable to other control device.

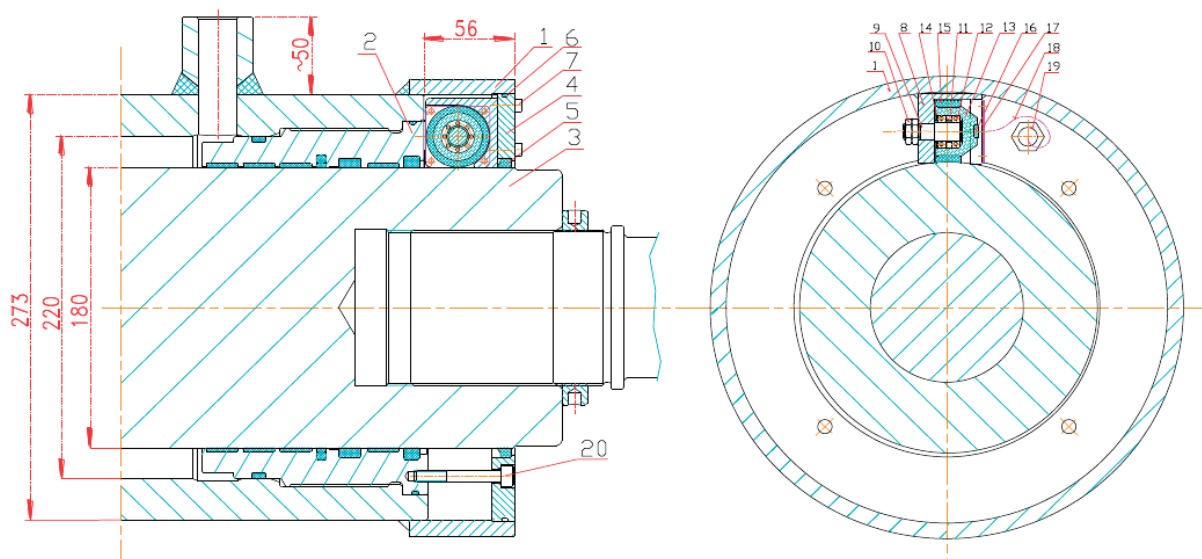

Fig. 3. longitudinal and cross section through the actuator showing the location of the gauge

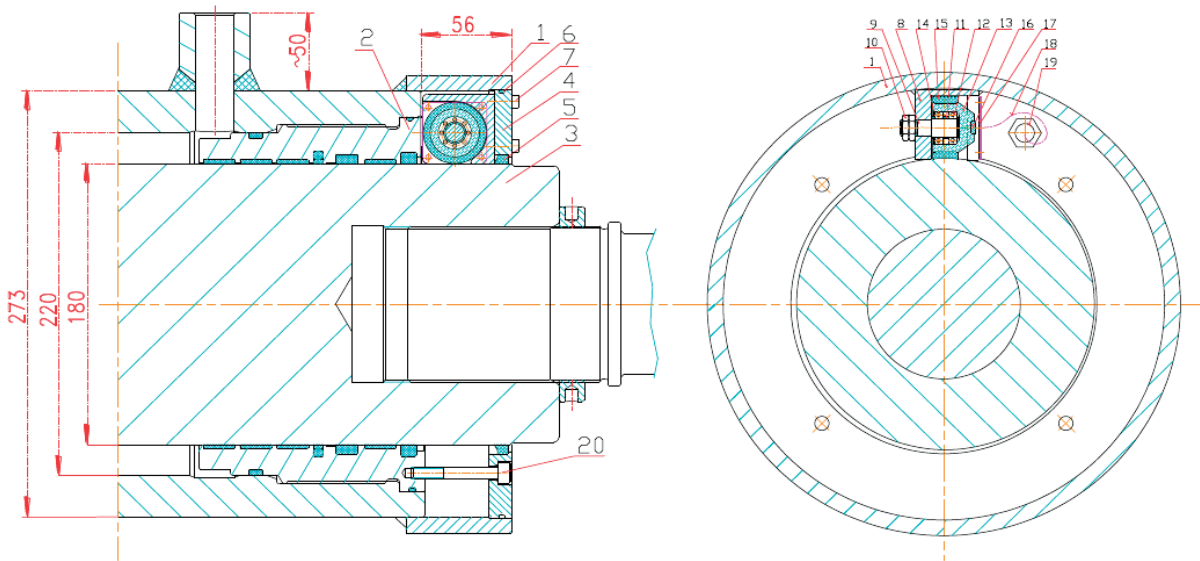

Fig. 3. Longitudinal and cross section through the actuator showing the location of the gauge

A preferred variant is to make an axle 9 with an eccentric pin for bearings with an eccentricity (values of the shift of the axis of this pin in relation to the pin mounting it in the body arm) equal, for example, to $e = 0.5$ mm. Such a solution allows in a very simple way, by changing the angular position of the axle 9 with the roller 13 in the body 8 arm, to precisely regulate the rolling radius within 1 mm and the value of pressure of the roller against the piston rod. This can be done by loosening the nuts 10 on the axle 9, and then turning the axle with a screwdriver to a certain angle and tightening the nuts again, thus locking the changed angular position of the axle. After such adjustment, it is only necessary to enter a new value of the roller radius into the computer program and check the accuracy of indications by fully extending and retracting the piston rod with a known displacement value.

The method according to the invention has several very significant advantages over the methods used so far, namely:

- enables continuous and very precise measurement of the length, direction and speed of the actuator's piston rod extension;
- it is structurally simple and therefore relatively reliable and cheap;
- the measuring unit is placed in a closed chamber, in which there are stable and relatively favorable working conditions, practically independent of very variable, especially in terms of pressure, conditions in the working chambers of the actuator, which is very important, especially for ensuring correct and long-term operation sensors;
- easy access to the measuring assembly without the need to disconnect the hydraulic actuator, requiring

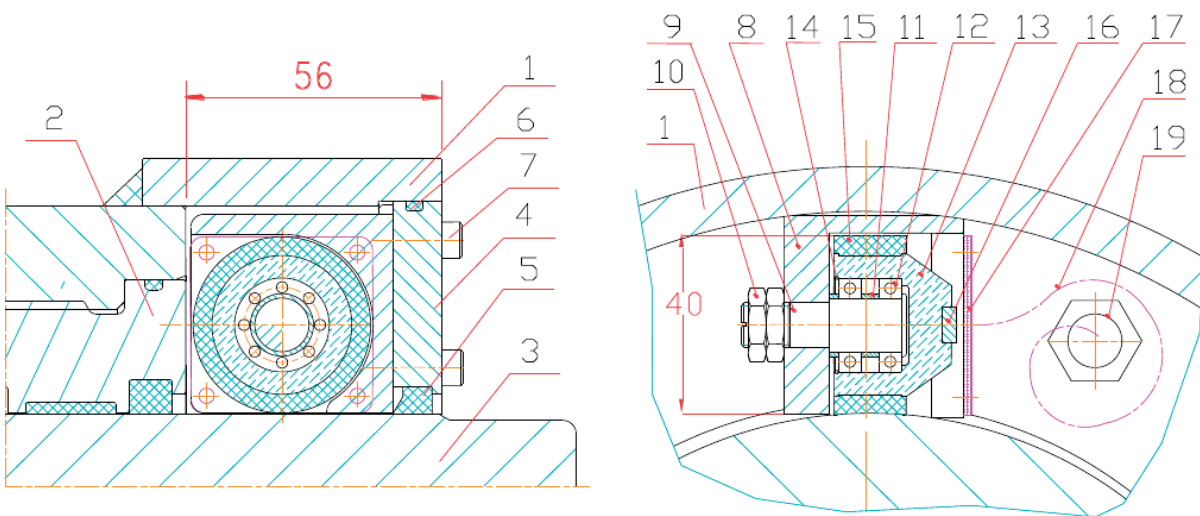

Fig. 4. A device for measuring the extension of the piston rod

only unscrewing the bolts 20 securing the cover 4 and extending the partial piston rod with the cover until the measuring assembly mounted on the inner wall of the cover is fully accessible, which greatly facilitates the control and adjustment of the assembly, and also possible replacement of its elements;

- in the variant with an eccentric axis, a simple and easy way to adjust the pressure of the roller against the piston rod and to introduce corrections to the measurement program, which will significantly extend the life of the roller even in the event of certain changes in the properties of the material from which it is made without the need to replace it with a new one.

Installing the inventive piston rod extension measurement assembly in this exemplary atypical cylinder required only a slight lengthening of the cylinder by welding ~ 60mm of the pipe section 1, and making the cover 4 and the sealing ring 6, which consequently increased the length of the cylinder by 56mm. Compared to the maximum length of this actuator, which is 4545 mm, this represents 1.2%.

SUMMARY

The method of measuring the extension of the actuator piston rod and the designed measuring unit presented in the article are original and patent pending. The authors of the article have not found such a solution in the available publications so far. The presented method of measuring the actuator piston rod extension is, according to the authors, relatively simple and accurate, it enables the device to operate in difficult conditions, without the risk of oil leakage. It allows easy access to measuring instruments and possible replacement of its components without the need to open the working space of the hydraulic cylinder. In order to confirm the above-mentioned advantages of this method, laboratory tests of the actuator were carried out with the presented measuring unit installed. The description of the Laboratory stand and the results of the tests carried out will be presented in the next article.

ACKNOWLEDGEMENT

The authors of the article would like to thank P.H.S Hydrotor S.A. for providing the actuator and construction of the test stand, as well as for the construction of a hydraulic power supply unit. The authors would also like to thank FESCH Feedback Engineering s.c. for the performance of laboratory tests of the measurement system prototype.

The project was financed from the regional programme for founding R&D services “μGrants R&D for enterprises” implemented by Excento Sp. z o.o. (special purpose vehicle of the Gdańsk University of Technology)

BIBLIOGRAPHY

1. P.425099, “A device for measuring the extension of a hydraulic cylinder piston rod “. Patent granted in 2021.
2. “Innovative Ship Relies on Smart Cylinders”, Power&Motion, Feb 1, 2003, <https://www.powermotiontech.com/sensors-software/controls-instrumentation/article/21883570/innovative-ship-relies-on-smart-cylinders>
3. P. Boughton, “Measuring the displacement of hydraulic cylinders”, Design Engineer – Instrumentation, 5th February 2013
4. <https://www.cpi-nj.com/hydraulic-cylinder-position-sensors/>
5. <https://www.cpi-nj.com/linear-position-sensors/>
6. EP1620702B1 patent, “Piston rod position detection system”
7. T. Vanthuyne, “An electrical thrust vector control system for the VEGA launcher”, Proceedings of 13th European space mechanisms and tribology symposium ESMATS’2009, Vienna, 23–25 September 2009 (ESA SP-670, July 2009).
8. Dymarski, C., Dymarski, P., & Żywicki, J. (2017). Technology Concept of TLP Platform Towing and Installation in Waters with Depth of 60 m. Polish Maritime Research, 24(s1), 59-66. <https://doi.org/10.1515/pomr-2017-0022>
9. Dymarski, P., Dymarski, C., & Ciba, E. (2019). Stability Analysis of the Floating Offshore Wind Turbine Support Structure of Cell Spar Type During its Installation. Polish Maritime Research, 26, 109-116. <https://doi.org/10.2478/pomr-2019-0072>
10. Ciba, E. (2021). Heave Motion Of A Vertical Cylinder With Heave Plates. Polish Maritime Research, 28, 42-47. <https://doi.org/10.2478/pomr-2021-0004>
11. Ciba, E., Dymarski, P., & Grygorowicz, M. (2022). Heave Plates with Holes for Floating Offshore Wind Turbines. Polish Maritime Research, 29, 26-33. <https://doi.org/10.2478/pomr-2022-0003>
12. Matuszewski, L. (2019). New Designs of Centrifugal Magnetic Fluid Seals for Rotating Shafts in Marine Technology. Polish Maritime Research, 26(2). <https://doi.org/10.2478/pomr-2019-0023>
13. Sliwiński, P. (2020). The Influence of Water and Mineral Oil on Mechanical Losses in a Hydraulic Motor for Offshore and Marine Applications. Polish Maritime Research, 27(2). <https://doi.org/10.2478/pomr-2020-0034>

14. E. Hristoforoua, A. Ktenab, „Magnetostriction and magnetostrictive materials for sensing applications”, *Journal of Magnetism and Magnetic Materials* 316 (2007) 372–378
15. “Linear displacement transducer isn’t limited by stroke”. *Power&Motion*, March 6, 2013, <https://www.powermotiontech.com/sensors-software/controls-instrumentation/article/21883571/linear-displacement-transducer-isnt-limited-by-stroke>
16. B. Zhang, B. Wang, Y. Li, W. Huang, Y. Li, “Magnetostrictive Tactile Sensor Array for Object Recognition”, *IEEE Transactions on Magnetics*, vol. 55, no. 7, July 2019
17. J.J. Beato-López, I. Royo-Silvestre, C. Gómez-Polo, “Micrometric non-contact position magnetoimpedance sensor”, *Journal of Magnetism and Magnetic Materials* 465 (2018) 489–494
18. Y.W. Park, H.W. Song, E.J. Yoo and J.W. Kim, “Concept and Numerical Verification of Magnetostrictive Control Rod Position Identification,” *The Korean Society of Mechanical Engineers Autumn Conference*, pp. 3672-3673, 2013.
19. E.J. Yoo, Y.W. Park, and M.D. Noh, “Characterization of Detection Signal for Sensing Coil Type in Magnetostrictive Control Rod Position Indicator,” *Proc. of KSPE Spring Conference*, pp. 219-219, 2016.
20. A. Dorneich, M. Fritton, “Microwave Position Sensor for Hydraulic Drives”, *30th Eurosensors Conference, EUROSENSORS 2016, Procedia Engineering* 168 (2016), pp. 1257–1260
21. A.S. Rana, R.S. Sayles, “An experimental study on the friction behaviour of aircraft hydraulic actuator elastomeric reciprocating seal”, *Tribol. Interface Eng. Ser.* 2005;48:507–515. doi: 10.1016/S0167-8922(05)80052-5.

CONTACT WITH THE AUTHORS

Paweł Dymarski

e-mail: pawdymar@pg.edu.pl

Gdansk University of Technology,
Institute of Naval Architecture
and Ocean Engineering, Gdansk
POLAND

Czesław Dymarski

Gdansk University of Technology,
Institute of Naval Architecture
and Ocean Engineering, Gdansk,
POLAND

