

Review

# Review of Methods for Diagnosing the Degradation Process in Power Units Cooperating with Renewable Energy Sources Using Artificial Intelligence

Paweł Ziółkowski <sup>1,\*</sup>, Marta Drosińska-Komor <sup>1</sup>, Jerzy Głuch <sup>1</sup> and Łukasz Breńkacz <sup>2</sup>

<sup>1</sup> Faculty of Mechanical Engineering and Ship Technology, Gdańsk University of Technology, 80-233 Gdansk, Poland; marta.drosinska@pg.edu.pl (M.D.-K.); jerzy.gluch@pg.edu.pl (J.G.)

<sup>2</sup> Department of Turbine Dynamics and Diagnostics, Institute of Fluid Flow Machinery, Polish Academy of Sciences, 80-231 Gdansk, Poland; lukasz.brenkacz@imp.gda.pl

\* Correspondence: pawel.ziolkowski1@pg.edu.pl

**Abstract:** This work is based on a literature review (191). It mainly refers to two diagnostic methods based on artificial intelligence. This review presents new possibilities for using genetic algorithms (GAs) for diagnostic purposes in power plants transitioning to cooperation with renewable energy sources (RESs). The genetic method is rarely used directly in the modeling of thermal-flow analysis. However, this assignment proves that the method can be successfully used for diagnostic purposes. The GA method was presented in this work for thermal-flow studies of steam turbines controlled from the central power system to obtain the stability of RESs. It should be remembered that the development of software using genetic algorithms to locate one-off degradations is necessary for a turbine that works sustainably with RESs. In this paper, against the background of the review, diagnostic procedures create an inverse model of a thermal power plant. Algorithms were used to detect fast global extremes through the convergence of simulated signatures with signs explaining degradation. In addition, statistical dependencies are used in the selection phase to accelerate fault detection. The created procedure allows obtaining a diagnosis in the form of a single degradation. This procedure turns out to be quite effective for the above example.

**Keywords:** conventional power plant; diagnosis; thermal-flow diagnostics; genetic algorithm; renewable energy source



**Citation:** Ziółkowski, P.; Drosińska-Komor, M.; Głuch, J.; Breńkacz, Ł. Review of Methods for Diagnosing the Degradation Process in Power Units Cooperating with Renewable Energy Sources Using Artificial Intelligence. *Energies* **2023**, *16*, 6107. <https://doi.org/10.3390/en16176107>

Academic Editor: Anastasios Dounis

Received: 2 June 2023

Revised: 23 July 2023

Accepted: 12 August 2023

Published: 22 August 2023



**Copyright:** © 2023 by the authors. Licensee MDPI, Basel, Switzerland. This article is an open access article distributed under the terms and conditions of the Creative Commons Attribution (CC BY) license (<https://creativecommons.org/licenses/by/4.0/>).

## 1. Introduction

The continuous development of society has led to increased demand for electricity produced from various raw materials and resources [1,2]. Nonetheless, a mere fraction of electricity is produced from non-renewables, such as hard coal or nuclear fuel [3–5], which cooperate with renewable energy sources. However, the worldwide trends directed toward reducing carbon footprints promote sustainable development [6–8]. This development makes it necessary to reduce the emission of CO<sub>2</sub> [9,10] and other greenhouse gases, e.g., NO<sub>x</sub> and SO<sub>x</sub> [11]. This is important in meeting the climate requirements imposed by governments or global organizations [12,13]. As a result, the Paris Agreement [14] was created, the main goal of which is to prevent global warming [15,16]. Thus, power plants producing energy must operate at the highest possible and constant efficiency [17,18], taking into account green energy production [19] from nonstable wind and photovoltaic farms [20]. To achieve this, an appropriate diagnostic system is necessary [21], which will not only reveal failures [22,23] but also enable a high level of efficiency to be maintained when changing power [24,25].

This study focuses on conventional power plants, which should cooperate with renewable energy sources to achieve the work fluency of grid power systems. Most countries aim to significantly increase the share of renewables in electricity generation by 2050. Some

works report even 100% [26,27]. This approach leads to an increase in the installed capacity of renewable energy sources but also to an expansion of energy storage of various types [28]. However, given the scale of the power needed to be produced from RESs and stored, such a solution leads to unsustainable development. A better perspective is given by the gradual combination of classical cycles with renewable energy sources [29] or the creation of systems in which classical units support RES, as proposed in this work. From the point of view of sustainable development, it becomes reasonable to introduce exergy analyses [29,30] and biofuels for electricity production using optimization tools for the thermodynamic process [31,32].

In addition, an essential element in the sustainable use of energy technologies is the proper operation of existing machinery [33,34] without excessive damage and with adaptation to work with RESs. Power units possess a highly complex structure as they contain complicated facilities, particularly a steam turbine that experiences enhancement fatigue due to the rapid change of work regime. The costs of constructing and maintaining power units are costly, yet it is profitable to invest in these units due to earnings from energy sales [35,36]. Usually, engineers look for efficiency raised by cycle retrofit or construction modernization, e.g., improvement of maintained rotors in non-linear conditions [37,38] and more precise analysis of hydrodynamic bearing operation [39,40]. This procedure makes maintaining existing units at a high, stable level possible [41]. Minor efficiency changes, fluctuating within a hundredth percent, result in vast financial losses for power plants stemming from increased expenses for production, etc. [42]. The authors encountered this situation during their experimental investigations into power stations [43]. Diagnostic is used to maintain the steam power unit at a stable level, operating and generating power continuously [44]. In the case discussed, it is thermal-flow diagnostics. In the relevant literature, one can find scientific papers referring to and dealing with the topic of diagnostics of flow machines [45]. One of these is [44], showing the possibility of predicting the value of symptoms occurring in an automated diagnostic process, which was achieved by creating models using the theory of gray systems. Some authors of this study took part in the creation of a model enabling the heating process of the turbine shaft [46] so as not to exceed permissible stresses; in this case, genetic algorithms were used. These works show that the diagnostic process is very complicated, and research concerns a select few elements; it is only the most important components of the steam turbine and the entire cycle that are considered in this work. Again, for this purpose, genetic algorithms were used. The diagnostic process is also applied to low-power turbines with an organic Rankine Cycle (ORC) [47], where hybrids of the genetic algorithm were also used to improve the efficiency of the thermal object tested. In other papers, one can observe the use of the connection of the SVM (support vector machine) with the adaptive neuro-fuzzy inference system for diagnostic purposes. This shows that the topic of thermal-flow diagnostics is discussed in scientific works, but the diagnostic process of steam turbines using genetic algorithm-based methods has not been performed as of yet. In addition, the development of an assessment for turbomachinery is necessary alongside creating cooperation renewable energy sources with conventional power plants.

Thermal and flow diagnostics utilize information and knowledge stemming from the prognostics of industrial processes [48]. This knowledge consists of three fields:

- Operation [42,43];
- Technical Diagnostics [49];
- Automatics and Control [50].

Technical diagnostics in the power sector can be found in systems ensuring safety in a power plant [51]. It is also helpful in validating mathematical models for turbines used in electrical energy-generating systems [52,53] and cogeneration units [54]. Facilities in which technical diagnostics is applied include power plants, which can be found in techniques used for vibration analysis [55–57].

The use of diagnostics aims at the conduct of the diagnostic process with the appropriate accuracy. This process is carried out in three stages:

- Fault detection: detection or observation of a fault occurring in the object and determination of the detection time [58];
- Fault isolation: isolation, determination of type, size, and time of the fault's occurrence [59];
- Fault identification: determination of the size and character of the fault's variability in time [43].

However, diagnostic processes can be used to calibrate mathematical models of ejectors [60], turbines [61], and boilers [62], as well as entire energy systems [63,64]. In thermal and flow diagnostics, the diagnostic procedure depends on calculating the deviation of the measured value from the model value, resulting in a symptom being obtained [65]. A symptom is a relative deviation between measurement values, which is correct and corresponds to degradation. It is a measure of the quality of energy transformations and is used in thermal and flow diagnostics as well as other types of diagnostics. Power units consist of numerous complicated elements. Thus, the number of symptoms occurring there is very high. To accelerate calculations, symptoms are grouped in signatures. The correct operation signature and degradation signature have been distinguished [66]. The signatures can be treated as vectors explaining the reactions of the cycle to operational degradations. They constitute the input data processed by diagnostic relationships to obtain a diagnosis. If the performed diagnosis is satisfactory, one may accept it and apply the appropriate changes to operations [67].

There are various studies in the relevant literature on the diagnostic process of the combined system, but there are no studies on thermal-flow diagnostics of steam turbines using genetic algorithms. In other articles, methods of artificial neural networks prevail [68,69]. This work shows that genetic algorithms can be used for thermal-flow diagnostics, which is currently new to the authors' knowledge. In this literature, genetic algorithms are also used for optimization purposes in various aspects of energy. Chang [70] used a combination of neural networks and genetic algorithms to create a method of managing energy demand with a classical genetic algorithm. In the work [71], an extraterritorial genetic algorithm was used to evaluate water vapor injection. In the following paper with GA [72], the genetic algorithm of sustainability function was used to find the objective function for the optimization of multiple connected steam turbines and utility network systems. In the work [73], a study was carried out on the full overload of the Besat power plant. Genetic algorithms were used for single-criteria and multi-criteria optimization of the techno-economic characteristics occurring in the re-supply cycle of the power plant in question. In another work [74] using genetic algorithms for the multi-criteria optimization of energy systems, the Pareto front was used, although this was not included in this article. A proprietary version of the multi-objective genetic algorithm MOGA was created here, and the optimization process was confirmed for a simple cooling cycle that can be found in refrigerators or coolers. Genetic algorithms are also being developed to optimize individual devices (heat recovery steam generators) to ensure sustainable electricity production [75]. Genetic algorithms are also used in nuclear power plants. In the work [76], they were used in the optimization model and the failure physics model to describe the crack growth process of the steam generator pipe. The study by Panowski et al. [77] investigates converting a steam power plant into a cogeneration unit using absorption heat pump (AHP) technology. Two scenarios are compared: one with a dedicated heat exchanger (DHX) and the other using an AHP for heat production and recovery. Despite a small decrease in electricity production, the AHP scenario offers improved efficiency and a potential increase in total electricity generated by over 0.4%. The study performed by Diaz-Ramirez et al. [78] used a life-cycle assessment approach based on the exergy allocation factor, considering all life-cycle stages from construction to dismantling. The results showed that most of the environmental impact was attributed to electricity production, and the construction stage was the most impactful. Rusin et al. [79] discuss an online control system for managing stress in the pressure elements of a power unit, considering the variable heat transfer conditions. Cheng et al. [80] present a physics-informed domain adaptation network, called Adaptive



Fault Attention Residual Network (AFARN), for diagnosing faults in nuclear circulating water pump bearings. The AFARN refines features guided by bearing fault characteristics and minimizes the discrepancy of features' marginal and conditional distributions, aiding in generalizing the model from the source to target domain. Experiments on public and circulating water pump datasets demonstrate that AFARN enhances fault feature learning and diagnosis accuracy, offering an interpretable knowledge transfer between domains.

A novelty in this work is the presentation of various methods of diagnostic processes found in the literature. The diagnostic method of steam turbines based on the operation of genetic algorithms is in detail presented here. Genetic algorithms have so far not been widely used to obtain the diagnostic process of steam turbines, which is shown in this review.

### 1.1. Literature Gap

One of the most popular methods of obtaining diagnostic relationships of power units is artificial neural networks [81]. Apart from these, analytical and statistical methods are also used [82]. Analytical methods mainly relate to design calculations in nominal and partial load conditions to determine power, efficiency, and parameters in nominal conditions to compare with measurements, whether given by the turbine manufacturer or for operational measurements [83]. In addition, the analytical approach enables reference to the second law of thermodynamics. It indicates where losses occur in individual devices, such as a coal boiler or the entire cycle [84]. The methods shown make it possible to find the optimum efficiency while maintaining upper thermodynamic parameters and change the configuration of the whole cycle [85], rebuild the system to a different type of medium [86], or add a new system element [87]. Later, it can be verified after an experiment and using fuzzy logic [88] or artificial neural networks [89]. Although these methods help obtain satisfactory results, both have advantages and disadvantages.

Obtaining a diagnosis in the case of ANN enables all three phases of a diagnostic procedure to be found. ANN shows 97% efficiency and almost 100% identification accuracy in identifying degradation locations [42,49]. These results correspond with the site model with a multilayer perceptron, and a linear model of the unidirectional network should also be used for identification purposes. Despite the above advantages, ANN has some disadvantages: it necessitates network training, which is a long network learning process; lacks universality; has a large amount of data, learning the network each time after making changes in the tested facility; and always gives the result, which is a threat to novice researchers. A network training session can be conducted with or without a teacher (supervised/unsupervised learning) [68].

In the above case [90], data from numerical degradation simulation were used for ANN learning purposes [91,92]. The time-consuming process of organizing ANN for diagnostic relations is the main disadvantage of this approach [93,94]. Each long network training is burdensome. Thus, in the search for a more rapid preparation of diagnostic relations, attention has been paid to genetic algorithms. This method was comprehensively analyzed as a simulation study using data tuned to the experimental data of the thermal cycle model of the selected turbine [91]. Preparing data to train ANN took a few months of calculations, and in some cases, one training session lasted more than one day. Unfortunately, the ANN training was only suitable for the nearest turbine repair. Any other repair required new training data to be created. Moreover, ANN has other major disadvantages: preparing data for fifteen ANN training sessions [42,91] and the training sessions themselves are very time-consuming [48,49,95].

Additionally, new training is always necessary for any change in data in technical objects, for example, retrofit and repair [67]. The authors regard the new genetic algorithm (GA) method described in the paper as a possible means of eliminating at least some of the above weaknesses of the ANN method. GA has a shorter working time than ANN due to its neural network learning time.

The genetic method has rarely been used directly in thermal-flow diagnostic models. Here, it creates an opportunity to perform all three mentioned phases of diagnosis (fault detection, isolation, and identification). In this work, GA-based diagnostic procedures create an inverse model of a thermal power plant, which has been very rarely reported in any of the relevant literature (Table 1). To be able to present a literature gap on various possible methods of obtaining a diagnosis in steam, gas, and ORC turbines, the works on this topic are shown in the form of Table 1. It should be noted that in addition to these mentioned works on ANN [96], there are many further works [76,83,84,90,97] that have demonstrated some proven approaches to diagnosis, but due to their inadequacy, the authors decided to develop GA. However, it is worth mentioning that a new way of locating the degradation in the turbine is revealed, namely convolution neural networks [98], statistical iterative [85] and neural models [86], which is still unproven and may appear as promising as GA. Additionally, works that combine two methods, such as GA with the Finite Element Method (FEM) [87], increase the area of research. They are valuable and offer the possibility of developing diagnostics, but FEM-type analyses are time consuming. Their results depend on boundary conditions and models used to solve the problem. Hence, GA should be developed more in the direction proposed in this article.

Further methods used in the literature (Table 1) include fuzzy logic [87], deterministic simulations based on measurements [89], support vector machine [91], extreme learning machine [92], and hierarchical fuzzy CMAC neural network [99], but they are extremely sensitive to the measurement data provided and do not have the kind of verification proposed in this paper, involving parallel revision of the process with a second approach. The methods above were mainly related to steam turbines. However, analogous approaches along with the repeatability of their inadequacies can be found for gas turbines, as demonstrated in works [95,100–106]. Great prospects in steam turbine diagnostics are offered by the hybrid approach, in which the following should be distinguished: extreme learning machine-radial basis function networks [99], knowledge graph and Bayesian network [107], and the fusion of the support vector machine classifier with an adaptive neuro-fuzzy inference system classifier [73]. Work on gas turbines can be viewed from an analogous perspective [108–112].

**Table 1.** Summary of the literature review concerning the degradation of the turbomachinery cycle.

Author	Literature Source	Type of Analyzed Turbine: Steam and/or Gas and/or ORC	The Way of Locating the Degradation in the Turbine	Additional Remarks
Zhou et al.	[69]	Gas turbine	Convolution neural networks	
Fast, Palme'	[68]	Gas turbine with its heat recovery steam generator and a biomass-fueled boiler with its steam cycle	ANN	
Ślęzak-Żoźna, Głuch	[113]	Steam turbine	ANN	
Ślęzak-Żoźna, Głuch,	[100]	Steam turbine	ANN	
Drośnińska-Komor	[92]	Steam turbine	ANN	
Głuch	[95]	Steam turbine	ANN	
Gardzilewicz et al.	[101]	Steam turbine	Statistical iterative	
Butterweck, Głuch	[114]	Steam turbine	Neural model	Modeling CFD. Shape optimization of selected areas of the rotor of the high-pressure part of an ultra-supercritical steam turbine and the optimization of the turbine startup method.
Nowak, Rusin	[102]	Steam turbine	GA + FEM	



Table 1. Cont.

Author	Literature Source	Type of Analyzed Turbine: Steam and/or Gas and/or ORC	The Way of Locating the Degradation in the Turbine	Additional Remarks
Barelli et al.	[103]	The turbocharging system of a 1 MW internal combustion engine (I.C.E.)	The fuzzy logic	Specifically for the filters and compressor modules.
Zuming, Karimi	[104]	Combined cycle gas turbine (CCGT) power plants	Simulators such as GateCycle, Aspen HYSYS	
Zhou et al.	[105]	Gas turbine	Support vector machine	
Wong et al.	[106]	Gas turbine	Extreme learning machine	The comparison between extreme learning machines and support vector machines (SVM) was also made.
Yan et al.	[99]	Steam turbine generator	Hierarchical fuzzy CMAC neural network Matlab's built-in nonlinear unconstrained optimization algorithm	
Tsoutsanis et al.	[107]	Gas turbine	is known as "fminsearch" in the performance adaptation process.	Adaptive diagnostics method.
Tsoutsanis et al.	[108]	Gas turbine	The performance adaptation process.	A model that was developed in Matlab/Simulink.
Barad et al.	[109]	Gas turbine engine	Neural network	
Madhavan et al.	[110]	Aero gas turbine engine	Three-dimensional (3D) finite element (FE)	Turbine rotor blade vibration.
Kuo	[96]	Gas turbine	ANN and fuzzy Logic	Turbine blade faults in fan turbo-jet.
Aslanidou et al.	[111]	Micro gas turbine	Machine learning	
Sławiński et al.	[112]	Gas turbine	The COM-GAS numerical code and FEM	Presents the ravages of second rotor stage failure in a gas turbine.
Angelakis et al.	[115]	Gas turbine	ANN	Diagnose blade faults. Vibration, unsteady pressure, and acoustic measurements are used to diagnose turbine faults.
Aretakis et al.	[116]	Gas turbine	Wavelet analysis	
Li, Nilkitsaranont	[117]	Gas turbine	Non-linear diagnostic regression techniques, including both linear and quadratic models,	
Breikin et al.	[118]	Aero gas turbine engine	GA	Dynamic modeling.
Fentaye et al.	[119]	Gas turbine	Bayesian network	Used adaptive gas path analysis (AGPA). ELM-RBF was a comparison with back propagation neural network (BPNN).
Dhini et al.	[120]	Steam turbine	Extreme learning machine-radial basis function networks	
Yang et al.	[121]	Steam turbine	Knowledge graph and Bayesian network	

Table 1. Cont.

Author	Literature Source	Type of Analyzed Turbine: Steam and/or Gas and/or ORC	The Way of Locating the Degradation in the Turbine	Additional Remarks
Salahshoor et al.	[88]	Steam turbine	Fusion of a support vector machine classifier with an adaptive neuro-fuzzy inference system classifier,	The model was developed in the environment of Matlab/Simulink.
Zeng et al.	[122]	Gas turbine	Dynamic simulation model and Cuckoo search algorithm	
Salilew et al.	[123]	Gas turbine	Gas path non-linear steady-state model	
Yang et al.	[124]	Gas turbine	Kalman filter	
Asgari et al.	[125]	Gas turbine	ANN	
Mo et al.	[126]	Gas turbine	Fuzzy inference logic	
Zhang et al.	[127]	Steam turbine	Bayesian network	
Chmielniak and Trela	[128]	Steam turbine	ANN and Bayesian network	
Bzymek et al.	[129]	Steam turbine	Computational Solid Dynamic coupled Computational Fluid Dynamic	
Banaszkiewicz	[130]	Steam turbine	FEM + Duhamel's integral	
Banaszkiewicz	[131]	Steam turbine	probabilistic analysis and fracture mechanics considerations	Process of improving the safety and reliability of operation of the 18K370 steam turbines Opole Power Plant.
Banaszkiewicz and Rehmus-Forc	[132]	Steam turbine	Material testing and mechanical integrity calculations	
Kraszewski et al.	[133]	Spherical bifurcation pipe of a live steam	A one-sided numerical thermal-FSI analysis	
Badur et al.	[134]	Control stage in steam turbine	Studied analytically and numerically	Element of a block of coal-fired power plant working with a 18K370 turbine.
Badur et al.	[135]	Steam turbine-rotor and casting	Thermal-FSI (Fluid-Solid Interaction)	Combination of CFD + CSD, often called FSI (Fluid-Solid Interaction or Fluid-Structure Interaction).
Madejski et al.	[136]	Utility boilers	CFD calculations	
Blaut, Breńkacz	[137]	Rotor unbalance	Teager-Kaiser energy operator (TKEO)	
Andrearczyk et al.	[138]	Prototypical microturbine operating in an ORC-based power plant	Use LabVIEW	Vibrodiagnostic system designed.
Badur et al.	[139]	Heat exchanger	"Thermal-FSI" ("Fluid-Solid Interaction")	
Ziółkowski et al.	[140]	Steam and gas turbine	COM GAS	
Ziółkowski et al.	[141]	ORC	COM GAS	
Ziółkowski et al.	[142]	Steam turbine	ECO PG, CFD	
Lampart et al.	[143]	ORC	Hybrid algorithms	
Niksa-Rynkiewicz et al.	[144]	Gas turbine	ANN	



Then, the Bayesian network [127], Computational Fluid Dynamic coupled with Computational Solid Dynamic [135], FEM and Duhamel's integral [130], probabilistic analysis and fracture mechanics considerations [131], and material testing and mechanical integrity calculations [96] are used for steam turbines. However, this requires the preparation of full geometries and time-consuming and expensive tests for which there are often no resources or time in everyday work. For diagnostics, the precise computational analyses of a single element from the cycle are used, such as the spherical pipe of a live steam [133], the variable regime control stage of a 18K360 turbine [84], or the assembly of several turbine components including a rotor with a casting [142] and a steam boiler [59] (Table 1).

It is also important to support oneself with measurements [62,145] to verify the model, which without proper scopes can become unphysical, especially concerning GA. Therefore, works on steam, gas, and ORC turbines may be found in Table 1. ORC is the smallest number; however, gas and steam turbines are comparable for diagnostics purposes. Of course, reference should also be made to principal works in the literature. On their basis, the adopted models of individual devices should be checked [146] and moved to complex systems in nominal states [84], finalizing with the variable operating regimes of steam units. Hence, Table 1 presents other methods of use, e.g., 0D, 3D, stationary, and a transient approach, which allows the diagnostic process of the tested object. However, a more developed method is considered for the purposes mentioned in this paper.

### 1.2. Purpose and Structure of the Article

The above works show that genetic algorithms are used in many energy-related fields but were not used for thermal and flow diagnostics of steam turbines. In the literature on the subject, according to the authors' best knowledge, only the authors' works can be found concerning the thermal-flow diagnostics of steam turbines using genetic algorithms [12]. In this work, we have a multi-criteria optimization process that can be found in the above papers; additionally, in the presented article, the genetic algorithm was combined with a numerical program for calculating the parameters of thermal cycles. The works also contain combinations of genetic algorithms with other neural networks or programs. In this case, the algorithm was used to research the steam power plant cooperating with renewable energy sources.

The main purpose of this work was to present the possibility of using genetic algorithms for thermal-flow diagnostics of steam turbines, but the method can also be implemented both in gas and ORC turbines, nuclear power plants, and turbine power plants in ships. For presentation goals, the steam turbine was chosen because they are more complex and complicated than other fluid-flow machinery. The thermal-flow diagnostics can be used for applications requiring a turbine with a low, medium, and high-pressure part in a power plant cooperating with a nonstable wind and photovoltaic farm. To perform the diagnostic process, a numerical program for thermo-flow calculations, DIAGAR, was applied [66], which can identify damage to the turbine by combination with a genetic algorithm.

The most challenging stage of the work in the whole process was selecting the appropriate stage of the genetic algorithm. To make an assisted selection, characteristics were created to represent the selection process for power, unit heat consumption, average value, total value, skewness, and kurtosis. Based on these curves, it was possible to obtain a result. The algorithm is completed when at least one signature is less than five percent from the set signature. The authors determined this value, which can be treated as an additional novelty of this article.

The structure of the work is divided into four main sections. In Section 1, the review of work comprises different approaches to diagnostics. Section 2 considers the methodology for obtaining a diagnosis in thermal and flow systems with a presentation of the example for analysis strictly focused on the steam turbine. The information on the process receipt location and the identification of the degradation, demonstrating procedures for selecting the appropriate signatures of genetic algorithms, are reviewed in Section 3. Finally, Section 4 includes a summary of this paper and perspectives for future work development.



## 2. Methodology Obtaining a Diagnosis in Thermal and Flow System

This section presents the methodology where the genetic algorithms are placed first, together with the SWOT analysis for ANN and GA, indicating the validity of the adopted approach (Section 2.1). Section 2.2 describes the thermodynamic cycle that has been analyzed. The studied genetic procedures are detailed in Section 2.3.

### 2.1. Genetic Algorithms

Genetic algorithms have been known since 1975 when Holland presented the concept [147]. He gave an example of a simple algorithm, further developed by, among others, Goldberg [148].

Genetic algorithms are included in evolutionary algorithms [149,150] and are used to optimize complex systems [151]. In the relevant study, power units are systems like these. Typically, the process of optimization takes place in fields where a high number of variables are found, e.g., system design [152], economics [153], or transport [154]. These algorithms enable the global extremes [155] for a given function to be found quickly within its time domain [156,157].

Thermal and flow diagnostics utilize genetic algorithms for process optimization to cover the greatest possible data combination and then restrict them to the minimum during the following phase. This process is used to determine the minimum distance between the signature of the occurring degradation and the signature searching the degradation.

Each genetic algorithm consists of several subsequent stages. A simple algorithm, as proposed by Holland, consists of seven following stages:

- First, the whole algorithm is initiated by creating an initial population.
- Then, the chromosome adaptation in the population is assessed, and this concerns each chromosome in the population.
- The third stage concerns the stopping condition and depends on the method of applying a genetic algorithm. Two stopping conditions can occur. The first one occurs when the problem being analyzed involves an optimization task. Here, the decisive condition may be determining the optimum value (minimum or maximum). Another case may occur after the algorithm has been in operation for a specified time or when its operation does not lead to any improvement in the result obtained.
- The fourth stage introduces chromosome selection: to create a population, chromosomes with the highest value of adaptation are selected [158]. Ranking selection is used in thermal and flow diagnostics.
- The fifth stage concerns the genetic operator, which creates a population out of chromosomes obtained after the fourth stage. This is where the crossover and mutation operators can be distinguished. The crossover operator is more frequently used than the mutation operator [159].
- The penultimate stage involves creating a new population obtained after applying operators from the preceding stage. The new population can thus be subject to a specified action, i.e., checking the algorithm-stopping condition or introducing a specified chromosome.
- The last stage involves introducing the “best” chromosome; this occurs when the stopping condition is met. Such action enables the result for the entire genetic algorithm to be obtained [160].

A scheme for such an action has been used to create an algorithm for thermal and flow diagnostics. A SWOT analysis was performed for genetic algorithms (Table 2) and artificial neural networks (Table 3) in the power industry to support selecting the appropriate method. In the literature, you can find a lot of information about genetic algorithms and neural networks because both belong to artificial intelligence, which is still being developed. Based on this information, conclusions can be drawn about the advantages and disadvantages of both methods that are included in the SWOT analysis. The main advantage of genetic algorithms is the ability to solve complex systems with many elements [161]. This algorithm can be used for optimization [162,163]. It has a simple structure consisting of



seven steps [164]. This algorithm can be used in various fields of science [165–167]. The disadvantage of GA should be seen in the possibility of omitting a solution during the selection process [168] or a numerical error affecting the final result [169]. In the case of artificial neural networks, their advantage is the quick solving of complex systems [170,171] and the high availability of various types of networks [42,172] that can be used for the appropriate case [173,174]. In addition, they can find the solution to a diagnostic task with a small error [49]. However, the disadvantage is the need to train the network for a long time [175], having a very large amount of training data [176]. If the training data have errors, the result will also be incorrect.

**Table 2.** SWOT analysis of thermal-flow diagnostics using GA.

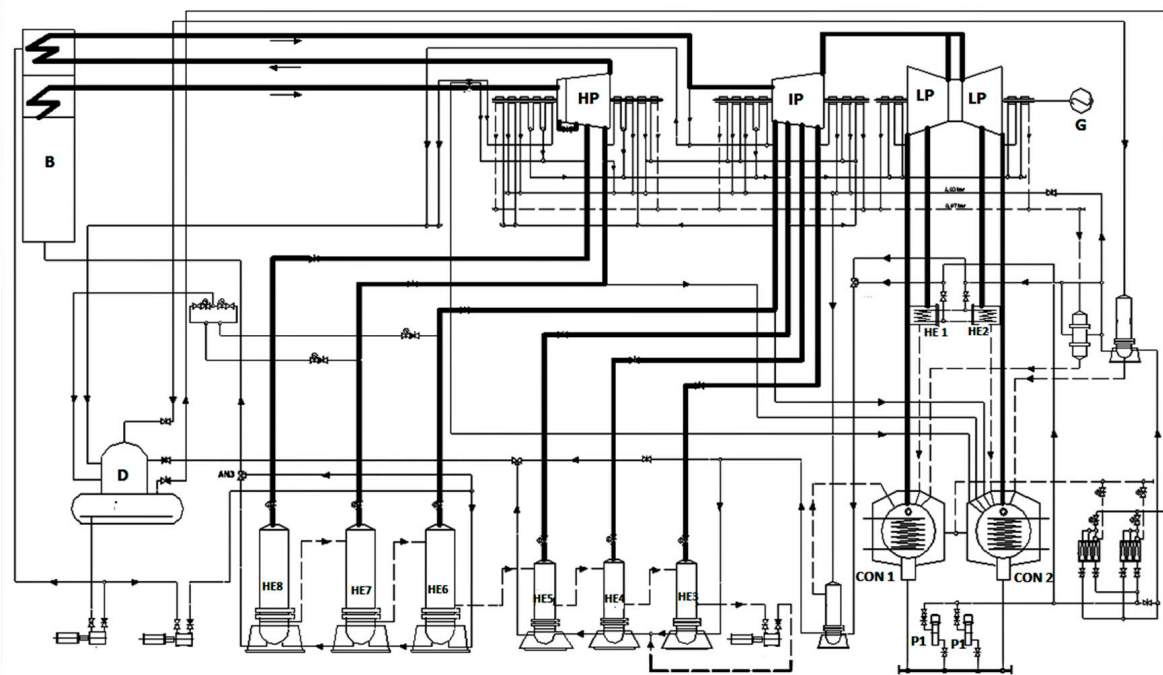
	Advantages	Disadvantages
Internal features	Strengths: <ul style="list-style-type: none"> <li>• solving complex systems with a large number of elements</li> <li>• the universality of the algorithm</li> <li>• speed of the method</li> <li>• simplicity of operation</li> <li>• can be used for the optimization</li> <li>• possibility of multiple repetitions of calculations</li> </ul>	Weaknesses: <ul style="list-style-type: none"> <li>• the possibility of omitting the solution during the selection</li> <li>• the occurrence of a numerical error</li> <li>• the occurrence of a measurement error affects the final result</li> </ul>
External factors	Opportunities: <ul style="list-style-type: none"> <li>• growing interest in artificial intelligence</li> <li>• can be used for other turbine and industrial facilities</li> <li>• a small number of applications</li> </ul>	Threats: <ul style="list-style-type: none"> <li>• numerical error</li> <li>• hardware limitations</li> <li>• due to its versatility, it is not as effective as specialized methods</li> </ul>

**Table 3.** SWOT analysis of thermal-flow diagnostics using ANN.

	Advantages	Disadvantages
Internal features	Strengths: <ul style="list-style-type: none"> <li>• solving complex systems, calculations</li> <li>• a large number of network types are available</li> <li>• finding a solution to a diagnostic task with a small error ([42,95] location of degradation 97%)</li> <li>• quick calculations for a trained network</li> </ul>	Weaknesses: <ul style="list-style-type: none"> <li>• the long network learning process</li> <li>• lack of universality: the necessity to conduct network training when changing the data, the research object</li> <li>• having a large amount of data</li> <li>• learning the network each time after making changes in the tested facility</li> <li>• always gives the result: a threat to novice researchers</li> </ul>
External factors	Opportunities: <ul style="list-style-type: none"> <li>• growing interest in artificial intelligence</li> <li>• extension of the method toward big data mining</li> </ul>	Threats: <ul style="list-style-type: none"> <li>• wrong data for network learning</li> <li>• in case of a large amount of data, the possibility of under-training</li> </ul>

## 2.2. Description of the Analyzed System

The study subject in the relevant work is a class 200 MW steam turbine (Figure 1). The turbine has been installed in a steam power unit in a power plant in Poland. In Poland, 80% of electricity is produced from solid resources (hard coal and lignite) [177]. However, this issue should be considered not only on a national scale or in view of non-renewable energy sources but also on a global scale because thermodynamic cycles, by whose example artificial neural networks have been trained, are also used in power plants using renewable energy sources, e.g., geothermal energy [178], solar energy [179] and wind energy in Compressed Air Energy Storage systems [180].



**Figure 1.** Cycle diagram with 200 MW class turbine, where: B—coil fired boiler, D—deaerator, G—electric generator, HP—high-pressure steam turbine, IP—intermediate pressure steam turbine, LP—low-pressure steam turbine, CON—steam condenser, P1—condensate pump, HE1–HE8—regenerative heat exchangers; The figure is based on [92].

The lines in the picture (Figure 1) stand for different working media pipelines. Measuring equipment is placed mainly on these pipelines. The parameters measured are characteristic of both changing conditions and geometry degradation caused by power unit exploitation. In the cycle diagram, there is a series of other devices used in the scheme, such as low-pressure regenerative heat exchangers (HE1–HE2), intermediate-pressure regenerative heat exchangers (HE3–HE5), high-pressure regenerative heat exchangers (HE6–HE7) and the steam condenser (CON).

The steam power unit in question possesses a three-casing turbine consisting of high (HP), intermediate (IP), and low-pressure (LP) parts. Seven stages of regenerative supply feedwater heating (HE1–HE7), thus seven regenerative extractions, are involved. The object was precisely measured: sensors were installed on steam and water pipelines. Thus, over 3000 pieces of data are almost instantaneously obtained, of which as many as 276 concern the steam cycle only. These sensors enable the following to be measured:

- Pressures;
- Mass flows;
- Temperatures;
- Currents and voltages supplying the motors installed on the power unit;
- Electric power.

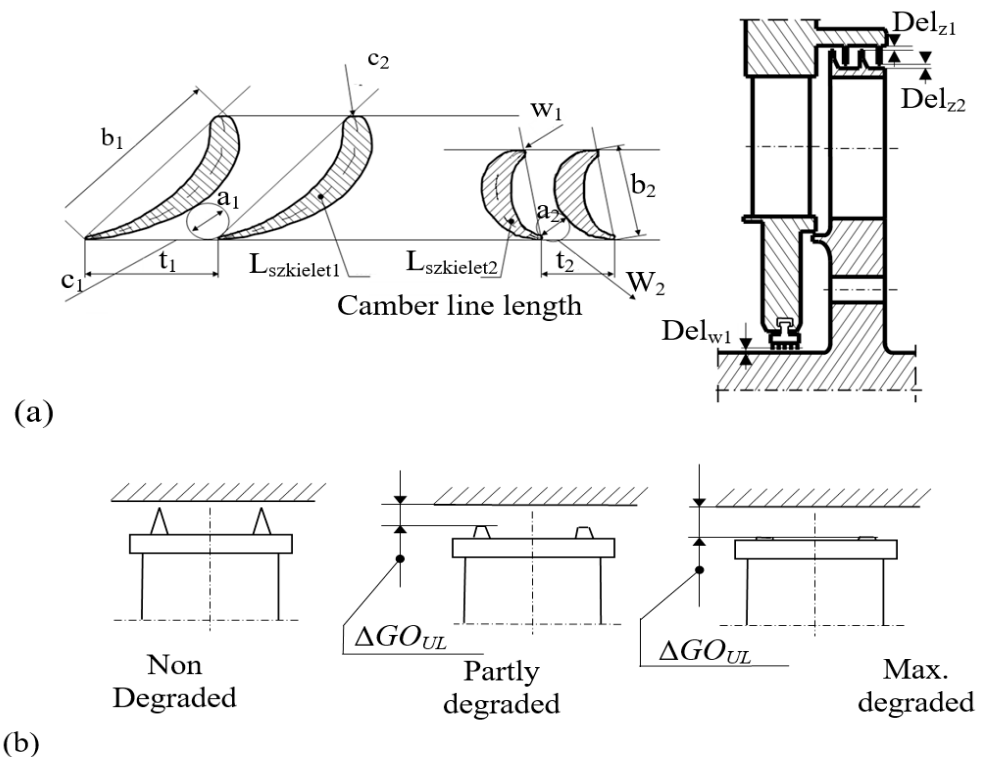
Usually, the measured data for thermal and flow diagnostics are obtained at the pipelines connecting related cycle components (Figure 1). These data vary constantly according to power unit load and some external data such as ambient parameters.

### 2.3. Studied Genetic Procedures

In search of degradation, a numerical program has been created based on the assumptions mentioned. This also uses a DIAGAR numerical code to calculate thermal cycles (presented in Figure 1). It should be emphasized that procedures for genetic algorithms are applied for this purpose. The difference between the procedure presented in this article and the original GA procedure is the method used to achieve the desired results. GA looks for optimized solutions, while the procedure presented knows the target and attempts to find conditions leading to this target. In the case of diagnostics, these are service conditions.

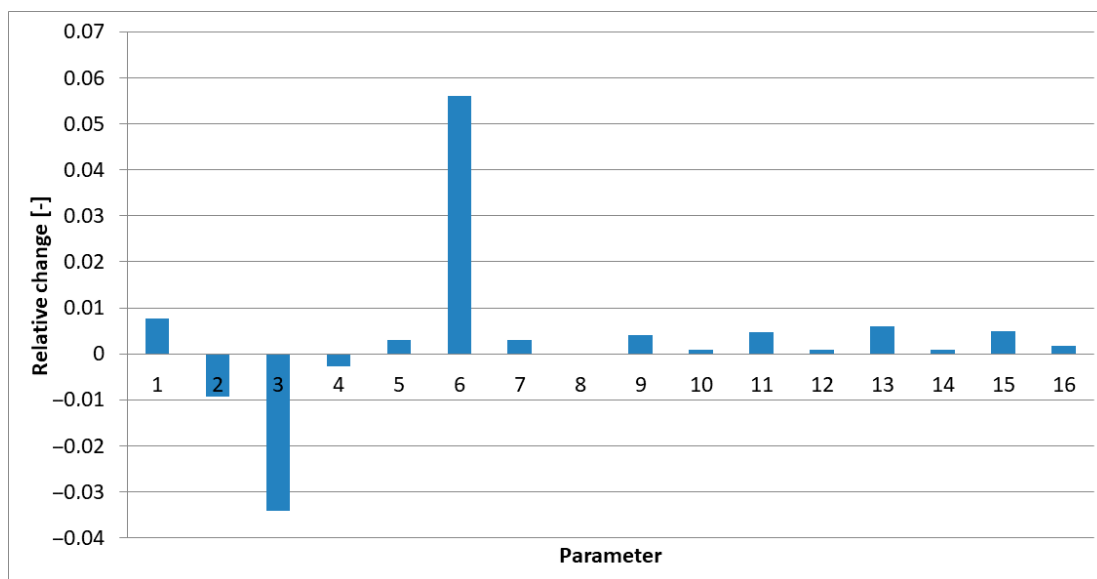
Therefore, the procedure presented, based on the genetic algorithm procedure, consists of eight stages:

1. The first stage of the software is to prepare geometric data sets (e.g., Figure 2) for the calculation process.
2. In the following phase, symptoms and signatures are determined by numerical simulation using the DIAGAR program.
3. The third stage involves simulating and sampling a single degradation and then determining symptoms and signatures for the degradation.



**Figure 2.** (a) Geometry of a turbine stage subjected to degradation where:  $a_1$ —stator throat diameter,  $b_1$ —stator chord,  $t_1$ —stator pitch,  $c_1$ —stator inlet absolute velocity,  $w_1$ —rotor inlet relative velocity,  $a_2$ —rotor throat diameter,  $b_2$ —rotor chord,  $t_2$ —rotor pitch,  $c_2$ —rotor outlet absolute velocity,  $w_2$ —rotor outlet absolute velocity,  $L_{szkielet1}$ —stator blade camber line length,  $L_{szkielet2}$ —rotor blade camber line length,  $Del_{z1}$ —stage external glands clearance,  $Del_{w1}$ —internal ordinary gland segment clearance; (b) the process of changing the degradation of seals = clearances; The figure is based on [181].

One characteristic signature corresponds to each complex degradation. For one of the signatures (Figure 3) considered in the study, 16 parameters are assigned. These 16 parameters are presented in Table 4.



**Figure 3.** An example of simulated degradation signatures of measurable parameters in the cycle caused by the maximum degradation of selected geometric parameters. The parameter's name specifies its deviation relative to a non-degraded state stemming from degradation—the numbers meaning according to the list in the text; The figure is based on [182].

**Table 4.** List of 16 parameters present in signature degradation [12].

Number Element	Name of Parameter
1	power deviation;
2	deviation of specific heat consumption;
3	steam pressure deviation at the I extraction;
4	steam temperature deviation at the I extraction;
5	steam pressure deviation at the II extraction;
6	steam temperature deviation at the II extraction;
7	steam pressure deviation at the III extraction;
8	steam temperature deviation at the III extraction;
9	steam pressure deviation at the IV extraction;
10	steam temperature deviation at the IV extraction;
11	steam pressure deviation at the V extraction;
12	steam temperature deviation at the V extraction;
13	steam pressure deviation at the VI extraction;
14	steam temperature deviation at the VI extraction;
15	steam pressure deviation at the VII extraction;
16	steam temperature deviation at the VII extraction.

The first three stages are used to prepare the initiation of calculation procedures.

4. The next step is to sample and perform crossover operations using geometric data subject to operational degradation. This aims to determine the component device of the cycle, for which crossover will be carried out and as a result of which the level of degradation formed is obtained.
5. After performing the above operations, a geometric data set is constructed for new data created after the crossover. At the moment, only one fault is analyzed, which can occur at any time on one of six component devices, for which six suitable searching signatures are created by performing six appropriate calculations for the relevant thermal cycle using DIAGAR software in preparation for the next phase.
6. In the sixth phase, the specialized software calculates symptoms for six datasets, accumulates them in six searching signatures, and then subjects them to the selection process.



7. In the seventh phase, the selection is carried out as mentioned earlier in the article. More precisely, the process consists of selecting the two signatures closest to the present signature. This assumption is met when the condition of a location below the minimum distance is met for at least one signature. It is one of the most difficult phases. Therefore, the authors made a big effort to accelerate and gain better accuracy of the recognition decision choosing signatures for further operation in proper order. For numerical procedures, finding appropriate single numbers defining each signature helped achieve the purpose mentioned above.
8. The moment of meeting such a condition is described as a solution. If this condition cannot be met, the fourth phase is repeated. This involves creating new data files on the two parameters closest to degradation. Files with data are subjected to the following phases mentioned above until a solution is obtained.

In accordance with the above procedure, a thermal flow diagnostic routine has been performed. Selection phase checking has been the primary purpose of these investigations. They have been based on numerical simulations constructed using the DIAGAR program, which has also helped to determine the reference state of the power unit in terms of its degraded characteristics caused by simulated exploitation geometry degradation. Values obtained in this way have been subjected to the procedure presented. At this stage of the investigation, attention has been focused on single geometry degradations, which means that only one possible degradation has occurred for one simulation. The data used in the seventh phase mentioned above have been applied in the Results section to select the closest degradation characteristic to the simulated one.

### 3. Procedure Selection and Creation of Characteristics

Geometry degradations occur in a real turbine and steam unit due to normal operational processes. Values of symptoms creating degradation stem from object measurements. For this paper, signatures have been determined in the process of simulating degradation calculations.

Changes to the values of the design geometry of cycle components are anticipated in a physically possible range that does not result in its emergency stop yet. Only the high-pressure (HP) and intermediate-pressure (IP) turbine casings were designated as power unit components subject to degradation. Among several hundred design geometry parameters, only the 22 mentioned below change their values as a result of degradation: HP nozzle boxes, seals of IP nozzle boxes, seals of the HP inner casing, and 16 values shown in Table 4 associated with the geometry of six groups of HP and IP stages and consisting, for each of these degree groups, of seals of inner turbine stages, their roughness and damage to the trailing edge.

Ten out of the above-mentioned parameters named in Table 4 are submitted to be presented in further parts of the paper. See also Table 5.

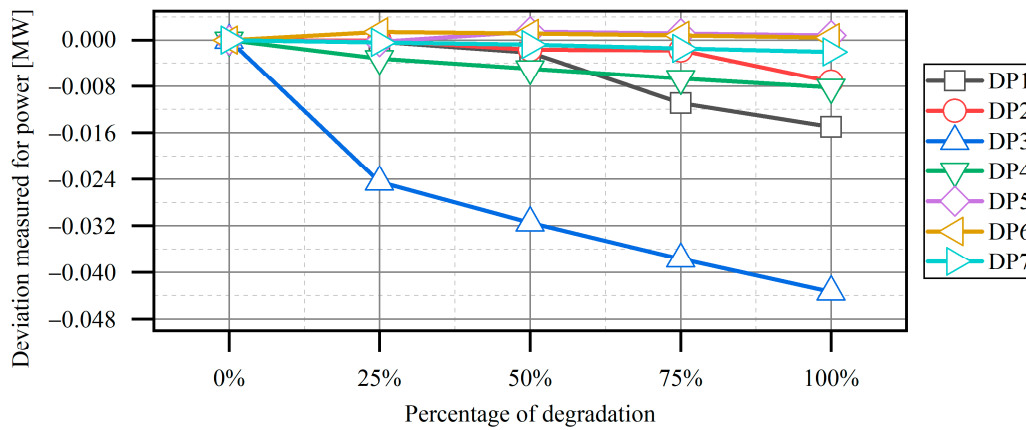
Their designed or simulated degraded values are introduced as data to the DIAGAR program. This code has been successfully used for failure study [41] and diagnostics of the thermodynamic cycle [43] and is currently being developed as EcoPG for the analysis of thermodynamic cycles with renewable energy sources [142]. In the first case, they are used to determine the signature of the correct operation (base signature), and in the second case, they aim to determine signatures of various degradations. Single-time degradations can be analyzed. Only one of the above geometric parameters is subject to degradation or multiple-time degradations when several parameters are subject to degradation at the same time. For this paper, only single-time degradations have been tested.

One genetic method involving artificial intelligence (AI) that is seldom reported in diagnostics has been studied as a diagnostic relation. This work creates a thermal power plant inverse model, which helps to find deterioration causes occurring during the operation of power units forming electricity generation systems.

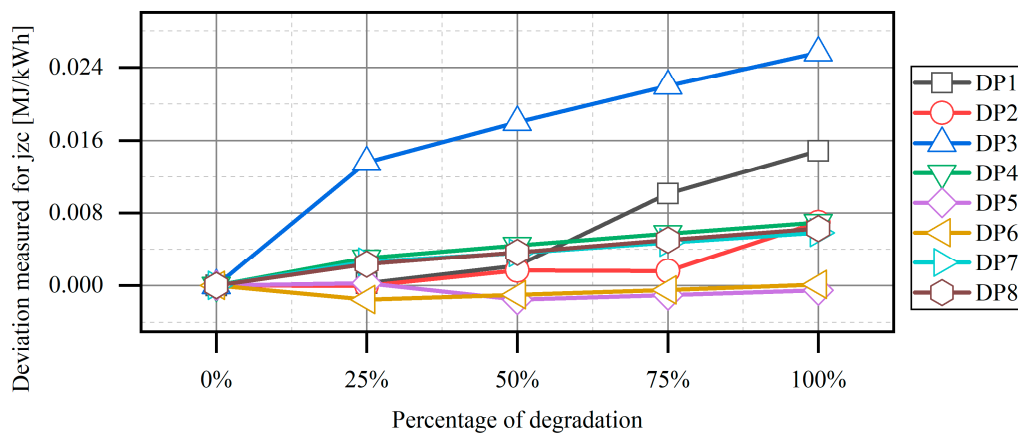


**Table 5.** Description of the degradations used for the selection procedure for Figures 4–9 [183].

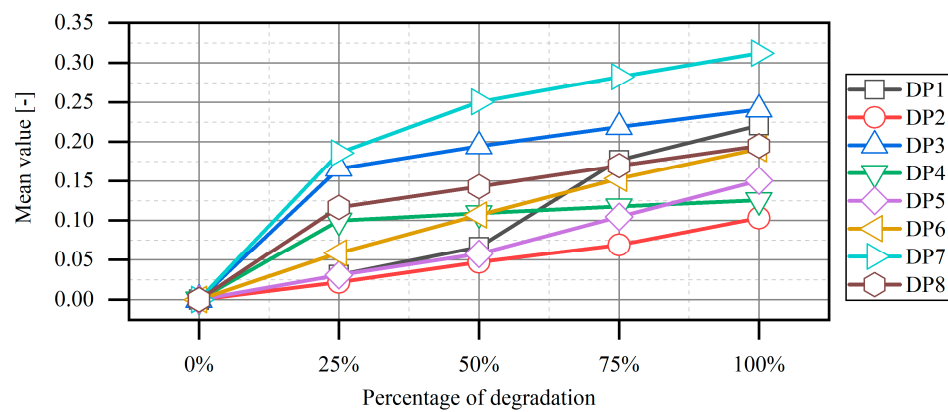
Symbol	Name	Degradation Description
□	DP1	Clearance in the seal of the control valve nozzle box for HP parts
○	DP2	Clearance in the outer seal of the HP part
△	DP3	Clearances in the seals for 1 stage group of HP parts
▽	DP4	Clearances in the seals for 2 stage group of HP parts
◇	DP5	Clearance in the sealing of the IP control valve nozzle box
△	DP6	Clearance in the external sealing of the IP part
▽	DP7	Clearances in the seals for 3 stage group of IP parts
○	DP8	Clearances in the seals for 4 stage group of IP parts
☆	DP9	Clearances in the seals for 5 stage group of HP parts
◇	DP10	Clearances in the seals for 6 stage group of HP parts



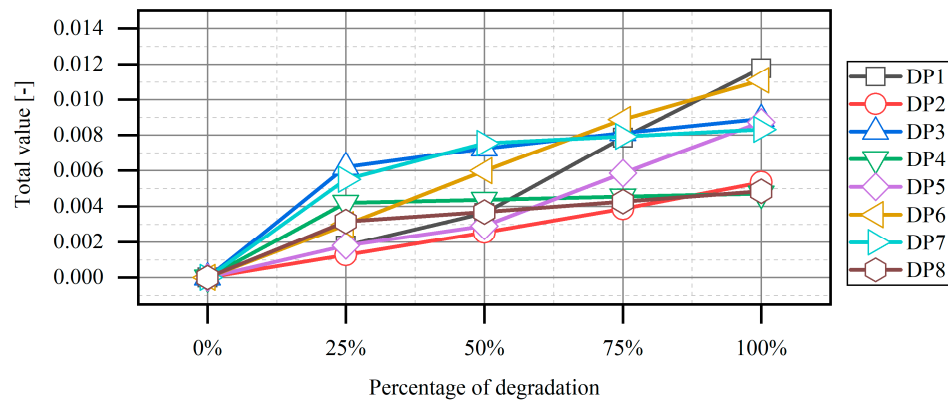
**Figure 4.** Characteristics presenting a power decrease vs. a degradation percentage for specific deterioration parameters; The figure is based on [183].



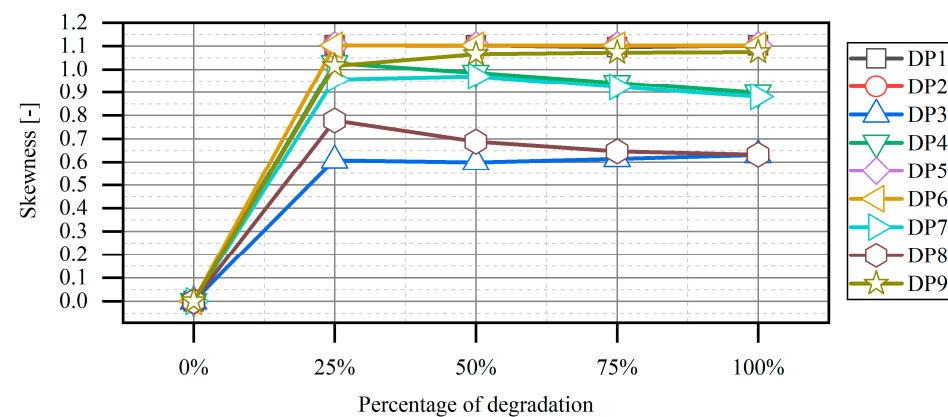
**Figure 5.** Characteristics presenting a specific heat consumption increase vs. a degradation percentage for specific deterioration parameters; The figure is based on [183].



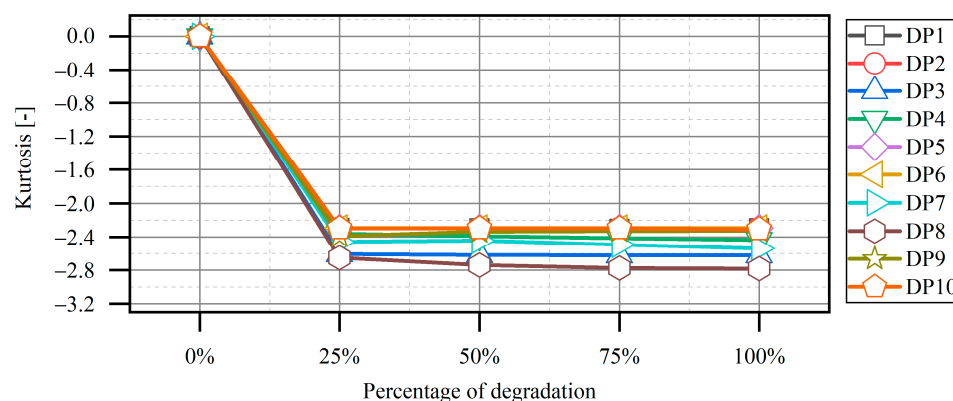
**Figure 6.** Characteristics presenting a mean value increase vs. a degradation percentage for specific deterioration parameters; The figure is based on [183].



**Figure 7.** Characteristics presenting a total value increase vs. a degradation percentage for specific deterioration parameters; The figure is based on [183].



**Figure 8.** Characteristics presenting a skewness change vs. a degradation percentage for specific deterioration parameters; The figure is based on [183].



**Figure 9.** Characteristics presenting a kurtosis change vs. a degradation percentage for specific deterioration parameters; The figure is based on [183].

### 3.1. Crossover Operations on Chromosomes—Values of Geometric Parameters

To identify and locate degradation, a dedicated calculation scheme has been used. The first stage of the system was to determine symptoms and improve calculations, which were grouped into signatures. The second task was to determine structural or geometric parameters for degrading turbines. The minimum and maximum values of each parameter were specified. Nominal values were designated as the minimum values, while the highest possible degradation values for the safe operation of the given element were designated as the maximum values. In the following phase, these values are presented in binary form. Number modifications are made by performing mutations so that their value remains within the range from minimum to maximum. Thus, populations are created. If the operations previously described have already been made, one should return to data representation in decimal form. The obtained data are entered as input data to the DIAGAR software. After the results are obtained, the present signature is compared with the received signature, and extremely deviant signatures are rejected, while the remaining ones and their corresponding geometric changes of structure are subject to assessment.

### 3.2. Selection

For the entire cycle, symptoms are obtained as a result of measurements. In the relevant study, they are created during operational degradation simulation. These tests are close to real ones in so much as the DIAGAR software is used, which is set up for actual measurements obtained from one of the power units of Polish power plants. Changes in structural geometry simulate operational degradation. The relevant study paid attention to the geometric degradation of selected HP and IP stage groups (Figure 2). Data concerning a turbine stage consist of 46 geometrics parameters. These data support the 1D theory of flow. Some are subject to operational degradation, while others are not subject to change during operations not threatened by critical failure. These variables primarily concern the limit dimensions of the flow channel and the geometry of blade mounts and seals. In addition, Figure 2 part b shows what the seals look like when there is no degradation (0%—Non-degraded), at 50% of the value (Partly degraded), and when the degradation reaches 100% (Max. degraded); then, the seals wear out completely.

Decimal numbers are then changed to binary, assuming that structural limits are not exceeded. Once sampled, the values obtained are returned to decimal. After executing a complete set of samples several times, the geometric data for calculations in the DIAGAR software are changed, and several groups of signatures used in search of a solution are determined by selection procedures.

Selection involves comparing signatures to find the solution described with the simulated degradation signature. As mentioned previously, comparing two numbers representing degradation signatures is helpful in the accuracy and acceleration of the finding of numerical procedures. Suppose the distance between one of the searching signatures



from the present signature is lower than expected. In that case, it is treated as a result of optimizing a task occurring in thermal and flow diagnostics. If this assumption is not met, the range of geometric data variability shall be reduced to the two closest values to the searching signature. The sampling, crossover, and selection operations are repeated until suitable results are obtained.

The selection of signatures (e.g., in Figure 3) not meeting convergence conditions when complete signatures are compared poses technical difficulties. Thus, the process has been divided into two stages:

- Preliminary selection based on selected characteristics;
- Final selection based on complete signatures.

The selected characteristics represented by single algebraic numbers have been listed below:

- Power: represented by value No. 1 from Figure 3;
- Efficiency: characterized by a reverse of specific heat consumption value No. 2 from Figure 3;
- Mean value: represented by statistical value (2nd statistical moment based on all deviations in signature), e.g., Figures 3 and 6;
- Skewness: defined by statistical value (3rd statistical moment based on all deviations in signature), e.g., Figures 3 and 8;
- Kurtosis: represented by statistical value (4th statistical moment based on all deviations in signature), e.g., Figures 3 and 9;
- Full signature: characterized by a sum of all deviations in signature, e.g., Figure 3.

### 3.3. Characteristics

An example of characteristics obtained during each selection procedure is presented in Figures 4–9. The algorithm of this selection has proven itself for the single-time degradations analyzed in this study. The symbols description used for the single degradation characteristics shown in Figures 4–9 is shown in Table 5.

The individual values in the graphs introduced above represent numerical and statistical characteristics of particular causes of degradation. The values depend on the size of the degradation. Collected on appropriate charts, they show distributions characteristic for various causes of degradation, creating degradation lines. In different graphs, the degradation lines differ in a significant way. This makes it possible to distinguish the causes of degradation. Therefore, it supports selection procedures. The specific cause of degradation sought is characterized by a set of single numbers corresponding to the terms in Figures 5–9. They can be positioned as points on appropriate graphs. This observation ultimately expands the distinguishability of the causes of degradation and completes the selection stage in the primary genetic algorithm, improving its functioning.

Results of studies on degradation were obtained using the above procedure, which is more precisely described in Section 2.1. It should be remembered that only numerical simulations of degradation were studied, which stand for error-free measurements of thermal cycles. As mentioned above, these concerned only the single degradation. Single degradation investigations are the first step toward developing a final diagnostic procedure. The calculation of both genetic and energy cycles was relatively simple in this case. By contrast, the resolution problem has, in the meantime, been given arbitrarily, and it has been used to study the selection procedure. The results of this selection depend on the characteristics of signature degradation. Those for which the characteristics shown in the charts in Figures 4–9 are more significant are better recognizable in the case of single degradation of flow channel geometry. Kurtosis and skewness (Figures 8 and 9) proved particularly useful for this study.

The recognition of the most influential degradation on the characteristics shown in Figures 4–9 has been high speed; only one iteration was sufficient to notice the cause of





degradation. This applies to the degradation of the control valve and external turbine glands.

The remaining causes of degradation have been observed in two or three iterations, and it has been necessary to consider more than one of the characteristics from Figures 4–9 to assist in recognizing the cause of degradation.

#### 4. Summary and Perspective

The review presented in the paper demonstrates that genetic algorithms rarely used in diagnostics can be utilized for obtaining a diagnosis of TFD. The described method fulfills its task in single degradations, enabling it to obtain a result for multiple degradations. This procedure has proved to be quite effective for the case above. In some examples, the degradation can be recognized in only one iteration. For less distinguishable causes of degradation, the number of iterations is slightly higher. As it has emerged in the review, the crucial advantage of the GA procedure is that it enables a diagnosis for the relevant object to be found more quickly than in the case of ANN despite their excellent accuracy. This is because the time-consuming network training stage is eliminated. This review provides scope for further development of the diagnostic approach to recognizing causes of multiple degradations.

Perspective investigations concerning the selection phase performed for so-called multiple degradations—when more than one degradation cause occurs—are much more complicated. This situation tends to arise in real machines, and the final signature of multiple degradations is the sum of single degradation signatures. Unfortunately, the relations are not linear and therefore require further intensive investigation, which is currently at the development stage. The presented method of genetic algorithms usage with the proposed new approach to selection phase improvement shows the possibility of its application for diagnostic purposes.

Nowadays, the appropriate diagnostics for power units are becoming particularly important. Conventional power units are being displaced from the order of merit and are giving way to an electricity regulator for electricity generating systems in co-operation with Renewable Energy Sources (RESs). In such a situation, power units operate under off-design loads and not under widely known design parameters. Very often, an operation is moved to variable load regimes of the turbine and boiler, sometimes even exceeding the limits. This greatly increases the risk of failure. In this context, appropriate diagnostics of the power units ensure the safety of continuous, unbroken operation. In addition, proper heat-flow modeling and extension of this issue for diagnostic is decisive in modernizing power units for reducing their greenhouse footprint through carbon capture.

Additionally, this may help heat, chemical, and electrical energy storage systems to be produced correctly and safely. The above DIAGAR code is being converted from conventional operation to co-operation with RES units. In this way, steam power units can stabilize the electricity grid during power changes. They can also support electricity storage with methanol from captured CO<sub>2</sub> using photovoltaics and wind farms to deliver H<sub>2</sub>.

In addition, the GA can be used for diagnostic testing and the reliability of systems in combined systems, nuclear power plants, or steam power plants on ships. Therefore, it is possible to extend genetic algorithms to other areas of the industry, not only the energy industry.

The current trend in many countries is to move away from conventional coal-fired power plants and replace them with renewable energy sources or atomic energy, among others. This is related to the energy policy of individual countries worldwide, especially in the European Union. At the same time, efforts are being made to reduce man-made pollution. One of the solutions allowing the simultaneous disposal of waste sludge, electricity generation, and CO<sub>2</sub> capture is the introduction of BECCS (BioEnergy with Carbon Capture and Storage) systems [184,185], an example of which is the nCO<sub>2</sub>PP cycle [186,187]. Significant growth in interest with prospects for development is also given by systems based on the recovery of waste thermal energy [188] or the capture of geothermal power [146,189]. For many countries, shifting away from conventional energy sources is a significant challenge.



Therefore, the creation of the energy mix should be completed concerning the available technology. Thus, it is necessary to look for solutions that allow the longest and most efficient use of current systems of classical power plants with their cooperation with new technologies. Developments related to their possible modifications, e.g., in combination with renewable energy sources or the use of CO<sub>2</sub> capture, should be combined with the trend of proper diagnostics. With the emergence of such megatrends, applying the GA-based diagnostic system presented in the paper becomes important. Because the mentioned power generation arrangements in the mix are characterized by a significant level of complexity in diagnostics, there will be trends in the use of technology indicating the detection of multiple degradation cases. In addition, there is expected to be a strong trend in the development of diagnostics in respect of energy storage both in terms of the reliability of energy storage and the economical way of charging and discharging [190,191].

Innovative applications of the proposed artificial intelligence method in building modern diagnostic relations in thermal-flow diagnostics affect the development of technical disciplines related to the operation of energy facilities.

**Author Contributions:** Conceptualization, P.Z.; methodology, P.Z. and J.G.; software, M.D.-K.; validation, M.D.-K. and P.Z.; formal analysis, P.Z. and J.G.; investigation, P.Z. and M.D.-K.; writing—original draft preparation, M.D.-K. and P.Z.; writing—review and editing, J.G. and Ł.B.; visualization, M.D.-K. and Ł.B.; supervision, P.Z.; funding acquisition, P.Z., project administration, P.Z. All authors have read and agreed to the published version of the manuscript.

**Funding:** Financial support of these studies from Gdańsk University of Technology by the DEC-50/2020/IDUB/I.3.3 grant under the ARGENTUM TRIGGERING RESEARCH GRANTS-EIRU program is gratefully acknowledged. Part of the paper was created within the framework of the ACTIVATING project entitled “Aktywne łożyska foliowe ze zmiennymi właściwościami dynamicznymi” (Eng. Active foil bearings with variable dynamic properties), agreement no. LIDER/51/0200/L9/17/NCBR/2018, implemented as part of the research and development programme called “LIDER” (Eng. LEADER).

**Data Availability Statement:** The data presented in this study are available on request from the corresponding author.

**Conflicts of Interest:** The authors declare no conflict of interest.

## Nomenclature

a1	Stator throat diameter
a2	Rotor throat diameter
AGPA	Adaptive gas path analysis
AHP	Absorption heat pump
AFARN	Adaptive Fault Attention Residual Network
AI	Artificial intelligence
ANN	Artificial neural networks
B	Coal-fired boiler
b1	Stator chord
b2	Rotor chord
BECCS	BioEnergy with Carbon Capture and Storage
BPNN	Back propagation neural network
C1	Stator absolute velocity
C2	Rotor outlet absolute velocity
CCGT	Combined cycle gas turbine
CFD	Computational Fluid Dynamics
CMAC	Cerebellar Model Articulation Controller
CON	Steam condenser
D	Deaerator
Delz1	Stage external glands clearance

Delw1	Internal ordinary gland segment clearance
DHX	Dedicated heat exchanger
DP	Degradation parameter
ECO PG	Program name from Ecological Poli-Generation systems
FEM	Finite Element Method
FSI	Fluid–Solid Interaction
G	Electric generator
GA	Genetic algorithms
HE	Regenerative heat exchangers
HP	High-pressure steam turbine
I.C.E.	Internal combustion engine
IP	Intermediate pressure steam turbine
Lszkiel1	Stator blade camber line length
Lszkiel2	Rotor blade camber line length
LP	Low pressure steam turbine
MOGA	Multi-objective genetic algorithm
ORC	Organic Rankine Cycle
P1	Condensate pump
RES	Renewable Energy Sources
SWOT	Strengths–Weaknesses–Opportunities–Threats
SVM	Support vector machines
t1	Stator pitch
t2	Rotor pitch
TFD	Thermal-Flow Diagnostics
TKEO	Teager–Kaiser energy operator
w1	Rotor inlet relative velocity
w2	Rotor outlet relative velocity

## References

- Suo, M.Q.; Li, Y.P.; Huang, G.H. Multicriteria Decision Making under Uncertainty: An Advanced Ordered Weighted Averaging Operator for Planning Electric Power Systems. *Eng. Appl. Artif. Intell.* **2012**, *25*, 72–81. [\[CrossRef\]](#)
- Javadi, M.; Jafari, N.; Khalili, M.; Jabery, R. 4E Analysis of Three Different Configurations of a Combined Cycle Power Plant Integrated with a Solar Power Tower System. *Sustain. Energy Technol. Assess.* **2021**, *48*, 101599. [\[CrossRef\]](#)
- Drośnińska-Komor, M.; Głuch, J.; Breńkacz, L.; Ziółkowski, P. On the Use of Selected 4th Generation Nuclear Reactors in Marine Power Plants. *Polish Marit. Res.* **2022**, *29*, 76–84. [\[CrossRef\]](#)
- Szewczuk-Krypa, N.; Drośnińska-Komor, M.; Głuch, J.; Breńkacz, L. Comparison Analysis of Selected Nuclear Power Plants Supplied With Helium from High-Temperature Gas-Cooled Reactor. *Polish Marit. Res.* **2018**, *25*, 204–210. [\[CrossRef\]](#)
- Madejski, P.; Taler, D.; Taler, J. Thermal and Flow Calculations of Platen Superheater in Large Scale CFB Boiler. *Energy* **2022**, *258*, 124841. [\[CrossRef\]](#)
- Karaçor, M.; Uysal, A.; Mamur, H.; Günnur, S. Life Performance Prediction of Natural Gas Combined Cycle Power Plant with Intelligent Algorithms. *Sustain. Energy Technol. Assess.* **2021**, *47*, 101398. [\[CrossRef\]](#)
- Bae, S.J.; Mun, B.M.; Chang, W.; Vidakovic, B. Condition Monitoring of a Steam Turbine Generator Using Wavelet Spectrum Based Control Chart. *Reliab. Eng. Syst. Saf.* **2019**, *184*, 13–20. [\[CrossRef\]](#)
- Witanowski, Ł.; Ziółkowski, P.; Klonowicz, P.; Lampart, P. A Hybrid Approach to Optimization of Radial Inflow Turbine with Principal Component Analysis. *Energy* **2023**, *272*, 127064. [\[CrossRef\]](#)
- Mukoni, E.; Garner, K.S. Multi-Objective Non-Dominated Sorting Genetic Algorithm Optimization for Optimal Hybrid (Wind and Grid)-Hydrogen Energy System Modelling. *Energies* **2022**, *15*, 7079. [\[CrossRef\]](#)
- Madejski, P.; Chmiel, K.; Subramanian, N.; Kuś, T. Methods and Techniques for CO<sub>2</sub> Capture: Review of Potential Solutions and Applications in Modern Energy Technologies. *Energies* **2022**, *15*, 887. [\[CrossRef\]](#)
- Ziółkowski, P.; Głuch, S.; Ziółkowski, P.J.; Badur, J. Compact High Efficiency and Zero-Emission Gas-Fired Power Plant with Oxy-Combustion and Carbon Capture. *Energies* **2022**, *15*, 2590. [\[CrossRef\]](#)
- Drośnińska-Komor, M.; Głuch, J.; Brzezińska-Gołębiewska, K.; Piotrowicz, M.; Ziółkowski, P. Conditions for Increasing the Recognition of Degradation in Thermal-Flow Diagnostics, Taking into Account Environmental Legal Aspects. *J. Power Technol.* **2023**, *103*, 33–48.
- Kaushik, E.; Prakash, V.; Mahela, O.P.; Khan, B.; Abdelaziz, A.Y.; Hong, J.; Geem, Z.W. Optimal Placement of Renewable Energy Generators Using Grid-Oriented Genetic Algorithm for Loss Reduction and Flexibility Improvement. *Energies* **2022**, *15*, 1863. [\[CrossRef\]](#)

14. Skowron, Ł.; Chygryn, O.; Gašior, M.; Koibichuk, V.; Lyeonov, S.; Drozd, S.; Dluhopolskyi, O. Interconnection between the Dynamic of Growing Renewable Energy Production and the Level of CO<sub>2</sub> Emissions: A Multistage Approach for Modeling. *Sustainability* **2023**, *15*, 9473. [\[CrossRef\]](#)
15. Fernández, J.R. An Overview of Advances in CO<sub>2</sub> Capture Technologies. *Energies* **2023**, *16*, 1413. [\[CrossRef\]](#)
16. Ekardt, F.; Roos, P.; Bärenwaldt, M.; Nesselhauf, L. Energy Charter Treaty: Towards a New Interpretation in the Light of Paris Agreement and Human Rights. *Sustainability* **2023**, *15*, 5006. [\[CrossRef\]](#)
17. Szewczuk-Krypa, N.; Grzymkowska, A.; Głuch, J. Comparative Analysis of Thermodynamic Cycles of Selected Nuclear Ship Power Plants with High-Temperature Helium-Cooled Nuclear Reactor. *Polish Marit. Res.* **2018**, *25*, 218–224. [\[CrossRef\]](#)
18. Özgür-Ünlüakın, D.; Türkali, B.; Karacaörenli, A.; Çağlar Aksezer, S. A DBN Based Reactive Maintenance Model for a Complex System in Thermal Power Plants. *Reliab. Eng. Syst. Saf.* **2019**, *190*, 106505. [\[CrossRef\]](#)
19. Gotzman, S.; Ziółkowski, P.; Badur, J. Evaluation of Long-Term Start up Costs Impact on Short-Term Price Based Operational Optimization of a CCGT Using MILP. *E3S Web Conf.* **2019**, *137*, 01012. [\[CrossRef\]](#)
20. Woolley, E.; Luo, Y.; Simeone, A. Industrial Waste Heat Recovery: A Systematic Approach. *Sustain. Energy Technol. Assess.* **2018**, *29*, 50–59. [\[CrossRef\]](#)
21. Chen, Z.; Zhou, D.; Zio, E.; Xia, T.; Pan, E. Adaptive Transfer Learning for Multimode Process Monitoring and Unsupervised Anomaly Detection in Steam Turbines. *Reliab. Eng. Syst. Saf.* **2023**, *234*, 109162. [\[CrossRef\]](#)
22. Liu, X.; Sun, Q.; Ye, Z.S.; Yildirim, M. Optimal Multi-Type Inspection Policy for Systems with Imperfect Online Monitoring. *Reliab. Eng. Syst. Saf.* **2021**, *207*, 107335. [\[CrossRef\]](#)
23. Breńkacz, Ł.; Bagiński, P.; Adamowicz, M.; Giziewski, S. Failure Analysis of a High-Speed Induction Machine Driven by a SiC-Inverter and Operating on a Common Shaft with a High-Speed Generator. *Eksploat. I Niezawodn.–Maint. Reliab.* **2022**, *24*, 177–185. [\[CrossRef\]](#)
24. Yang, T.; Wang, W.; Zeng, D.; Liu, J.; Cui, C. Closed-Loop Optimization Control on Fan Speed of Air-Cooled Steam Condenser Units for Energy Saving and Rapid Load Regulation. *Energy* **2017**, *135*, 394–404. [\[CrossRef\]](#)
25. Madejski, P.; Michalak, P.; Karch, M.; Kuś, T.; Banasiak, K. Monitoring of Thermal and Flow Processes in the Two-Phase Spray-Ejector Condenser for Thermal Power Plant Applications. *Energies* **2022**, *15*, 7151. [\[CrossRef\]](#)
26. Vidinopoulos, A.; Whale, J.; Fuentes, U. Assessing the Technical Potential of ASEAN Countries to Achieve 100% Renewable Energy Supply. *Sustain. Energy Technol. Assess.* **2020**, *42*, 100878. [\[CrossRef\]](#)
27. Ziółkowski, P.; Stasiak, K.; Amiri, M.; Mikielewicz, D. Negative Carbon Dioxide Gas Power Plant Integrated with Gasification of Sewage Sludge. *Energy* **2023**, *262*, 125496. [\[CrossRef\]](#)
28. Rahimzadeh, A.; Christiaanse, T.V.; Evins, R. Optimal Storage Systems for Residential Energy Systems in British Columbia. *Sustain. Energy Technol. Assess.* **2021**, *45*, 101108. [\[CrossRef\]](#)
29. Peng, M.Y.; Chen, C.; Peng, X.; Marefati, M. Energy and Exergy Analysis of a New Combined Concentrating Solar Collector, Solid Oxide Fuel Cell, and Steam Turbine CCHP System. *Sustain. Energy Technol. Assess.* **2020**, *39*, 100713. [\[CrossRef\]](#)
30. Amrollahi, Z.; Ystad, P.A.M.; Ertesvåg, I.S.; Bolland, O. Optimized Process Configurations of Post-Combustion CO<sub>2</sub> Capture for Natural-Gas-Fired Power Plant—Power Plant Efficiency Analysis. *Int. J. Greenh. Gas Control* **2012**, *8*, 1–11. [\[CrossRef\]](#)
31. Sanaye, S.; Khakpaay, N.; Chitsaz, A. Thermo-Economic and Environmental Multi-Objective Optimization of a Novel Arranged Biomass-Fueled Gas Engine and Backpressure Steam Turbine Combined System for Pulp and Paper Mills. *Sustain. Energy Technol. Assess.* **2020**, *40*, 100778. [\[CrossRef\]](#)
32. Ziółkowski, P.; Badur, J.; Pawlak-Kruczek, H.; Stasiak, K.; Amiri, M.; Niedzwiecki, Ł.; Krochmalny, K.; Mularski, J.; Madejski, P.; Mikielewicz, D. Mathematical Modelling of Gasification Process of Sewage Sludge in Reactor of Negative CO<sub>2</sub> Emission Power Plant. *Energy* **2021**, *224*, 122601. [\[CrossRef\]](#)
33. Habibi, R.; Pourfayaz, F.; Mehrpooya, M.; Kamali, H. A Natural Gas-Based Eco-Friendly Polygeneration System Including Gas Turbine, Sorption-Enhanced Steam Methane Reforming, Absorption Chiller and Flue Gas CO<sub>2</sub> Capture Unit. *Sustain. Energy Technol. Assess.* **2022**, *52*, 101984. [\[CrossRef\]](#)
34. Rusin, A.M. Technical Risk Involved in Long-Term Operation of Steam Turbines. *Reliab. Eng. Syst. Saf.* **2007**, *92*, 1242–1249. [\[CrossRef\]](#)
35. Valero, A.; Correas, L.; Zaleta, A.; Lazzaretto, A.; Verda, V.; Reini, M.; Rangel, V. On the Thermo-economic Approach to the Diagnosis of Energy System Malfunctions Part 2. Malfunction Definitions and Assessment. *Energy* **2004**, *29*, 1889–1907. [\[CrossRef\]](#)
36. Ghaffari, A.; Chaibakhsh, A.; Lucas, C. Soft Computing Approach for Modeling Power Plant with a Once-through Boiler. *Eng. Appl. Artif. Intell.* **2007**, *20*, 809–819. [\[CrossRef\]](#)
37. Breńkacz, Ł.; Żywica, G.; Drosińska-Komor, M. The Experimental Identification of the Dynamic Coefficients of Two Hydrodynamic Journal Bearings Operating at Constant Rotational Speed and Under Nonlinear Conditions. *Polish Marit. Res.* **2017**, *24*, 108–115. [\[CrossRef\]](#)
38. Breńkacz, Ł.; Żywica, G. Comparison of Experimentally and Numerically Determined Dynamic Coefficients of the Hydrodynamic Slide Bearings Operating in the Nonlinear Rotating System. In Proceedings of the ASME Turbo Expo 2017: Turbomachinery Technical Conference and Exposition, Charlotte, NC, USA, 26 June 2017; Volume 7A: Struct, pp. 1–12.



39. Breńkacz, Ł.; Żywica, G.; Drosińska-Komor, M.; Szewczuk-Krypa, N. The Experimental Determination of Bearings Dynamic Coefficients in a Wide Range of Rotational Speeds, Taking into Account the Resonance and Hydrodynamic Instability. In *Dynamical Systems in Applications*; Awrejcewicz, J., Ed.; Springer Proceedings in Mathematics & Statistics; Springer International Publishing: Cham, Switzerland, 2018; Volume 249, pp. 13–24. ISBN 978-3-319-96600-7.
40. Breńkacz, Ł.; Żywica, G. The Sensitivity Analysis of the Method for Identification of Bearing Dynamic Coefficients. In *Dynamical Systems: Modelling*; Springer: Berlin/Heidelberg, Germany, 2016; pp. 81–96.
41. Błaszczak, A.; Głuch, J.; Gardzilewicz, A. Operating and Economic Conditions of Cooling Water Control for Marine Steam Turbine Condensers. *Polish Marit. Res.* **2011**, *18*, 48–54. [[CrossRef](#)]
42. Głuch, J. Fault Detection in Measuring Systems of Power Plants. *Polish Marit. Res.* **2008**, *15*, 45–51. [[CrossRef](#)]
43. Głuch, J.; Ślęzak-Żołna, J. Solving Problems with Patterns for Heat and Flow Diagnostics Dedicated for Turbine Power Plants. In Proceedings of the International Gas Turbine Institute Proceedings ASME Turbo Expo 2012, Copenhagen, Denmark, 11–15 June 2012; Volume 1, pp. 969–979.
44. Tabaszewski, M.; Cempel, C. Using a Set of GM (1, 1) Models to Predict Values of Diagnostic Symptoms. *Mech. Syst. Signal Process.* **2015**, *52–53*, 416–425. [[CrossRef](#)]
45. Geete, A.; Khandwawala, A.I. To Analyse the Combined Effect of Different Extraction Line Pressure Drops on the Performance of Coal-Fired Thermal Power Plant. *Int. J. Ambient Energy* **2017**, *38*, 389–394. [[CrossRef](#)]
46. Dominiczak, K.; Drosińska-Komor, M.; Rządkowski, R.; Głuch, J. Optimisation of Turbine Shaft Heating Process under Steam Turbine Run-up Conditions. *Arch. Thermodyn.* **2020**, *41*, 255–268. [[CrossRef](#)]
47. Witanowski, K.; Klonowicz, P.; Lampart, P.; Suchocki, T.; Jędrzejewski, Z.; Zaniewski, D.; Klimaszewski, P. Optimization of an Axial Turbine for a Small Scale ORC Waste Heat Recovery System. *Energy* **2020**, *205*, 118059. [[CrossRef](#)]
48. Głuch, J.; Krzyżanowski, J. On Thermal Diagnostics of Turbomachinery Power Systems. In Proceedings of the 3rd European Conference on Turbomachinery: Fluid Dynamics and Thermodynamics, London, UK, 2–5 March 1999.
49. Głuch, J. Selected Problems of Determining an Efficient Operation Standard in Contemporary Heat-and-Flow Diagnostics. *Polish Marit. Res.* **2009**, *16*, 22–28. [[CrossRef](#)]
50. Macedo, L.L.; Godinho, P.; Alves, M.J. Mean-Semivariance Portfolio Optimization with Multiobjective Evolutionary Algorithms and Technical Analysis Rules. *Expert Syst. Appl.* **2017**, *79*, 33–43. [[CrossRef](#)]
51. Li, C.; Niansu, H. Fault Diagnosis for Steam-Flow Exciting Vibration of Ultra Supercritical 1000MW Steam Turbine. *Open Mech. Eng. J.* **2015**, *9*, 1067–1075. [[CrossRef](#)]
52. Kowalczyk, T.; Głuch, J.; Ziółkowski, P. Analysis of Possible Application of High-Temperature Nuclear Reactors to Contemporary Large-Output Steam Power Plants on Ships. *Polish Marit. Res.* **2016**, *23*, 32–41. [[CrossRef](#)]
53. Babykina, G.; Brinzei, N.; Aubry, J.F.; Deleuze, G. Modeling and Simulation of a Controlled Steam Generator in the Context of Dynamic Reliability Using a Stochastic Hybrid Automaton. *Reliab. Eng. Syst. Saf.* **2016**, *152*, 115–136. [[CrossRef](#)]
54. Jaskólski, M.; Reński, A.; Minkiewicz, T. Thermodynamic and Economic Analysis of Nuclear Power Unit Operating in Partial Cogeneration Mode to Produce Electricity and District Heat. *Energy* **2017**, *141*, 2470–2483. [[CrossRef](#)]
55. Breńkacz, Ł.; Kędra, R.; Janicki, W.; Maurin, A.; Bagiński, P.; Andrearczyk, A.; Zima, B. Research on Linear Actuators for Active Foil Bearings. *Materials* **2022**, *15*, 5694. [[CrossRef](#)]
56. Breńkacz, Ł. Identification of Stiffness, Damping and Mass Coefficients of Rotor-Bearing System Using Impulse Response Method. *J. Vibroeng.* **2015**, *17*, 2272–2282.
57. Breńkacz, Ł. *Bearing Dynamic Coefficients in Rotordynamics: Computation Methods and Practical Applications*; Wiley: Hoboken, NJ, USA, 2021; ISBN 9781119759287.
58. Brkovic, A.; Gajic, D.; Gligorijevic, J.; Savic-Gajic, I.; Georgieva, O.; Di Gennaro, S. Early Fault Detection and Diagnosis in Bearings for More Efficient Operation of Rotating Machinery. *Energy* **2017**, *136*, 63–71. [[CrossRef](#)]
59. Chen, Z.; He, Y.; Chu, F.; Huang, J. Evolutionary Strategy for Classification Problems and Its Application in Fault Diagnostics. *Eng. Appl. Artif. Intell.* **2003**, *16*, 31–38. [[CrossRef](#)]
60. Ma, H.; Zhao, H.; Wang, L.; Yu, Z.; Mao, X. Modeling and Investigation of a Steam-Water Injector. *Energy Convers. Manag.* **2017**, *151*, 170–178. [[CrossRef](#)]
61. Domachowski, Z. Specificity of Automatic Control of Microturbines (Steam or Gas -Driven and Expanders) in Dispersed Generation System of Heat and Electric Power. *Polish Marit. Res.* **2009**, *16*, 9–13. [[CrossRef](#)]
62. Badur, J.; Ziółkowski, P.; Sławiński, D.; Kornet, S. An Approach for Estimation of Water Wall Degradation within Pulverized-Coal Boilers. *Energy* **2015**, *92*, 142–152. [[CrossRef](#)]
63. Dzida, M. On the Possible Increasing of Efficiency of Ship Power Plant with the System Combined of Marine Diesel Engine, Gas Turbine and Steam Turbine, at the Main Engine-Steam Turbine Mode of Cooperation. *Polish Marit. Res.* **2009**, *16*, 47–52. [[CrossRef](#)]
64. Hoseyni, S.M.; Di Maio, F.; Zio, E. Condition-Based Probabilistic Safety Assessment for Maintenance Decision Making Regarding a Nuclear Power Plant Steam Generator Undergoing Multiple Degradation Mechanisms. *Reliab. Eng. Syst. Saf.* **2019**, *191*, 106583. [[CrossRef](#)]
65. Plis, M.; Rusinowski, H. A Mathematical Model of an Existing Gas-Steam Combined Heat and Power Plant for Thermal Diagnostic Systems. *Energy* **2018**, *156*, 606–619. [[CrossRef](#)]
66. Butrymowicz, D.; Głuch, J.; Hajduk, T.; Trela, M.; Gardzilewicz, A. Analysis of Fouling Thermal Resistance of Feed-Water Heaters in Steam Power Plants. *Polish Marit. Res.* **2009**, *16*, 3–8. [[CrossRef](#)]



67. Ogaji, S.; Sampath, S.; Singh, R.; Probert, D. Novel Approach for Improving Power-Plant Availability Using Advanced Engine Diagnostics. *Appl. Energy* **2002**, *72*, 389–407. [\[CrossRef\]](#)
68. Fast, M.; Palme, T. Application of Artificial Neural Networks to the Condition Monitoring and Diagnosis of a Combined Heat and Power Plant. *Energy* **2010**, *35*, 1114–1120. [\[CrossRef\]](#)
69. Zhou, D.; Yao, Q.; Wu, H.; Ma, S.; Zhang, H. Fault Diagnosis of Gas Turbine Based on Partly Interpretable Convolutional Neural Networks. *Energy* **2020**, *200*, 117467. [\[CrossRef\]](#)
70. Chang, H.H. Genetic Algorithms and Non-Intrusive Energy Management System Based Economic Dispatch for Cogeneration Units. *Energy* **2011**, *36*, 181–190. [\[CrossRef\]](#)
71. Mirhoseini, M.S.; Boroomand, M. Multi-Objective Optimization of Hot Steam Injection Variables to Control Wetness Parameters of Steam Flow within Nozzles. *Energy* **2017**, *141*, 1027–1037. [\[CrossRef\]](#)
72. Douglas, T.; Big-Alabo, A. A Generic Algorithm of Sustainability (GAS) Function for Industrial Complex Steam Turbine and Utility System Optimisation. *Energy* **2018**, *164*, 881–897. [\[CrossRef\]](#)
73. Mehrpanahi, A.; Nikbakht Naserabad, S.; Ahmadi, G. Multi-Objective Linear Regression Based Optimization of Full Repowering a Single Pressure Steam Power Plant. *Energy* **2019**, *179*, 1017–1035. [\[CrossRef\]](#)
74. Ganjehkaviri, A.; Mohd Jaafar, M.N.; Hosseini, S.E.; Barzegaravval, H. Genetic Algorithm for Optimization of Energy Systems: Solution Uniqueness, Accuracy, Pareto Convergence and Dimension Reduction. *Energy* **2017**, *119*, 167–177. [\[CrossRef\]](#)
75. Bianco, N.; Fragnito, A.; Iasiello, M.; Maria, G. A Comprehensive Approach for the Multi-Objective Optimization of Heat Recovery Steam Generators to Maximize Cost-Effectiveness and Output Power. *Sustain. Energy Technol. Assess.* **2021**, *45*, 101162. [\[CrossRef\]](#)
76. Xing, J.; Zeng, Z.; Zio, E. Joint Optimization of Safety Barriers for Enhancing Business Continuity of Nuclear Power Plants against Steam Generator Tube Ruptures Accidents. *Reliab. Eng. Syst. Saf.* **2020**, *202*, 107067. [\[CrossRef\]](#)
77. Panowski, M.; Zarzycki, R.; Kobyłecki, R. Conversion of Steam Power Plant into Cogeneration Unit-Case Study. *Energy* **2021**, *231*, 120872. [\[CrossRef\]](#)
78. Díaz-Ramírez, M.; Jokull, S.; Zuffi, C.; Mainar-Toledo, M.D.; Manfrida, G. Environmental Assessment of Hellisheidi Geothermal Power Plant Based on Exergy Allocation Factors for Heat and Electricity Production. *Energies* **2023**, *16*, 3616. [\[CrossRef\]](#)
79. Rusin, A.; Tomala, M.; Łukowicz, H.; Nowak, G.; Kosman, W. On-line Control of Stresses in the Power Unit Pressure Elements Taking Account of Variable Heat Transfer Conditions. *Energies* **2021**, *14*, 4708. [\[CrossRef\]](#)
80. Cheng, W.; Liu, X.; Xing, J.; Chen, X.; Ding, B.; Zhang, R.; Zhou, K.; Huang, Q. AFARN: Domain Adaptation for Intelligent Cross-Domain Bearing Fault Diagnosis in Nuclear Circulating Water Pump. *IEEE Trans. Ind. Inform.* **2023**, *19*, 3229–3239. [\[CrossRef\]](#)
81. Niksa-Rynkiewicz, T.; Szewczuk-Krypa, N.; Witkowska, A.; Cpałka, K.; Zalański, M.; Cader, A. Monitoring Regenerative Heat Exchanger in Steam Power Plant by Making Use of the Recurrent Neural Network. *J. Artif. Intell. Soft Comput. Res.* **2021**, *11*, 143–155. [\[CrossRef\]](#)
82. Głuch, J.; Krzyżanowski, J. New Attempt for Diagnostics of the Geometry Deterioration of the Power System Based on Thermal Measurement. In Proceedings of the ASME Turbo Expo 2006, Barcelona, Spain, 8–11 May 2006; Volume 2, pp. 531–539.
83. Ziółkowski, P.; Badur, J.; Ziółkowski, P.J. An Energetic Analysis of a Gas Turbine with Regenerative Heating Using Turbine Extraction at Intermediate Pressure-Brayton Cycle Advanced According to Szewalski's Idea. *Energy* **2019**, *185*, 763–786. [\[CrossRef\]](#)
84. Kowalczyk, T.; Badur, J.; Ziółkowski, P. Comparative Study of a Bottoming SRC and ORC for Joule–Brayton Cycle Cooling Modular HTR Exergy Losses, Fluid-Flow Machinery Main Dimensions, and Partial Loads. *Energy* **2020**, *206*, 118072. [\[CrossRef\]](#)
85. Kowalczyk, Ł.; Elsner, W.; Niegodajew, P.; Marek, M. Gradient-Free Methods Applied to Optimisation of Advanced Ultra-Supercritical Power Plant. *Appl. Therm. Eng.* **2016**, *96*, 200–208. [\[CrossRef\]](#)
86. Mikielwicz, D.; Wajs, J.; Ziółkowski, P.; Mikielwicz, J. Utilisation of Waste Heat from the Power Plant by Use of the ORC Aided with Bleed Steam and Extra Source of Heat. *Energy* **2016**, *97*, 11–19. [\[CrossRef\]](#)
87. Angerer, M.; Kahlert, S.; Spliethoff, H. Transient Simulation and Fatigue Evaluation of Fast Gas Turbine Startups and Shutdowns in a Combined Cycle Plant with an Innovative Thermal Buffer Storage. *Energy* **2017**, *130*, 246–257. [\[CrossRef\]](#)
88. Salahshoor, K.; Kordestani, M.; Khoshro, M.S. Fault Detection and Diagnosis of an Industrial Steam Turbine Using Fusion of SVM (Support Vector Machine) and ANFIS (Adaptive Neuro-Fuzzy Inference System) Classifiers. *Energy* **2010**, *35*, 5472–5482. [\[CrossRef\]](#)
89. Salahshoor, K.; Khoshro, M.S.; Kordestani, M. Fault Detection and Diagnosis of an Industrial Steam Turbine Using a Distributed Configuration of Adaptive Neuro-Fuzzy Inference Systems. *Simul. Model. Pract. Theory* **2011**, *19*, 1280–1293. [\[CrossRef\]](#)
90. Kwizdzinski, R. Experimental Investigation of Condensation Wave Structure in Steam-Water Injector. *Int. J. Heat Mass Transf.* **2015**, *91*, 594–601. [\[CrossRef\]](#)
91. Głuch, J. *The Method of Recognition of the Place and Size Degradation of Steam Power Units*; Monograph of the Gdańsk University of Technology: Gdańsk, Poland, 2007. (In Polish)
92. Głuch, J.; Drośnińska-Komor, M. Neural Modelling of Steam Turbine Control Stage. In *Advances in Diagnostics of Processes and Systems. Studies in Systems, Decision and Control*; Springer: Berlin/Heidelberg, Germany, 2021; pp. 117–128. ISBN 9783030589646.
93. Santosh, T.V.; Vinod, G.; Saraf, R.K.; Ghosh, A.K.; Kushwaha, H.S. Application of Artificial Neural Networks to Nuclear Power Plant Transient Diagnosis. *Reliab. Eng. Syst. Saf.* **2007**, *92*, 1468–1472. [\[CrossRef\]](#)

94. Butterweck, A.; Gluch, J. Neural Network Simulator's Application to Reference Performance Determination of Turbine Blading in the Heat-Flow Diagnostics. In *Intelligent Systems in Technical and Medical Diagnostics*; Springer: Berlin/Heidelberg, Germany, 2014; pp. 137–147.
95. Gluch, J. Application of Artificial Neural Networks (ANN) as Multiple Degradation Classifiers in Thermal and Flow Diagnostics. *TASK Q.* **2005**, *9*, 199–210.
96. Kuo, R.J. Intelligent Diagnosis for Turbine Blade Faults Using Artificial Neural Networks and Fuzzy Logic. *Eng. Appl. Artif. Intell.* **1995**, *8*, 25–34. [[CrossRef](#)]
97. Madejski, P.; Żymelka, P. Calculation Methods of Steam Boiler Operation Factors under Varying Operating Conditions with the Use of Computational Thermodynamic Modeling. *Energy* **2020**, *197*, 117221. [[CrossRef](#)]
98. Kruk-Gotzman, S.; Ziółkowski, P.; Iliev, I.; Negreanu, G.-P.; Badur, J. Techno-Economic Evaluation of Combined Cycle Gas Turbine and a Diabatic Compressed Air Energy Storage Integration Concept. *Energy* **2023**, *266*, 126345. [[CrossRef](#)]
99. Yan, C.; Zhang, H.; Wu, L. A Novel Real-Time Fault Diagnostic System by Using Strata Hierarchical Artificial Neural Network. In Proceedings of the 2009 Asia-Pacific Power and Energy Engineering Conference, Wuhan, China, 27–31 March 2009; pp. 1–4.
100. Ślęzak-Żołna, J. On the Application of the Artificial Neural Network Method to a Neural Simulator of Steam Turbine Power Plant. *Polish Marit. Res.* **2006**, *1*, 16–20.
101. Gardzilewicz, A.; Gluch, J.; Bogulicz, M.; Walkowiak, R.; Najwer, M.; Kiebdaj, J. Experience in Application of Thermal Diagnostics in the Turow Power Station. In Proceedings of the International Joint Power Generation Conference, Atlanta, GA, USA, 16–19 June 2003.
102. Nowak, G.; Rusin, A. Using the Artificial Neural Network to Control the Steam Turbine Heating Process. *Appl. Therm. Eng.* **2016**, *108*, 204–210. [[CrossRef](#)]
103. Barelli, L.; Bidini, G.; Bonucci, F. Diagnosis of a Turbocharging System of 1 MW Internal Combustion Engine. *Energy Convers. Manag.* **2013**, *68*, 28–39. [[CrossRef](#)]
104. Liu, Z.; Karimi, I.A. Simulating Combined Cycle Gas Turbine Power Plants in Aspen HYSYS. *Energy Convers. Manag.* **2018**, *171*, 1213–1225. [[CrossRef](#)]
105. Zhou, D.; Zhang, H.; Weng, S. A New Gas Path Fault Diagnostic Method of Gas Turbine Based on Support Vector Machine. *J. Eng. Gas Turbines Power* **2015**, *137*, 102605. [[CrossRef](#)]
106. Wong, P.K.; Yang, Z.; Vong, C.M.; Zhong, J. Real-Time Fault Diagnosis for Gas Turbine Generator Systems Using Extreme Learning Machine. *Neurocomputing* **2014**, *128*, 249–257. [[CrossRef](#)]
107. Tsoutsanis, E.; Meskin, N.; Benammar, M.; Khorasani, K. Transient Gas Turbine Performance Diagnostics Through Nonlinear Adaptation of Compressor and Turbine Maps. *J. Eng. Gas Turbines Power* **2015**, *137*, 091201. [[CrossRef](#)]
108. Tsoutsanis, E.; Meskin, N.; Benammar, M.; Khorasani, K. A Dynamic Prognosis Scheme for Flexible Operation of Gas Turbines. *Appl. Energy* **2016**, *164*, 686–701. [[CrossRef](#)]
109. Barad, S.G.; Ramaiah, P.V.; Giridhar, R.K.; Krishnaiah, G. Neural Network Approach for a Combined Performance and Mechanical Health Monitoring of a Gas Turbine Engine. *Mech. Syst. Signal Process.* **2012**, *27*, 729–742. [[CrossRef](#)]
110. Madhavan, S.; Jain, R.; Sujatha, C.; Sekhar, A.S. Vibration Based Damage Detection of Rotor Blades in a Gas Turbine Engine. *Eng. Fail. Anal.* **2014**, *46*, 26–39. [[CrossRef](#)]
111. Aslanidou, I.; Rahman, M.; Zaccaria, V.; Kyprianidis, K.G. Micro Gas Turbines in the Future Smart Energy System: Fleet Monitoring, Diagnostics, and System Level Requirements. *Front. Mech. Eng.* **2021**, *7*, 676853. [[CrossRef](#)]
112. Sławiński, D.; Ziółkowski, P.; Badur, J. Thermal Failure of a Second Rotor Stage in Heavy Duty Gas Turbine. *Eng. Fail. Anal.* **2020**, *115*, 104672. [[CrossRef](#)]
113. Ślęzak-Żołna, J.; Gluch, J. *Towards Symptoms of Degradation in On-Line Thermal and Flow Diagnostics of Power Objects*; IFAC: Yokohama, Japan, 2006; Volume 6, ISBN 9783902661142.
114. Butterweck, A.; Gluch, J. Accuracy Investigations of Turbine Blading Neural Models Applied to Thermal and Flow Diagnostics. In *Advanced and Intelligent Computations in Diagnosis and Control*; Springer: Berlin/Heidelberg, Germany, 2016; pp. 267–274. ISBN 9783319231808.
115. Angelakis, C.; Loukis, E.; Pouliezios, A.; Starvrakakis, G. A Neural Network-Based Method for Gas Turbine Blading Fault Diagnosis. *Int. J. Model. Simul.* **2001**, *21*, 51–60. [[CrossRef](#)]
116. Aretakis, N.; Mathioudakis, K. Wavelet Analysis for Gas Turbine Fault Diagnostics. *Am. Soc. Mech. Eng.* **1996**, *119*, 870–876.
117. Li, Y.G.; Nilkitsaranont, P. Gas Turbine Performance Prognostic for Condition-Based Maintenance. *Appl. Energy* **2009**, *86*, 2152–2161. [[CrossRef](#)]
118. Breikin, T.V.; Kulikov, G.G.; Arkov, V.Y.; Fleming, P.J. *Dynamic Modelling for Condition Monitoring of Gas Turbines: Genetic Algorithms Approach*; IFAC: Yokohama, Japan, 2005; Volume 38, ISBN 008045108X.
119. Fentaye, A.; Zaccaria, V.; Rahman, M.; Stenfelt, M.; Kyprianidis, K. Hybrid Model-Based and Data-Driven Diagnostic Algorithm for Gas Turbine Engines. In Proceedings of the ASME Turbo Expo 2020: Turbomachinery Technical Conference and Exposition, Online, 21–25 September 2020; Volume 9, p. 6.
120. Dhini, A.; Surjandari, I.; Kusumoputro, B.; Kusiak, A. Extreme Learning Machine–Radial Basis Function (ELM-RBF) Networks for Diagnosing Faults in a Steam Turbine. *J. Ind. Prod. Eng.* **2021**, *39*, 572–580. [[CrossRef](#)]

121. Yang, N.; Zhang, G.; Wang, J. Research on Knowledge Graph and Bayesian Network in Fault Diagnosis of Steam Turbine. In Proceedings of the 2020 Global Reliability and Prognostics and Health Management (PHM-Shanghai), Shanghai, China, 16–18 October 2020; pp. 1–6.
122. Zeng, D.; Zhou, D.; Tan, C.; Jiang, B. Research on Model-Based Fault Diagnosis for a Gas Turbine Based on Transient Performance. *Appl. Sci.* **2018**, *8*, 148. [[CrossRef](#)]
123. Salilew, W.M.; Abdul Karim, Z.A.; Lemma, T.A.; Fentaye, A.D.; Kyprianidis, K.G. The Effect of Physical Faults on a Three-Shaft Gas Turbine Performance at Full- and Part-Load Operation. *Sensors* **2022**, *22*, 7150. [[CrossRef](#)]
124. Yang, Q.; Li, S.; Cao, Y. A Strong Tracking Filtering Approach for Health Estimation of Marine Gas Turbine Engine. *J. Mar. Sci. Appl.* **2019**, *18*, 542–553. [[CrossRef](#)]
125. Asgari, H.; Chen, X.; Menhaj, M.B.; Sainudiin, R. Artificial Neural Network-Based System Identification for a Single-Shaft Gas Turbine. *J. Eng. Gas Turbines Power* **2013**, *135*, 092601. [[CrossRef](#)]
126. Mo, E.J.; Jie, M.S.; Kim, C.S.; Lee, K.W. Fault Diagnosis in Gas Turbine Engine Using Fuzzy Inference Logic. *J. Inst. Control. Robot. Syst.* **2008**, *14*, 49–53.
127. Zhang, D.; Wang, L.; Hong, Q.; Zhang, K. Research on Fault Diagnosis of Steam Turbine Based on Bayesian Network. *J. Phys. Conf. Ser.* **2021**, *1754*, 012136. [[CrossRef](#)]
128. Chmielniak, T.; Trela, M. *Diagnostics of New-Generation Thermal Power Plants*; Wydawnictwo IMP PAN: Gdansk, Poland, 2008; ISBN 978-83-88237-31-7.
129. Bzymek, G.; Badur, J.; Ziółkowski, P. Issues to Improve the Safety of 18K370 Steam Turbine Operation. *E3S Web Conf.* **2017**, *13*, 04003. [[CrossRef](#)]
130. Banaszkiwicz, M. On-Line Monitoring and Control of Thermal Stresses in Steam Turbine Rotors. *Appl. Therm. Eng.* **2016**, *94*, 763–776. [[CrossRef](#)]
131. Banaszkiwicz, M. Multilevel Approach to Lifetime Assessment of Steam Turbines. *Int. J. Fatigue* **2015**, *73*, 39–47. [[CrossRef](#)]
132. Banaszkiwicz, M.; Rehmus-Forc, A. Stress Corrosion Cracking of a 60 MW Steam Turbine Rotor. *Eng. Fail. Anal.* **2015**, *51*, 55–68. [[CrossRef](#)]
133. Kraszewski, B.; Bzymek, G.; Ziółkowski, P.; Badur, J. Extremal Thermal Loading of a Bifurcation Pipe. *AIP Conf. Proc.* **2019**, *2077*, 020030. [[CrossRef](#)]
134. Badur, J.; Kornet, S.; Sławiński, D.; Ziółkowski, P. Analysis of Unsteady Flow Forces Acting on the Thermowell in a Steam Turbine Control Stage. *J. Phys. Conf. Ser.* **2016**, *760*, 012001. [[CrossRef](#)]
135. Badur, J.; Ziolkowski, P.; Kornet, S.; Stajnje, M.; Bryk, M.; Banas, K.; Ziolkowski, P. The Effort of the Steam Turbine Caused by a Flood Wave Load. *AIP Conf. Proc.* **2017**, *1822*, 020001.
136. Madejski, P.; Taler, D.; Taler, J. Numerical Model of a Steam Superheater with a Complex Shape of the Tube Cross Section Using Control Volume Based Finite Element Method. *Energy Convers. Manag.* **2016**, *118*, 179–192. [[CrossRef](#)]
137. Blaut, J.; Breńkacz, Ł. Application of the Teager-Kaiser Energy Operator in Diagnostics of a Hydrodynamic Bearing. *Eksploat. I Niezawodn.* **2020**, *22*, 757–765. [[CrossRef](#)]
138. Andrearczyk, A.; Zywica, G.; Brenkacz, L.; Baginski, P. Vibration Based Diagnostics of the Multi-Stage Microturbine Operating in the Medium-temperature ORC System. *Vibroeng. Procedia* **2017**, *13*, 56–61. [[CrossRef](#)]
139. Badur, J.; Ziółkowski, P.; Zakrzewski, W.; Sławiński, D.; Kornet, S.; Kowalczyk, T.; Hernet, J.; Piotrowski, R.; Felincjancik, J.; Ziółkowski, P.J. An Advanced Thermal-FSI Approach to Flow Heating/Cooling. *J. Phys. Conf. Ser.* **2014**, *530*, 012039. [[CrossRef](#)]
140. Ziółkowski, P.; Kowalczyk, T.; Lemański, M.; Badur, J. On Energy, Exergy, and Environmental Aspects of a Combined Gas-Steam Cycle for Heat and Power Generation Undergoing a Process of Retrofitting by Steam Injection. *Energy Convers. Manag.* **2019**, *192*, 374–384. [[CrossRef](#)]
141. Ziółkowski, P.; Kowalczyk, T.; Kornet, S.; Badur, J. On Low-Grade Waste Heat Utilization from a Supercritical Steam Power Plant Using an ORC-Bottoming Cycle Coupled with Two Sources of Heat. *Energy Convers. Manag.* **2017**, *146*, 158–173. [[CrossRef](#)]
142. Ziółkowski, P.; Szewczuk-Krypa, N.; Butterweck, A.; Stajnje, M.; Głuch, S.; Drosińska-Komor, M.; Milewska, A.; Głuch, J. Comprehensive Thermodynamic Analysis of Steam Storage in a Steam Cycle in a Different Regime of Work: A Zero-Dimensional and Three-Dimensional Approach. *J. Energy Resour. Technol.* **2021**, *143*, 050905. [[CrossRef](#)]
143. Lampart, P.; Witanowski, Ł.; Klonowicz, P. Efficiency Optimisation of Blade Shape in Steam and ORC Turbines. *Mech. Mech. Eng.* **2018**, *22*, 553–564. [[CrossRef](#)]
144. Niksa-Rynkiewicz, T.; Witkowska, A.; Głuch, J.; Adamowicz, M. Monitoring the Gas Turbine Start-Up Phase on a Platform Using a Hierarchical Model Based on Multi-Layer Perceptron Networks. *Polish Marit. Res.* **2022**, *29*, 123–131. [[CrossRef](#)]
145. Korczewski, Z. Exhaust Gas Temperature Measurements in Diagnostic Examination of Naval Gas Turbine Engines. *Polish Marit. Res.* **2011**, *18*, 49–53. [[CrossRef](#)]
146. Ziółkowski, P.; Hyrzyński, R.; Lemański, M.; Kraszewski, B.; Bykuć, S.; Głuch, S.; Sowizdzał, A.; Pająk, L.; Wachowicz-Pyzik, A.; Badur, J. Different Design Aspects of an Organic Rankine Cycle Turbine for Electricity Production Using a Geothermal Binary Power Plant. *Energy Convers. Manag.* **2021**, *246*, 114672. [[CrossRef](#)]
147. Witanowski, Ł.; Breńkacz, Ł.; Szewczuk-Krypa, N.; Dorosińska-Komor, M.; Puchalski, B. Comparable Analysis of PID Controller Settings in Order to Ensure Reliable Operation of Active Foil Bearings. *Eksploat. I Niezawodn.-Maint. Reliab.* **2022**, *24*, 377–385. [[CrossRef](#)]
148. Golberg, D.E. *Genetic Algorithms in Search Optimization & Machine Learning*; Addison-Westly: Reading, MA, USA, 1989; 432p.



149. Longhi, A.E.B.; Pessoa, A.A.; Garcia, P.A.D.A. Multiobjective Optimization of Strategies for Operation and Testing of Low-Demand Safety Instrumented Systems Using a Genetic Algorithm and Fault Trees. *Reliab. Eng. Syst. Saf.* **2015**, *142*, 525–538. [[CrossRef](#)]
150. Volkanovski, A.; Mavko, B.; Boševski, T.; Čauševski, A.; Čepin, M. Genetic Algorithm Optimisation of the Maintenance Scheduling of Generating Units in a Power System. *Reliab. Eng. Syst. Saf.* **2008**, *93*, 779–789. [[CrossRef](#)]
151. Gjorgiev, B.; Čepin, M. A Multi-Objective Optimization Based Solution for the Combined Economic-Environmental Power Dispatch Problem. *Eng. Appl. Artif. Intell.* **2013**, *26*, 417–429. [[CrossRef](#)]
152. Kim, W.; Jeon, S.W.; Kim, Y. Model-Based Multi-Objective Optimal Control of a VRF (Variable Refrigerant Flow) Combined System with DOAS (Dedicated Outdoor Air System) Using Genetic Algorithm under Heating Conditions. *Energy* **2016**, *107*, 196–204. [[CrossRef](#)]
153. Iyer, V.H.; Mahesh, S.; Malpani, R.; Sapre, M.; Kulkarni, A.J. Adaptive Range Genetic Algorithm: A Hybrid Optimization Approach and Its Application in the Design and Economic Optimization of Shell-and-Tube Heat Exchanger. *Eng. Appl. Artif. Intell.* **2019**, *85*, 444–461. [[CrossRef](#)]
154. Millo, F.; Arya, P.; Mallamo, F. Optimization of Automotive Diesel Engine Calibration Using Genetic Algorithm Techniques. *Energy* **2018**, *158*, 807–819. [[CrossRef](#)]
155. Postolov, B.; Hinov, N.; Iliev, A.; Dimitrov, D. Short-Term Hydro-Thermal-Solar Scheduling with CCGT Based on Self-Adaptive Genetic Algorithm. *Energies* **2022**, *15*, 5989. [[CrossRef](#)]
156. Arabas, J. Approximating the Genetic Diversity of Populations in the Quasi-Equilibrium State. *IEEE Trans. Evol. Comput.* **2012**, *16*, 632–644. [[CrossRef](#)]
157. Srinivasan, D.; Cheu, R.L.; Poh, Y.P.; Ng, A.K.C. Automated Fault Detection in Power Distribution Networks Using a Hybrid Fuzzy-Genetic Algorithm Approach. *Eng. Appl. Artif. Intell.* **2000**, *13*, 407–418. [[CrossRef](#)]
158. Alsuwian, T.; Tayyeb, M.; Amin, A.A.; Qadir, M.B.; Almasabi, S.; Jalalah, M. Design of a Hybrid Fault-Tolerant Control System for Air-Fuel Ratio Control of Internal Combustion Engines Using Genetic Algorithm and Higher-Order Sliding Mode Control. *Energies* **2022**, *15*, 5666. [[CrossRef](#)]
159. Kim, H.; Kim, P. Reliability-Redundancy Allocation Problem Considering Optimal Redundancy Strategy Using Parallel Genetic Algorithm. *Reliab. Eng. Syst. Saf.* **2017**, *159*, 153–160. [[CrossRef](#)]
160. Cheung, B.C.; Carriveau, R.; Ting, D.S.K. Multi-Objective Optimization of an Underwater Compressed Air Energy Storage System Using Genetic Algorithm. *Energy* **2014**, *74*, 396–404. [[CrossRef](#)]
161. Wan, A.; Chang, Q.; Zhang, Y.; Wei, C.; Agbozo, R.S.K.; Zhao, X. Optimal Load Distribution of CHP Based on Combined Deep Learning and Genetic Algorithm. *Energies* **2022**, *15*, 7736. [[CrossRef](#)]
162. Tao, J.; Wang, H.; Wang, J.; Feng, C. Exergoeconomic and Exergoenvironmental Analysis of a Novel Power and Cooling Cogeneration System Based on Organic Rankine Cycle and Ejector Refrigeration Cycle. *Energies* **2022**, *15*, 7945. [[CrossRef](#)]
163. Zemliak, A. A Modified Genetic Algorithm for System Optimization. *COMPEL-Int. J. Comput. Math. Electr. Electron. Eng.* **2022**, *41*, 499–516. [[CrossRef](#)]
164. Hichri, A.; Hajji, M.; Mansouri, M.; Abodayeh, K.; Bouzrara, K.; Nounou, H.; Nounou, M. Genetic-Algorithm-Based Neural Network for Fault Detection and Diagnosis: Application to Grid-Connected Photovoltaic Systems. *Sustainability* **2022**, *14*, 10518. [[CrossRef](#)]
165. Kumar, G.N.; Gundabattini, E. Investigation of Supercritical Power Plant Boiler Combustion Process Optimization through CFD and Genetic Algorithm Methods. *Energies* **2022**, *15*, 9076. [[CrossRef](#)]
166. El Makroum, R.; Khallaayoun, A.; Lghoul, R.; Mehta, K.; Zörner, W. Home Energy Management System Based on Genetic Algorithm for Load Scheduling: A Case Study Based on Real Life Consumption Data. *Energies* **2023**, *16*, 2698. [[CrossRef](#)]
167. Xu, W.; Sun, H.Y.; Awaga, A.L.; Yan, Y.; Cui, Y.J. Optimization Approaches for Solving Production Scheduling Problem: A Brief Overview and a Case Study for Hybrid Flow Shop Using Genetic Algorithms. *Adv. Prod. Eng. Manag.* **2022**, *17*, 45–56. [[CrossRef](#)]
168. Agarwal, M.; Gupta, S.K.; Biswas, K.K. Genetic Algorithm Based Approach to Compress and Accelerate the Trained Convolution Neural Network Model. *Int. J. Mach. Learn. Cybern.* **2023**, *14*, 2367–2383. [[CrossRef](#)]
169. Deng, W.; Zhang, X.; Zhou, Y.; Liu, Y.; Zhou, X.; Chen, H.; Zhao, H. An Enhanced Fast Non-Dominated Solution Sorting Genetic Algorithm for Multi-Objective Problems. *Inf. Sci.* **2022**, *585*, 441–453. [[CrossRef](#)]
170. Al-qaysi, A.M.M.; Bozkurt, A. Network-Adaptive Neuro-Fuzzy Inference Systems: A Case Study in Iraq. *Energies* **2023**, *16*, 2919. [[CrossRef](#)]
171. Izonin, I.; Tkachenko, R. An Approach towards the Response Surface Linearization via ANN-Based Cascade Scheme for Regression Modeling in Healthcare. *Procedia Comput. Sci.* **2022**, *198*, 724–729. [[CrossRef](#)]
172. Feng, L.; Zhang, L. Enhanced Prediction Intervals of Tunnel-Induced Settlement Using the Genetic Algorithm and Neural Network. *Reliab. Eng. Syst. Saf.* **2022**, *223*, 108439. [[CrossRef](#)]
173. Szczepaniuk, H.; Szczepaniuk, E.K. Applications of Artificial Intelligence Algorithms in the Energy Sector. *Energies* **2022**, *16*, 347. [[CrossRef](#)]
174. Witkowska, A.; Rynkiewicz, T.N. Dynamically Positioned Ship Steering Making Use of Backstepping Method and Artificial Neural Networks. *Polish Marit. Res.* **2018**, *25*, 5–12. [[CrossRef](#)]
175. Gülcü, Ş. Training of the Feed Forward Artificial Neural Networks Using Dragonfly Algorithm[Formula Presented]. *Appl. Soft Comput.* **2022**, *124*, 109023. [[CrossRef](#)]

176. Unnisa, A.N.; Yerva, M.; Kurian, M.Z. Review on Intrusion Detection System (IDS) for Network Security Using Machine Learning Algorithms. *Int. Res. J. Adv. Sci. Hub* **2022**, *4*, 67–74. [[CrossRef](#)]
177. Kudełko, M. Modeling of Polish Energy Sector—Tool Specification and Results. *Energy* **2021**, *215*, 119149. [[CrossRef](#)]
178. Zeyghami, M. Performance Analysis and Binary Working Fluid Selection of Combined Flash-Binary Geothermal Cycle. *Energy* **2015**, *88*, 765–774. [[CrossRef](#)]
179. Steinmann, W.D.; Eck, M. Buffer Storage for Direct Steam Generation. *Sol. Energy* **2006**, *80*, 1277–1282. [[CrossRef](#)]
180. Hyrzyński, R.; Ziółkowski, P.; Gotzman, S.; Kraszewski, B.; Badur, J. Thermodynamic Analysis of the Compressed Air Energy Storage System Coupled with the Underground Thermal Energy Storage. *E3S Web Conf.* **2019**, *137*, 01023. [[CrossRef](#)]
181. Krzyżanowski, J.; Krzyślak, P.; Głuch, J. On Application of Statistics to Verification of Turbomachinery Calculation Methods. In Proceedings of the ASME 1992 International Gas Turbine and Aeroengine Congress and Exposition, Cologne, Germany, 1–4 June 1992; Volume 1. [[CrossRef](#)]
182. Drosińska-Komor, M.; Głuch, J. Istotność Procesu Selekcji Przy Wykorzystaniu Algorytmów Genetycznych Do Diagnostyki Ciepłno-Przepływowej. *Przegląd Mech.* **2018**, *9*, 55–57. [[CrossRef](#)]
183. Drosińska-Komor, M. Metoda Diagnostyki Ciepłno-Przepływowej Turbin Parowych Wykorzystująca Elementy Algorytmów Genetycznych. Ph.D. Thesis, Politechnika Gdańska, Wydział Inżynierii Mechanicznej i Okrętownictwa, Gdańsk, Poland, 2023.
184. Vishwajeet; Pawlak-Kruczek, H.; Baranowski, M.; Czerep, M.; Chorążyczewski, A.; Krochmalny, K.; Ostrycharczyk, M.; Ziółkowski, P.; Madejski, P.; Mączka, T.; et al. Entrained Flow Plasma Gasification of Sewage Sludge— Proof-of-Concept and Fate of Inorganics. *Energies* **2022**, *15*, 1948. [[CrossRef](#)]
185. Brachi, P.; Di Fraia, S.; Massarotti, N.; Vanoli, L. Combined Heat and Power Production Based on Sewage Sludge Gasification: An Energy-Efficient Solution for Wastewater Treatment Plants. *Energy Convers. Manag. X* **2022**, *13*, 100171. [[CrossRef](#)]
186. Ziółkowski, P.; Madejski, P.; Amiri, M.; Kuś, T.; Stasiak, K.; Subramanian, N.; Pawlak-Kruczek, H.; Badur, J.; Niedźwiecki, Ł.; Mikielewicz, D. Thermodynamic Analysis of Negative CO<sub>2</sub> Emission Power Plant Using Aspen Plus, Aspen Hysys, and Ebsilon Software. *Energie* **2021**, *14*, 6304. [[CrossRef](#)]
187. Ertesvåg, I.S.; Madejski, P.; Ziółkowski, P.; Mikielewicz, D. Exergy Analysis of a Negative CO<sub>2</sub> Emission Gas Power Plant Based on Water Oxy-Combustion of Syngas from Sewage Sludge Gasification and CCS. *Energy* **2023**, *278*, 127690. [[CrossRef](#)]
188. Witanowski, Ł.; Klonowicz, P.; Lampart, P.; Ziółkowski, P. Multi-Objective Optimization of the ORC Axial Turbine for a Waste Heat Recovery System Working in Two Modes: Cogeneration and Condensation. *Energy* **2023**, *264*, 126187. [[CrossRef](#)]
189. Wachowicz-Pyzik, A.; Sowizdzał, A.; Pająk, L.; Ziółkowski, P.; Badur, J. Assessment of the Effective Variants Leading to Higher Efficiency for the Geothermal Doublet, Using Numerical Analysis—Case Study from Poland (Szczecin Trough). *Energies* **2020**, *13*, 2174. [[CrossRef](#)]
190. Yang, X.; Wang, X.; Liu, Z.; Luo, X.; Yan, J. Effect of Fin Number on the Melting Phase Change in a Horizontal Finned Shell-and-Tube Thermal Energy Storage Unit. *Sol. Energy Mater. Sol. Cells* **2022**, *236*, 111527. [[CrossRef](#)]
191. Kotowicz, J.; Węcel, D.; Kwilinski, A.; Brzęczek, M. Efficiency of the Power-to-Gas-to-Liquid-to-Power System Based on Green Methanol. *Appl. Energy* **2022**, *314*, 118933. [[CrossRef](#)]

**Disclaimer/Publisher's Note:** The statements, opinions and data contained in all publications are solely those of the individual author(s) and contributor(s) and not of MDPI and/or the editor(s). MDPI and/or the editor(s) disclaim responsibility for any injury to people or property resulting from any ideas, methods, instructions or products referred to in the content.