

TOWARD SAFE AND EFFICIENT RECOVERY OF GAS MUNITIONS DUMPED AT SEA

Lech Rowiński* 

Gdansk University of Technology, Institute of Naval Architecture, Poland

Thanh Hai Truong

Phuoc Quy Phong Nguyen

PATET Research Group, Ho Chi Minh City University of Transport, Ho Chi Minh City, Viet Nam

Corresponding author: lech.rowinski@pg.edu.pl (Lech Rowiński)

ABSTRACT

The proposal of a system for the safe recovery of unexploded ordnance (UXO), chemical weapons (CW) and chemical warfare agents (CWA) dumped at sea mainly after WWI and WWII is described in this work. The proposed solution addresses the tasks required to neutralise thousands of tons of dumped material and the currently available solutions and proposed ideas. Requirements concerning the features of a recovery system are defined and scrutinised, these being intended to ensure the safety of this phase of the UXO/CW neutralisation process. To meet this requirement, the concept of a remotely operated, two-component working size underwater vehicle is proposed, supplemented by a properly sized and outfitted surface platform that is an important part of the recovery system. Finally, the basic components of the proposed system configuration are characterised, together with their functions during the recovery of dangerous CWA-related objects.

Keywords: remotely operated robot vehicle, chemical warfare agent, unexploded ordnance disposal

INTRODUCTION

Seen from a land based perspective, the marine environment seems to be endless in three dimensions and perfectly sustainable. The appearance of a water body at any instant depends on the weather, but ultimately the waves or a calm water surface seem always to be the same and self-healing. This is the reason why people have considered the ocean as both an unlimited source of wealth and an unlimited sink for all anthropogenic wastes. However, within the ocean, one kind of such waste is unused and unexploded munitions. This includes munitions (chemical

weapons – CW) filled with chemical warfare agents (CWAs) of various kinds and containers filled with unused CWAs. According to Beldowski [1], there are roughly 150 to 300 sites worldwide with dumped chemical weapons. That number includes around 50 sites along the American coastlines, with a significant proportion in Hawaii. The total amount is unknown but a group of researchers from the Middlebury Institute of International Studies in Monterey, California, calculated that the total amount of chemical munitions in known locations amounts to 1.6 million tons, while roughly the same amount has been dumped elsewhere [2], and the identified sites can be seen on an interactive map [3]. The

most comprehensive description of the current knowledge of Baltic Sea dumping sites, which includes the characterisation of threats, is published by HELCOM (<https://helcom.fi/>) [4].

When first dumped, CW devices containing chemical warfare agents (CWAs) posed no direct, large-scale threat to people or the marine environment. They were contained in sealed shells and were not provided with detonators. Sometimes the dumped CWs contain bursting and priming charges, but, as far as is known, there have been no explosions during actions to find chemical warfare bombs in the Baltic [5]. However, during the dumping operations some containers were damaged and released poisonous chemicals to the environment. This resulted in several fatal accidents during the first few decades after WW II. With time, people learned how to avoid such hazards. However, bomb shells and CWA containers were usually made of thin sheets of iron alloys, and due to corrosion processes they have now often completely faded away. The remaining semi-solidified mustard gas lumps often contain both priming and bursting charges, as shown in **Fig. 1**.

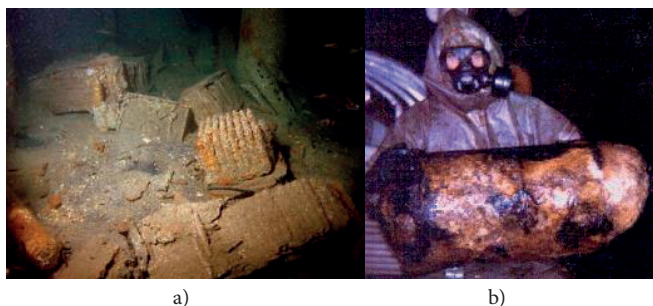

Fig. 1. Possible material forms of dumped CW devices and CWA: (a) Camera image of the sea bottom at a dumping site; (b) Semi-solid lump of mustard gas reflecting the shape of a gas-filled aerial bomb after its casing corroded completely [5][6]

A number of solutions have been proposed for some of the components of recovery and transportation tasks. One of the most serious recent proposals is the concept of a munition neutralisation barge to be operated in the Baltic and other areas (). This concept was developed by the Remontowa Group (Poland) based on the experience and solutions of the modular disposal line from Dynasafe Demil Systems AB [12][13][14]. The concept involves a double hull platform with a length of 105 m and width of 24 m. Manned with 40 persons, the facility would be capable of disposing of approximately 1250 kg of ammunition per day. This seems a substantial amount, but the neutralisation of 100,000 tons would take a single installation some 300 years to accomplish. This means that, in practice, only the most dangerous (threatening) dumping sites can be cleared. The concept prepared by the Remontowa - Dynasafe consortium demonstrates an understanding of the seriousness of the undertaking, indicating the approximate dimensions of the hypothetical surface platform required for operation with the neutralisation facility located at the dumping site. The solution apparently eliminates problems with the long-range transportation of the recovered CWs, but does not answer the question of how to safely recover and transfer

them to the neutralisation barge. Their proposal “to pre-load (simply) the ammunition into the recovery containers while still underwater and prepare the underwater cache for collection by groups of navy divers-miners and specialist diving service providers” seems unrealistic. However, the consortium indicates the requirement for an increase in capacity, “through the provision of specialist robots and heavy suits, which eliminate the diver’s contact with the external environment and hazardous substances” [13]. Less practically developed ideas can be found in some descriptions of patents and patents pending. The US4621562A patent proposes the application of a wheeled manipulator to handle dumped UXO, as shown in **Fig. 2a** [15]. This is a remotely controlled robot vehicle that includes at least two pairs of wheels, at least one pair of which is driven, the said pairs of wheels being mounted on a support secured to the vehicle, whose supports are each mounted for pivotal movement about a generally horizontal axis extending longitudinally from the vehicle, with the wheels on the same side of the vehicle being capable of being driven synchronously. The vehicle carries a manipulation arm with a claw that allows for the handling of dumped shells. Another bottom-positioned device is described in the US7363844 B2 patent and concerns a remotely operated underwater non-destructive ordnance recovery system, which includes a powered remote controller, a floating remote-controlled transceiver wired to a remote disposal unit having a hydraulic grapple, and an ordnance recovery basket, together with the method by which these devices are used to extract unexploded underwater ordnance, as depicted in **Fig. 2b** [16]. The remote disposal unit includes an electrically driven internal hydraulic pump with bio-degradable hydraulic fluid in a closed loop system. A base includes variable footplates to stabilise the hydraulic grapple by remotely adjustable telescoping legs. A control head that receives signals from control cables and transfers them into hydraulic valve actuation, an extendable fully rotating boom, two ballast tubes, a rotating grapple, and illuminated underwater cameras on the control box and ballast tubes are also included in the remote disposal unit.

Moreover, the objective of an invention described in EP3479052B1 is to create a method and a corresponding device to quite significantly reduce the harm to humans and the environment and is described non-exhaustively below by way of an example in the course of clearing UXO while avoiding any detonation underwater, as shown in **Fig. 3a** [17]. The object is reached according to the invention first exposed, and excavated sufficiently to permit its identification. In a second step, the UXO is separated from the surrounding seawater by placing it into a closable chamber, which is emptied of seawater once closed. Then, the casing of the UXO is cut open by means of water jet cutting. A device described in patent WO2020030558A1 is also suspended from the surface. This patent relates to an apparatus and a method for deactivating unexploded ordnance located underwater having at least one fuse, as illustrated in **Fig. 3b** [18], in which the apparatus (1) comprises a housing (2) that can be closed under water and from which water can be removed, a holder (4) for receiving the unexploded ordnance (5), the holder

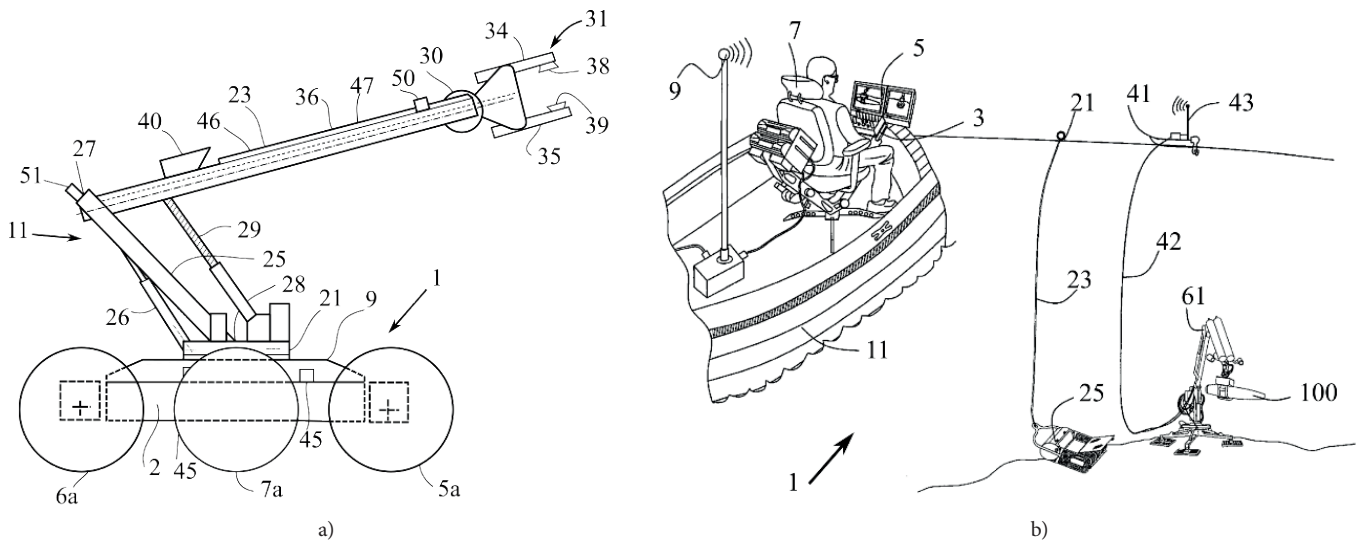

Fig. 2. Proposals of bottom equipment for remotely operated recovery of water-dumped unexploded munitions:
 (a) Bottom driving wheeled munition lifting robot according to US4621562A patent [15];
 (b) Remotely operated UXO recovery system composed of bottom located manipulator and separate lifting device US7363844 B2 [16]

being fixed in position in the housing (2), location means for precisely determining the location of the fuse (8) of the unexploded ordnance (5), a manipulator (10) having cutting means, and a gripper for removing and isolating the fuse (8) once cut free from the rest of the unexploded ordnance (5).

The invention is intended for sea mines and other ordnance filled with explosives, and provides that the UXO will be cut to pieces underwater by the device itself. However, it is rather unsuitable for direct use on chemical weapons.

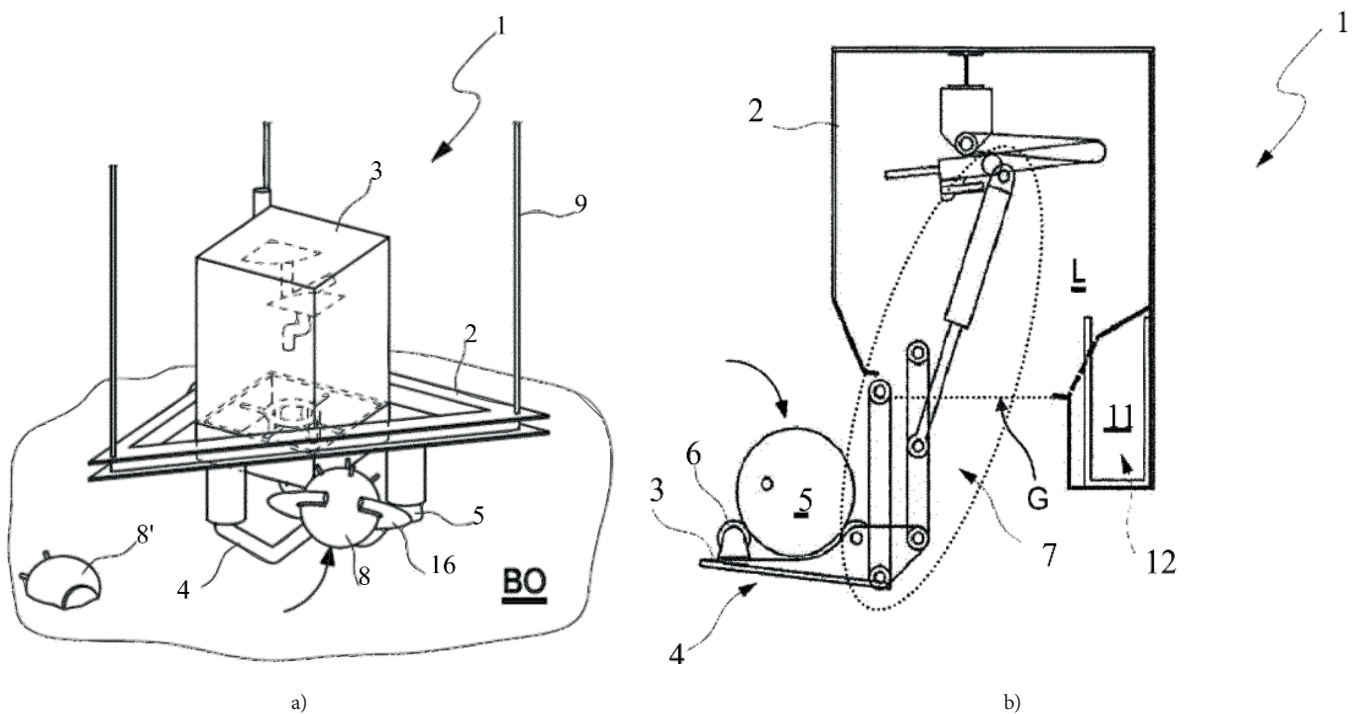

Fig. 3. UXO recovery devices suspended from surface platforms: (a) UXO recovery using device suspended from surface autonomous platform according to EP3479052B1 [17]; (b) UXO recovery using device suspended from surface autonomous platform according to WO2020030558A1 [18]

PROCESS OF NEUTRALISATION OF GAS MUNITIONS

The process of neutralisation of sea-dumped CWs is composed of four basic phases:

1. Investigation of the suspected site and identification of local threats;
2. Handling and recovery of the identified object to the surface;
3. Transport to recover the object to a neutralisation plant;
4. Neutralisation of the object in the plant.

All the phases of this process need to be organised and equipped to minimise the threat of incidental contamination of people and the environment. By definition, the CWAs involved are designed to kill irrespective of the cost to humanity and the environment. This threat is still real, in particular when large-scale operations are considered. Before any organisation can start the neutralisation of sea-dumped CWs and CWAs, it must prepare all feasible safety measures for every phase of the process. Particular difficulties with the neutralisation of gas munitions dumped at sea are the consequence of the fact that some tasks must be executed in spite of the instability of the operational conditions. This is an obvious situation when working at sea, where the weather can change dramatically within a single hour.

The investigation phase is the least threatening phase of the process of the neutralisation of the CWs. Except for cases where dumping sites were not properly marked on maps, the dumping sites can be detected and well documented by various available means. Remote sensing is mostly utilised during this phase, with TV cameras, photo cameras, sonars, magnetic and electromagnetic sensors used for this purpose. Chemical sensors and sample analyses of water sediments and living creatures are also utilised. Investigation is performed using remotely operated and autonomous vehicles, but commercial divers can be involved if required. Direct contact of equipment and people with CWAs can usually be avoided. From the safety point of view, it is important

that particular missions in this phase can be terminated at any time, without significant consequences. This may be necessitated by unfavourable weather conditions or any other unexpected circumstances. Investigation efforts are continuously performed by many institutions, while, from time to time, investigation “campaigns” are organised by local authorities and international consortia. In general, the practical results of such investigations and wider campaigns to date have been decisions “not to disturb deposits” and to allow the threat to slowly deteriorate (meaning to corrode, hydrolyse and dissolve) [7].

In the majority of cases, this is probably the most efficient approach as no technology has been developed and tested that allows the safe neutralisation of the indicated masses of CWs. However, this well-established approach is less feasible if the containers are deteriorating too fast or the dumping sites are located in environmentally or economically valuable areas. From the point of view of local citizens and enterprises, the areas with dumped CWs are always valuable, and the potential threat caused by their presence is always direct.

The technologies for the destruction of CW during the last phase of neutralisation processes are also comparatively well developed. This is particularly true in the case of gas-filled artillery shells. This is due to the well-known structure of the particular designs and the intrinsic robustness of the artillery shells. As seen in Fig. 4, their structures are well defined by procurement processes. If the shells are intact and have no detonators, they pose no serious safety problems. To allow the neutralisation of Cold War stockpiles of gas-filled projectiles, efficient industrial processing lines were developed [8][9]. Neutralisation plants are active in many countries but their capacity is very limited. Usually, they are based on heat processes (incineration and controlled detonation) that are quite well developed. Such permanent, land-based facilities require the munitions to be transported from their storage sites. Portable neutralisation facilities are also available, but devoted to single pieces of munition.

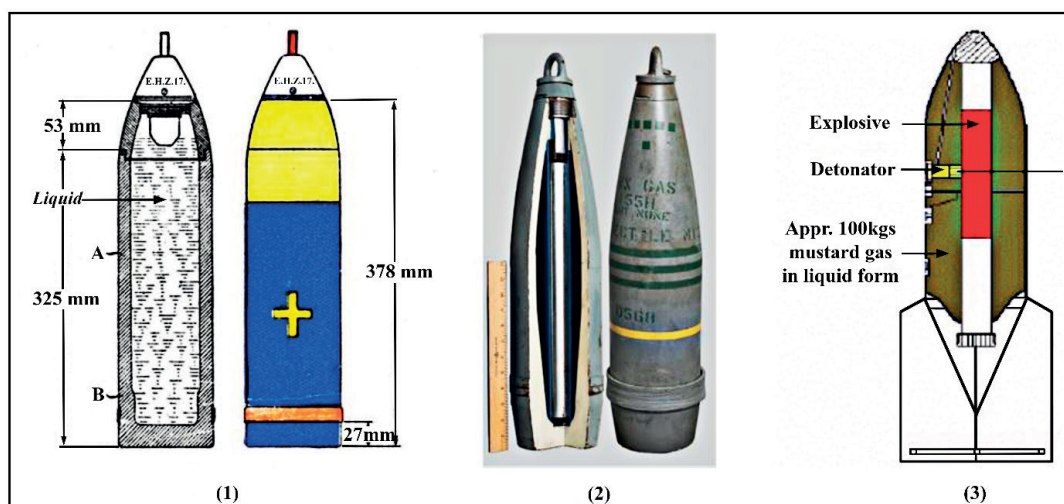

Fig. 4. Typical arrangement of gas-filled artillery shell: 1. German WWI mustard gas shells [10]; 2. US 155 mm chemical, M121A1 shell, chemical warfare agents (CWA) [11]; 3. German WWII mustard gas bomb KC 250 [5]

Similarly, in many cases, CWs in the form of artillery projectiles dumped at sea can be safely recovered and transported to incineration facilities. The difference, in comparison with new shells, is the questionable possibility of recovering the bursting explosive from aged devices before the chemical fill can be incinerated. In the case of gas containers and aerial bombs, the situation is much more complicated as these devices were less robust and are more susceptible to mechanical damage and corrosion. Such devices with chemicals exposed (Fig. 1) may not be simple to handle, recover and transport to the neutralisation facility. As mentioned above, the best solution in such cases is a decision “not to disturb”. Such deposits need to wait until procedures and technical means that ensure the safe recovery and transportation of large numbers of damaged containers and solidified chemical lumps are developed.

RECOVERY PHASE

Following the above statement, it is apparent that technical means that are able to ensure the safe recovery and transportation of dangerous objects need to be developed. This concerns the filled shells, leaking containers and even exposed chemicals. This is the pre-condition for safe, large-scale clearance of the sea bottom. The first step in the development process of a CW recovery system is the definition of requirements ensuring the fulfilment of operational and safety needs. The proposed requirements are listed below. While a CW recovery system must be well integrated, it is divided into two components: recovery equipment and a surface platform system, the latter being a platform from which the recovery equipment is launched and operated. The reason for the separate definition of requirements is the possibility of better identification of the required features and capabilities of each part of the system.

REQUIREMENTS REGARDING EQUIPMENT FOR CW RECOVERY PHASE

The recovery equipment is the least defined component in the whole process of CW neutralisation. This is why it needs to be defined to meet the requirements of the specific application. Of course, if a remotely operated underwater vehicle is considered, it must be built as a reliable work system that is able to operate at the required depth and sea current. According to the author’s analyses, the equipment (underwater vehicle) employed for the detailed investigation and recovery of dumped munitions and CWs in particular would also possess the following abilities:

1. Assess the chemical composition of the local environment, with constant monitoring of contamination levels from the CW during the recovery operation;
2. Firmly stabilise the equipment (work vehicle) on the bottom to allow detailed investigation of objects deposited on the bottom and buried in sediments without agitating these sediments;

3. Firmly stabilise the equipment (work vehicle) on the bottom to allow all kinds of manipulation tasks without agitating these sediments;
4. Move horizontally while in contact with the bottom with minimum agitation of bottom sediments;
5. Remove amounts of sediments to expose objects of interest without spreading the CW in the environment;
6. Accomplish the manipulation tasks required for assessment of the condition of an investigated object;
7. Remove semi-solid CWA from a site, without spreading the CWA in the environment;
8. Collect objects with mass of up to 250 kg (1000 kg if aerial bombs are included);
9. Isolate CWs and other objects containing CWA in dedicated containers;
10. Ascend with collected object without agitation of sediments by the operating thrusters.

REQUIREMENTS REGARDING SURFACE PLATFORM AND ITS OUTFIT

The requirements regarding the platform from which the recovery equipment is launched and operated are easier to define than those of the recovery equipment itself. Its minimum size is defined by the operating conditions and physical properties (size and weight) of the recovery equipment and its assumed functionality. As a minimum, it can be assumed that the functionality is limited to storage and transport of the recovered CW to a neutralisation facility. The remaining features and abilities ensure safety during normal operation and in emergencies.

Such a surface system (surface platform) used for the recovery of dumped munitions, and CWs in particular, would possess the following abilities:

1. Provide safe operation conditions for recovery equipment in the expected location (sea worthiness);
2. Provide protection for people (crew) against accidental contamination by the recovered CW;
3. Self-decontamination of the ship deck and deck equipment;
4. Decontamination of people (crew);
5. Decontamination of divers and diving equipment;
6. Decontamination of recovery equipment;
7. Storage of contaminated fluids;
8. Storage of recovered objects;
9. Storage of insulating containers with recovered objects;
10. Remotely controlled operation of the surface platform in the case of emergency contamination.

The requirements regarding the features listed above are considered to be the minimum for safe recovery and storage of recovered CWs. The neutralisation phase that needs to follow can be accomplished locally, or the recovered objects may need to be transported to an external neutralisation plant. The solution adopted would depend on the scale of the operation. For a small-scale intervention (removal of some insulated pieces of CW), transport to a land-based facility may be feasible. In the case of large-scale “bottom cleaning”, the application of a neutralisation ship (barge) seems to be more efficient.

PROPOSED SOLUTIONS

The dumped CW can be recovered using the well-established technology of classical diving. The equipment (classical diving suits) used for diving protects the persons (divers) involved from contact with chemicals and can be easily decontaminated. The recovered items can be insulated from the environment using simple, sealed containers. However, manual work at significant depth must be limited to individual cases, as it requires hard physical work that is difficult to accomplish at substantial depths. At depths greater than 50 m (for example Bornholm Deep and Gdansk Deep), saturation diving will be essential. It will be difficult to exclude accidents also. Of course, mechanical equipment (excavators and lifting machines) can be developed to support divers, but in fact, such equipment can be operated remotely without involving divers.

CONCEPT OF AN INTEGRATED CW RECOVERY SYSTEM BASED ON REMOTELY OPERATED VEHICLE

Based on the requirements listed above, the concept of a complete CW recovery system was defined. The system according to this proposal is used to recover and store (destroy) dangerous objects. Recovery and storage (destruction) activities are carried out using a surface platform with dimensions adapted to the expected environmental conditions and the size and amount of the recovered objects. The surface platform needs to be equipped with all means necessary for

safe operation of a work size, remotely controlled underwater vehicle and accompanying devices. The equipment used to recover hazardous objects from the bottom has the form of a two-component underwater remotely operated vehicle. The total mass of the vehicle is estimated at between 3 and 5 tons, depending on the assumed size and mass of recovered objects. One part of the vehicle is a transport or propulsion module and the second part is a bottom module. All the bottom activity is performed by the bottom module, while the propulsion module transports equipment and recovered objects between the bottom and surface platform. This solution was selected to minimise the agitation of bottom sediments by the hovering submersible. This is an important feature according to the requirements listed above. The transport module is equipped with an observation unit, a navigation suite, a propulsion system and a very capable ballast system. The ballast system adjusts the buoyancy of the transport module in a range suitable for moving the bottom module in the water space and for lifting the expected objects from the bottom. For the majority of cases, the buoyancy changes would be in the range of 0 to 2.5 kN. If handling of aerial bombs or large barrels is considered, buoyancy changes in the range of 0 kN to 10 kN or an even wider range needs to be provided. The transporting module is designed with the minimal number of appendages as these would be difficult to decontaminate. An insulating container is attached to the bottom of the transport module and utilised for transportation of the most dangerous objects after they are lifted from the bottom. The concept of the insulating container is shown in Fig. 5.

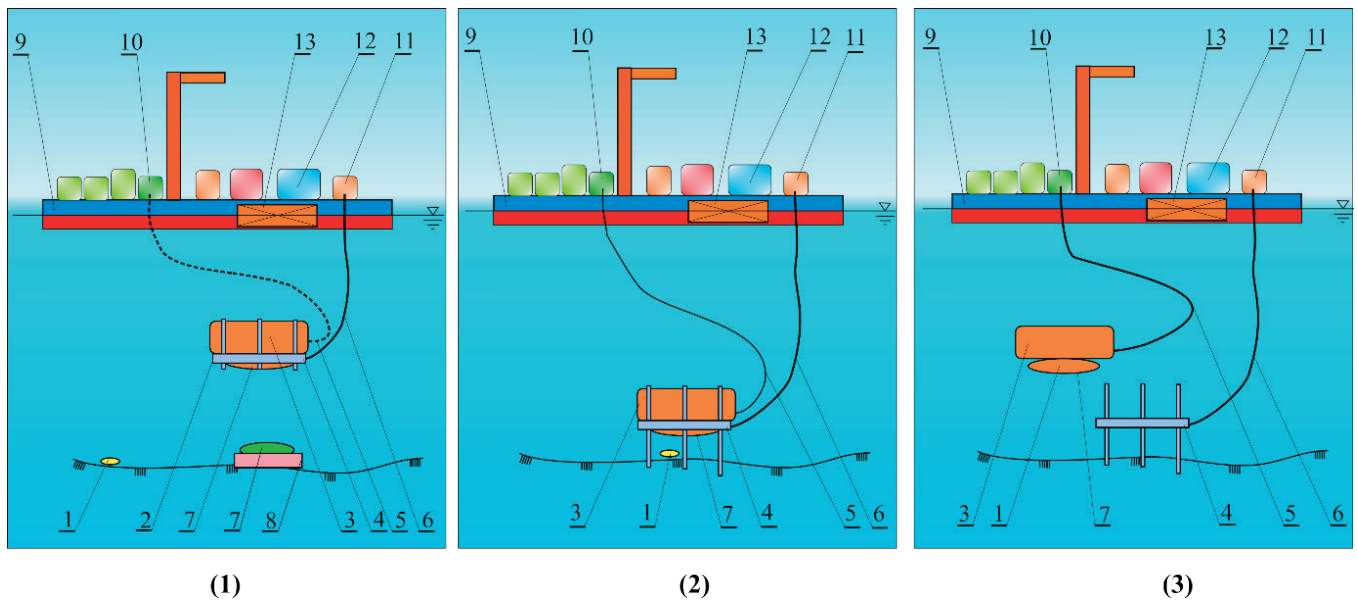

Fig. 4 General arrangement of the proposed gas munition recovery system: 1. The vehicle consisting of a drive module and a bottom module, swimming to a dangerous object; 2. The vehicle over an UXO with the legs extended and stabilised on the bottom; 3. The drive module with the container floats to the surface while the bottom module remains on the bottom near the next object to be lifted from the bottom, or waiting to be moved by the drive unit to a new job site. 1. UXO; 2. ROV; 3. Transporting module; 4. Bottom module; 5. Umbilical of transporting module; 6. Umbilical of bottom module; 7. Insulating container; 8. Temporary storage frame; 9. Surface platform; 10. Transporting module winch; 11. Bottom module winch; 12. Decontamination compartment; 13. Contaminated water tank [Author's drawing]



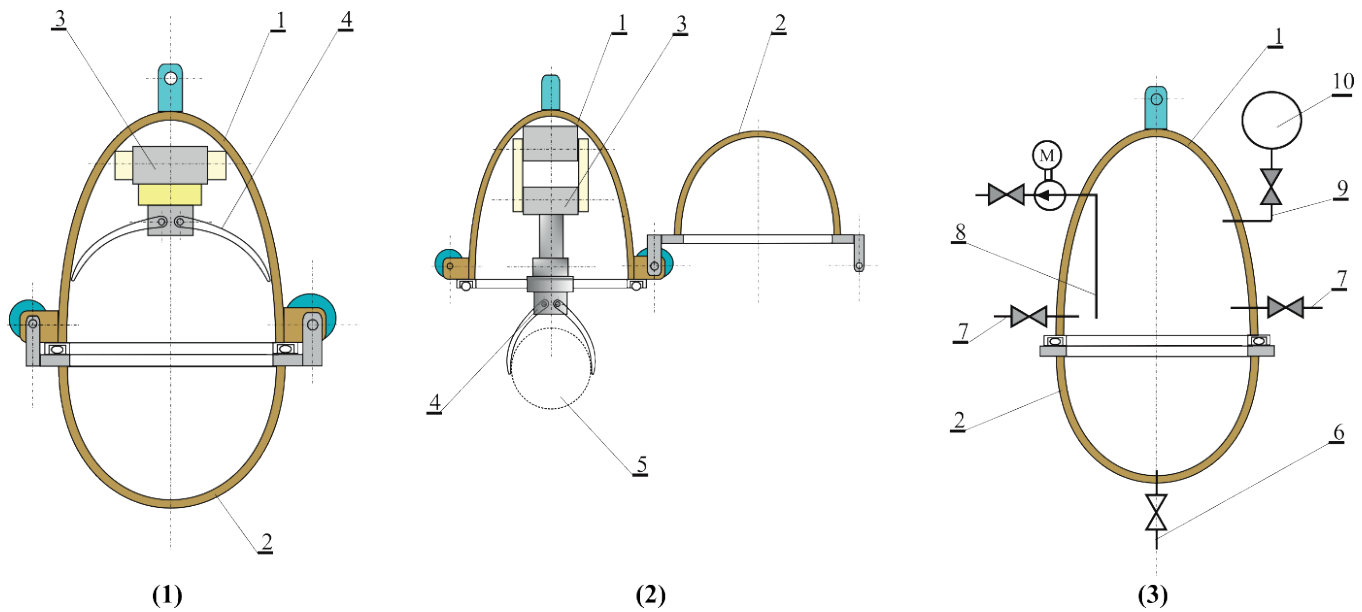

Fig. 5. Concept of an insulating container for recovered leaking CW and badly damaged containers with exposed CWA. 1. General arrangement of the insulating container with internally mounted manipulation and CW object handling; 2. The insulating container in open configuration and CW object in the manipulator; 3. Tubular outfit of the insulation container that allows for control of atmosphere inside the closed container. 1. Insulating container; 2. Container cover; 3. Manipulator arm; 4. Manipulator claws; 5. Recovered object; 6. Drain pipe; 7. Chemical treatment pipes; 8. Water removal pipe; 9. Gas purging pipe; 10. Gas canister
[Author's drawing]

The second part of the underwater vehicle is the bottom module. Initially, it is attached to the transport module in a detachable manner and transferred to the munition dump site. The bottom module is a working platform capable of walking on the bottom on six legs and stabilising the vehicle during handling (manipulation) activities. The spider-like configuration of the motion system, which allows for movement in any direction, was selected to meet the requirement regarding the minimum agitation of sediments during relocation of the bottom module. It also allows for significant movement in the horizontal plane without retracting the legs from the sediment, levelling of the platform and control of the distance between the chassis of the bottom module and the bottom itself. The majority of the manipulating devices applied in the recovery of CWs are fixed to the chassis of the bottom module, together with the illumination devices, cameras and sensors used to assess the contamination levels. This solution minimises the possibility of accidental surfacing of equipment contaminated with CWAs. An important feature is the capability of the design to allow precise cleaning of objects of interest using water jetting of sediments and the object surface to remove rust and other debris. At the same time, any developing slurry can be pumped out to some distance from the working vehicle or pumped to the surface for treatment or/and storage. This arrangement allows for the recovery of liquid and semi-solid CWAs without the need to recover lumps of chemicals that may be difficult to handle. Semi-solid CWAs can be cut to small pieces mechanically or using high-pressure water-jets and sucked off.

Both modules of the underwater vehicle are connected by means of two separate umbilicals to equipment mounted

on the surface platform. These umbilicals are connected to two dedicated winches mounted on the surface platform. The umbilical of the transporting module has a typical ROV positive buoyancy structure, containing power and communication components. The umbilical of the bottom module contains additional components in the form of an elastic pipe (hose). This is provided for pumping of the contaminated water and slurry generated during handling of leaking CWs and CWAs without containers. Therefore, the dedicated winch of the bottom module is designed to transfer contaminated fluids and suspended solids to storage tanks and treatment facilities.

The surface platform is basically designed to support the operation of the underwater part of the system. For this purpose, it is equipped with appropriate lifting devices and cranes, control rooms, and power supply devices (generators). For safety reasons, the surface platform is anchored at some distance from the work site. The distance needs to be sufficient to exclude damage due to any possible underwater explosion. To allow the handling of CWs and CWAs, dedicated containers (rooms) and tanks are provided. These are used for the deactivation and storage of hazardous objects, fluids and gases. It is recommended that a complete line for destroying UXO of all types and CWAs in containers at any technical condition will be assembled on the surface platform.

In order to extract a dangerous object from the bottom, the position of the surface platform is stabilised in the vicinity of the object or set of such objects (i.e. a dumping site). Then, the underwater vehicle composed of the two modules is launched from the deck of the surface vessel by means of a crane specific for the handling of ROVs. When the vehicle is submerged, the winches located on the platform unwind appropriate lengths

of both umbilicals. After reaching a dangerous object, the underwater vehicle stands on the bottom on extendable legs. The pressure the vehicle exerts on the bottom is regulated by means of ballast devices. Then, using the mobility properties of the legs, the vehicle moves towards the dangerous object so that it is under the body of the vehicle and within reach of the manipulating arms. By means of observation, aided by handling activities, including washing out and sucking out debris and corrosion products of the elements of the potentially dangerous object, it is identified and evaluated. It is envisaged that the water contaminated with chemicals is sent to the ship's neutralising equipment. After a thorough inventory of the object in terms of the type, degree of damage and level of danger, the object or its elements are lifted by the internal manipulator of the hermetic insulating container and closed inside it. After enclosing the dangerous object in the insulating container, the underwater vehicle separates into the bottom module and the transport module. The bottom module remains anchored on the bottom with its legs in the sediments. The transport module floats to the surface after balancing the weight of the object by means of the buoyancy control system. Then it is lifted by the ship's crane and placed in the insulating sluice of the decontamination system. In this sluice, the transport container is detached from the transport module. Another transport container is then attached to the transport module, which is lowered back into the water and down to the bottom module standing on the bottom.

After reconnecting the drive module and the bottom module, lifting of objects from the bottom continues. In the case of recovering multiple objects located in proximity, the vehicle combined with the transporting module approaches the next ones (objects) using leg movements. Of course, while dealing with safe objects (not damaged or leaking), the recovery operation can be simplified. In such a case, CWA-filled shells or containers can be loaded (several pieces) into unsealed recovery containers using manipulators and lifted to the surface platform.

If, when lifting a dangerous object into an insulating container, the surface of this container and the transport module is heavily contaminated (e.g. when lifting a lump of chemical agent from a corroded container), the vehicle puts the container with the dangerous object on the storage frame located at the bottom and picks up another container from this frame. The storage frame with insulating containers containing dangerous objects is lifted to the surface after the contamination drops to a level considered safe. According to available data, such "natural" decontamination of thin layers of chemicals usually requires less than 24 h exposure to sea water [4]. After removing all the hazardous objects from the bottom, the legs of the vehicle are released from the bottom sediments and the underwater vehicle is moved to another location to perform further tasks. If work is finished at one spot, the vehicle swims to the surface and is lifted on board the surface platform, cleaned and prepared for the next operation.

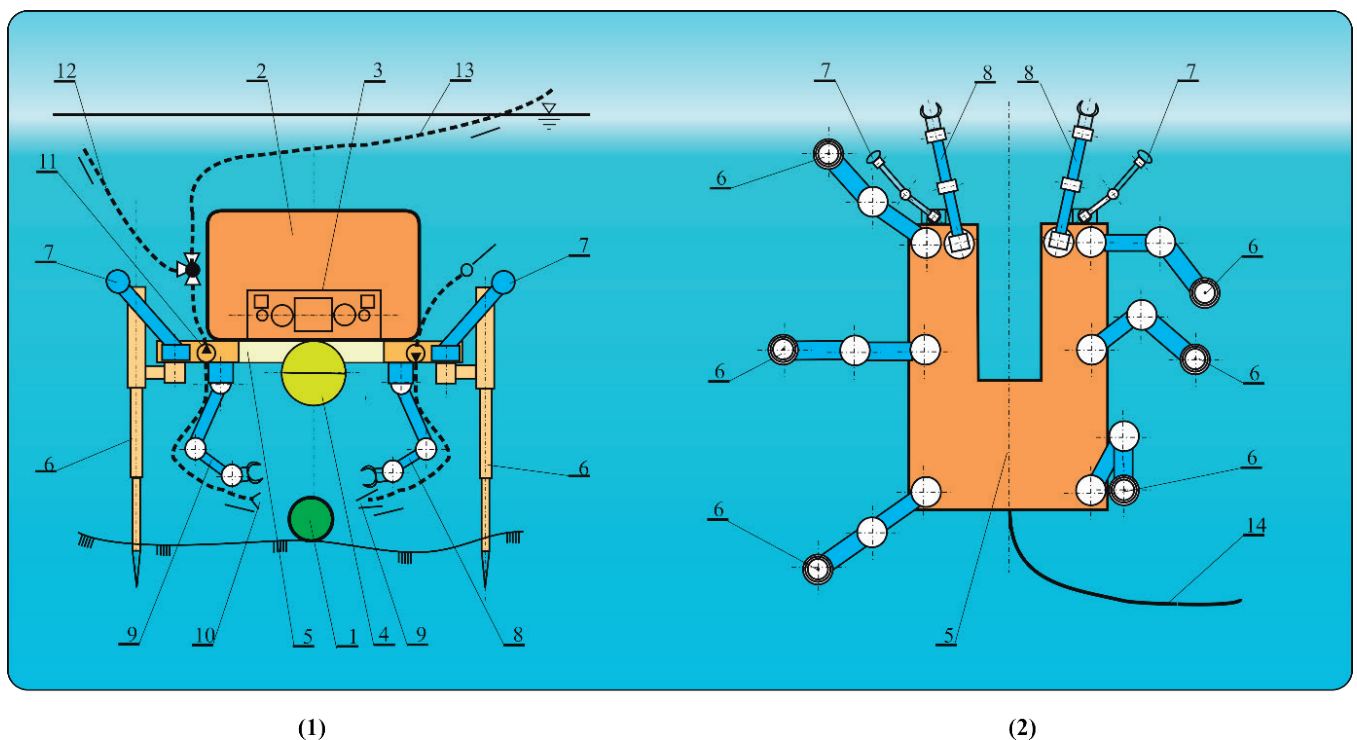

Fig. 6. Basic features of gas munition recovery vehicle composed of legged bottom module and transportation module equipped with insulating container.
 1. UXO; 2. Transporting module; 3. Observation equipment; 4. Insulating container; 5. Bottom module; 6. Leg; 7. Lamp; 8. Manipulator; 9. Water jetting nozzle;
 10. Sediment/CWA slurry suction cup; 11. Slurry transfer pump; 12. Sediment slurry discharge hose; 13. Sediment/CWA slurry hose for surface treatment;
 14. Umbilical of the bottom module
 [Author's drawing]



SUMMARY

It is apparent that the large-scale neutralisation of sea-dumped warfare materials is a really great challenge to the nations, governments and international organisations involved. One can assume that the recovery of some 100,000 items from the most threatening European deposits will realistically take 10 years. An operation on this scale would require the procurement of some 50 active and efficient recovery and neutralisation systems manned with 5000 personnel. As seen from a brief investigation of the current solutions, the availability of adequate “industrial” technologies is very problematic. Safe neutralisation of unexploded ordnance, chemical weapons and warfare chemical agents, in particular those dumped at sea, requires the development of suitable technologies, equipment and procedures. Due to under-development of the recovery phase of the neutralisation process, strong (inter-governmental) support for research and development in dedicated equipment is required. It is apparent that for the scale of the task of “cleaning” the bottom, really substantial development effort is required. Based on the discussed requirements, other new proposals need to be created, developed and tested in practice. Testing in practice means testing on real dumping sites. This needs to be done before the selected method and equipment are approved as safe for people and the environment. Otherwise, the only practical solution will remain “not to disturb” and to allow the dumped materials to slowly deteriorate with time.

REFERENCES

1. J. Beldowski *et al.*, “Chemical munitions search & assessment - An evaluation of the dumped munitions problem in the Baltic Sea,” *Deep. Res. Part II Top. Stud. Oceanogr.*, vol. 128, 2016, doi: 10.1016/j.dsr2.2015.01.017.
2. I. Wilkinson, (Middlebury Institute of International Studies in Monterey), “Chemical weapon munitions dumped at sea: An interactive map,” 2017. <https://nonproliferation.org/chemical-weapon-munitions-dumped-at-sea/>
3. Anonymous, “Chemical weapons material dumped at sea; Interactive map,” 2017. https://www.google.com/maps/d/viewer?ll=5.368292378570265%2C0&z=2&mid=1ALnyOrN5JQ8H50znwJqI_Sj8IwE
4. J. Beldowski, “Chemical munitions dumped in the Baltic Sea. Report of the ad hoc expert group to update and review the existing information on dumped chemical munitions in the Baltic Sea (HELCOM MUNI),” in *Baltic Sea Environment Proceedings (BSEP)*, No. 142, p. 128, 2013. [Online]. Available: <https://helcom.fi/wp-content/uploads/2019/08/Dumped-chemical-munitions-in-the-Baltic-Sea.pdf>
5. Anonymous, “A framework for developing national guidelines for fishermen on how to deal with encounters conventional and chemical munitions,” 2004. [Online]. Available: <http://www.environet.eu/pub/pubwis/rura/20070113123123.pdf>
6. Anonymous, “Overview of past dumping at sea of chemical weapons and munitions in the OSPAR Maritime Area 2010 update,” 2010. [Online]. Available: https://www.ospar.org/ospar-data/p00519_2010_revised_dumping_at_sea_of_munitions_and_weapons.pdf
7. Anonymous, “Government won’t remove thousands of tons of potentially toxic chemical weapons dumped off US coasts,” 2017. <https://underwatermunitions.org/2017/10/17/government-wont-remove-thousands-of-tons-of-potentially-toxic-chemical-weapons-dumped-off-us-coasts/>
8. M. Geuss, “In southeastern Colorado, robots carefully disarm WWII-era chemical weapons,” 2017. <https://arstechnica.com/science/2017/02/in-southwestern-colorado-robots-carefully-disarm-wwii-era-chemical-weapons/>
9. M. de Yoanna, “In Pueblo, America’s chemical weapons era nears an end,” 2019. <https://www.kunc.org/news/2019-08-08/in-pueblo-americas-chemical-weapons-era-nears-an-end>
10. S. Jones, “Yellow Cross: the advent of mustard gas in 1917,” 2007. <https://simonjoneshistorian.com/2014/02/04/yellow-cross-the-advent-of-mustard-gas-in-1917/>
11. Anonymous, “US Projectile, 155mm Chemical, M121A1.” https://www.bulletpicker.com/projectile_-155mm-chemical_-m4.html
12. R. Miętkiewicz, “Do WWII weapons dumped in the Baltic Sea pose a threat to wind energy?,” 2022. <https://balticwind.eu/do-wwii-weapons-sunk-in-the-baltic-sea-pose-a-threat-to-wind-energy/>
13. Anonymous, “Removal of hazardous substances from the bottom of the Baltic Sea – solution of Remontowa Holding,” 2021. <https://www.polandatsea.com/removal-of-hazardous-substances-from-the-bottom-of-the-baltic-sea-solution-of-remontowa-holding/>
14. J. Donovan, “Method and apparatus for the destruction of suspected terrorist weapons by detonation in a contained environment,” WO2001048437A1, 1999 [Online]. Available: <https://patents.google.com/patent/WO2001048437A1/en>
15. M. J. R. Carr, C. Sennett, and B. Wilkinson, “Remote control robot vehicle,” US Patent 4621562, 1986. [Online]. Available: <http://www.google.com/patents?hl=en&lr=&vid=USPAT4621562&id=fqQzAAAAEBAJ&a>

mp;oi=fnd&dq=Remote+control+robot+vehicle&am
p;printsec=abstract. [Accessed: Feb. 11, 2012].

16. J. Barton, "Remotely operated, underwater non-destructive ordnance recovery system and method," US 7363844 B2, 2006 [Online]. Available: <https://patents.google.com/patent/US7363844B2/en?q=US+7%2C363%2C844+B2+>
17. J. Koebel, "Method and device for disposing of a piece of unexploded ordnance lying under water," EP3479052B1, 2017 [Online]. Available: <https://patents.google.com/patent/EP3479052B1/en?q=EP3479052B1>
18. N. Scheffer and M. Freudenthal, "Method and apparatus for deactivating unexploded ordnance located under water," WO2020030558A1, 2018 [Online]. Available: <https://patents.google.com/patent/WO2020030558A1/de?q=WO2020030558A1>

