

PASSIVE SAMPLING

Tadeusz Górecki, Jacek Namieśnik*

Department of Chemistry, University of Waterloo, Ontario, Canada

**Chemical Faculty, Technical University of Gdańsk, Poland*

Abstract

Passive sampling is based on free flow of analyte molecules from the examined medium to a collecting medium caused by a difference in chemical potentials. It can be used for the determination of both inorganic and organic compounds in a variety of matrices, including air, water and soil. The devices used for passive sampling are usually based on diffusion through a well-defined diffusion barrier or permeation through a membrane. Living organisms can also be used as passive samplers. In most cases, passive sampling vastly simplifies sampling and sample preparation, eliminates power requirements, and significantly reduces the costs of the analysis. The technique is particularly suited for the determination of time-weighted average concentrations.

Keywords: Sampling, sample preparation, passive techniques, air and water analysis, biomonitoring.

Introduction

Sampling is arguably the most important step of any analytical procedure. Errors committed at this stage cannot be corrected later during the analysis. A plethora of sampling methods exist, depending on the nature of the analyte(s) and their concentration levels. In the simplest scenario, a subsample of the material of interest (e.g. water, air) is analyzed directly, either on site, or in the

laboratory following collection into a suitable container. However, with few exceptions, this approach is limited to the determination of major components in relatively simple matrices. In most other cases, it is necessary to perform additional operations on the sample prior to the final determination. These operations typically involve isolation of the analyte(s) from the matrix (to reduce or eliminate possible interferences) and its preconcentration (to improve the sensitivity of the method). It may also be necessary to change the matrix or the form in which the analyte is present into one that is compatible with the instrument used for the final determination. Consequently, many sample preparation procedures, especially in the analysis of trace components in complex matrices (e.g. environmental or biological) involve numerous steps, each of which may require hours to complete.

According to various estimates, sampling and sample preparation typically account for 70 to 90% of the analysis time. It is quite obvious therefore that very often the biggest gains in the overall response time of the analytical system can be realized by reducing the time necessary to process the samples. Thus, a great effort is going into the development of reliable sampling/sample preparation procedures characterized by the simplicity of both the operations and the devices involved in the process. One of the prevailing trends is combination of several steps into one, e.g. sampling and sample preparation. Elimination or significant reduction of the amount of solvents used during sample preparation is also a priority, as it might reduce the costs of the analysis, as well as the amount of time and labour required to process a sample. In addition, solventless methods are often more sensitive than their “classical” counterparts. It is also worth mentioning that solventless techniques are one of the cornerstones of so-called “green analytical chemistry”, a concept which is gaining importance very rapidly.

Passive sampling techniques fulfil many of the requirements listed above. They usually combine sampling, analyte isolation and preconcentration into a single step. Barring some exceptions described later, most passive sampling techniques require little or no solvent. In the context of this issue it should be pointed out that passive methods usually simplify sample pretreatment and are very easy to implement. However, as passive sampling is usually carried out to determine time-weighted average (TWA) concentrations, its “response speed” is normally determined by the duration of the period for which TWA is being determined. This paper presents a review of passive sampling techniques, including the principles of passive sampling and selected applications. The following two sections are based in large part on review papers summarizing the basic knowledge on passive sampling [1,2,3,4,5,6,7] with the balance being mostly our own findings and ideas, therefore references to individual original papers will be given only when necessary.

Principles of Passive Sampling

Passive sampling will be defined in this paper as any sampling technique based on free flow of analyte molecules from the examined medium to a collecting medium, caused by a difference in chemical potentials of the analyte between the two phases. Net flow of analyte molecules from one medium to the other continues until equilibrium is established in the system, or until the sampling session is terminated by the user. In the former case, the amount of analyte collected by the sampler once equilibrium has been reached does not change with time provided that the analyte concentration in the medium examined does not fluctuate. This concentration can then be determined based on analyte distribution ratio between the two phases involved or experimental calibration of the device.



When sampling continues until the sampling session is terminated by the user, the amount of analyte collected by the sampler depends both on its concentration in the medium examined, and on the exposure time. If the relationship between the sampling rate and analyte concentration is known, time-weighted average (TWA) analyte concentration can be easily determined, which is very advantageous. However, several conditions must be met for this approach to work. First, the receiving medium must act as a so-called “zero sink”, i.e. it should not let the trapped molecules be released even if the concentration of the analyte around the sampler decreases to zero. The second condition is that the sampling rate (the amount of analyte collected by the sampler per unit time at constant concentration in the surrounding medium) must remain constant throughout the sampling session. This can be easily accomplished when the analyte is absorbed (e.g. into a liquid receiving phase) or chemisorbed, but can be problematic when physical adsorption is responsible for analyte collection. Only the linear portion of the adsorption isotherm should be utilized in this case throughout the entire sampling process. Typically, this is accomplished by using high-capacity sorbents at low mass loadings (i.e. far from thermodynamic equilibrium). However, since adsorption is a competitive process, the linear range of the adsorption isotherm can be easily exceeded whenever other molecules are trapped in large amounts alongside the analyte molecules. A typical example is sorption of water by hydrophilic adsorbents. Accurate conversion of the amount of analyte trapped into its TWA concentration becomes essentially impossible in such cases.

An interesting consequence of adopting the definition of passive sampling given at the beginning of this chapter is that it encompasses more than conventional passive sampling techniques. In fact, we also have to include under this definition many techniques used in biomonitoring. For example, the partitioning of persistent organic pollutant molecules between water and fish



adipose tissue is driven by the difference in chemical potentials of these molecules between the two phases, therefore it fulfils the criteria of passive sampling. Table 1 presents a classification of passive sampling techniques. Following is a description of the principles of “classical” passive sampling. Biomonitoring techniques are shortly dealt with at the end of this paper.

Passive sampling was used for the first time for semi-quantitative determination of CO in 1927 [8]. Truly quantitative passive sampling was introduced in 1973 (determination of NO₂ [9] and SO₂ [10] in air). Hundreds of papers devoted to the development of new types and applications of passive samplers have been published since then. Even though implementation details between different types of passive samplers vary widely, nearly all passive samplers share certain common characteristics, the most important of which is the presence of a barrier between the sampled medium and the collecting medium. The barrier should define the rate at which analyte molecules are collected at a given concentration, which is crucial for quantitative analysis. It should also eliminate or minimize the effects of external factors (e.g. velocity of the sampled medium at the face of the sampler, humidity, temperature, etc.) on the sampling rate. In practice, the barrier usually falls into one of two categories: a diffusion barrier or a permeation barrier. These categories form the basis for the most general classification of passive samplers into diffusion and permeation ones. Schematic diagrams of the two types of samplers are presented in Figure 1.

The sampling process is similar for both types of samplers. Once they are exposed to the medium examined, they collect analyte molecules reaching the collecting medium by diffusion through a static layer of the examined medium contained in well-defined opening(s) in the sampler, or via permeation through a non-porous membrane. In both cases, the driving force for the transport is the difference in chemical potential of the analyte on both sides of the barrier. This difference

arises when analyte molecules are trapped by the collecting medium, which results in concentration or vapour pressure gradient across the barrier. An ideal collecting medium has 100% collection efficiency, i.e. analyte concentration near the surface of the medium is zero. In practice, the collection efficiency rarely approaches the ideal limit, and consequently the concentration gradient is usually smaller.

Once the sampling session is completed, the amount of the analyte collected must be determined. This is done using various procedures, the details of which differ depending on the sampler type, medium examined, etc. Interested readers can consult some of the numerous review papers published on this topic (e.g. [1,2,3,4,5,6,7,11,12]) and the references cited therein. The last step in any procedure is the conversion of the amount of analyte found in the sampler after the measuring session into its concentration (usually TWA) in the medium examined.

Theory of Passive Sampling

Comprehensive theory of passive sampling has been presented in a number of publications (e.g. [3,6,13] and references cited therein), therefore only a brief outline will be presented.

Diffusional mass transfer, both through a static layer of the medium examined and across a membrane, can be described by Fick's first law of diffusion. The amount M of the analyte transported by diffusion in time t (s) when the concentration gradient is linear and the collection efficiency is 100% can be described by the following relationship:

$$M = U \times t = \frac{DA}{L} c_0 t \quad (1)$$



where U is the diffusive transport rate (mol/s), D is the molecular diffusion coefficient of the analyte (cm²/s), A is the cross section of the diffusion path (cm²), L is the total length of the diffusion path (cm) and c_0 is analyte concentration in the medium examined (mol/cm³). The term DA/L is expressed in cm³/min, same as sample flow rate in dynamic devices. Consequently, it is often considered to be the sampling rate (SR). For a device with a defined geometry and at constant temperature, $SR = DA/L$ should be constant for a given analyte. Thus, as long as exact geometry of the sampler (A and L) is known, it should be possible to calculate c_0 based on the literature value of D . However, several factors make this approach impractical. The values of the molecular diffusion coefficient for a given compound often differ between literature sources, and the data on the temperature dependence of D are often incomplete. Other factors include analyte losses through sorption to various parts of the sampler, as well as collection efficiency lower than 100%. Thus, in practice, it is most often necessary to calibrate each sampler.

Fick's first law of diffusion is also applicable when the rate of analyte mass transfer is controlled by permeation through a membrane. For gas sampling, the amount of analyte M collected after time t by such a sampler equipped with an ideal collecting medium can be described by:

$$M = \frac{SA}{L_M} p_1 t \quad (2)$$

where M and A have the same meaning as in equation (2), S is the permeability coefficient of a given analyte (cm²/min), L_M is membrane thickness (cm), and p_1 is partial pressure of the analyte near the external membrane surface.

Partial pressure of the analyte can be easily converted to its concentration in air using ideal gas law. Taking into account that unit conversion is often required, one can simply write that:

$$p_1 = aC_0 \quad (3)$$



where a is a constant. At constant temperature, S , A , a and L_M are constant, and can be replaced by:

$$\frac{1}{k} = \frac{SAa}{L_M} \quad (4)$$

where k is so-called calibration constant. Thus, concentration of the analyte can be determined once M and t are known using the relationship:

$$C_0 = \frac{Mk}{t} \quad (5)$$

The response time of passive samplers is determined by the rate of analyte transport through the diffusion or permeation barrier, which, in turn, depends on the magnitude of the diffusion coefficient of the analyte in the material of the barrier (sampled medium in the former and semi-permeable membrane in the latter case) [6]. For diffusive passive samplers the response time is defined as:

$$t_R = \frac{L^2}{2D} \quad (6)$$

where t_R is the residence time of a compound in the diffusion zone. For gas sampling, the response time is typically on the order of seconds. Thus, it is negligibly small compared to overall sampling time. A similar relationship describes the response time of permeation passive samplers:

$$t_R = \frac{L_M^2}{6S} \quad (7)$$

Even though the permeability constant of a compound is typically several orders of magnitude lower than the diffusion coefficient of the same compound in the medium examined (especially

air), the response time of a permeation passive sampler can still be very short if the membrane is thin enough. For membranes thinner than 100 μm , the response time is on the order of seconds.

Temperature is also an important parameter in passive sampling. Molecular diffusion coefficients increase with temperature, therefore increased sampling rates can be expected for diffusion samplers as temperature increases. For gases, the kinetic theory predicts that diffusion coefficients are proportional to $T^{3/2}$ (where T is absolute temperature). Thus, within the temperature range of 5 to 35°C, the diffusion coefficient (and consequently the sampling rate) should theoretically change by 16%. In practice, a weaker temperature dependence of 0.2%/1°C was observed [13].

Temperature effect on the sampling rate is usually much smaller for permeation-based passive samplers. The temperature dependence of the permeability coefficient S can be described by the relationships:

$$S = S^0 \exp(-E_p / RT) \quad (8)$$

$$E_p = \Delta H + E_D \quad (9)$$

where S^0 is the standard permeability coefficient and E_p is the activation energy for permeation, which is the sum of the heat of solution of the analyte in the membrane material (ΔH) and the activation energy for diffusion (E_D). Since E_p is typically small (≤ 10 kcal/mol), either a very weak or virtually no temperature dependence of the sampling rate is usually observed in the ambient temperature range.

Practical Implementation of Passive Sampling

Passive samplers can have many different forms, depending on the sampling principle and the medium examined. Since gas sampling by passive devices is the most widespread, it will be discussed first.

Gas sampling

Passive air samplers are manufactured by numerous suppliers of analytical equipment (e.g. Perkin-Elmer, Draeger, 3 M, SKC Inc., Du Pont). They can be most generally classified into two types: tube and badge. Diffusive samplers are most often tube-type devices (see Figure 1). The tubular part of the sampler defines the diffusion barrier, with the cross section of the tube determining the A term, and the length determining the L term in Equation (2). The geometry of tube-type diffusion samplers is very important. If the diffusion barrier defined by the sampler is not efficient enough, the sampling rate of the sampler can be so high that it leads to depletion of the analyte in the air around the tube inlet, especially when the air around the inlet is stagnant or moves very slowly. Consequently, the sampling rate of the sampler decreases, and the accuracy of the measurement suffers. This effect can be eliminated either by making sure that air velocity around the sampler is high enough (e.g. in personal monitoring), or by properly selecting the geometry of the sampler. Overall, the effect of ambient air velocity decreases when the diameter of the sampler decreases, and practically disappears when then length/diameter ratio (L/A) reaches 7:1 [14].

Badge-type diffusion samplers are also used. A layer of microporous material separating the collecting medium from the outside air usually defines the diffusion barrier in such devices. The



length of the diffusion barrier L can be approximated by the thickness of the porous layer, and the total area of the pore openings determines the cross-section area of the diffusion path A .

Recently, solid-phase microextraction [15] (SPME) has been proposed as an interesting alternative to conventional diffusive passive samplers [16,17]. SPME is a sampling technique based on equilibration of the analytes between the matrix and a stationary phases coated on a fused silica fibre housed inside a 26-gauge needle. Time-weighted average sampling by SPME can be accomplished by leaving the fibre inside the needle during the sampling session, so that a “micro” tube-type diffusion sampler is created. In this configuration, illustrated in Figure 2, analytes diffuse along a well-defined diffusion barrier between the needle opening (cross-section area A) and the front face of the fibre. The length of the diffusion path L , and consequently the sampling rate, can be adjusted by retracting the fibre more or less into the needle. The very small area of the needle opening virtually eliminates the effect of ambient air velocity on the sampling rate.

One limitation in the use of SPME for passive sampling is the availability of coatings that can act as “zero sinks”. The most popular poly(dimethylsiloxane) (PDMS) coating can be used for this purpose only for analytes whose coating/air partition coefficients are greater than ~ 1000 [16]. On the other hand, analyte sorption onto the metal needle itself may affect the measurement accuracy for semi-volatile analytes [17]. The first problem can be overcome by using coatings with higher affinities to the analytes of interest (e.g. porous polymer coatings), or by derivatizing the analyte(s) on the coating to stable products with high affinities. The latter approach was demonstrated for the analysis of formaldehyde in air [18,19]. The use of deactivated steel needles was suggested to overcome the second problem [17]. In the context of this issue it is interesting to note that grab sampling of formaldehyde by SPME combined with on-fibre derivatization and



field GC analysis fulfils the requirements of a fast response analytical system. Formaldehyde concentrations in air in the low ppbv range were determined using this combination in a matter of minutes [20].

Permeation passive samplers are most often badge-type, although tube-type designs are also known. The badge design is dictated by the need to have a large surface area of the membrane, in order to achieve useful sampling rates. Air velocity has virtually no effect on the sampling rate of permeation samplers because the permeability constants of the analytes are several orders of magnitude lower than their diffusion coefficients in air. Consequently, analyte depletion in the vicinity of the sampler does not occur even in stagnant air. Figure 3 presents an example of a badge-type permeation passive sampler using a bed of granulated sorbent as the collecting medium. A more detailed description of a number of different passive sampler designs, both commercial and custom-made, can be found for example in [6]. Figure 4 presents examples of the design of two commercially available passive samplers.

Determination of the amount of analyte collected by the sampler is the last experimental step in the process. In some designs, the amount of the analyte can be determined directly, e.g. from the length of a colour stain (as in indicator tubes). In vast majority of cases, however, the analyte (or its conversion product) must be isolated from the collecting medium prior to its final determination. Some samplers are designed in such a way that the isolation process can be carried out inside the sampler itself (e.g. the sampler is flushed with a solvent or subjected to thermal desorption - see Figure 4). In other designs, the collecting medium must be first transferred to a suitable device or vessel. The manner in which final determination is carried out depends on the analyte and the sampler type.



It should also be pointed out that in many cases the sampling process must be preceded by calibration of the sampler. This is usually done by exposing the sampler to a known concentration of the analyte(s) for a defined period of time, followed by the determination of the amount of the analyte collected and calculation of the sampling rate.

Liquid sampling

Passive sampling of liquid samples has a much shorter history than passive sampling of gaseous samples. Södergren was the first to use a hydrophilic dialysis bag filled with hexane to passively sample non-polar aqueous pollutants [21]. Passive devices for water sampling used today generally fall into the same two categories as passive samplers for gases, i.e. membrane- and diffusion-based devices, with the former being more widespread. An in-depth discussion of passive sampling in water can be found in reference [11].

Membrane-based passive samplers fall into two main categories: semi-permeable membrane samplers (SPM) including semi-permeable membrane devices (SPMD) and supported liquid membrane devices (SLM). In the simplest implementation, an SPM is a bag or a tube (often lay-flat) made of a suitable material and filled with a liquid collecting medium. Although dialysis membranes were mostly used in early studies, they suffer from several drawbacks, including relatively low chemical stability and susceptibility to microbial degradation. Non-porous films made of hydrophobic synthetic polymers (e.g. polyethylene or polypropylene) are more resistant to solvents and biodegradation, therefore they are generally more advantageous for SPM applications. Typical concentration factors reported for SPM samplers of this kind are of the order of several hundred.



SPM samplers of more complex designs are also used. Kot and Wasik [22] introduced a sampler of a design similar to the one presented in Figure 3, the main difference being that for water sampling the device is solvent- rather than sorbent-filled. Litten et al. [23] introduced a device called PISCES (passive in situ concentration/extraction sampler), which is a solvent-filled passive sampler equipped with two polyethylene membranes to maximize the sampling rate.

The use of solvents as collecting media has both its advantages and disadvantages. Solvents collect analytes from water through partitioning, driven by the difference in chemical potentials of the analyte in water and in the solvent. The process is non-competitive, therefore matrix effects should be minimized, and the sampling rate should remain constant as long as the driving force (i.e. the difference in chemical potentials) remains constant. However, if the solvent is allowed to reach equilibrium with the analyte dissolved in water, no more net flow of the analyte occurs between the two phases. In this scenario, the amount of analyte collected in the solvent may not reflect the true TWA concentration of the analyte in water. In fact, a decrease in the sampling rate was observed for the PISCES device when solvent-water partitioning approached equilibrium. It is important therefore not to allow the partitioning process to reach equilibrium if TWA concentration is the target information. In addition, it should be remembered that partitioning is a reversible process, therefore some of the analyte can partition back into water if its aqueous concentration decreases significantly over time. Also in this case the result will not accurately reflect the TWA concentration.

So-called semi-permeable membrane devices, or SPMD, are an important class of membrane-based passive samplers for water. Originally developed by Huckins et al. [24], they were used to study the bioavailability of hydrophobic organic chemicals to aquatic organisms. SPMDs proved to be the most effective in their capacity to accumulate lipophilic substances, accurately



reflecting bioconcentration factors in aquatic organisms. They consist of a tubular low-density polyethylene lay-flat membrane filled with about 1 g of high molecular weight lipid, usually high-purity synthetic trioleine. Sampling is driven by lipid-water partitioning.

SPMDs have many advantages, including ease of deployment, standardized character, possibility of using long sampling times (typically 30 days) without approaching equilibrium, and accurate representation of the freely dissolved fraction of the analyte in water. The effective sampling rates for many hydrophobic compounds have been published, which often makes calibration of each device unnecessary. The biggest disadvantage of SPMDs is the complex procedure required to recover the analytes from the trioleine collecting phase. The analytes are recovered through dialysis using non-polar solvents, followed by concentration of the extract and its clean-up. The procedure is quite tedious and takes several days to complete. Nevertheless, SPMDs find widespread applications in water analysis. Interestingly, the use of SPMDs for air analysis is being reported increasingly often.

Supported liquid membrane devices are based on porous PTFE membranes impregnated with an organic solvent and separating the sample from a stripping solution. They are used most often to extract ions from water. While analyte transport through the membrane is driven by the difference in chemical potentials, the sample and the stripping solution are most often forced through channels in a special device, therefore they are not true passive samplers. The principle, however, could be relatively easily applied for passive sampling.

Diffusion-based passive samplers find much less widespread applications in water analysis. They typically use solid sorbents as the collecting medium. In the simplest implementation, a sorbent bed is directly exposed to water. Addition of a well-defined diffusion barrier helps define the sampling rate.



SPME can be considered a variant of diffusion-based passive sampling methods. In fact, whenever the SPME fibre is exposed to water, diffusion-based passive sampling takes place. In laboratory settings, analyte transport is usually enhanced by stirring the sample during sampling. However, SPME devices can also be deployed in the field by exposing them directly to the body of water of interest. Due to the relatively short time required to reach equilibrium, SPME is particularly suited for passive grab sampling. Nilsson et al. [25] used a remotely actuated SPME device to passively sample organic contaminants in groundwater *in situ*.

Solid sampling

Passive sampling of analytes from solid matrices (e.g. soil, bottom sediment, compost) has a relatively short history, with papers devoted to this topic appearing only in recent years. The main obstacle in this case is the difficulty in converting the amount of analyte collected by the sampler to its concentration in the solid matrix. Accurate conversion is often impossible, therefore in most cases passive sampling is used for screening purposes only.

Several different approaches to passive sampling of solids have been proposed in the literature. Probably the most widespread is the application of SPMD [26,27,28,29]. The device can be protected against damage for example by means of stripes of precleaned cotton fabric [26]. Nilsson et al. [25] used a remotely actuated SPME device for soil gas sampling.

So-called PETREX sample collectors consist of activated charcoal adsorbent fused to a ferromagnetic wire in a glass test tube. They are typically buried 30 to 45 cm deep with open end down and left in place from overnight to several weeks [30]. A device based on a similar principle was used for sampling of chloroform from soil [31]. A so-called GORT-SORBER® screening module [32] is a device in which sorbent containers are enclosed inside expanded



tubular PTFE membranes resembling shoestrings. The analytes are usually recovered from the sorbent by thermal desorption.

Applications of Passive Samplers

Table 2 presents main application areas of passive sampling. Overall, this technique is most often used for the determination of time-weighted average concentrations of analytes. Passive sampling is particularly suited for this purpose, because a single device and a single determination are sufficient to yield information on the TWA concentration of the analyte during the entire exposure period. In contrast, grab sampling represents the conditions at the time of sampling only, therefore to accurately determine the TWA concentration it is necessary to collect enough samples to cover the entire period of interest. The number of samples collected in this way can be quite large to gain the same time averaged information. If the samples are not analyzed on-site, it is necessary to use a corresponding number of sampling devices or containers, which can be expensive; besides, the overall cost of the analysis is the product of the cost of a single determination and the number of individual grab samples. Thus, accurate determination of time-weighted average concentrations using grab samples can be prohibitively expensive, especially if the period of interest is long. In addition, by concentrating the analytes on site, passive sampling avoids problems related to changes in the composition of the sample during transport and/or storage. On the other hand, grab sampling is better suited for the detection of short-term changes in analyte concentration.

So far, passive samplers have found numerous applications in the analysis of a wide spectrum of both organic and inorganic compounds in air, as well as in the analysis of organic compounds in

water. The use of passive sampling for the analysis of organic pollutants in soil has also been reported. Table 3 presents a compilation of literature data on selected representative applications of various types of passive samplers. The table is not intended to be comprehensive – its goal is to give the reader an overview of the applications of passive sampling and guide him/her to the appropriate literature.

Biomonitoring

The idea of using living organisms to assess certain characteristics of the environment is not new. Certain plants have been known for centuries to indicate the presence of ores in the ground. In 1866, a study was carried out by Nylander, who assessed air pollution on the basis of lichens composition in Luxembourg. Hydrophobic organic pollutants (e.g. PCBs, PAHs, OCPs, etc.) are strongly lipophilic, and are therefore concentrated in the fat of aquatic organisms. It may happen that they are present at such low levels in water that they cannot be detected by usual chemical procedures, yet they may still have an adverse effect on living organisms due to bioconcentration.

The relationship between the state of the environment and the condition of living organisms makes them useful in assessing environmental pollution. Many organisms fulfil the criteria of passive sampling given at the beginning of this paper, therefore can be considered in effect to be passive samplers. Generally, living organisms can be used in monitoring of environmental pollution in one of two roles: as bioindicators or biomonitors. While there is still some ambiguity regarding these two terms, we believe that the definition given by Markert et al. [33] is clear and relevant. According to this definition, bioindicators and biomonitors are organisms or communities of organisms whose content of certain elements or compounds and/or whose morphological, histological or cellular structure, metabolic-biochemical processes, behaviour or

population structure(s), including changes in these parameters, deliver information on the quality of the environmental changes or the quantity of the environmental pollutants (or their changes), respectively. Thus, the difference between bioindicators and biomonitors is the type of information they deliver, qualitative vs. quantitative.

Living organisms as samplers have certain unquestionable advantages. They reflect the true impact of the condition of the environment. In most cases (when native species are used) they do not need to be deployed before the actual measurement. They usually concentrate the pollutants, sometimes to a very large extent, which facilitates their determination. Finally, in most cases they cost nothing. On the other hand, to be useful, they need to fulfil certain criteria [34]. For example, they should have resident character – migratory species do not reflect the pollutant levels at any particular location. They should be widely distributed over the examined area, and easy to collect. To assure long-term monitoring, the population should be stable. There should be a correlation between the degree of pollution and the level of the pollutant in the organisms, and the concentration factor should be the same at different sites. Finding organisms that fulfil all of the criteria can sometimes be difficult. Table 4 presents a classification of passive techniques used in environmental biomonitoring. More detailed information can be found in numerous papers, e.g. [11,34,35,36,37].

Summary

In spite of its relatively long history, passive sampling is still a developing area. It has many significant advantages, including simplicity, low cost, no need for expensive and sometimes complicated equipment, no power requirements, unattended operation, and the ability to produce accurate results. There are also some limitations that may sometimes be difficult to overcome,



probably the most important of which is the possible effect of environmental conditions (temperature, air movement, humidity, etc.) on the analyte uptake. In spite of such concerns, many users find passive sampling an attractive alternative to more established sampling procedures. To gain more general appeal, however, broader regulatory acceptance would probably be required.

Passive sampling is most often used for the determination of time-weighted average concentrations. The response time of the samplers in such studies is dictated by the length of the period studied. Once the measurement session is completed, however, passive sampling very often significantly simplifies further steps in the analytical procedure, as it generally combines sampling and sample preconcentration into a single step. Thus, with a few exceptions, passive sampling shortens the time between sample collection and analysis, improving the response time of the entire system. It is also possible to apply passive techniques for grab sampling, in which case the response time of the analytical system can be very short compared to other techniques. Overall, we believe that the full potential of passive sampling techniques is not yet fully utilized. Hopefully, this will change in not-so-distant future.

Acknowledgements

Financial support of the Natural Sciences and Engineering Research Council of Canada is gratefully acknowledged. The authors would also like to thank B. Zabiegała for preparing the figures for this paper.



Figure Captions

Figure 1. Schematic diagram of: (A) tube-type diffusion sampler, and (B) badge-type permeation sampler.

Figure 2. SPME used in time-weighted average sampling mode. A – cross section area of the needle opening, L – length of diffusion path.

Figure 3. Example of a design of a badge-type passive sampler for air sampling. 1 – upper nut, 2 – washer, 3 – membrane, 4 – protective screen, 5 – washer, 6 – main body, 7 – o-ring, 8 – bottom cap, 9 – opening for screw-in holder, 10 – set screw, 11 – sorbent, 12 – quartz wool.

Figure 4. Examples of the design of commercially available passive samplers for gas sampling. The top sampler is designed for thermal desorption of the analytes. The bottom sampler is equipped with a built-in desorption chamber.

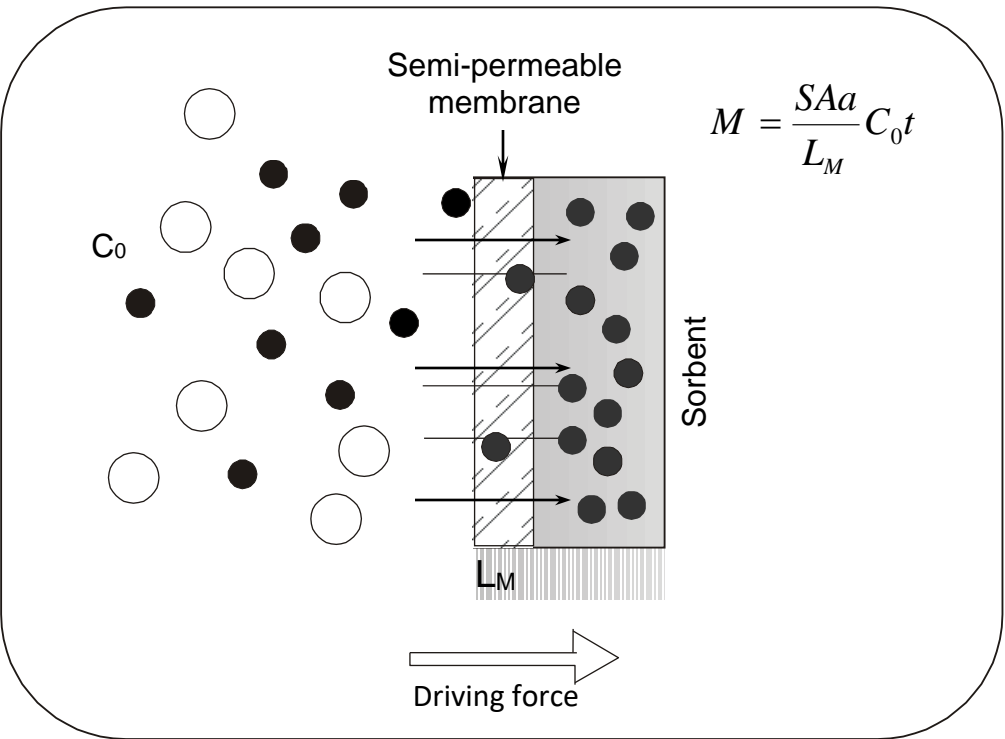
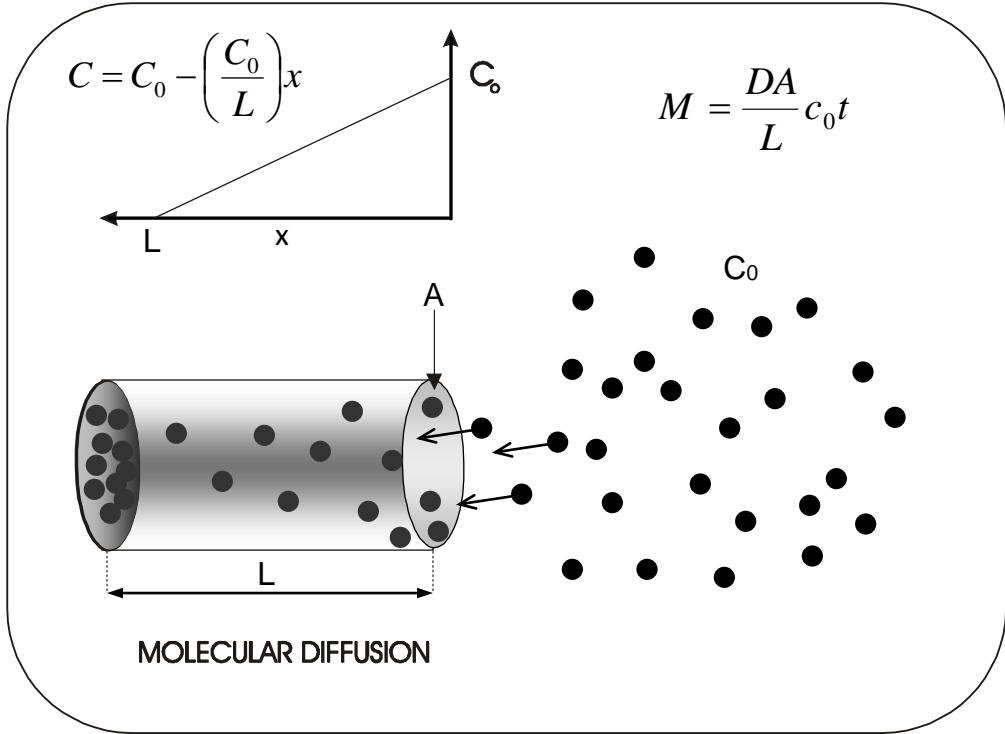

Figure 1

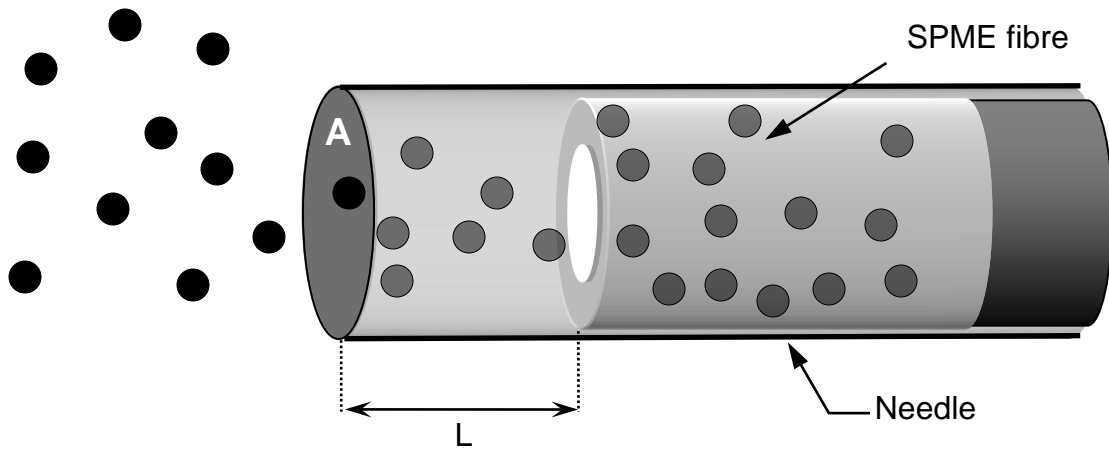

Figure 2

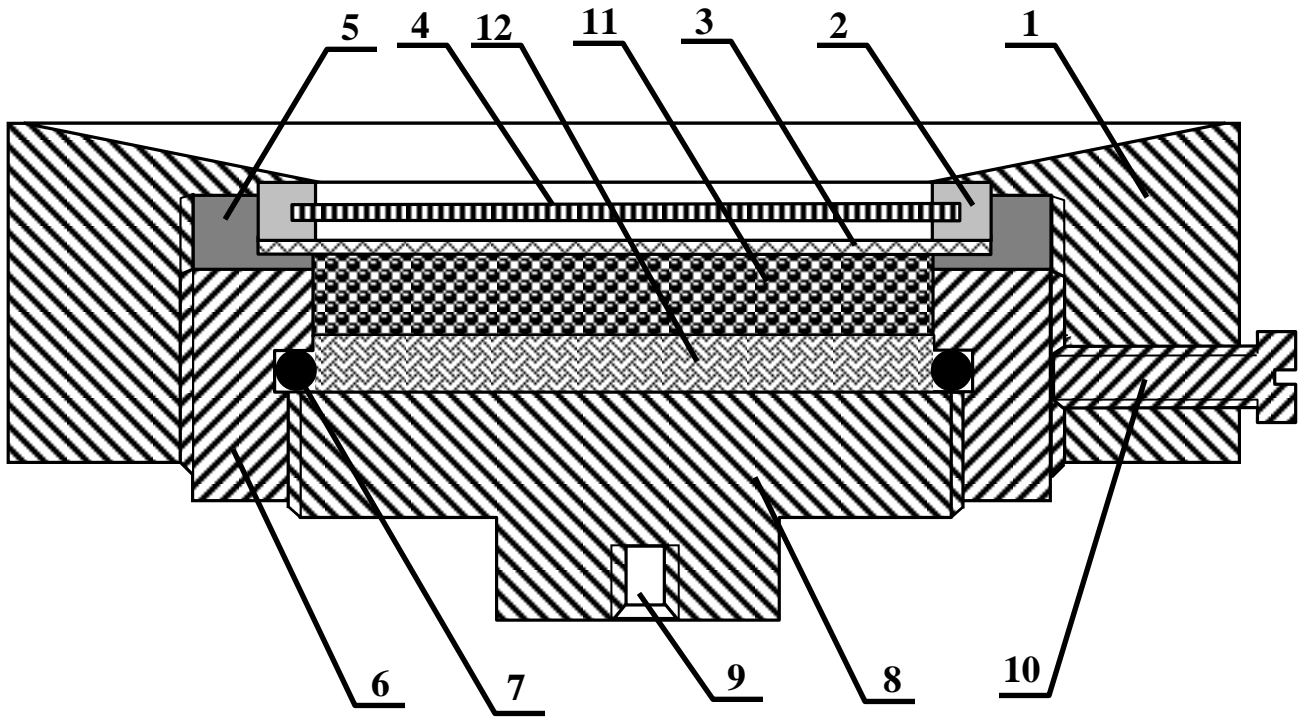
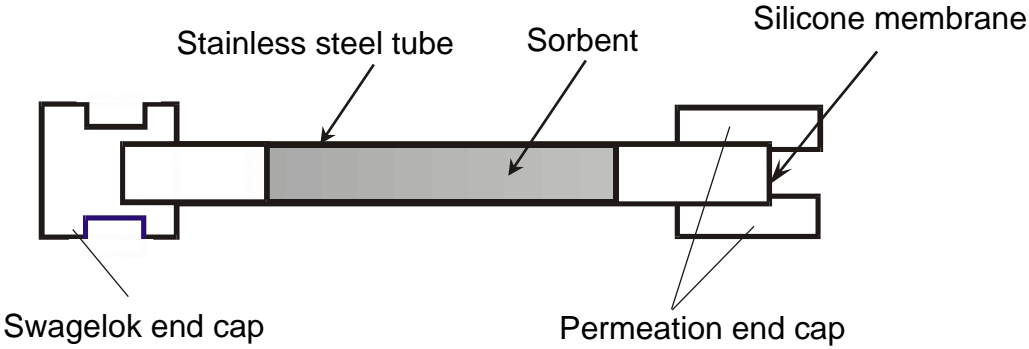

Figure 3

PERKIN ELMER SAMPLER



SKC BADGE PASSIVE SAMPLER

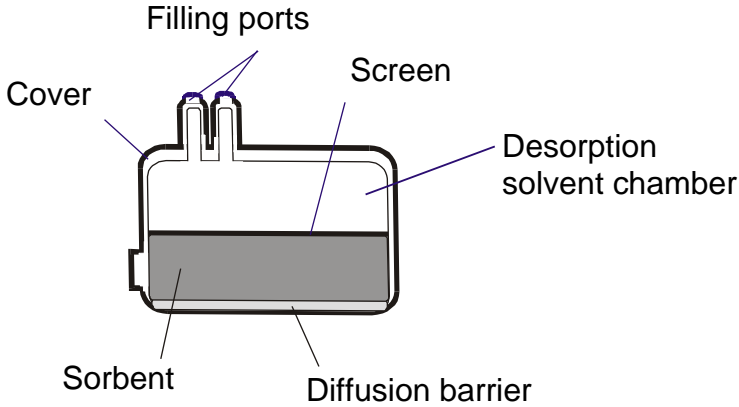

Figure 4

Table 1. Classification of passive sampling techniques

No.	Classification parameter	Characteristics	Type of passive device
1.	Medium used for sampling	Dedicated device incorporating a trapping medium	<ul style="list-style-type: none"> • Passive samplers • Solid phase microextraction (SPME) fibre • Semipermeable membrane device • Single solvent droplet
		Living organisms	<ul style="list-style-type: none"> • Bioindicators • Biomonitors
2.	Sample type	<ul style="list-style-type: none"> • Gaseous <ul style="list-style-type: none"> - atmospheric air - indoor air - workplace atmosphere 	<ul style="list-style-type: none"> • Passive samplers • SPME • Bioindicators • Biomonitors
		<ul style="list-style-type: none"> • Liquid <ul style="list-style-type: none"> - Surface waters - Potable water 	<ul style="list-style-type: none"> • Passive samplers • SPMD • SPME • Bioindicators • Biomonitors
		<ul style="list-style-type: none"> • Solid <ul style="list-style-type: none"> - Soil 	<ul style="list-style-type: none"> • Passive samplers • SPME
3.	Type of analytical information acquired	<ul style="list-style-type: none"> • Long-term time weighted average (TWA) concentration 	Area monitors
		<ul style="list-style-type: none"> • Individual exposure • Peak concentration • 8 hr. average concentration 	Personal samplers
4.	Manner in which analytical information is acquired	<ul style="list-style-type: none"> • Observation of living organisms 	Bioindicators
		<ul style="list-style-type: none"> • Determination of the amount of analyte collected by the sampler 	<ul style="list-style-type: none"> • Passive samplers • SPME • Biomonitors

Table 2. Main application areas of passive sampling.

Medium	Sample type	Measurement goals
Gaseous	Atmospheric air	Determination of time-weighted average concentrations over long periods of time (area monitors)
	Indoor air	Determination of time-weighted average concentration ----- Determination of momentary concentration (grab sampling by Solid Phase Microextraction)
	Workplace air	Determination of 8-hr time-weighted average concentration ----- Determination of personal exposure (personal dosimeters)
Liquid	Surface waters	Determination of time-weighted average concentrations over long periods of time ----- Determination of momentary concentration (grab sampling by Solid Phase Microextraction)
Solid	Soil	Determination of volatile organic compounds

Table 3. Selected applications of passive samplers.

Inorganic compounds		Organic compounds
Air		
Carbon monoxide [38]	CO	Aliphatic hydrocarbons (C ₅ - C ₁₂) [16,39,40,41,42,43,44]
¹⁴ Carbon dioxide [45]	¹⁴ CO ₂	Aromatic hydrocarbons (benzene, toluene, xylenes, etc.) [39,40,41,43,46,47,48,49,50,51,52,53,54]
Nitrogen oxides [55,56,57,58,59]	N _x O _y	Non-methane Organic Compounds [60]
Ammonia [61,62]	NH ₃	Chlorinated hydrocarbons (trichloroethylene, tetrachloroethylene, etc.) [39,46,49,50,63,64,65,66]
Chlorine [67]	Cl ₂	Microbial Volatile Organic Compounds (MVOCs) [68]
Chlorine dioxide [67]	ClO ₂	Amines (methylamine, dimethylamine, isopropylamine, diethylamine, butylamine) [69]
Sulphur dioxide [62,70]	SO ₂	Perfluorinated hydrocarbons [71,72]
Hydrogen sulphide [56,73,74]	H ₂ S	Petroleum hydrocarbons (38 components) [75]
Carbon disulphide [76]	CS ₂	Monoterpenes (α -pinene, β -pinene, Δ^3 -carene) [77,78]
Ozone [79,80]	O ₃	Styrene and its derivatives (α -methylstyrene, o-chlorostyrene, styrene-7,8-oxide) [81,82,83,84]
Hydrogen fluoride [85]	HF	Polychlorinated biphenyls [86,87]
Hydrogen cyanide [74]	HCN	Formic and acetic acids [88]
Arsenium hydride [66]	AsH ₃	Aldehydes (formaldehyde, acetaldehyde, glutaraldehyde) [19,89,90,91,92,93]
Mercury [94]	Hg	1,3-butadiene [95]
²²² Radon [96,97]	²²² Rn	Isoprene [98]
Dust [99,100]		Polyaromatic pollutants [101]
		Dioxane [39]
		Naphthalene [43]
		Gasoline oxygenates (MTBE, TBEE, TAME) [102,103]
		Vinyl chloride [46,63]
		Acetates [39,44]
		Alcohols [39,43,44]
		Acetone [39]
		Ketones (methyl-ethyl, methyl-isobutyl, etc.) [39,44,83,104]
		Tetraethyllead [74]
		Acrylonitrile [49]
		Ethylene oxide [105]
		Halothane, enflurane and isofluranes (anaesthetics) [66,106]
		Reactive gases in atmospheric air (1-pentene, isoprene, 1-hexene) [107]



	<p>Hydrazines (hydrazine, methyl hydrazine, dimethyl hydrazine) [108]</p> <p>3-ethenylpyridine (marker for environmental tobacco smoke) [109]</p> <p>Fungal spores [110]</p> <p>Polychlorinated aromatic hydrocarbons [111]</p>
Water	
Inorganic sulfur compounds [112]	<p>Pesticides [113,114]</p> <p>Volatile organic compounds [115]</p> <p>Organotin compounds [116]</p> <p>Persistent organic pollutants (POP) [117]</p> <p>Dioxins [114]</p> <p>PCBs [27,114]</p> <p>HCB [27,114]</p> <p>Chlorophenols [27]</p> <p>Biocides [118]</p> <p>Polycyclic aromatic hydrocarbons (PAH) [119,120,121,122]</p> <p>Toxicity [28]</p>
Soil	
Inorganic sulfur compounds [112]	<p>Volatile organic compounds [123]</p> <p>Trichloroethylene [124]</p> <p>Chloroform [31]</p> <p>Toxicity [28]</p> <p>Polycyclic aromatic hydrocarbons [125]</p> <p>Organochlorine pollutants in compost [29]</p>



Table 4. Classification of passive techniques used in environmental biomonitoring

No.	Classification parameter	Description	Additional comments
1.	Species	<ul style="list-style-type: none"> • Mosses • Lichens • Grasses • Algae • Trees • Vegetables • Mussels • Fish • Animal tissue, fluids and organs • Human tissue and fluids (hair, nails, saliva, tears, urine, blood, sperm, adipose tissue, etc.) 	
2.	Origin of organism	<ul style="list-style-type: none"> • Local organisms • Transplanted organisms 	
3.	Type of analytical information acquired	Qualitative information	Bioindicators
		Quantitative information	Biomonitors
4.	Manner in which analytical information is acquired	<ul style="list-style-type: none"> • Chemical analysis of tissue and organ samples of living organisms • Evaluation of the condition of the environment based on: <ul style="list-style-type: none"> - examination of aerial and satellite photographs, - observation of the behaviour and responses of living organisms - diatomite analysis - pollen analysis • Prognostication <ul style="list-style-type: none"> - Blooms - Ecological succession 	
5.	Mode of action	<ul style="list-style-type: none"> • Determination of the levels of elements and/or chemical compounds in living organisms 	Accumulation monitors/indicators

		<ul style="list-style-type: none"> • Examination of the effects of exposure to certain elements and/or chemicals: <ul style="list-style-type: none"> - Morphological, histological or cellular changes, - Metabolic changes, - Behavioural changes, - Changes in the population structure 	<p>Exposure monitors/indicators</p>
--	--	---	-------------------------------------

References

1. W.K. Fowler: Intern. Lab., Dec. 1982, 80.
2. V.E. Rose, J.L. Perkins: Am. Ind. Hyg. Assoc. J. 43 (1982) 605.
3. J. Namieśnik, T. Górecki, E. Kozłowski, L. Torres, J. Mathieu, Sci. Total. Environ. 38 (1984) 225.
4. X.L. Cao, C.N. Hewitt, Environ. Technol. 12 (1991) 1055.
5. R.H. Brown: Pure Appl. Chem. 65 (1993) 1859.
6. B. Kozdroń-Zabiegała, J. Namieśnik, A. Przyjazny, Indoor Environ. 4 (1995) 189.
7. J. Namieśnik, T. Górecki, LC-GC Europe 13(9) (2000) 678.
8. C.S. Gordon, J.T. Lowe, U.S. Patent 1,644,014 (1927).
9. E.D. Palmes, A.F. Gunnison: Am. Ind. Hyg. Assoc. J. 34 (1973) 78.
10. K.D. Reiszner, P.W. West: Environ. Sci. Technol. 7 (1973) 526.
11. A. Kot, B. Zabiegała, J. Namieśnik, TrAC 19(7) (2000), 446.
12. B. Zabiegała, A. Kot, J. Namieśnik, Chem. Anal. (Warsaw) 45 (2000), 645.
13. A. Bailey, P.A. Hollingdale-Smith, „Passive Sampling and Dosimetry”, in: E. Reid (ed.), Trace Organic Sample Handling, Horwood, Chichester, 1981, p.45.
14. G. Bertoni, S. Canepari, M. Rotari, C. Perrino, R. Fratarcangeli, A. Liberti, J. Chromatogr. 522 (1990) 285.
15. J. Pawliszyn, “Solid Phase Microextraction. Theory and Practice”, Wiley-VCH, New York, NY, 1997.
16. P.A. Martos, J. Pawliszyn, Anal. Chem. 71 (1999) 1513.
17. A. Khaled, J. Pawliszyn, J. Chromatogr. 892 (2000) 455.
18. P.A. Martos, J. Pawliszyn, Anal. Chem. 70 (1998) 2311.
19. J.A. Koziel, J. Noah, J. Pawliszyn, Environ. Sci. Technol. 35 (2001) 1481.
20. J.A. Koziel, J. Pawliszyn, J. Air and Waste Manag. Assoc. 51 (2001) 173.
21. A. Södergren, Environ. Sci. Technol. 21 (1987) 855.
22. A. Kot, A. Wasik, Proc. V International Symposium ‘Chemistry Forum ‘99’, 19-21 April, Warsaw, Poland, p. 94.
23. S. Litten, B. Mead, J. Hasset, Environ. Toxicol. Chem. 12 639 (1993).
24. J.N. Huckins, M.W. Tubergen, G.K. Manuweera, Chemosphere 20 (1990) 533.
25. T. Nilsson, L. Montanarella, G. Baglio, R. Tilio, G. Bidoglio, S. Facchetti, Intern. J. Environ. Anal. Chem. 69(3) (1998) 217.
26. J. Caslavsky, Z. Zdrahal, M. Vytopilovu, Polycyclic Aromat. Compds. 20 (2000) 123

-
27. A. Granmo, R. Ekelund, M. Berggren, E. Brorstrom-Lunden, P.A. Bergvist, *Environ. Sci. Technol.*, 34 (2000) 3323.
 28. B.T. Johnson, J.N. Huckins, J.D. Petty, R.C. Clark, *Environ. Toxicol.* 15 (2000) 248.
 29. B. Strandberg, N. Wagman, P.A. Bergvist, P. Haglund, Ch. Rappe, *Environ. Sci. Technol.* 31 (1997) 2960.
 30. M. Anderson, G. Church, *J. Environ. Eng.* 124 (1998) 555.
 31. E.J. Hoekstra, J. H. Duyzer, E.W.B. de Leer, V.A.Th. Brinkman, *Atmos. Environ.*, 35 (2001) 61.
 32. H. Stolpman, L. Deyerling, Ch. Mehlretter, H. Sorge, *Proc. Int. Conf. "Analysis and utilisation of oily wastes"* September 8-12, 1996, Gdansk, p 1-6.
 33. B. Markert et al., *ASC Symp. Ser.* 654 (1997) 18.
 34. W.J. Langston, S.K. Spence, Biological factors involved in metal concentrations observed in aquatic organisms. In: *Metal speciation and bioavailability in aquatic systems* (Ed. A. Tessier and D.R. Turrier), J. Wiley and Sons Ltd., 1995, p. 407.
 35. J. Namieśnik, W. Wardencki, *Herba Polonica* 46(4) (2000) 198.
 36. L. Campanella, P. Ercole, *Pure Applied Anal. Chem.* 1 (1998) 87.
 37. M.A. Mora, S.E. Wainwright, *Rev. Environ. Contam. Toxicol.* 158 (1996) 1.
 38. K. Lee, Y. Yanagisawa, M. Hishinuma, J.D. Spengler, I.H. Billick, *Environ. Sci. Technol.* 26 (1992) 697.
 39. S.T. Rodriguez, D.W. Gosselink, H.E. Mullins, *Am. Ind. Hyg. Assoc. J.* 43 (1982) 569.
 40. M. De Bortoli, H. Knöppel, E. Pecchio, H. Vissers, *Environ. Int.* 15 (1989) 427.
 41. J.L.S. Hickey, C.C. Bishop, *Am. Ind. Hyg. Assoc. J.* 42 (1981) 264.
 42. N. Kilic, J. A. Ballantine, *Analyst* 123 (1998) 1795.
 43. V.M. Brown, D.R. Crump, D. Gardiner, *Environ. Technol.* 13 (1992) 367.
 44. R.L. Bamberger, G.G. Esposito, B.W. Jacobs, G.E. Podolak, J.F. Mazur, *Am. Ind. Hyg. Assoc. J.* 39 (1978) 701.
 45. M.J. Wood, R.A. Surette, J.K. Mohindra, J.G. Patterson, *Health Phys.* 74 (1998) 253.
 46. J. Perkins, *Ann. Am. Conf. Gov. Ind. Hyg.* 1 (1981) 125.
 47. N. Van Den Hoed, M.T.H. Halmans, *Am. Ind. Hyg. Assoc. J.* 48 (1987) 364.
 48. W.J. Lautenberger, E.V. Kring, J.A. Morello, *Am. Ind. Hyg. Assoc. J.* 41 (1980) 737.
 49. R.W. Contant, R.G. Lewis, J.D. Mulik, *Anal. Chem.* 58 (1986) 445.
 50. J. Begerow, E. Jermann, T. Keles, U. Ranft, L. Dunneman, *Fresenius J. Anal. Chem.* 351 (1995) 549.
 51. A. Gelencser, Gy. Kiss, J. Hlavay, Th.L. Hafkenschied, R.J.B. Peters, E.W.B. de Leer, *Talanta* 41 (1994) 1095.

-
52. V.M. Brown, D.R. Crump, D. Gardiner, C.W.F. Yu, *Am. Ind. Hyg. Assoc. J.* 52 (1991) 151.
 53. M.D. Wright, N.T. Plant, R.H. Brown, *Environ. Monit. Assess.* 52 (1998) 57.
 54. B. Zabiegała, J. Namieśnik, E. Przyk, A. Przyjazny, *Chemosphere* 39 (1999) 2035.
 55. O. Royest, *Fresenius J. Anal. Chem.* 360 (1998) 69.
 56. F.C. Tompkins, R.L. Goldsmith, *Am. Ind. Hyg. Assoc. J.* 38 (1997) 371.
 57. A.J. Gair, S.A. Penkett, *Atmos. Environ.* 29 (1995) 2529.
 58. E.D. Palmes, C. Tomczyk, *Am. Ind. Hyg. Assoc. J.* 40 (1979) 588.
 59. M. Mangartner, *VDI Berichte* 838 (1990) 515.
 60. P.V. Doskey, H.M. Bialk, *Environ. Sci. Technol.* 35 (2001) 581.
 61. M. Kirchner, S. Braeutigam, M. Ferm, M. Mangartner, P. Hofschreuder, A. Kasper-Giebl, H. Rommelt, J. Streidner, W. Terzer, W. Werner, R. Zimmerling, *J. Environ. Monit.* 1 (1999) 259.
 62. M. Kirchner, *Sonderdruck aus Watter und Leben* 49 (1997) 191.
 63. L.H. Nelms, K.D. Reiszner, P.W. West, *Anal. Chem.* 49 (1977) 994.
 64. R.G. Lewis, J.D. Mulik, R.W. Contant, G.W. Wooten, C.R. Mc Millin, *Anal. Chem.* 57 (1985) 214.
 65. T.A. Olansandan, H. Matsushita, *Talanta* 50 (1999) 855.
 66. R.H. Brown, P.C. Cox, C.J. Purnell, N.G. West, M.D. Wright, The applicability of passive sampling technique to the analysis of specific vapors in air. In: *Identification and analysis of organic pollutants in air* (eds. L.H. Keith) Butterworth Publ., Boston, Toronto, 1984, p.37.
 67. E. Bjorkholm, A. Hultmann, J. Rudling, *Appl. Occup. Environ. Hyg.* 5 (1990) 767.
 68. K. Elke, J. Begerow, H. Oppermann, U. Karmer, E. Jermann, L. Dunemann, *J. Environ. Monit.* 1 (1999) 445.
 69. R. Lindahl, J.O. Levin, K. Andersson, *J. Chromatogr.* 643 (1993) 35.
 70. B.A. Sceeren, F. De Santis, I. Allegrini, P. Heeves, *Intern. J. Environ. Anal. Chem.* 56 (1994) 73.
 71. A.G. Straume, R.N. Dietz, E. N'dri Koffi, K. Nodop, *Atmos. Environ.* 32 (1998) 4109.
 72. C. Yost, M. Harper, *Appl. Occup. Environ. Hyg.* 15 (2000) 165.
 73. D. Shooter, S.F. Watts, A.J. Hayes, *Environ. Monit. Assess.* 38 (1995) 11.
 74. P.W. West, *Am. Lab.* 12 (1980) 35.
 75. J.T. Purdham, A.M. Sass-Kortsak, P.R. Bozek, *Ann. Occup. Hyg.* 38 (1994) 721.
 76. S. Tanaka, T. Yamauchi, T. Takebayashi, K. Omae, Y. Seki, *Ind. Health* 35 (1997) 474.
 77. K. Eriksson, J.O. Levin, M. Rhen, R. Lindahl, *Analyst* 119 (1994) 85.
 78. A.L. Sunesson, M. Sundgren, J.O. Levin, K. Eriksson, R. Carlson, *J. Environ. Monit.* 1 (1999) 45.



-
79. L.J.S. Liu, P. Kourakis, H.H. Suh, J.D. Mulik, R.M. Burton, *Environ. Health Perspect.* 101 (1993) 318.
 80. P. Koutracis, J.M. Wolfson, A. Bunyaviroch, S.E. Froehlich, K. Hirano, J.D. Mulik, *Anal. Chem.* 65 (1993) 209.
 81. A. Bailey, P.A. Hollingdale-Smith, *Ann. Occup. Hyg.* 20 (1977) 345.
 82. M. Harper, D.L. Fiorito, *Appl. Occup. Environ. Hyg.* 11 (1996) 1238.
 83. M. Evans, M. Molyneux, T. Sharp, A. Bailey, P. Hallingdale-Smith, *Ann. Occup. Hyg.* 20 (1977) 357.
 84. R. Tornero-Velez, S. Waidyanatha, D. Echeverria, S.M. Rappaport, *J. Environ. Monit.* 2 (2001) 111.
 85. N. Kalinic, *Med. Lav.* 83 (1992) 274.
 86. N. Wagman, B. Strandberg, M. Tysklind, *Organohalogen Compds.* 35 (1998) 209.
 87. W.A. Ockenden, H.F. Prest, G.O. Thomas, A. Sweetman, K.C. Jones, *Environ. Sci. Technol.* 32 (1998) 1538.
 88. B.J. Johnson, S.C. Huang, A. Wong, L. Yao, *Microchim. J.* 49 (1994) 78.
 89. Ch. Muntuta-Kinyanta, J.K. Hardy, *Talanta* 38 (1991) 1381.
 90. Y. Mori, S. Setsuda, S. Gots, S. Onodera, S. Nakai, H. Matsushita, *J. Health Sci.* 45 (1999) 105.
 91. J.S. Noble, Ch.R. Strang, P.R. Michael, *Am. Ind. Hyg. Assoc. J.* 54 (1993) 723.
 92. R. Lindahl, J.O. Levin, M. Martensson, *Analyst* 121 (1996) 1177.
 93. R. Lindahl, J.O. Levin, *J. Chromatogr.* 710 (1995) 175.
 94. Ch.S. Mc Common, J.W. Woodfin, *Am. Ind. Hyg. Assoc. J.* 38 (1977) 378.
 95. Ch. Yao, D.C. Krueger, K.R. Loos, J.W. Koehn, *Am. Ind. Hyg. Assoc. J.* 58 (1977) 48.
 96. M. Urban, J. Schmitz, H. Kiefer, *Radiat. Protect. Dosimetry* 45 (1992) 729.
 97. J.A. Gunby, S.C. Darby, J.C.H. Miles, B.M.R. Green, D.R. Cox, *Health Phys.* 64 (1993) 2.
 98. X.L. Cao, C.N. Hewitt, *Atmos. Environ.* 27A (1993) 1865.
 99. R.C. Brown, M.A. Hemingway, D. Wake, A. Thorpe, *Analyst* 121 (1996) 1241.
 100. R.C. Brown, A. Thorpe, M.A. Hemingway, *Environ. Monit. Assess.* 52 (1998) 19.
 101. T. Vo-Dinh, *Environ. Sci. Technol.* 19 (1985) 997.
 102. M. Harper, Ch. O'Lear, A.A. Fiore, *Analyst* 121 (1996) 1265.
 103. P.H. Fellin, Ch. Geen, R. Otson, D.T. Williams, R. Westerholm, *Meas. Toxic Relat. Air Pollut., Proc. Spec. Conf.* 1 (1998) 538, *Air and Waste Manag. Assoc.*, Pittsburgh, PA.
 104. S. Uchiyama, S. Hasegawa, *Atmos. Environ.* 33 (1999) 1999.
 105. F.G. Szopiński, M.A. Puskar, L.H. Hecker, *Am. Ind. Hyg. Assoc. J.* 52 (1991) 151.



-
106. C. Prado, F. Periago, I. Ibarra, J. Tortosa, J. Chromatogr. 657 (1993) 131.
 107. X.L. Cao, C.N. Hewitt, J. Chromatogr. 648 (1993) 191.
 108. S.L. Rose-Pehrsson, J.R. Wyatt, K.P. Brenner, P.T. Carver, S.W. Brown, A.R. Thurow, J.C. Travis, Am. Ind. Hyg. Assoc. J. 55 (1994) 149.
 109. S. Vainiotalo, R. Vaaranrinta, J. Tornaesus, N. Aremo. T. Hase, K. Peltonen, Environ. Sci. Technol. 35 (2001) 1818.
 110. A. Nasman, G. Blomquist, J.O. Levin, J. Environ. Monit. 1 (1999) 361.
 111. J.M. Mueller, D.W. Hawker, D.W. Connell, P. Komp, M.C. McLachlan, Atmos. Environ. 34 (2000) 3525.
 112. G.A. Ulrich, L.R. Krumholz, J.M. Suflita, Appl. Environ. Microbiol. 63 (1997) 1627.
 113. M. Muschal, Australas. J. Ecotoxicol. 5 (1999) 141.
 114. L.R. Zimmermann, E.M. Thurman, K.C. Bastian, The Univ. Kansas Cent. For Res., Inc., Lawrence, KS, USA, Water-Resour. Invest. Rep. (US Geol. Surv.), Geological Survey Toxic Substances Hydrology Program, 2 (1999).
 115. J. Tunks, P. Guest, J. Santillan, Risk, Regul., Monit. Consid.: Rem. Chlorinated Recalcitrant Compd., Int. Conf., 2nd (2000), p. 369, Batelle Press, Columbus, OH.
 116. N. Folsvik, E. Brevik, J.A. Berge, J. Environ. Monit. 2 (2000) 281.
 117. L.R. Zimmerman, E.M. Thurman, K.C. Bastian, Sci. Total Environ. 248 (2000) 169.
 118. J.K. Kingston, R. Greenwood, G.A. Mills, G.M. Morrison, L.B. Persson, J. Environ. Monit. 2 (2000) 487.
 119. T. I. Roe Utvik, G.S. Durell, S. Johnsen, Marine Pollut. Bull. 38 (1999) 977.
 120. J.N. Huckins, J.D. Petty, C.E. Orazio, J.A. Lebo, R.C. Clark, V.L. Gibson, W.R. Gala, K.R. Echols, Environ. Sci. Technol. 33 (1999) 3918.
 121. K.E. Gustavson, W.M. De Vita, A. Revis, J.M. Harkin, J. Chromatogr. 883 (2000) 143.
 122. K.E. Gustavson, J.H. Harkin, Environ. Sci. Technol. 34 (2000) 4445.
 123. A.D. Hewitt, Field Anal. Methods Hazard. Wastes Toxic Chem., Proc. Spec. Conf. (1997), p. 393, Air and Waste Management Association, Pittsburgh, PA.
 124. A.D. Hewitt, Am. Environ. Lab. 10 (1998) 14.
 125. B.A. Scamoffa, J.P. Cusick, R. Leckenwalter, Environ. Sci. Res., 51 (1996) 389.

