

Leon SWĘDROWSKI

GDAŃSK UNIVERSITY OF TECHNOLOGY, FACULTY OF ELECTRICAL AND CONTROL ENGINEERING, DEPARTMENT OF ELECTRICAL MEASUREMENT

Measurements and Analysis of Motor Supplying Current Waveform for Diagnostic Purposes

Dr inż. Leon SWĘDROWSKI

He received the M.S. degree from Gdansk University of Technology, Gdansk, Poland in 1972. and the Ph.D. degree also from Gdansk University of Technology in 1980, both in electrical engineering. Following the receipt of the M.S. degree he joined the Faculty of Electrical Engineering, Gdansk University of Technology. Since then he is working in the Chair of Electrical Measurements, at present holding the post of an Assistant Professor. His main areas of interest and experience are measurements of non-electrical quantities, technical diagnostics, high-accuracy measurement techniques.

lswed@ely.pg.gda.pl

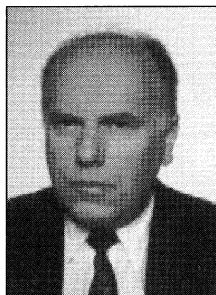

Abstract

The object of the investigation presented in the paper are measurements related to diagnostics of induction motors, specially damages caused to bearings. Due to the fact that the amplitude of the network voltage fundamental harmonic in the supplying current spectrum is high in comparison with harmonic components responsible for damages of bearings, there has been proposed a preliminary elimination of this component from the analog current signal. The proposed filter is shown in the paper. The paper presents also the measuring system and provides results of the investigations carried out on motor encumbered with specially prepared bearing defect.

Streszczenie

Pojawienie się określonych typów uszkodzeń w silniku jest źródłem odkształcenia prądu zasilającego. W przypadku uszkodzenia łożyska amplitudy składowych harmonicznnych w widmie prądu zasilającego maszynę indukcyjną w stosunku do amplitudy składowej podstawowej są bardzo małe w porównaniu z dominującą składową sieciową. Stwarza to problemy z pomiarem składowych harmonicznnych. Dlatego zaproponowano stłumienie składowej sieciowej jeszcze w części analogowej systemu pomiarowego a następnie wzmocnienie pozostałego sygnału.

Ponadto należało określić zależności teoretyczne, opisujące zmiany w prądzie przy określonych rodzajach uszkodzeń. To zadanie rozwiązano budując modele matematyczne silnika indukcyjnego tak skonstruowane, aby były wrażliwe na wprowadzanie zakłóceń, symulujących założone rodzaje uszkodzeń.

Celem pracy było zaprojektowanie i badania systemu pomiarowego, który umożliwiłby pomiary składowych widma prądu silnika indukcyjnego odpowiedzialnych za uszkodzenia łożysk i jego badania.

Rezultaty badań wskazują, że zastosowanie filtra wąskopasmowego, który redukuje składową sieciową, pozwalają na ujawnienie składowych widma, które w zastosowaniu praktycznym są użyteczne - niosą informacje o stanie diagnozowanego obiektu.

Keywords: motor, current spectrum, filters, diagnostics

Słowa kluczowe: silnik, widmo prądu, filtry, diagnostyka

1. Introduction

Present-day problems of technical diagnostics are connected with great measuring complexity accompanying the diagnostic tests, and also with some difficulty to put an interpretation on the results, which requires treatment of the signals measured to obtain some definite diagnostic information.

There are a number of diagnostic methods such as: vibration measurements, flux measurements, temperature measurements which enable to estimate the technical working condition of an induction motor.

The sphere of interest of the author is diagnostics of induction motors using spectral analysis for measuring the motor supplying

current. This procedure enables to find out the following failures in an induction motor:

- faulty winding,
- damage to bearings,
- other mechanical defects.

The occurrence of a certain type of motor failures can result in distortion of the supplying current. In the case of damage to the motor's winding, the supply current spectrum carries data related to frequency components giving information about the existence of the failure. Unlike faults in winding, mechanical defects, e.g. a defect in a bearing, the problem is different. The spectrum of the current supplying the induction machine also reveals components that signaling such a damage. The amplitudes of these components are very small in comparison with the dominated network harmonic component, in particular, at the outset of the failure growth. This creates some problems connected with the measurement of the harmonic components. In order to find a solution, it has been proposed that the network component will be reduced already in the analog part of the system and that the remaining signal will be next amplified and subjected to spectral analysis.

Moreover, it is necessary to determine the theoretical relationships that describe current waveform variations related to specific types of failures.

In the paper [1] there are suggested frequencies connected with bearings faults according to formulas:

$$f_s = |f_n \pm 1 \times f_x| \quad (1)$$

$$f_s = |f_n \pm 2 \times f_x| \quad (2)$$

where: f_s - component of current spectrum, f_n - the frequency of supply network, f_x - the frequency of vibration connected with defined fault of bearing, known from mechanic theory.

Special mathematical model of the object was created for induction motor diagnostics by current measurements and analysis [2, 3, 4]. The simulations for defined types of bearing's faults were carried out on the model. The results of the simulations are similar to the results obtained in the paper [1].

The following conclusions can be drawn from tests performed on the model:

- all frequency components present in the spectrum of a motor with a centric rotor can be modulated with a frequency of f_w and $2f_w$ (and its multiples), where f_w is the frequency of oscillations of the air gap,
- the amplitudes of information-carrying spectrum components appear in the range from -60 to -85 decibels with respect to the fundamental frequency of 50 Hz, when the frequency range is 20-3000 Hz. Values are defined as a relation between measured components and main net component of amplitude 10 V,
- the simultaneous occurrence of static and dynamic eccentricity (which is real in a motor with damaged bearing) results in a high congestion of spectral lines. The components which carry diagnostic information will be in such a situation difficult to detect.

2. The diagnostic system

The following assumptions for creating the measurement system were chosen:

- for conserving the necessary distance between the signal and noise of the system, the total noise of the system should not

exceed -105 dB and the range of measured frequencies should be of 20 Hz - 3 kHz,

- to insure flexibility, the possibility of extension of software and further automatization of measurements, the measurement system should be computerized, based on virtual instruments. In the future, such computerized system deprived of stationary equipment will allow field tests.

For realisation of computer measurement system, the hardware produced by National Instruments and software environment LabVIEW [5, 6] of the same producer were chosen. The tests were carried out to determine the usefulness of data acquisition cards with A/D converters of 12 and 16 bit. Because of decidedly better noise characteristics, for further works there was chosen the card type NI6052E, with 16-bit converter.

National Instruments gives the following figure for appraising the accuracy of measurement performed with data acquisition cards:

$$A_a = \pm [(U_{in} * P_r) + (O + D + N + Q)] \quad (3)$$

where: A_a - Absolute Accuracy - maximum, total measurement error, U_{in} - Input voltage - measured voltage, P_r - % of reading - relative error, referred to the present, measured value (from producers specification), O - Offset - constant displacement of all measurement results, D - Drift - displacement of characteristic connected with variation of temperature. If the temperature falls within +15° to +35°C drift is taken into offset, N (Noise) + Q (Quantization) - component based on noise, relates to the number of averages of each measurement.

In producer's specification there are given two values of this component: for a single measurement and for 100 averages.

Measurement accuracy of acquisition card type NI 6052E was estimated up to the formula (3) as follows:

Coefficient "% of reading" from producer's specification is 0,0371% (for measuring range + 10V taking 1 year after calibration, for measured value 10 V).

It gives the value of the first component of formula (3):

- $U_{in} * P_r = 10 * 0,000371 = 3,71 \text{ mV}$

On the basis of the first current measurements it was decided, that the current analysis would be made for 10 averages. It requires the re-counting of the coefficient from the specification according to formula:

$$N+Q \text{ (for } x \text{ averaged points)} = \text{Averaged } N+Q \text{ (from table)} * \sqrt{100/x} \quad (4)$$

In this case:

- $N+Q \text{ (for 10 averaged points)} = 87 \text{ mV} * \sqrt{100/10} = 275 \text{ mV}$

Offset (from producer's specification) is 947 mV. Due to comparative character of the planned measurements the offset can be neglected.

Assume that the temperature during measurements is in the range +15°C to +35°C drift has been already taken into account in the offset so it can also be neglected.

In total the maximum positive error of measurement in these conditions is:

- $A_a \text{ (at full scale)} = \pm (3,71 \text{ mV} + 275 \text{ mV}) \approx \pm 4 \text{ mV}$

The assumed range of measured components value from (-85) to (-60) dB in the linear scale indicates the magnitude 0,5 to 10 mV.

These are small values in comparison with the absolute measurement error. For reduction of the relative measurement error, the input voltage must be increased.

Because of the existence of the outstanding fundamental component in the signal, which in this case does not carry useful diagnostic information, to be able to increase the signal, it is necessary to reduce the outstanding component in advance. The filtering followed by the amplification of the signal should be performed on the analogue side of system. The maximum possible value of the gain is restricted by harmonic current components (3, 5 and 7 harmonic), the amplitudes of which are smaller than the first harmonic by about 40 dB.

After filtering the outstanding component and amplification of the rest of signal by 40 dB, the measured signals will be in the interval of: 50 mV to 1 V.

The relative measurement error of these components, according to their value, will be within the interval 8% to 0,4%.

On the basis of the opening tests there was put into practice an improved system for current tests and motor voltage [8]. This is shown in fig. 1.

Motor current measurement system using tuned frequency filters has four analogue lines. Three for current measurement signals (8 A DC/AC) and one for voltage measurement signal (400 V DC/AC).

It enables the motor current measurements to be made in three phases, and voltage measurement in one supply net phase. In each measuring line there are antialiasing filters with the possibility of choice cutting-off frequency in the given range: 200 Hz, 1 kHz, 10 kHz, 20 kHz. Each filter is of low-pass Butterworth's type.

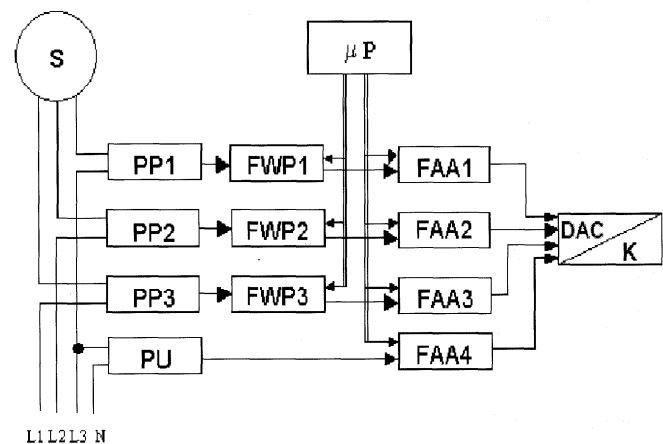

Fig. 1. The diagram of supplying current measurement system for induction motor; M - induction motor, μP - microprocessor, PP1-PP3 - transducers for current measurements, PU - transducer for voltage measurements, FAA1-FAA4 - antialiasing filters, FWP1-FWP4 - narrow band filters, DAQ - data acquisition card, C - computer

Rys. 1. Schemat blokowy system do pomiaru prądu zasilającego silnik indukcyjny; M - silnik indukcyjny, μP - mikroprocesor, PP1-PP3 - przetworniki do pomiaru prądu, PU - przetwornik do pomiaru napięcia, FAA1-FAA4 - filtry antyaliasingowe, FWP1-FWP4 - filtry wąskopasmowe, DAQ - karta akwizycji danych, C - komputer

The current measurement lines contain notch-type filters with automatically tuned cut-off frequency to about 50 Hz (network frequency of motor supplying).

The notch filter is based on integrated universal continuous time filter UAF42 of Burr-Brown's production. Its topology is compatible with Butterworth's second order filter. Converters C/A AD7533 of 10 bits were used for numerical controlling of the cut-off frequency.

The program applied in the microprocessor performed adjustment of filter frequency according to actual networking frequency. The measurements and adjustments are realized separately in each current phase. This enables the adjustments to be independent of the tolerance of components used for setting the filter frequency.

In each line there are amplifiers, which can increase the signal by 40 dB.

Next the signal is transferred to the measuring card placed in the computer of PC class.

The panel of virtual instrument for current investigations is presented in fig. 2.

Then, the system created in LabVIEW environment performs the spectrum analysis. The results of data processed in this way are displayed on the monitor in the form of the current spectrum.

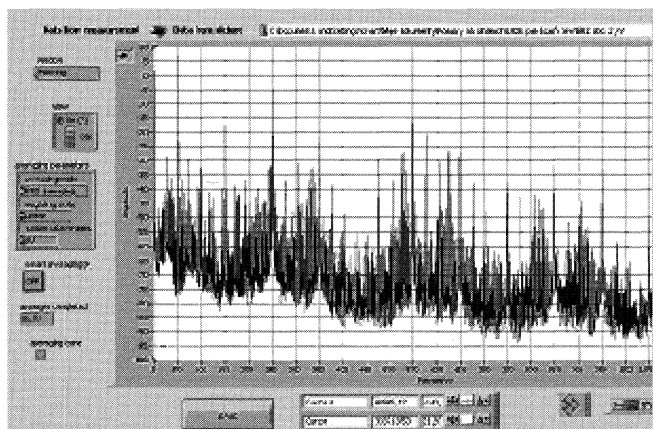

Fig. 2. The panel of virtual instrument for current waveform investigations
Rys. 2. Panel przyrządu wirtualnego do badania krzywej prądu zasilającego silnik

3. Laboratory simulation

The current spectrum of a motor with damaged bearings is very complex and difficult to analyse. In the first stage of experimental tests it has been decided, to facilitate the definition of existing relationships, to force the motor to an oscillation of the air gap at one adjustable frequency. To achieve this, a direct-current motor with variable rotational speed has been attached to the body of the tested, elastically fixed motor. The rotor of the DC motor had a specially-added eccentric mass which during rotation brought the frames of both motors into oscillation with an adjustable frequency.

Fig. 3 presents the spectrum of the tested motor operating with a load of 70% of rated current I_n without external vibration.

In the adequate spectrum for no-load running motor only harmonics numbered from 1th to 18th are visible. In all figures in this section the fundamental component of current is reduced by 30 dB.

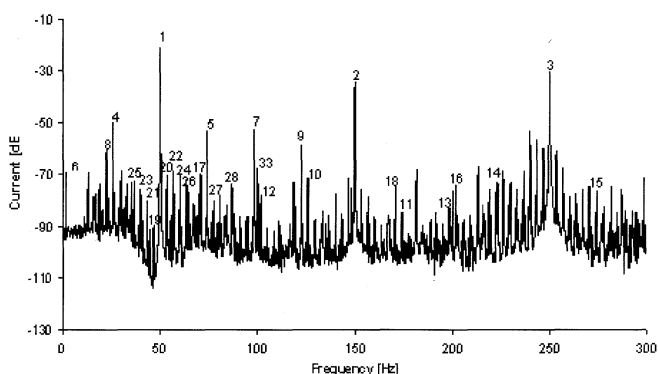

Fig. 3. The current spectrum of an induction motor loaded to 70% of rated current I_n , without external vibrations
Rys. 3. Widmo prądu silnika indukcyjnego z obciążeniem 70% prądu znamionowego I_n bez zewnętrznych wibracji

Fig. 4 presents the spectrum of the motor's supply current waveform for the case of an active vibrator which generates vibrations at 40 Hz. The motor under test is loaded to 70 % of rated current I_n .

Crosses on the spectrum components denote spectral lines which have no diagnostic significance, due to their presence also in case of lack of vibrations. The remaining, new components were identified - these are the effects of modulation of the components from fig. 3 with a vibration frequency of $\pm f_w$ and also $\pm 2f_w$.

As a result, based on the investigations shown in fig. 3 and 4 the mathematical model of the motor current waveform was identified. In this model there are given by author 35 formulas defining the physical source of harmonics, existing in the current spectrum of motor with faultless bearings. There is also 140 formulas, defining the physical source of new harmonics, existing in the current spectrum of motor with faulty bearing. Table 1 presents a few of formulas

for correct bearings, when table 2 presents examples of formulas of expected diagnostic components for faulty bearing.

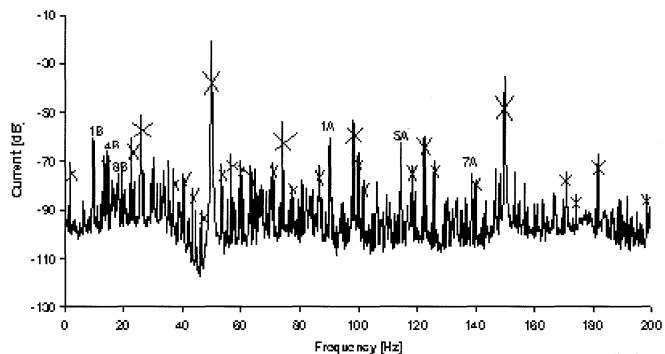

Fig. 4. The current spectrum of an induction motor for a load of 70 % of I_n with an active vibrator generating vibrations of the body of the tested motor at 40 Hz
Rys. 4. Widmo prądu silnika indukcyjnego z obciążeniem 70% prądu znamionowego I_n z aktywnym wibratorem pobudzającym stojan silnika do drgań o częstotliwości 40 Hz

Table 1. Examples of the formulas for spectrum harmonic components for faultless bearing

Tabela 1. Przykładowe zależności określające składowe harmoniczne widma przy nieszkodzonych łożyskach

Symbol in Fig. 3	Formula
1	f_1
2	$3f_1$
3	$5f_1$
4	$f_1 - f_r$
5	$f_1 + f_r$
6	$f_1 - 2f_r$
7	$f_1 + 2f_r$
8	$ f_1 - 3f_r $
9	$f_1 + 3f_r$
10	$3f_1 - f_r$

Table 2. Examples of formulas for diagnostic harmonic components expected for faulty bearing

Tabela 2. Przykładowe zależności określające oczekiwane składowe harmoniczne przy uszkodzonym łożysku

Diagnostic harmonic components expected for faulty bearing (fig.4)	Formula
1A	$f_1 + f_w$
1B	$f_1 - f_w$
1C	$f_1 + 2f_w$
1D	$f_1 - 2f_w$
2A	$3f_1 + f_w$
2B	$3f_1 - f_w$
2C	$3f_1 + 2f_w$
2D	$3f_1 - 2f_w$
3A	$5f_1 + f_w$
3B	$5f_1 - f_w$

4. Investigation results

In fig. 5 is presented an example of motor current spectrum. The bearings in this motor were faultless.

Fig. 6 shows an example of motor current spectrum with real faulty bearing - the outer ring was intentionally broken.

Fig. 7 presents comparison of amplitudes of spectra from fig. 5 and 6 for frequencies chosen according results obtained from model tests.

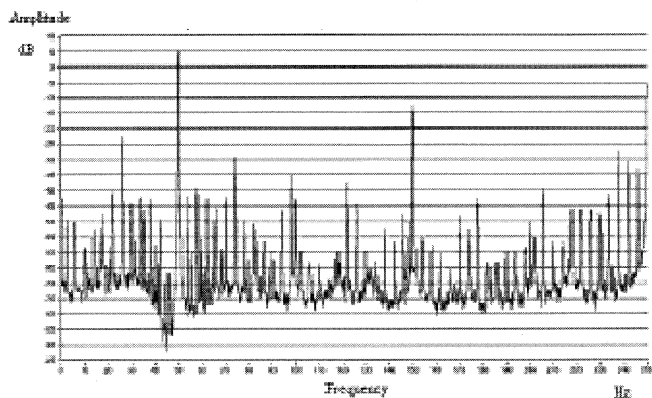

Fig. 5. The current spectrum for faultless bearings
Rys. 5. Widmo prądu dla łożysk bez uszkodzeń

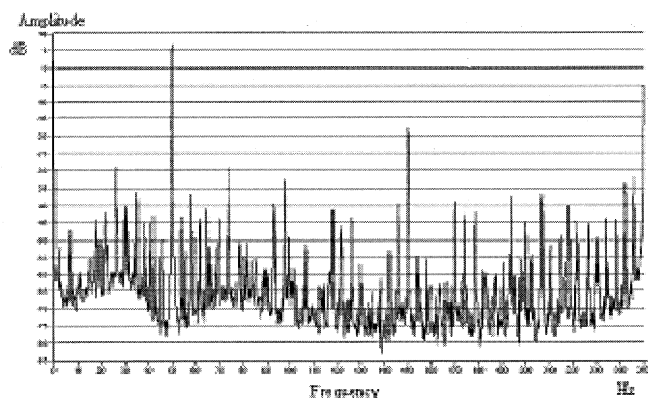

Fig. 6. The supplying motor current spectrum for damaged bearing
Rys. 6. Widmo prądu zasilającego silnik dla uszkodzonego łożyska

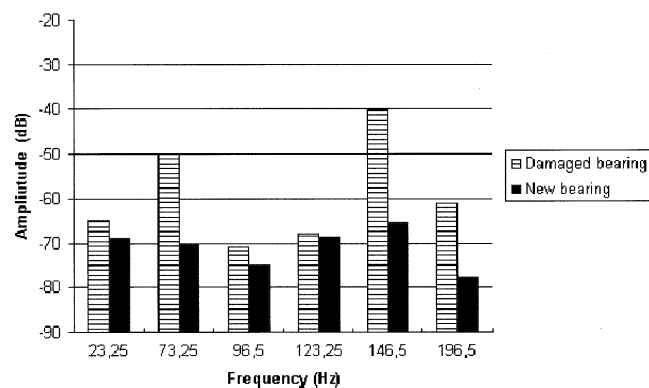

Fig. 7. Comparison of spectra amplitudes (frequencies are chosen according results obtained from model tests)

Rys. 7. Porównanie amplitud w widmie (częstotliwości zostały określone na podstawie badań modelowych)

5. Conclusions

The following conclusions can be drawn from investigations, presented in the paper:

- using notch filter (which reduced the fundamental network harmonic of the supplying current) enable to reveal small components of the spectrum. Measuring these components makes it possible to give diagnostics of the induction motors by current analysis,
- diagnostics of bearings, based on the analysis of the current spectrum becomes easier when the motor runs no-load - the spectrum contains more diagnostic components with greater amplitudes. This situation is contrary to that in diagnostics of squirrel-cages unsymmetry based on an analysis of current,
- due to the fact that generally the current spectrum contains a number of components with closely spaced frequencies, it is necessary

to determine the frequency of the supply network as well as the rotational frequency with an inaccuracy not exceeding the value of ± 0.03 Hz. It is also necessary to have a spectrum resolution of at least 1/8 Hz,

The measurement of the angular velocity and of the supply network frequency should be carried out and averaged over the same time interval in which the current signal sample has been taken for spectrum analysis.

In the proposed measurement system this requirement has been met in such a way that the value of the angular speed and of the supply frequency is calculated on the basis of appropriate components in the same current spectrum that is further used in the searching of diagnostic components,

- success requires that the measurement system has an accordingly low noise level and high dynamic range of measurement,
- the assumption of author's general thesis that all frequency components present in the spectrum of a motor with eccentric rotor can be modulated by the $\pm f_w$ and $\pm 2f_w$ frequency where f_w is the frequency of oscillation of the air gap, permits to reduce the diagnostics to search for spectrum components with frequencies determined beforehand. The f_w frequencies for various types of bearing faults are given in [1],
- the proposed methodology allows to attempt the diagnosis of bearings also in the case when the motor is supplied from a frequency converter. In such a case, components in the supply voltage spectrum should be identified and the diagnostic components calculated. Then components with frequencies modulated according to the principle given above should be searched for. Such tests were carried out on the simulation stand with a vibrator mounted on the motor giving positive results.

References

- [1] R. Schoen, T. Habetler, F. Karman, R. Bartheld: Motor Bearing Damage Detection Using Stator Current Monitoring. IEEE Transactions on Industry Applications, vol.31 No.11/12 1995.
- [2] J. Rusek: Reflection of eccentricities in spectral composition of currents of induction machines, Conference Proceedings of ICEM'96 Conference, Vigo, Spain, 1996.
- [3] J. Rusek: Computer implementation of the induction machine dynamical model accounting for broken bars, eccentricities, slotting and parallel branches. Conference Proceedings of ICEM'96 Conference, Espoo, Finland, 2000.
- [4] J. Rusek, L. Śwędrowski: Wpływ uszkodzenia łożyska na spektrum prądu silnika indukcyjnego. W: Materiały [CD-ROM]. XXXIX Międzynarodowe Sympozjum Maszyn Elektrycznych SME 2003, 9-11 Czerwiec 2003, Gdańsk-Jurata. P.Gdańska 2003
- [5] D. Świsulski D: Measuring systems laboratory. Wydawnictwo PG, Gdańsk 1998.
- [6] National Instruments.: "Programming for Instrumentation", Ed. Nat. Instr. Corp., Austin (USA), 1994.
- [7] L. Śwędrowski, R. Roskosz: Virtual Instruments for Diagnostic Purposes, IMEKO 2000 - XVI World Congress, Vienna Sept.25-28, 2000.
- [8] L. Śwędrowski: Diagnostic measurement of current supplying an electric motor. W: [CD-ROM] Proceedings XVII IMEKO World Congress -Metrology in the 3rd Millenium. June. 22-27, 2003 Dubrovnik, Croatia. 2003 Topic 10-Technical diagnostics.

Tytuł: Pomiar i analiza krzywej prądu zasilającego silnik dla celów diagnostycznych